



Profiler Operator's Manual

- **MP-3000A**
- **MP-2500A**
- **MP-1500A**
- **MP-183A**



Radiometrics Corporation

4909 Nautilus Court North, Suite 110

Boulder, CO 80301 USA

1+303 449-9192 (tel)

1+303 786-9343 (fax)

<http://radiometrics.com>

Table of Contents

1	General Description	1
1.1	Introduction	1
1.2	Instrument Specification	6
1.3	Radiometer Theory of Operation	7
1.4	Brightness Temperature Transfer Function	9
1.5	Profile Retrievals from Observations	10
1.6	Radiometer Error Sources	11
2	Profiler Hardware Description	12
2.1	System Architecture	12
2.2	Functional Description of Components	13
2.3	Detailed Description of Microwave Receivers	15
3	Installation	17
3.1	Site Selection	18
3.2	Site Preparation	19
3.3	Assembly and Setup	19
3.4	Leveling the Tripod	20
3.5	Securing the Tripod	20
3.6	Mounting the Profiling Radiometer	21
3.7	Attaching the Power Cable	22
3.8	Attaching the Data Cable	22
3.9	Securing the Cables	23
3.10	Installing the Control Computer	24
4	Initial Operation and Test of the Instrument	25
5	Radiometer Calibration	32
5.1	LN2 Calibration	33
5.1.1	Contributions to Cold Target Temperature	34
5.1.2	LN2 Calibration Precautions	35
5.1.3	LN2 User Calibration Procedure	36
5.1.4	LN2 Calibration Verification Test	38
5.2	TIP Calibrations	41
5.2.1	LN2 vs. TIP Calibrations: Strengths and Weaknesses	41
5.2.2	TIP Calibration Procedure	41
5.3	Surface Met Sensor Calibration	44
5.3.1	Rotronic S3 Temperature and Relative Humidity Sensor	44
5.3.2	Barometric Pressure	45
5.3.3	Rain Sensor	46
5.3.4	Optional Infrared Thermometer	48
6	Configuration, Control, and Data Processing	49
6.1	Modes of Operation	49
6.1.1	Operating in Manual Mode	49
6.1.2	Operating in Scheduled Mode	50

6.2	Input Files.....	53
6.2.1	Configuration File	53
6.2.2	Procedure Files	56
6.2.3	Factory Procedure Files	63
6.2.4	Neural Network Files	63
6.3	Output Files.....	64
6.3.1	Output File Name Conventions	64
6.3.2	Record Number.....	65
6.3.3	Date/Time Conventions.....	65
6.3.4	Record Type Conventions.....	65
6.3.5	<i>Level0</i> File.....	65
6.3.6	<i>Level1</i> File.....	66
6.3.7	<i>Level2</i> File.....	66
6.3.8	<i>TIP</i> Calibration File.....	67
6.3.9	<i>LN2</i> Calibration File.....	68
6.4	Time Synchronization.....	68
6.5	Reprocessing	68
7	<i>Maintenance and Trouble Shooting</i>	69
7.1	Instrument Maintenance.....	69
7.1.1	Radiometer Calibration	69
7.1.2	Antenna Pointing Calibration.....	69
7.1.3	Radome Replacement	70
7.1.4	S3 Temperature and RH Sensor Maintenance	71
7.1.5	SuperBlower Filter Cleaning and Replacement.....	73
7.1.6	Rain sensor Board	73
7.1.7	IRT Window Maintenance	74
7.1.8	Cables.....	75
7.2	Controlling Computer	75
7.2.1	Operating System Updates	75
7.2.2	Operating Code Updates	75
7.2.3	Neural Network and Procedure File Updates	75
7.2.4	Firmware Updates.....	76
7.2.5	Virus Protection and Firewall.....	76
7.2.6	Error Messages.....	76
8	<i>Warranty and Service</i>	77
8.1	European Certification.....	77
8.2	Symbols Legend	78
	<i>Appendix A: TP-2000 Tripod Assembly</i>	79
	<i>Appendix B: Error Messages for A series Radiometers</i>	82

List of Figures

Figure 1	MP-3000A with optional Azimuth Positioner and IRT.....	1
Figure 2	MP-3000A cut-away diagram.....	5
Figure 3	Absorption spectrum of a typical mid-latitude atmosphere for two altitudes and two water vapor densities.....	8
Figure 4	Atmospheric absorption spectra near 60 and 183 GHz.....	9
Figure 5	MP-3000A Block Diagram.....	12
Figure 6	Left: MP-183A with parabolic antenna system. Right: MP-3000A Flat Mirror, Lens and Wire Grid.....	14
Figure 7	K band, V band and 183 GHz Receivers with cover and Baseband Processor removed. Complete V band receiver shown in the lower right.....	16
Figure 8	Tripod and anchor chain with Profiling Radiometer.....	19
Figure 9	Leveling the TP-2000 Tripod.....	20
Figure 10	Securing the Profiling Radiometer with the T bolt.....	21
Figure 11	Front Panel.....	22
Figure 12	Cable service loop for use with Azimuth Positioner.....	23
Figure 13	Standard CF-52 on left; Optional Rugged Mobile Computer on right.....	24
Figure 14	Operating Code display after power-on tests have completed.....	26
Figure 15	Main Menu Screen.....	27
Figure 16	Press 1 for Level1 data (brightness temperature).....	28
Figure 17	Press 2 for Level2 data (profiles and integrated values).....	29
Figure 18	Press T for TIP Calibration Display; K band Noise Diode calibrations.....	30
Figure 19	Example of Level1 brightness temperature time series plotted in Excel.....	31
Figure 20	Example of Channel Calibration Block in Configuration File.....	33
Figure 21	Calibration target and saddle.....	36
Figure 22	LN2 calibration display.....	37
Figure 23	Excel Plot of Tnd values from User LN2 calibration.....	38
Figure 24	Example of B&L Cryogenic Target temperatures for MP-3000A.....	39
Figure 25	Example of B&L ambient target temperature error for MP-3000A.....	40
Figure 26	Example of B&L statistics for MP-3000A.....	40
Figure 27	Example of <i>TIP</i> data plotted as a function of time.....	42
Figure 28	Example of a processed <i>TIP</i> data file displayed in Excel.....	43
Figure 29	SuperBlower with End Cover removed; S3 sensor and filter.....	44
Figure 30	Location of Standard Pressure Sensor on MCM.....	45
Figure 31	Optional PTB101B Pressure Sensor.....	46
Figure 32	Typical Rain Sensor transfer function.....	46
Figure 33	Rain Sensor.....	47
Figure 34	Left: KT-15 IRT Assembly; Right: Top view of Cabinet with IRT Window.....	48
Figure 35	Navigating to Windows Scheduler.....	50
Figure 36	Screen Shots of the Task Scheduling Procedure.....	52
Figure 37	Configuration File for V5.0 Operating Code (mp.cfg).....	54
Figure 38	Theoretical Thermal Noise for Radiometers.....	62
Figure 39	<i>Level0</i> Record Types.....	66
Figure 40	<i>Level1</i> Record Types.....	66
Figure 41	<i>Level2</i> Record Types.....	67

Figure 42	TIP Calibration Record Types	67
Figure 43	LN2 Calibration Record Types	68
Figure 44	Radome replacement	70
Figure 45	SuperBlower End Cover removal	71
Figure 46	S3 screen removal and cleaning	72
Figure 47	S3 sensor removal	72
Figure 48	SuperBlower filter removal and cleaning	73
Figure 49	Close-up view of Rain Sensor board	74
Figure 50	GPS Receiver on the left; IRT window on the right	74
Figure 51	Radiometrics TP-2000 Tripod Parts	79
Figure 52	Tripod Assembly Components	81
Figure 53	Tripod Fully Assembled	81

List of Tables

Table 1	Instrument Specifications	7
Table 2	Antenna Performance	14
Table 3	Typical contributions to Cryogenic Target Black Body temperature	34
Table 4	Antenna Coordinate System	56
Table 5	Housekeeping Data Parameters logged by “eng command”	59

CAUTION

The radiometer cabinet cover is closely fit to seal against intrusion of insects, spiders, wind blown dust, sand, water and ice. Caution should be used if it is necessary to remove the cabinet cover. After unbuckling the latches on both sides of the cabinet, the cover should be evenly and gently lifted by using the handles on the cabinet cover. Forcing the cover unevenly can result in damage to the radiometer and voiding of the Warranty.

Substitution of another computer for the Control Computer supplied by Radiometrics, or changing the factory software load and settings, automatically voids our Warranty Support Obligation. Should such changes result in need for RDX remote support, these services are to be paid for at our normal hourly support rates.

Important Notice about this Manual

- If the optional VizMet-B software package (described below) *has been installed*, refer to this Operator's Manual for general information about the Profiling Radiometer, and the separate document, *VizMet-B User Guide*, for specific information about the operation of the Profiling Radiometer using VizMet-B.
- If the VizMet-B software package *has not been installed*, the single user Graphical User Interface (GUI) described in this Operator's Manual must be used to Configure, Control, Calibrate and Monitor the operation of the Profiling Radiometer.

Optional VizMet-B Software Package

All Profiling Radiometers are now available with Radiometrics' VizMet-B software package. VizMet-B turns the instrument Control Computer into a powerful web server, providing interactive access to the instrument from any remote computer connected by LAN or the Internet.¹ With the optional VizMet-B software installed on the Control Computer, authorized users can log in and *Configure, Control, Calibrate and Monitor* all aspects of the instrument operation, from anywhere, without installing any special software on the remote computer. The VizMet-B color GUI simplifies and automates the Configuration, Control, and Calibration of the instrument. The 2D and 3D color graphics provide a running 72-hour "quick look history" of the level1 and level2 data products.

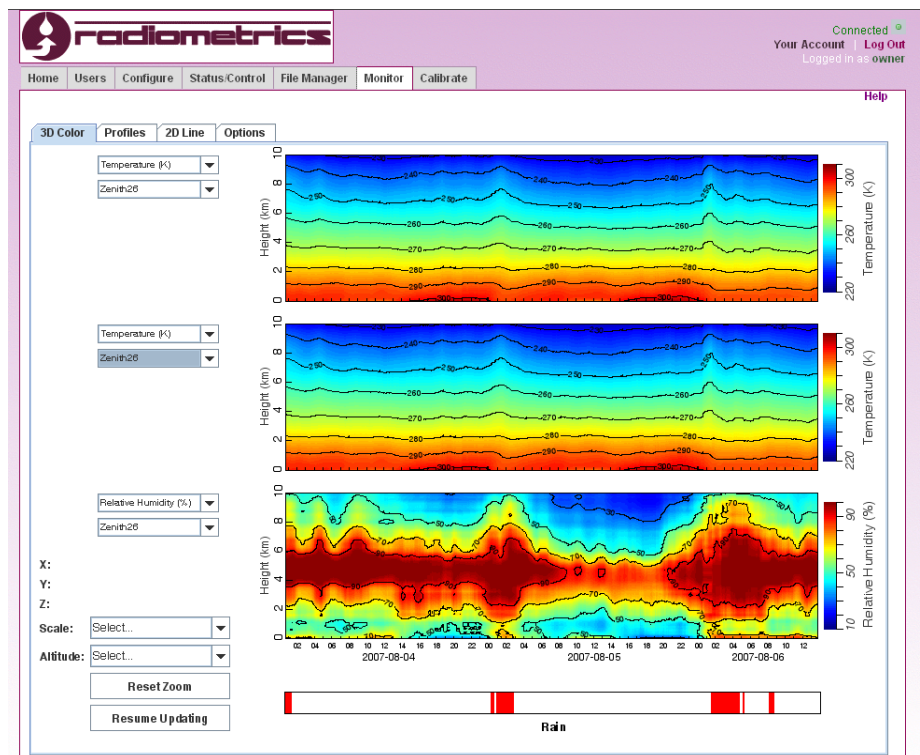

¹ The VizMet-B software package uses Java technology to enable any modern Windows, Mac, Unix, or Linux computer to connect and display the GUI. Remote computers only require a browser (IE or Firefox) and Java.

1 General Description

1.1 Introduction

This manual provides information about the operation of Radiometrics' family of advanced portable profiling microwave radiometers. Information on the following models is included:

- **MP-3000A** 35 channel Temperature, Water Vapor & Liquid Water Profiler
- **MP-2500A** 14 channel 51-59 GHz Temperature Profiler
- **MP-1500A** 21 channel 22-30 GHz Water Vapor Profiler
- **MP-183A** 15 channel 170-183 GHz high sensitivity Water Vapor Profiler

All models share the same basic hardware platform and use the same software. Operation of the four models is the same except as noted in this manual. Throughout this manual, the term "Profiling Radiometer" is used to refer to all models of the Radiometrics family of *advanced* portable profiling radiometers, known as the "A Series".²

Radiometrics Profiling Radiometers produce vertical profiles from the surface to 10 km. The MP-3000A produces high-resolution temperature, relative humidity and water vapor profiles, and low-resolution liquid profiles. The MP-2500A produces temperature profiles only, and the MP-1500A produces water vapor profiles only. The high sensitivity model MP-183A produces accurate water vapor profiles even in arid environments, and useful estimates of the temperature, relative humidity and liquid profiles.



Figure 1 MP-3000A with optional Azimuth Positioner and IRT.

² The A Series replaces the 1st generation family of profilers: Models **TP/WVP-3000**, **TP-2500** and **WVP-1500**

The MP-3000A incorporates two radio frequency (RF) subsystems in the same cabinet. These RF subsystems share the same antenna and antenna pointing system. The temperature profiling subsystem utilizes sky brightness temperature observations at selected frequencies between 51 and 59 GHz. The water vapor profiling subsystem utilizes sky brightness temperature observations at selected frequencies between 22 and 30 GHz. The MP-2500A uses the 51-59 GHz subsystem only, and the MP-1500A uses the 22-30 GHz subsystem only.

The MP-183A was added to the A Series family in 2006. It uses a new frequency agile receiver architecture capable of single-sided observations from 170 GHz up to and including the water vapor line center at 183.31 GHz. The MP-183A is supplied with 15 calibrated channels. It uses a parabolic antenna providing a 1 degree half-power beamwidth.

Surface meteorological sensors (Met Sensors) are included on all models to measure air temperature, relative humidity and barometric pressure. A rain sensor is also standard on all models. An internally mounted, zenith-pointed infrared thermometer (IRT) is optional on all models, and strongly recommended for the MP-3000A to improve the measurement of water vapor and cloud liquid water density profiles.

All Profiling Radiometers have been designed for ease of use, accuracy, reliability, portability, and low power requirements. They only use “passive technology”, thus they do not emit radiation detectable by any normal means. The MP-3000A is shown in Figure 1 with the optional Azimuth Positioner mounted on the Radiometrics model TP-2000 Telescoping Tripod.

Profiling Radiometers are installed outdoors, normally on the TP-2000 Tripod. However, the user may supply an alternative compatible mounting platform. The instrument must be located where primary power is available (normally 115VAC or 230VAC), and the antenna system must have a clear view of the sky, from horizon to horizon, in at least one vertical plane. If the optional Azimuth Positioner is installed, a clear view of the sky is required for all azimuth and elevation angles of interest. Detailed installation requirements are provided in Section 3, Installation.

All Profiling Radiometers are controlled by Radiometrics proprietary software, referred to herein as the “Operating Code”.³ The Operating Code is supplied pre-installed on a dedicated laptop or mobile computer⁴, referred to herein as the “Control Computer”. The Control Computer may be connected directly to the Profiling Radiometer via the supplied RS422 cable, or it may be connected to the Control Computer via the local area network (LAN) using a remote RS422 serial port server.⁵ The Operating Code provides a *single user* Graphical User Interface (GUI) that allows the selection of user-defined observation procedures and automated calibration procedures. Real-time observations and calibration

³ The current operating code is Version V4.32. Future operating code releases may have additional features, or features slightly different from those described here.

⁴ A Panasonic CF-52 Toughbook (or equivalent) laptop is supplied for most installations. A hardened industrial “mobile computer” is supplied for extreme, harsh environments and other special conditions.

⁵ For information on compatible serial port servers, contact Radiometrics Customer Service.

data are displayed in graphical format. Data is stored on the computer in a folder that can be configured to be accessible over the LAN.

New Optional VizMet-B Software Package

All Profiling Radiometers are now available with Radiometrics' VizMet-B software package. VizMet-B turns the Control Computer into a powerful web server, providing interactive access to the instrument from any remote computer connected by LAN or the Internet.⁶ With the optional VizMet-B software installed on the Control Computer, authorized users can log in and *Configure, Control, Calibrate and Monitor* all aspects of the instrument operation, from anywhere, without installing any special software on the remote computer. The VizMet-B color GUI simplifies and automates the Configuration, Control, and Calibration of the instrument. The 2D and 3D color graphics provide a running 72 hour "quick look history" of the level1 and level2 data products.

Use of this Manual:

- If the VizMet-B software package *has been installed*, refer to the separate document, *VizMet-B User Guide*, for information about the operation of the Profiling Radiometer using the VizMet-B GUI.
- If the VizMet-B software package *has not been installed*, the single user GUI described in this manual must be used to Configure, Control, Calibrate and Monitor the operation of the Profiling Radiometer.

The single user GUI can be used in two modes as described in detail Section 6.1:

- Manual Mode
- Scheduled Mode

When the Operating Code is first started in Manual Mode, it performs an automated power-on self-test, and then presents a menu of options. The user may choose to begin automatic operations immediately using: (1) one of several factory-supplied "Procedure Files", (2) a previously saved user-defined Procedure File, or (3) an automated liquid nitrogen (LN2) calibration may be selected.⁷ Procedure Files contain a list of high-level commands that can be scheduled to execute at specific *absolute* times, or executed sequentially without any delay between commands (*relative* times).

Once an option is selected from the menu, the Operating Code begins logging data to *level0* files (raw sensor data in volts), *level1* files (brightness temperatures), *level2* files (profile retrievals), and *TIP*⁸ calibration data files. Real-time graphics of the *level1* and

⁶ The VizMet-B software package uses Java technology to enable any modern Windows, Mac, Unix, or Linux computer to connect and display the GUI. Remote computers require only a browser (IE or Firefox) and Java.

⁷ As discussed in detail in later sections, liquid nitrogen is used seasonally with an external calibration target to calibrate the internal *Noise Diodes* used operationally for continuous system gain measurements.

level2 products, related to the specific option selected, can be displayed. Real-time graphics for the MP-3000A include:

- Met Sensor time series (*level1* data)
- Brightness Temperature time series (*level1* data)
- Temperature, Water Vapor, Liquid Water, and Relative Humidity (RH) Profiles and column integrated vapor and liquid (*level2* data)
- TIP calibration derived values of Noise Diode Temperatures (Tnd_TIP)
- LN2 calibration derived values of Noise Diode Temperatures (Tnd_LN2)

The Operating Code can also be programmed to run automatically under the Windows Operating System Task Scheduler (“Scheduler”). Typically, Procedure Files used with the Scheduler contain all the commands required for a 24 hour observing period, and the Scheduler is used to schedule automated re-launch of the Operating Code every day at 00:00 GMT using a specified Procedure File. Scheduled this way, the Profiling Radiometer Operating Code will produce continuous 24-hour data sets indefinitely, without user intervention.

The Operating Code translates the high-level commands contained in the selected Procedure File into a series of detailed commands that are sent to the Profiling Radiometer.

The primary available Procedure File commands are:

- **trcvcal** Calibrates the Receiver Temperature (Trcv) for specified channels
- **cal21** Calibrates Noise Diode Temperature (Tnd) on 21 K band channels
- **obs** Performs Sky Brightness Temperature (Tsky) observations on specified channels at specified pointing angles and integration time
- **met** Logs Surface Met observations (Tamb, RH, Pressure, Tirt, and Rain).
- **eng** Logs 48 housekeeping data values (engineering data)
- **tdp** Logs the GPS derived Time, Date and Position
- **mac** executes a series of specified procedure commands as a single command
- **nnret** Executes a neural network retrieval using the most recent observations
- **repeat** Provides the means to “loop” the complete procedure a number of times.

For all except **nnret** and **repeat**, the Profiling Radiometer performs the requested command and responds to the Control Computer with a message containing the data or status requested. The Operating Code then processes and logs the data to *tip*, *level0*, *level1* and *level2* files as described in Section 6. **nnret** and **repeat** commands are executed on the Control Computer without any communication with the Profiling Radiometer.

⁸ The term “TIP” is used herein to refer to the TIP calibration method widely described in the literature, wherein the radiometer antenna is tipped to several elevation angles to calibrate the radiometer gain standards (Noise Diodes).

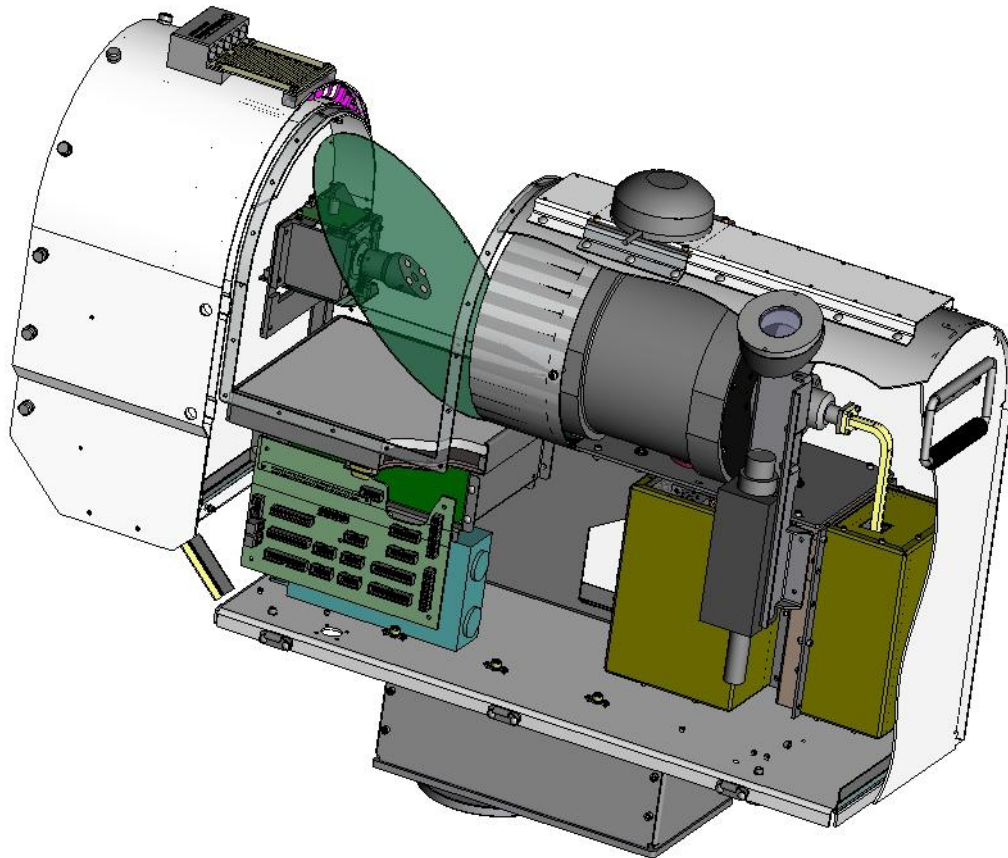

Figure 2 MP-3000A cut-away diagram.

A cut-away diagram of the Profiling Radiometer is shown in Figure 2. Liquid water on the antenna radome (also referred to as the “microwave window”) can cause error in the observed brightness temperature. To minimize such error, the Profiling Radiometer radome is made hydrophobic to repel liquid water, and a special blower system (the SuperBlower) is used to sweep water beads and snow away from the radome. The ambient temperature and relative humidity sensors are integrated in the inlet of the blower system to ensure a steady flow of ambient air over the sensors. A rain sensor is mounted on the top of the blower system. The ambient barometric pressure sensor is located inside the cabinet to minimize the range of sensor ambient temperature. The optional IRT views the sky via a user replaceable low-loss window in the cabinet.

1.2 Instrument Specification

Function or Parameter	Specification
Calibrated Brightness Temperature Accuracy ⁹	$0.2 + 0.002 * T_{kBB} - T_{sky} $ ¹⁰
Long Term Stability	<1.0 K / yr typical
Resolution (depends on integration time) ¹¹	0.1 to 1 K
Brightness Temperature Range ¹²	0-400 K
Antenna System Optical Resolution and Side Lobes	
22-30 GHz	4.9 - 6.3° -24 dB
51-59 GHz	2.4 - 2.5° -27 dB
170-184 GHz	1.0° - 1.1° -40 dB
Integration Time (user selectable in 10 msec increments)	0.01 to 2.5 seconds
Frequency Agile Tuning Range (Accuracy = $\pm 3 * 10^{-6}$)	
Low Water Vapor Band (MP-1500A & MP-3000A)	22.0 – 30.0 GHz (K band)
Oxygen Band (MP-2500A & MP-3000A)	51.0 – 59.0 GHz (V band)
High Water Vapor Band (MP-183A)	170.0 – 183.6 GHz
Minimum Frequency step size (K, V and 183)	2.0, 4.0 or 12 MHz
Standard calibrated channels	
MP-3000A	35
MP-2500A	14
MP-1500A	21
MP-183A	15
Pre-detection channel bandwidth (effective double-sided RF bandwidth)	300 MHz (except MP183A = 1 GHz)
Surface Sensor Accuracy	
Temperature (-50° to +50° C)	0.5° C @ 25° C
Relative Humidity (0-100%)	2 %
Barometric pressure (800 to 1060 mb) ¹³	0.3 mb
IRT ¹⁴ (Note: $\Delta T = T_{ambient} - T_{cloud}$)	$(0.5 + .007 * \Delta T)^\circ, C$
Brightness Temperature algorithm for <i>level1</i> products	4 point nonlinear model
Retrieval algorithms for <i>level2</i> products	Neural Networks

⁹ Specified accuracy for instrument calibrated with an external target with no error.

¹⁰ Absolute accuracy is best for sky brightness temperatures close to ambient, such as for the highest V band channels, and degrades as the absolute difference between the black body reference and sky temperatures increases.

¹¹ Typical resolution for 250 msec integration time is 0.25 K.

¹² Wider ranges are available. 0-400K is optimum for meteorological applications.

¹³ With optional wide range pressure sensor, the range is 600-1060 mb. *Required for operation above ~1600m.*

¹⁴ The IRT is optional on all Profilers. The standard Field of View (FOV) = 5°. Other lenses are available.

Function or Parameter	Specification
Calibration Systems Primary standards Operational standards	LN2 and TIP methods Noise Diodes + ambient Black Body Target
Environmental Operating Range Temperature ¹⁵ Relative Humidity Altitude ¹⁶ Wind (operational/survival)	-40° to +35° C 0-100 % -300 to 3000 m 30 m/s / 60 m/s
Physical Properties Size (H X W X L) Mass	50 X 28 X 76 cm 27 kg
Power requirement (100 to 250 VAC / 50 – 60 Hz)	200 watts typical (Tamb = +25C) 400 watts max at “cold start”
Data Interface Primary computer port Auxiliary port Standard cable length ¹⁷	RS422 57600 kb/s 8N1 RS422 1.2 - 57600 kb/s 8N1 30 m
Data File Formats	ASCII CSV (Excel compatible) (comma separated variables)

Table 1 Instrument Specifications.

1.3 Radiometer Theory of Operation

This section describes the theory of operation for the MP-3000A. The theory of operation also applies to the MP-183A, MP-2500A and MP-1500A models, within the bands observed by those instruments.

Ground-based microwave profiling methods make use of atmospheric radiation measurements in the 20 to 200 GHz region. The atmospheric absorption spectrum at several altitudes for a typical mid latitude atmosphere is shown in Figure 3. Two altitudes and two water vapor densities are shown. The features near 22 and 183 GHz are water vapor resonances that are pressure broadened according to the pressure altitude of the

¹⁵ A high operating temperature option is available to extend operational temperature to +55C. Contact Radiometrics for details.

¹⁶ The optional wide range pressure sensor (600-1060 mb) is required for operation above ~1600m.

¹⁷ The 30m length is standard. RS422 communications cable lengths up to 1000 m are available by special order.

water vapor distribution. The feature near 60 GHz is an assemblage of atmospheric oxygen resonances. The cloud liquid water emission spectrum has no resonances in this frequency range, and increases approximately with the second power of frequency in this region.

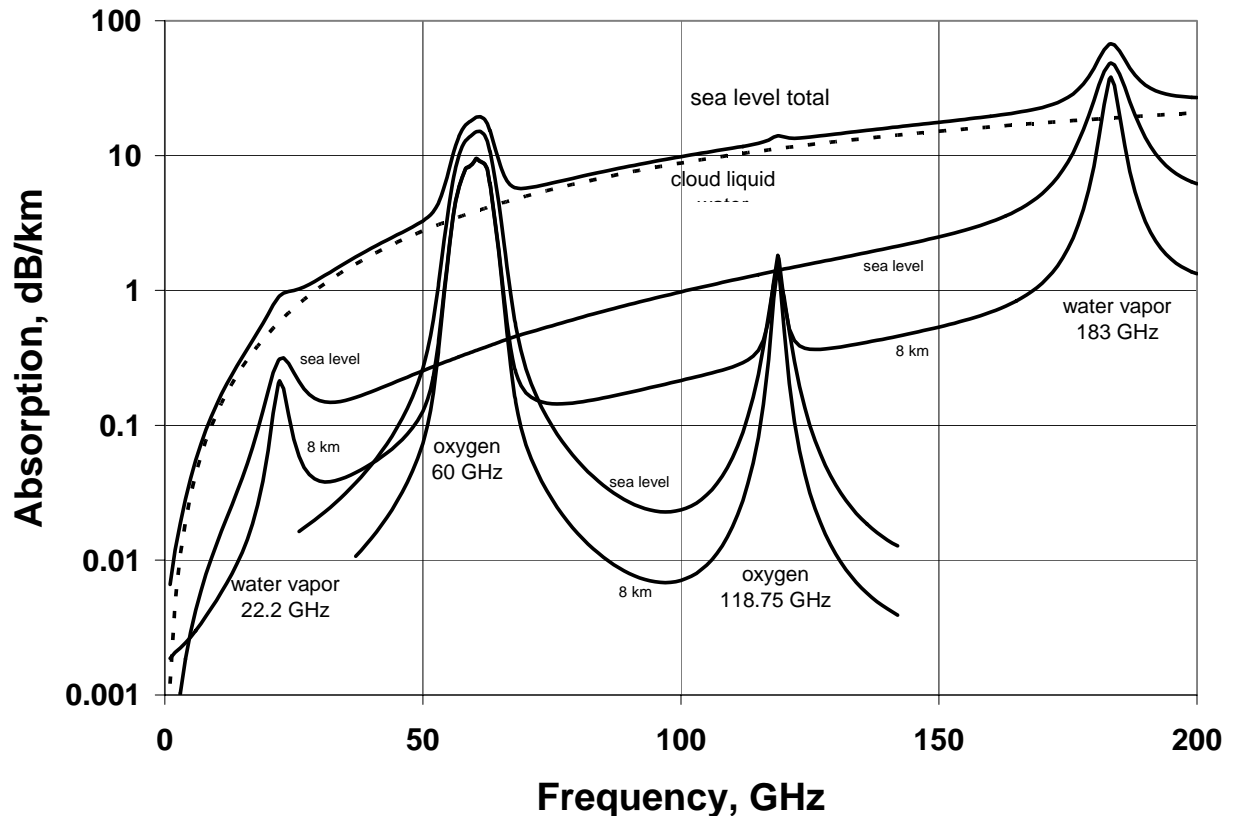

Figure 3 Absorption spectrum of a typical mid-latitude atmosphere for two altitudes and two water vapor densities.

Temperature profiles can be obtained by measuring the radiation intensity, or brightness temperature, at points along the side of the oxygen feature at 60 GHz. By sampling the brightness temperatures outward from line center, where the opacity is so great that all signal originates from the atmosphere close to the antenna, on to the “wing of the line”, where the radiometer “sees” further into the atmosphere, the instrument can obtain altitude information. Emission at any altitude is proportional to local temperature and density of oxygen; thus the temperature profile can be retrieved.

Water vapor profiles can be obtained by observing the intensity and shape of emission from pressure broadened water vapor lines. The line near 22 GHz is suitable for ground based profiling in relatively moist areas. The more sensitive 183 GHz line is well suited for ground-based water vapor profiling in arid environments. The emission from water vapor is in a narrow line at high altitudes and is pressure broadened at low altitudes. The intensity of emission is proportional to vapor density and temperature. Scanning the spectral profile and mathematically inverting the observed data can therefore provide water vapor profiles.

Limited resolution cloud liquid water profiles can be obtained by measuring the contribution of cloud liquid water to atmospheric spectral features of varying opacity. Cloud liquid information in the 22 to 30 GHz and 51 to 59 GHz bands is used by the MP-3000A radiometer to produce a liquid profile. Cloud base altitude information derived from the optional IRT improves the water vapor and liquid water profile retrievals.

The absorption of the atmosphere in the vicinity of the assemblage of oxygen lines centered at 60 GHz at sea level and at 4 km is shown in Figure 4, left. Pressure broadening smears the numerous oxygen lines into one broad feature. Pressure broadening of the water vapor line near 183 GHz at several altitudes is shown in Figure 4, right. The 22 GHz water vapor line exhibits similar pressure broadening.

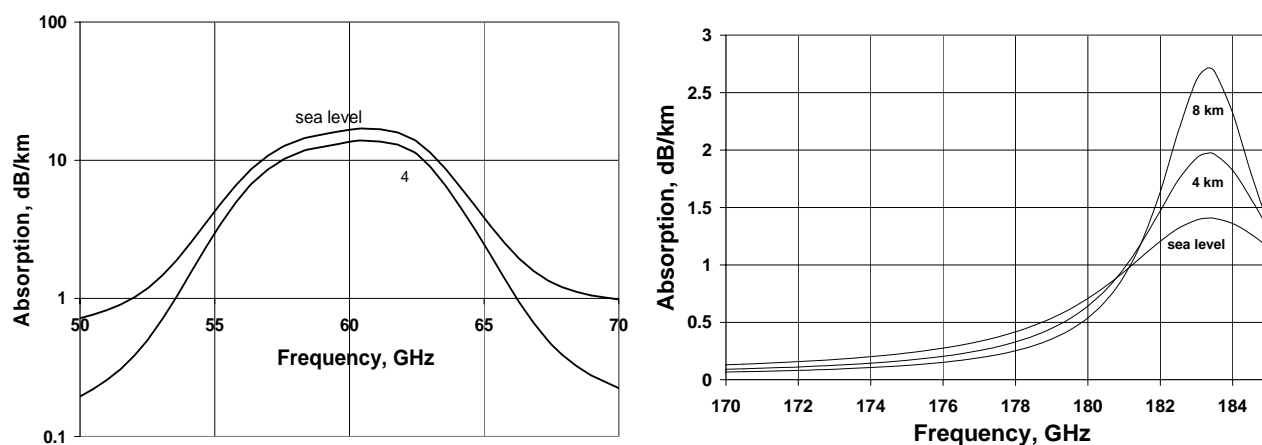

Figure 4 Atmospheric absorption spectra near 60 and 183 GHz.

Surface relative humidity, temperature, and barometric pressure are measured by the Profiling Radiometer and used in the determination of profiles. Additionally, an optional vertically pointed IRT indicates the presence of cloud, and measures cloud base temperature if clouds are present (MP-3000A only). Knowing cloud base temperature yields the vapor density at cloud base (at saturation), and combined with the retrieved temperature profile, yields cloud base altitude. These physical measurements are important constraints for profile retrieval.

1.4 Brightness Temperature Transfer Function

All Profiling Radiometers use a state-of-the-art algorithm and calibration system to derive sky brightness temperature from the *level0* observations (receiver detector output voltage). This algorithm makes use of factory measured calibration coefficients to compensate for the small but finite effects of ambient temperature and system non-linearity. The algorithm and calibration system also include proprietary methods for the elimination of most “1/f” noise in observations, thereby significantly reducing the overall noise compared to competing technologies. The transfer function is as follows:

$$\mathbf{Tsky} = (\mathbf{Vsky/gain_sky})^{(1/\alpha)} - \mathbf{Trcv_sky}$$

Where measured values are:

- Vsky** = integrated receiver output from a sky observation with Noise Diode off
- Vsky_nd** = integrated receiver output from a sky observation with Noise Diode on
- Vbb** = integrated receiver output from an ambient Black Body target observation with Noise Diode off
- Vbb_nd** = integrated receiver output from an ambient Black Body target observation with Noise Diode on
- TkBB** = Black Body target effective radiation temperature¹⁸

Where calibrated parameters are:

- α** = non-linearity correction exponent
- Tnd290** = Noise Diode temperature @ TkBB = 290K
- K1 - K4** = factory calibrated temperature coefficients
- dTdG** = receiver hardware specific parameter

Where calculated values are:

- gain_sky** = gain during sky observation = $[(Vsky_nd^{(1/\alpha)} - Vsky^{(1/\alpha)}) / (Tnd290 + TC)]^{\alpha}$
- Trcv_sky** = Receiver temperature during sky observation = $Trcv_bb + dTdG * (gain_sky - gain_bb)$
- gain_bb** = gain during ambient Black Body Target observation = $[(Vbb_nd^{(1/\alpha)} - Vbb^{(1/\alpha)}) / (Tnd290 + TC)]^{\alpha}$
- Trcv_bb** = Receiver temperature during ambient Black Body Target observation = $(Vbb/gain_bb)^{(1/\alpha)} - TkBB$
- TC** = $K1 + K2 * TkBB + K3 * TkBB^2 + K4 * TkBB^3$

1.5 Profile Retrievals from Observations

Extensive analysis indicates that artificial neural networks outperform other methods for retrieving water vapor, cloud liquid water, and temperature profiles from radiometric data. The Profiling Radiometers therefore use this mathematical inversion method for profile determination. Neural networks supplied by Radiometrics are derived using the *Stuttgart Neural Network Simulator* and a history of radiosonde profiles. A standard back-propagation algorithm is used for training, and a standard feed-forward network is used for profile determination. Profiles are output at 58 height levels, starting with 50 meter steps from the surface up to 500 m, then 100 m steps to 2 km, and 250 m steps from 2 to 10 km. Although the number of independent measurements (eigenvalues) is less than the 58 retrieved layers, the finer “resolution” provides better displays and easier processing in subsequent data processing steps. Above approximately 7 km, the atmospheric water vapor density and temperature approach the climatological mean values.

¹⁸ TkBB is the measured physical temperature of the ambient Black Body target adjusted for implementation bias.

1.6 Radiometer Error Sources

The operator should be aware of the following error sources:

- The Sun is a 6,000 K Black Body radiator. Therefore, K and V band Observations (3-6 degree beamwidth) should be avoided in directions within ~15 degrees of the Sun position, where error up to 60 K can result. The MP-183A, with 1° beamwidth and very low sidelobes, can be pointed closer to the sun without errors, but the instrument will be saturated if pointed to the Sun.
- Neural network retrieval algorithms are somewhat site dependent, especially for retrieval of water vapor and liquid water. The operator should ensure that the retrieval coefficients are representative for the observation site. Such retrieval coefficients are generated from a history of radiosonde (RAOB) data from a representative site.
- Liquid water on the Profiling Radiometer radome can result in artificially high radiometer brightness temperature measurements. However, Radiometrics' patented Rain Effect Mitigation (REM) system, which includes the hydrophobic radome and SuperBlower, minimizes the accumulation of liquid water on the radome and provides measurement capability during most precipitation events.
- Radio frequency interference (RFI) can cause "spikes" in the data. Although Radiometrics has implemented RFI protection throughout the systems, strong transmitters, especially in the 10 to 1000 MHz, 22 to 30 GHz, and 51 to 59 GHz regions can interfere with the Profiling Radiometer receivers. Observations are averaged to minimize this effect. However, spikes with a magnitude greater than several Kelvins can affect the accuracy of the retrieved profiles. The Profiling Radiometer should be installed in a location that is isolated or shielded from strong radio transmitters.¹⁹
- Calibration error will degrade the inherent instrument accuracy. Noise Diodes provide an accurate, high stability operational gain reference, but they are only as accurate as the accuracy of the primary standards used to calibrate them. Care should be taken when calibrating the Noise Diodes using either of the methods described herein. The internal ambient Black Body target provides a means to calibrate the system temperature, from which the receiver temperature (Trcv) is derived. The receiver temperature is very stable, so observations of the Black Body target can be relatively infrequent. To minimize Trcv error during periods of rapidly changing ambient temperature, receiver temperature calibrations should be performed every 5 minutes or more often.
- In all radiometers, the system gain fluctuates with "1/f noise", resulting in added random noise in the observations. For typical integration times (~1 sec), 1/f noise can be dominant. All Profiling Radiometers use Radiometrics' proprietary calibration methods and transfer function to virtually eliminate 1/f noise contributions.

¹⁹ Note that Radiometrics patented frequency agile architecture uniquely provides the means to select RFI-free channels within each band to mitigate RFI problems, should they develop. If the user suspects RFI problems, contact Radiometrics for assistance in programming alternative frequencies.

2 Profiler Hardware Description

2.1 System Architecture

All Profiling Radiometer models share a common modular architecture. The block diagram in Figure 5 provides an overview of the primary system level components in the MP-3000A. All system level components are plug-compatible and factory interchangeable for ease of maintenance and repair. Most are also field replaceable units (FRUs).

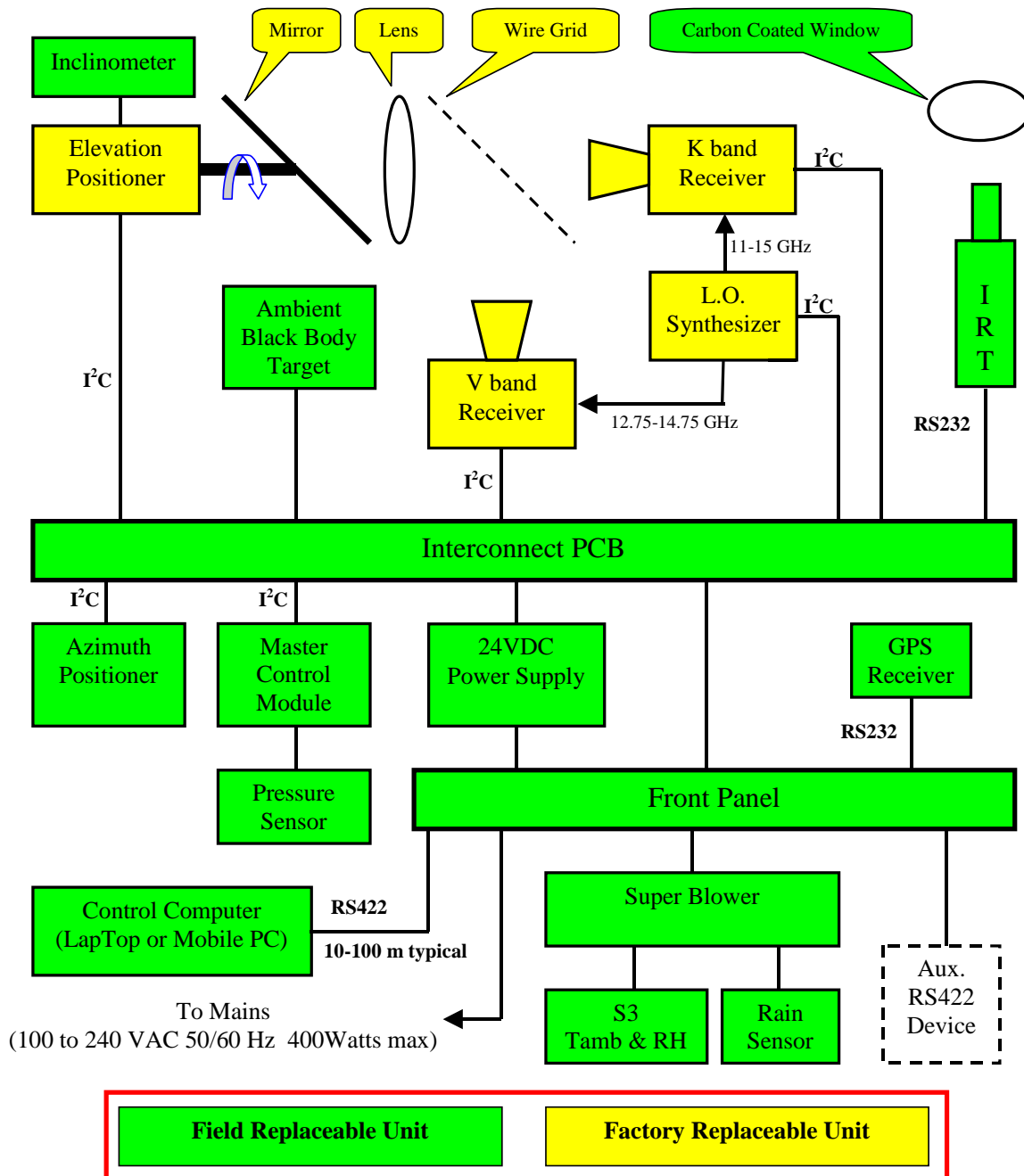

Figure 5 MP-3000A Block Diagram.

The MP-2500A is identical to the MP-3000A except that it does not include the K band receiver. The MP-1500A does not include the Wire Grid or V band receiver. The MP-183A uses a 183 GHz receiver in place of the K and V band receivers. For the MP-183A, a 150 mm parabolic mirror replaces the flat mirror, lens and Wire Grid used on the other models. Note that the Azimuth Positioner and IRT are *optional* components available on all models.

2.2 Functional Description of Components

Primary power enters the instrument via a twist-lock connector on the Front Panel. Primary power is controlled by a toggle switch on the left side. A fuse protects the mains. DC power is supplied to all components from the 24VDC power supply, which is the only component that connects to primary power. A 26 conductor ribbon cable connects all front panel connectors (except primary power) to the Interconnect Printed Circuit Board (PCB). The two RS422 ports on the Front Panel have 2000V optical isolation incorporated on the back side of the Front Panel Assembly. The Interconnect PCB serves as a power and communications distribution hub. All the primary components plug in to the Interconnect PCB.

The SuperBlower supplies high volume air-flow over the radome for Rain Effect Mitigation. A field replaceable Rotronic S3 ambient Temperature and RH sensor is mounted in the air intake of the SuperBlower, thus assuring both minimal solar bias and robust aspiration of the sensor. Digital communication between the S3 sensor and the Master Control Module (MCM) eliminates noise and offset error common to analog sensors. A field replaceable rain sensor is mounted on the top of the SuperBlower.

A field replaceable GPS Receiver is mounted on the top of the cabinet and connected to the Front Panel via RS232 cable. The GPS Receiver supplies Time, Date and Position data to the MCM. The Control Computer uses GPS data to maintain the accuracy of the Windows System Clock, and to place a position stamp in the data files.

The MCM controls all the other components in the radiometer. It consists of a microprocessor, logic circuits, analog circuits, voltage regulators and a miniature temperature controlled compartment with sockets for the standard field replaceable pressure sensor. The MCM is an FRU. The firmware can be upgraded in the field with a laptop, or via Internet if the Control Computer is connected to the Internet. The MCM communicates with the Control Computer via an optically isolated RS422 cable, responding to high-level Control Computer commands with status and data as required.

The Control Computer is a Windows XP Pro computer with Radiometrics Operating Code and ancillary applications preinstalled. Users communicate with the instrument from the Control Computer using the Operating Code user interface. Normally, a factory or user defined Procedure is selected by the user, and executed by the Control Computer to sequence through a series of specified calibrations, sky observations and data processing events. Data is logged to files stored in the Operating Folder on the Control Computer, and accessible via LAN and the Internet (if connected and enabled by the user).

When the Control Computer issues a command to make a set of radiometric observations, the MCM points the antenna to the elevation and azimuth angles required. Then it sets the receiver local oscillator (synthesizer) to the first required frequency and commands the

appropriate receiver to make the first observation. When the receiver completes the observation on the first frequency, the MCM commands the synthesizer to tune to the next required frequency and then commands the appropriate receiver to make the next observation. This sequence is repeated until all channels requested by the Control Computer have been observed. Then the data is sent from the MCM to the Control Computer.

The antenna beam is formed by the 45° Flat Mirror, 150 mm Lens and Wire Grid. The Lens acts as a phase correcting device that focuses plane wave fronts on the phase center of the corrugated feed horns. Special baffles and absorbing collars are included to minimize errors due to side lobes and reflections. The result is higher gain and lower side lobes than can be obtained with a horn alone, while maintaining small size. Due to the superior performance at very high frequencies, the MP183A uses a parabolic mirror. The parabolic mirror eliminates the need for a Lens or Wire Grid. Antenna characteristics are summarized in Table 2.

Antenna Characteristic	22 GHz	30 GHz	51 GHz	59 GHz	170-183 GHz
Full width half power beam width	6.3	4.9	2.5	2.4	1.0
Gain, dBi	30	32	36	37	40
Side lobes, dB	<-23	<-24	<-26	<-27	<40 dB

Table 2 Antenna Performance.

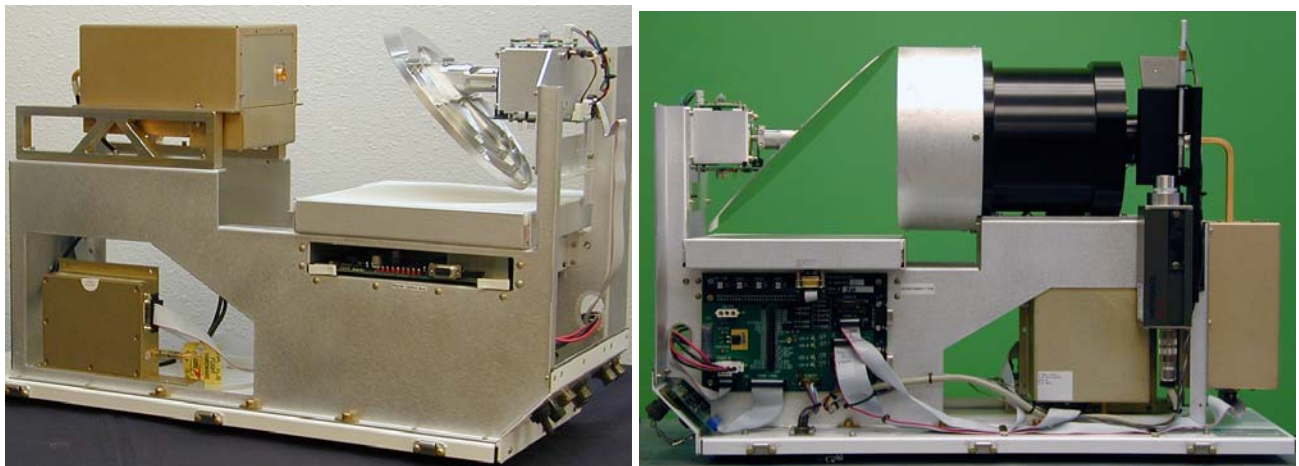

**Figure 6 Left: MP-183A with parabolic antenna system.
Right: MP-3000A Flat Mirror, Lens and Wire Grid.**

Incoming microwave energy passes through the radome (not shown in Figure 5) and is reflected by the Mirror into the Lens, where the energy is focused on the microwave corrugated feed horns associated with each Receiver. The Wire Grid separates incoming microwave energy into two paths, passing the vertically polarized waves straight through

the grid to the K band horn, and reflecting the horizontally polarized waves down to the V band horn.

The Elevation Positioner can rotate the Mirror 360° to point the beam to any elevation angle. When pointed straight down (270°), the antenna points to the internal ambient Black Body Calibration target. When the Control Computer sends a command to the MCM to calibrate the receivers, the MCM commands the Elevation positioner to 270° and collects a set of observations on all channels to be calibrated. The MCM sends the observation data and physical temperature of the ambient Black Body Target to the Control Computer where the receiver temperatures (Trcv) are calculated and logged.

A 2-axis inclinometer is mounted on the top of the Elevation Positioner. This device measures the north-south and east-west instrument tilt angles. This provides the means to correct the elevation angles for any static offset due to instrument leveling error. The Elevation Positioner microprocessor digitizes the analog tilt values and sends them to the MCM.

The optional IRT Assembly (photo on the right) consists of the KT-15 IRT, mounting bracket, IR Black Body target, a low-loss carbon coated window and 2 temperature sensors. The IRT and window are field replaceable. The IRT communicates with the MCM via RS232.

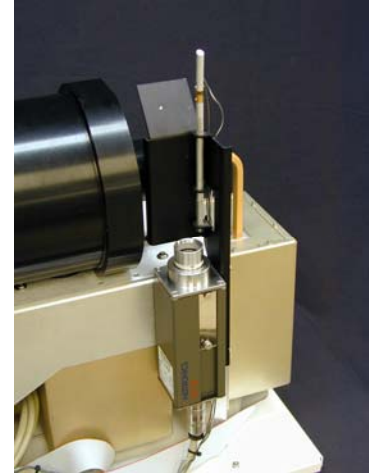

The optional Azimuth Positioner (photo on the right; bottom view) is installed between the instrument and the Tripod to provide full spherical coverage. It is powered and controlled by the instrument via a connector on the bottom of the instrument. With the Azimuth Positioner installed, the antenna can be pointed to any azimuth and elevation angle.

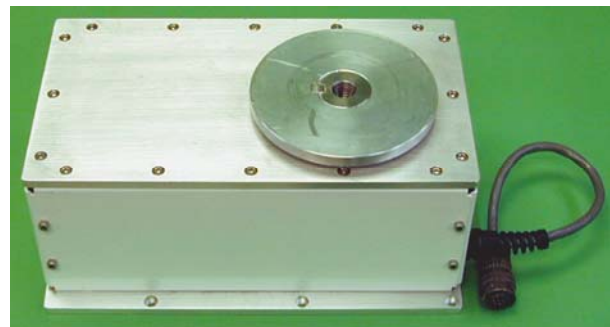

2.3 Detailed Description of Microwave Receivers

The Profiling Radiometers utilize a single heterodyne, direct double sideband down conversion receiver architecture. All receivers are similar in architecture and construction, except for the frequency ranges observed. Microwave channels are selected using a high stability frequency synthesizer with 1 MHz resolution to tune to any available channel in each band. There are 4001 available channels in the 22-30 GHz band, 2001 channels in the 51-59 GHz band, and 1134 channels in the 170-183.6 GHz band. The resulting frequency agility is a patented feature of Radiometrics Profiling Radiometers, making them unique in their ability to scan many channels without the high cost and complexity of filter-bank technology. Standard receivers are supplied with 21 *calibrated channels* in the 22-30 GHz band, 14 calibrated channels in the 51-59 GHz band, and 15 calibrated channels in

the 170-183 GHz band.²⁰ Any of the other available channels can be factory calibrated to meet specific customer requirements.

The ability to tune any in-band frequency also enables these Profiling Radiometers to emulate other microwave profilers for comparative measurements, or to transfer the calibration to other radiometers. For microwave communications link studies, Sky brightness temperatures can be measured at any in-band frequency of interest. Figure 7 contains photographs of the K band, V band and 183 GHz receivers.

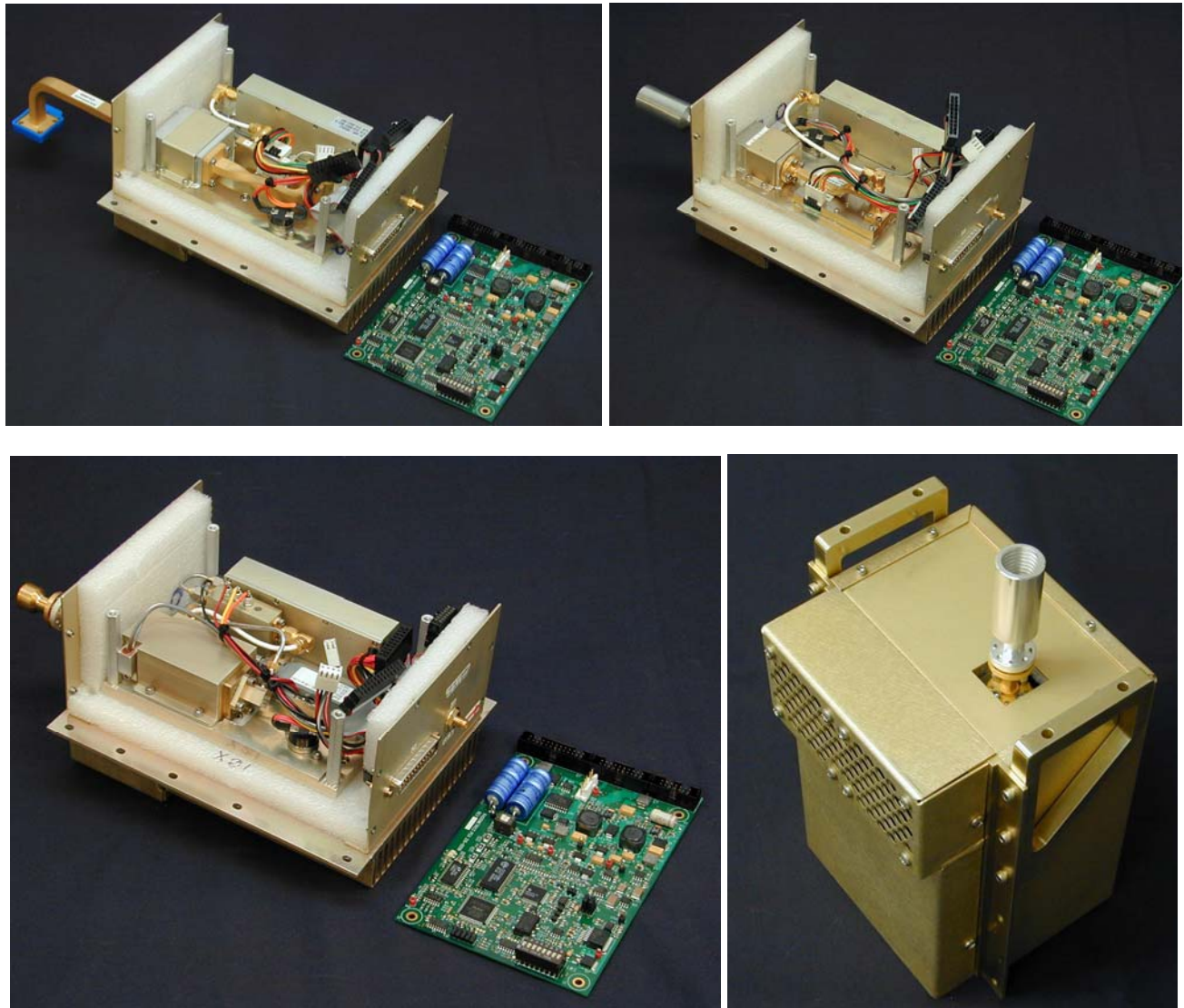

Figure 7 K band, V band and 183 GHz Receivers with cover and Baseband Processor removed. Complete V band receiver shown in the lower right.

The receivers accept input power from the antenna system and downconvert the input spectrum to a common IF frequency band. The IF Module amplifies, filters and detects the signal. The square law detector output voltage is nearly proportional to system temperature

²⁰ The 21 K and 14 V band calibrated channels include the 12 legacy channels used in older Radiometrics models.

(combined antenna and receiver noise). The detector output is amplified within the IF Module to a high level (1-2V typical), low-pass filtered and then digitized by the Baseband Processor (BBP). Receiver frequency selection is accomplished by setting the desired local oscillator frequency in the L.O. Synthesizer. Each Receiver has a noise source (Noise Diode), used for system gain measurement, controlled by the BBP. The physical temperature of the microwave components is stabilized to ~30 mK RMS by Peltier devices controlled by a PID control loop in the BBP.

3 Installation

The Profiling Radiometer includes the following items:

- Profiling Radiometer instrument
- Control Computer with Operating Code²¹
- Power cable
- Communications cable
- Mounting Plate and T-Bolt (secures instrument to mount)
- Operators Manual
- Spares, including misc. hardware, 2 radomes, fuse and SuperBlower inlet filter
- Maintenance Tool Kit
- Reusable Hard Transport Case

In addition, the following Options may be included:

- VizMet-B Webserver Software for remote access and advanced features
- TP-2000 Telescoping Tripod (optional)²²
- KT-15 IRT Assembly (optional)²³
- Cryogenic LN2 Calibration Target (optional)²⁴
- Azimuth Positioner (optional)
- High Altitude Barometer (optional)²⁵
- High operating temperature option (extends operations to +55C)

²¹ Panasonic Toughbook CF-52 standard; rugged outdoor mobile computer, UPS and NEMA4 enclosure available.

²² Recommended for most installations. If the Tripod is not used, customer must provide an equivalent level mount.

²³ Recommended for all MP-3000A instruments. Required for MP-3000A cloud-base determination.

²⁴ Optional for the calibration of the MP-1500A; Required for the calibration of all other models. One target can be used for all instruments at one location.

²⁵ Available on all models; required for barometric pressure below 800 mb.

Before starting the installation, check to verify that all required components are on hand. Notify Radiometrics and the transportation provider if any items are missing. To install the instrument, follow the steps below.

3.1 Site Selection

Select a suitable site for the Profiling Radiometer and the Control Computer. The Profiling Radiometer can be set up on the ground (concrete, asphalt, or other firm surface), or on the roof of a building. When selecting a site, it is important to consider the following factors:

- It is essential to select a site where the antenna field of view will not be obscured or contaminated by earth surface features, such as mountains, trees, buildings, etc. The antenna elevation angle changes during normal operation from near the horizon in one direction to near the horizon in the opposite direction. The antenna “looks out” through the radome, so the elevation angle changes in the plane orthogonal to radome. For best TIP calibration performance, it is desirable to position the antenna down to an elevation angle of 25 degrees in each direction. To prevent earth surface radiation from contaminating the TIP calibration, there should be no surface feature above 5 degrees in elevation angle if within 20 degrees of the elevation steering plane. If the optional Azimuth Positioner is installed, then there should be no surface feature above 5 degrees in elevation angle for all azimuth angles of interest.
- The site must have a solid surface for mounting and securing the tripod. It is not necessary for the surface to be level²⁶, but it must be stable so that the instrument will remain level over time and changing wind load. Under strong wind conditions (>100 km/hr), the side loads are very high, producing high forces on the legs. The best way to ensure the integrity of the system under strong wind conditions is to use both the center pull chain, and bolts in the tripod feet. See Appendix A and Figure 53 for details.
- Access to the instrument will be necessary for maintenance. A site should be chosen that provides security from unauthorized persons, while making access for maintenance convenient.
- The standard power cable is 30 m long. Longer cables can result in low voltage. Therefore, primary power should be available within 30 m. If power is not available within 30 m of the preferred site, a new primary power circuit should be installed rather than using long extension cords.
- The standard RS422 data cable is also 30 m long. If the Control Computer needs to be located more than 30m from the instrument, a cable made to any custom length up to 100m may be ordered. For longer distances, consult the factory for advice. In these cases, it may be better to pull the cable first and add connectors in the field.

²⁶ The instrument is leveled by adjusting the tripod leg-length. Therefore, the tripod can be mounted on a moderately uneven or sloped surface.

- The surface meteorological sensors are high performance devices, but the data can be biased by local sources of air contaminated by roof top exhaust vents, nearby roads, etc. Therefore, the Profiling Radiometer site should be separated a reasonable distance from all local sources of contaminated air.
- The Profiling Radiometer uses one or more sensitive, wideband microwave receivers. To minimize the risk of contamination from radio transmitters, a site should be chosen free of all in-band radio frequency interference greater than -144 dBm/MHz (30 dB below kTB). Out-of-band interference can also result from HF, VHF, UHF or microwave transmitters very near the Profiling Radiometer.
- If the standard Panasonic Toughbook CF-52 is selected for the Control Computer, it should be located in a protected environment with temperature 0-40C. If the rugged mobile computer option is selected, it should be located in a protected environment with temperature -40 to $+60$ C.

3.2 Site Preparation

Once sites have been selected for the Profiling Radiometer and the Control Computer, provisions should be made for the Tripod anchoring technique chosen, and the routing of cables. If the installation will be permanent, the use of conduit pipe(s) for the cables should be considered. Conduit will help protect the cables from rodent damage, moisture and lightning induced transients. A low impedance earth ground should be connected to the Tripod at any convenient attachment point (customer provided equipment).

3.3 Assembly and Setup

The Model TP-2000 telescoping aluminum tripod is typically furnished with the Profiling Radiometer. The tripod is shown in Figure 8 with a MP-3000A radiometer and optional Azimuth Positioner mounted. Detailed tripod assembly instructions are included in **Appendix A**.

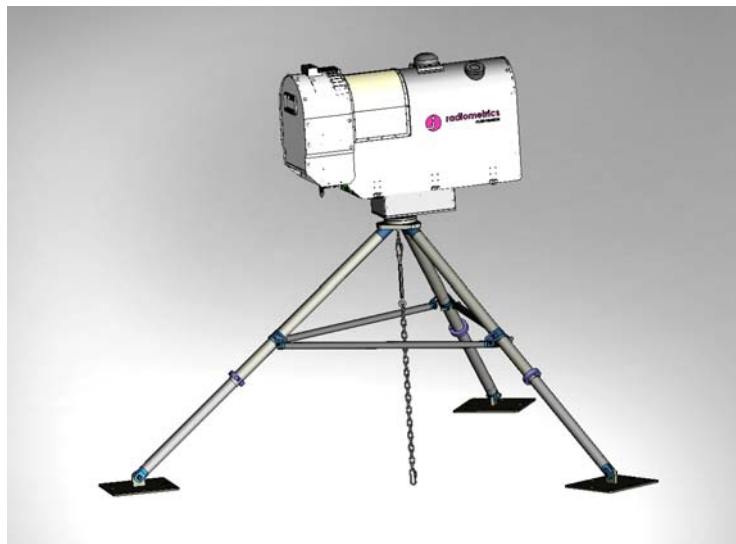

Figure 8 Tripod and anchor chain with Profiling Radiometer.

CAUTION: The instrument should be handled only by its lifting handles or its base. It is strongly recommended that two people be available to mount the radiometer on the tripod.

NOTE: The instrument cover, which contains a foam dielectric radome, must not be used to support or lift the Profiling Radiometer. The microwave radome will be degraded by abrasive contact and foreign matter. It should not be touched intentionally.

3.4 Leveling the Tripod

Before installing the Profiling Radiometer, the mounting surface must be leveled using the bubble level supplied with the TP-2000 Tripod (or similar). The instrument must be mounted on a level surface to ensure accurate antenna elevation angles and TIP calibrations. If the triangular Tripod Top Plate is not level within $1/8^{\text{th}}$ of a bubble in all directions when the tripod is in position at the installation site, adjust one or more of the telescoping tripod legs to different lengths as required to make it level. First, align the level in the plane of the leg to be adjusted first. Then loosen the leg collar clamp on that leg using the $1/4^{\text{th}}$ Allen wrench as shown in Figure 9. The lower leg will slide freely inside the upper leg. To adjust the leg length, move the lower leg up or down as necessary. When the bubble in the level is centered, tighten the collar clamp. Repeat for each leg as necessary to make the triangular Tripod Top Plate level in all directions.

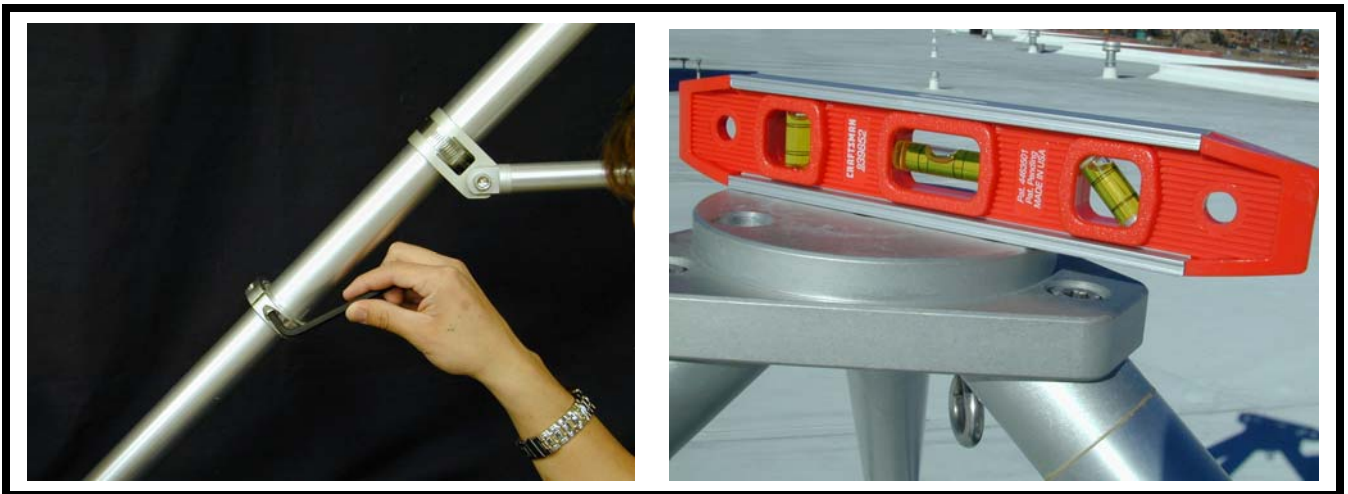

Figure 9 Leveling the TP-2000 Tripod

3.5 Securing the Tripod

Secure the tripod to the ground or building roof using one of the methods recommended in **Appendix A**. The supplied center pull anchor chain and turnbuckle provide a robust, flexible way to secure the tripod to the surface below using a single eyebolt. This method is especially useful when the height may need to be adjusted from time to time. The addition of anchor bolts in the feet is advised if the height and location are permanent. After securing the tripod, check to make sure it is still level, *as secured*. If the tripod is not level within $1/8^{\text{th}}$ bubble, loosen the chain and/or foot security bolts/stakes as required, and refine the leveling as described in Section 3.4. Then retighten all fasteners.

3.6 Mounting the Profiling Radiometer

NOTE: Before proceeding with this step, if the center pull chain method is used to secure the tripod, the chain should be *temporarily* loosened as required to turn the T-bolt to mount the Profiling Radiometer.

Using the lifting handles located on each end of the Profiling Radiometer, lift the Profiling Radiometer from its shipping container. If the optional Azimuth Positioner is to be installed, follow the separate instructions supplied with the Azimuth Positioner to install it on the bottom of the Profiling Radiometer. Place the Profiling Radiometer (with Azimuth Positioner if installed) on the Tripod Top Plate and secure with the 5/8-11 T-bolt. The connector panel should be oriented due east.²⁷ If the center pull chain was loosened, retighten the chain.



Figure 10 Securing the Profiling Radiometer with the T bolt

²⁷ If the optional Azimuth Positioner is not installed, orienting the connector panel due east will result in elevation angle pointing in a north-south plane, with 0 degrees elevation due north, 90 degrees zenith and 180 degrees due south. If the user prefers a different elevation scanning plane, adjust the azimuth accordingly.

3.7 Attaching the Power Cable

To ensure safe operation, the power cable must be connected to a properly grounded mains receptacle. The power cable is normally supplied with a mains connector pre-installed for the receptacles used in the region to which the Profiling Radiometer is delivered.

Always disconnect the power cable from the main supply *before* disconnecting the cable from the Profiling Radiometer. This ensures ground integrity in case of a fault condition. Only qualified personnel should service this equipment. Hazardous voltages are accessible between the Front Panel and the Power Supply after removal of the cabinet hood.



Locate the connector panel at the base of the Profiling Radiometer, on the SuperBlower end, as shown in Figure 11.



Figure 11 Front Panel

Mate the power cable plug and secure by rotating the locking collar into the detents. Connect the other end of the power cable to the mains receptacle. The Profiling Radiometer can be protected from power failures by utilizing an uninterruptible power supply (UPS). The power cable should be connected to a grounded outlet for safety, as well as static and transient protection.

3.8 Attaching the Data Cable

The RS422 Data Cable connects the Profiling Radiometer to the Control Computer. This cable has an RS422 to USB converter on the Control Computer end. If the cable is to be

installed in a conduit, the end with the circular connector should be pulled through the conduit from the Control Computer end.

Plug the USB connector into any available USB port on the Control Computer. Drivers for the USB adaptor are preinstalled. The circular connector end of the RS422 data cable should be plugged into the Profiling Radiometer RS422 port marked "Computer RS422" in Figure 11.



NOTE: An auxiliary RS422 port is furnished for special applications. Due to the wide variety of protocols that RS422 connected devices use, the standard Operating Code does not support the use of this port. Contact Radiometrics for information on custom versions of the Operating Code if the use of this port is desired.

3.9 Securing the Cables

The cables should be secured to a tripod leg using tie wraps or tape. If the optional Azimuth Positioner is installed, it is necessary to provide a service loop in the cable bundle as shown in Figure 12 so that it does not become restricted when the Profiling Radiometer changes azimuth position.



Figure 12 Cable service loop for use with Azimuth Positioner

3.10 Installing the Control Computer

All software and files needed for the normal operation of the Profiling Radiometer are preinstalled on the Control Computer by Radiometrics. **Substitution of another computer for the unit supplied by Radiometrics, or changing the factory software load and settings, automatically voids our Warranty Support Obligation. Should such changes result in need for RDX remote support, these services are to be paid for at our normal hourly support rates.** The single-user Operating Code (mp_4.32.exe or similar) and all associated input files (configuration file, neural network files, Procedure Files) are stored in one folder referred to herein as the “Operating Folder”. The Operating Folder can have any name, and it can be located anywhere within the disk directory structure. As delivered from the factory, “shortcuts” (aliases) for the Operating Folder, Operating Code, Microsoft Notepad (Notepad) and Windows Task Scheduler are located on the desktop. All output files are stored in the Operating Folder.

The standard Panasonic Toughbook CF-52 Control Computer should be located in a suitably protected indoor environment. Connect the USB connector on the data cable to an available USB port on the left side. Normally, the RS422 serial port driver is installed and associated with COM4 in the Windows XP Operating System. If a different serial port has been assigned to the RS422 adaptor, then the associated com port should be specified in the configuration file (mp.cfg) to match the RS422 serial port in use. To change the com port in the configuration file from the default value of 4, open the mp.cfg file using Notepad. Change the number defining the com port, then save the file.



Figure 13 Standard CF-52 on left; Optional Rugged Mobile Computer on right

If the optional rugged mobile computer has been selected, it can be installed outdoors inside a NEMA4 or similar rated enclosure (-40 to +60C operating temperature). The mobile computer is not supplied with a monitor, keyboard or mouse. Instead, it is provided with VNC Server software. To access the mobile computer, it must be connected to a network. The user must then log in from another computer using VNC Viewer software, supplied with the rugged Control Computer option.



4 Initial Operation and Test of the Instrument

To begin operation of instrument, locate the power switch on the connector panel of the Profiling Radiometer and move it to the ON (up) position. The SuperBlower will start. If installed, the optional Azimuth Positioner may turn to seek its index position, and the elevation stepper motor will be heard stepping to its index position. Once the Profiling Radiometer reaches its azimuth index position, it must be reoriented to align the antenna to the north-south observation plane. To align the Profiling Radiometer, loosen the T-bolt slightly and gently rotate the Profiling Radiometer so that the connector panel points due east, and then re-tighten the T-bolt. This alignment only needs to be performed the first time the Profiling Radiometer is turned on after installation, or after movement of the tripod or Profiling Radiometer.

NOTE: Orienting the connector panel end of the instrument to the east sets the pointing direction of the mirror in a north-south plane, the reference plane for observations. Any error in this orientation will result in an equivalent error in azimuth pointing direction. The user may want to use a compass for this orientation. If so, the magnetic declination at the installed site must be included in the determination of true north.

NOTE: If the SuperBlower is not heard when power is first turned on, check the fuse in the connector panel (Figure 11) by turning the fuse cap counterclockwise, removing the fuse, and visually inspecting. If in doubt, use a DVM (Digital Volt Meter) set to continuity or resistance to test for continuity. If the fuse is good, check the power source with a DVM (set to AC voltage). If unable to determine the cause of the lack of power, contact Radiometrics for assistance.

NOTE: Before attempting to calibrate the instrument or collect data, the instrument must reach its stable operating temperature. If the Profiling Radiometer is initially in equilibrium with ambient air temperature, it will require up to 30 minutes for the microwave receivers to thermally stabilize (depending on the ambient temperature). Immediately following the movement of the Profiling Radiometer from one environment to another (i.e., from a warm warehouse to cold outdoors), then up to 5 hours may be required for the Profiling Radiometer to reach complete equilibrium. The Profiling Radiometer may be operated safely during the period it is stabilizing, but the data may be slightly biased.

Locate the Control Computer power switch and turn it on. The computer will start and the Windows XP Pro Desktop will appear on screen.²⁸

To start the Operating Code, double click the Operating Code shortcut icon on the Windows XP Pro Desktop. This will load the Profiling Radiometer program (mp_4.32.exe or similar). Diagnostic tests will be automatically performed immediately. Then the Control Computer will display an array of small housekeeping data graphs (sometimes referred to as “engineering data”) that indicate the state of the instrument. Figure 14 shows the display following a successful power on test of the MP-3000A. When the graphs of *Tknd0* (K band noise diode physical temperature) and *Tknd1* (V band noise diode physical temperature) stabilize at 323.15 ± 0.1 K (+50.0C), the receivers have reached thermal stability, and observations can be started.²⁹ (Note: The MP-1500A, MP-2500A and MP-183A single band Profiling Radiometers only display information for one receiver, rcvr0).

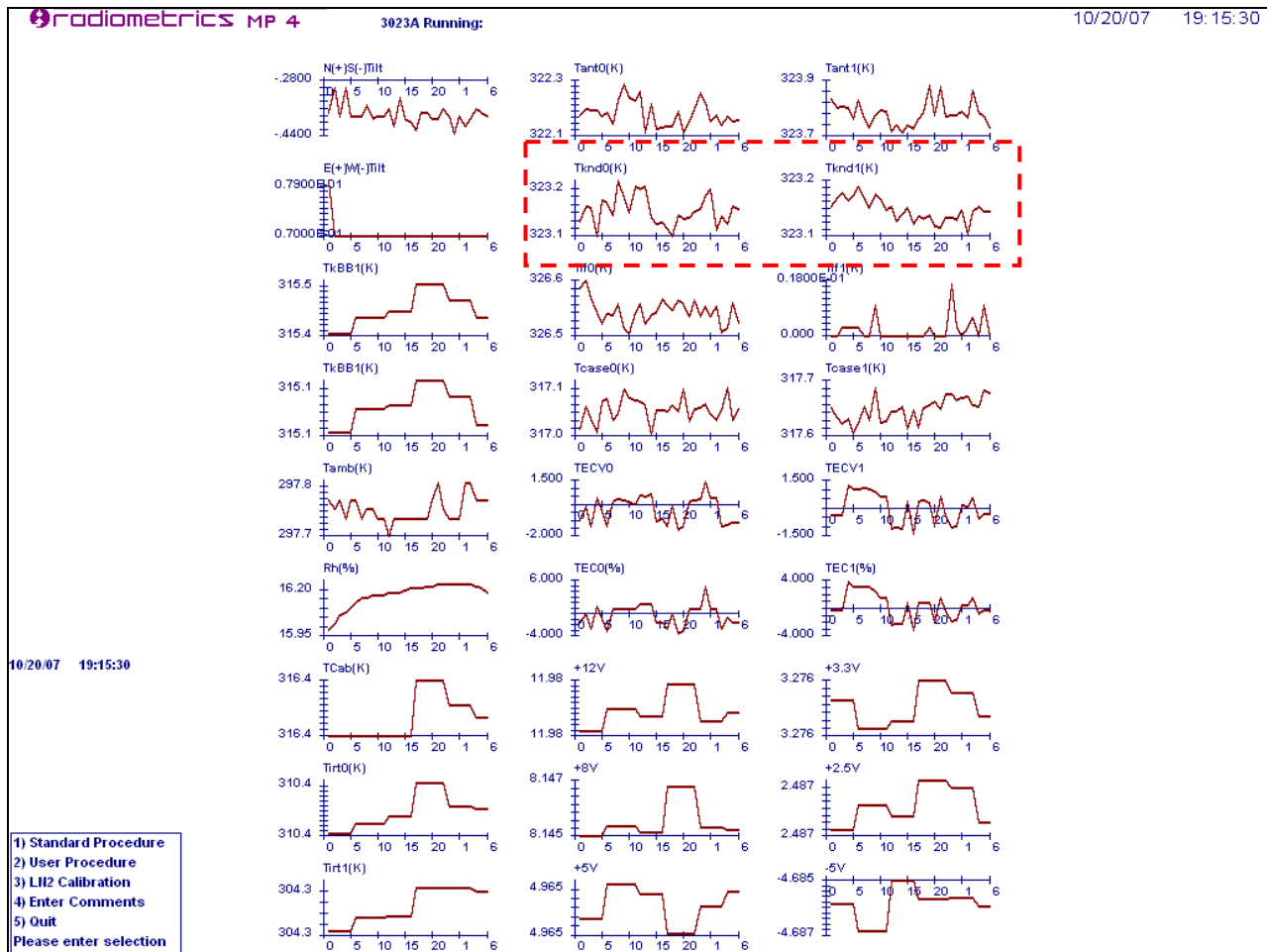

Figure 14 Operating Code display after power-on tests have completed.

²⁸ If VizMet-B has been installed, the radiometer will automatically begin operation after turning on the control computer. See VizMet-B Operator Manual for details.

²⁹ The normal receiver operating temperature is factory set to +50C, but may be changed at the factory for special cases.

NOTE: If the cursor is moved to the lower edge of the screen while in Windows XP, the full screen display will change to a windowed display with scroll bars at the side and bottom of the screen. Other programs can then be selected from the bottom tool bar. To return to full screen, press **Alt-Enter**.

The main menu is displayed in the lower left corner of Figure 14, and enlarged in Figure 15 below.

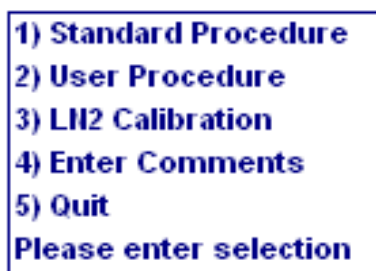

Figure 15 Main Menu Screen

From the Main Menu, the user may select from these 5 options:

1. Standard Procedure	Choose this option to select from a list of standard factory supplied procedures.
2. User Procedure	Choose this option to select from a list of previously written user defined procedures.
3. LN2 calibration	Choose this option to perform a user LN2 calibration using the external Cryogenic Target.
4. Enter Comments	Use this option to enter a brief note (free form text) that will be appended to the next level0 data file.
5. Quit	Causes the Operating Code to terminate execution after an orderly shutdown.

NOTE: The radiometer may be operated immediately after installation, but it should be recalibrated before “official” data collection begins, and after any transport.

To begin observations immediately using the Manual Mode and a factory-preconfigured procedure, choose option 1 (press the “1” key). The next screen will display the available standard procedures one at a time by scrolling through the list using the “<” and “>” keys.

Scroll to the procedure named “TEST1.prc” and press “Enter” to begin. TEST1.prc is a procedure that will exercise most of the instrument observation functions. For the MP-3000A, it logs 48 housekeeping data values, the GPS time, date and position, performs

a 35 channel receiver temperature calibration, a 21 channel TIP calibration, observes all 35 zenith brightness temperatures, and performs a 26 input neural network retrieval.³⁰

After a few observation cycles, the screen will display a set of real-time graphics similar to those in Figure 16. The user may toggle between the three screens illustrated in Figure 16, Figure 17 and Figure 18 below to see views of Level1 data, Level2 data and TIP calibration data. Toggle the screens by pressing the **1**, **2** and **T** keys.

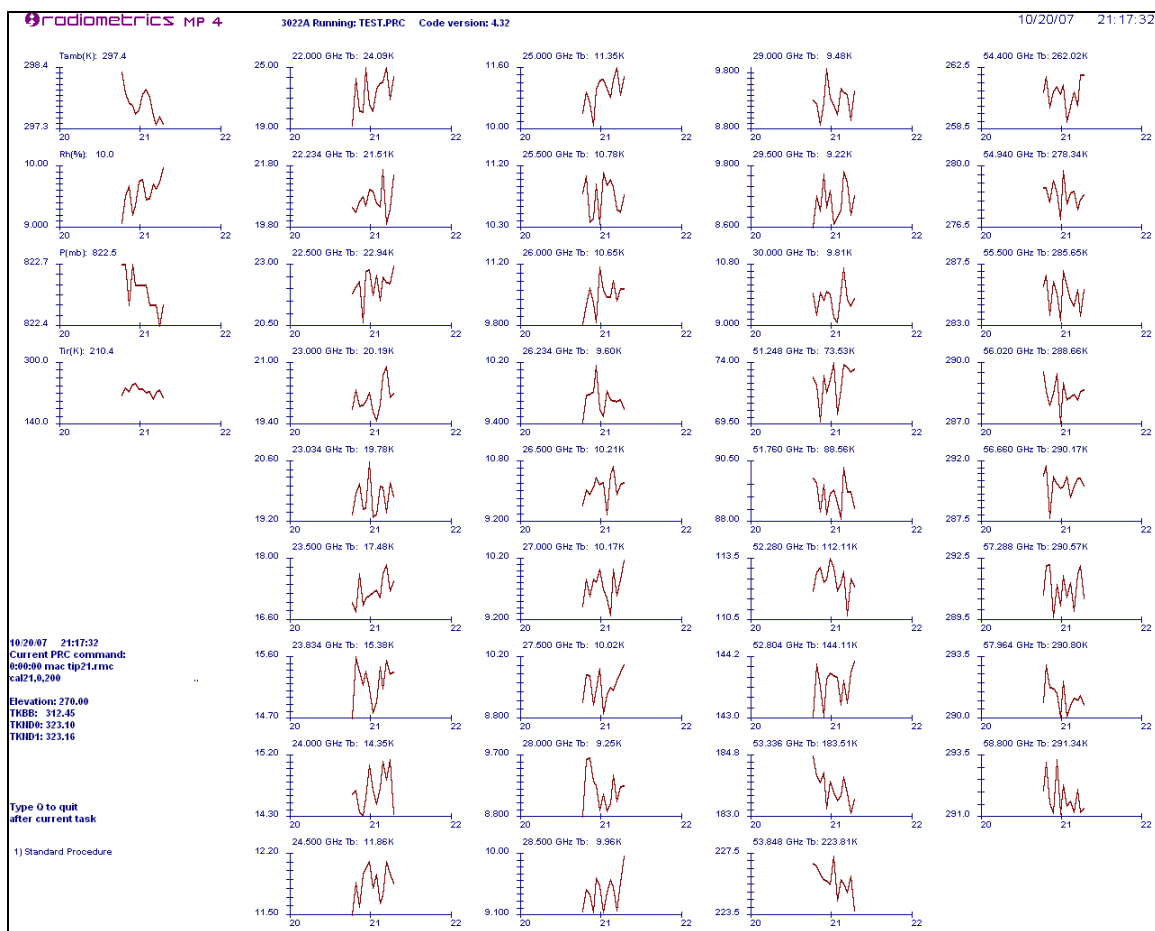

Figure 16 Press 1 for Level1 data (brightness temperature)

³⁰ Procedure files are updated and changed frequently. If the radiometer operating directory has been updated, this procedure file may not be present. If the procedure TEST1.prc is no longer available, try any other procedure that performs periodic retrievals. See Section 6.2.2 for information on writing procedures.

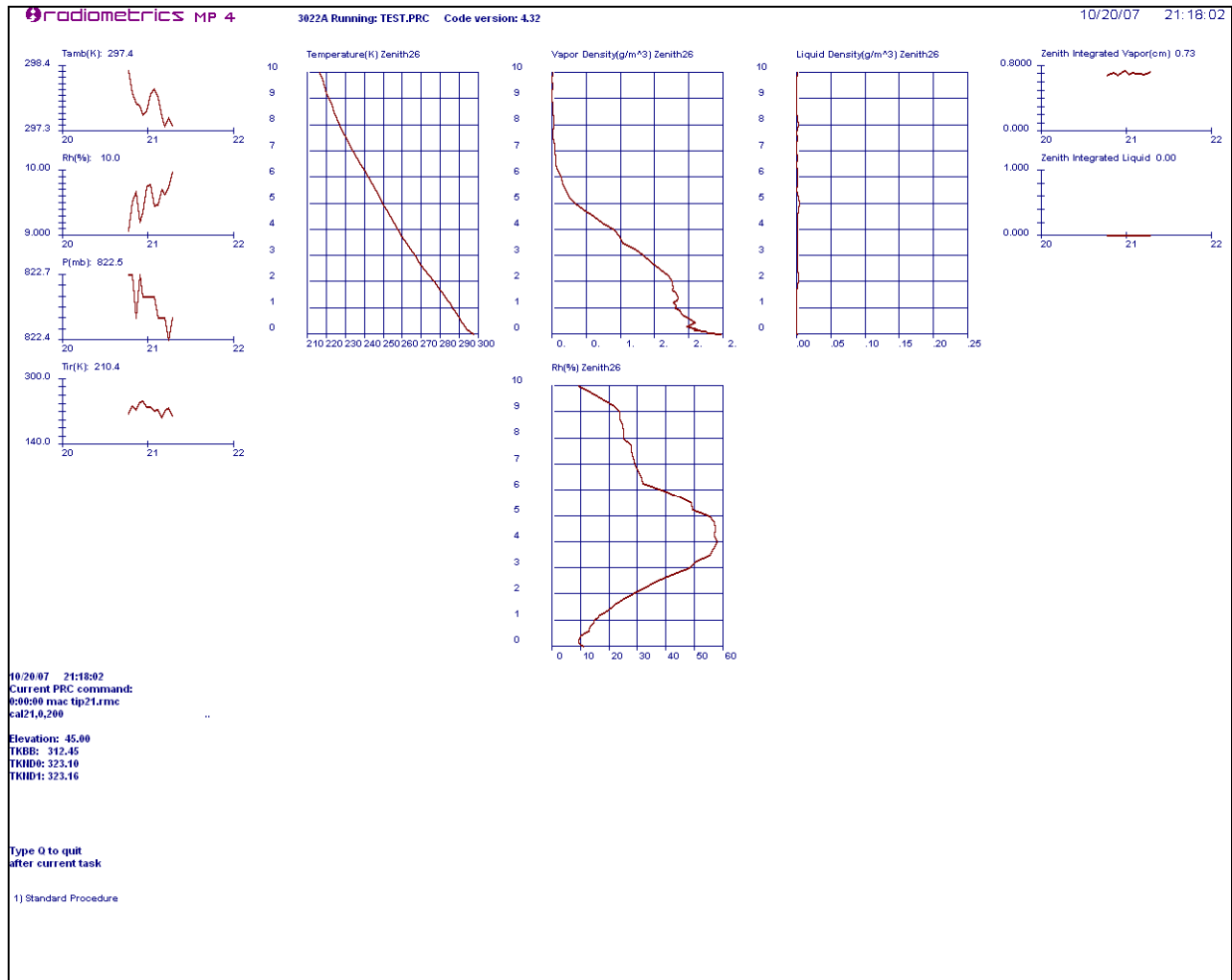

Figure 17 Press 2 for Level2 data (profiles and integrated values)

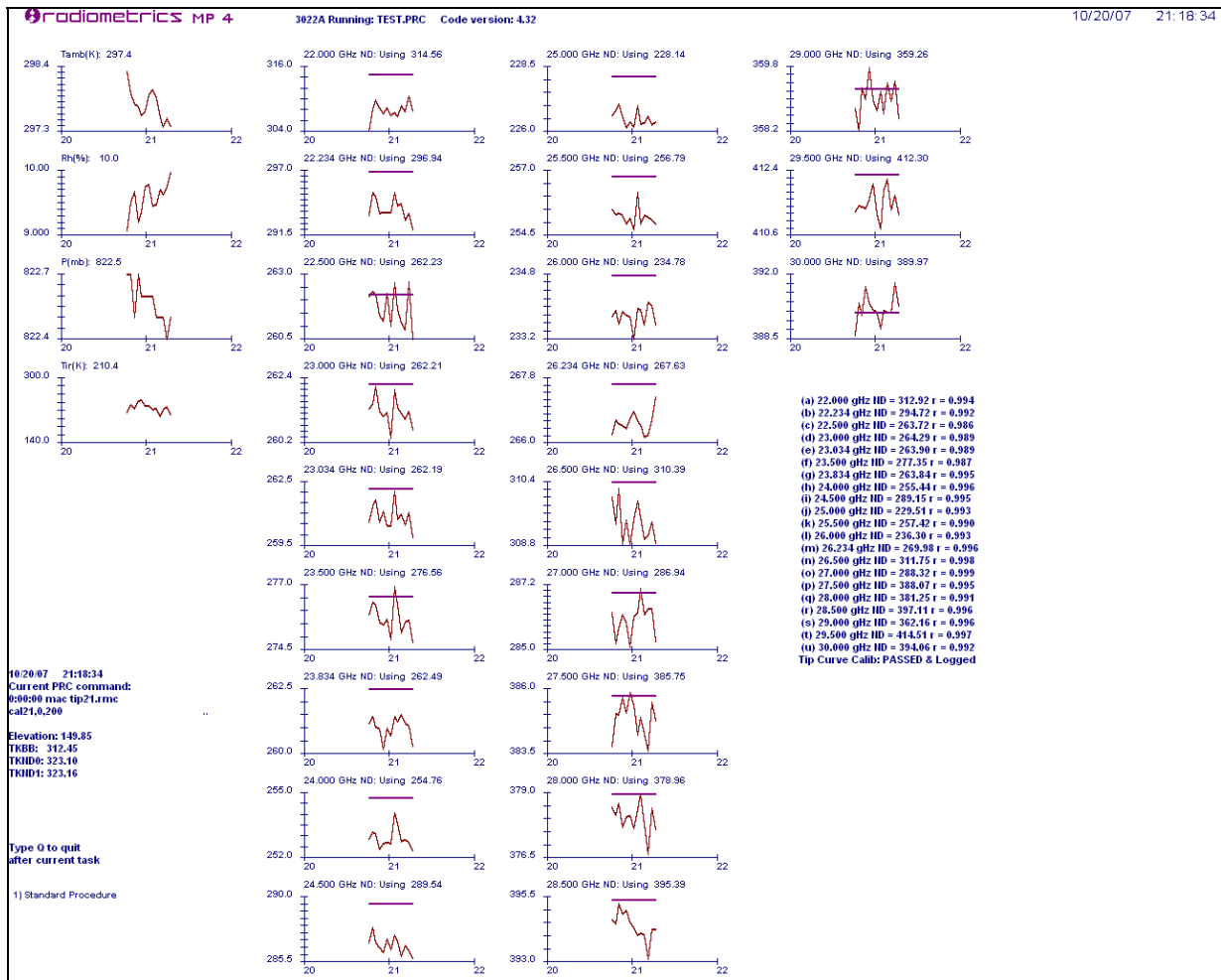

Figure 18 Press T for TIP Calibration Display; K band Noise Diode calibrations

The graphical displays illustrated in Figure 16, Figure 17 and Figure 18 are selected by pressing a single key as follows:

- **1** View brightness temperatures for all channels
- **2** View Profiles of temperature, RH, Vapor and liquid, and time series of integrated vapor and liquid
- **T** View TIP Calibration derived values of Tnd

NOTE: The availability of **1**, **2** and **T** displays will depend on the procedure file used.

For the limited purpose of this initial test, it is sufficient to verify that the instrument and software produce displays similar to those viewed above. To terminate the test, press the “Q” key. This causes the Operating Code to stop in an orderly manner after completing the current observation. Section 0 provides a more detailed description of the operation of the instrument.

Caution: Ending the program by closing the window may corrupt data files.

This completes the basic post installation check and tests. Data files may be opened in Microsoft Excel to view and verify the data collected. To sort the data into logical blocks with the appropriate header record associated with each logical block, use the Excel "Data/Sort" command, and sort by column C (record type). Data in the files produced by the test can be plotted to help verify data consistency. Figure 19 is an example of level1 brightness temperature data plotted for observations on the 8 K band and 14 V band channels normally used for zenith profiles produced by the MP-3000A.

Boulder Colorado Level 1 Brightness Temperatures

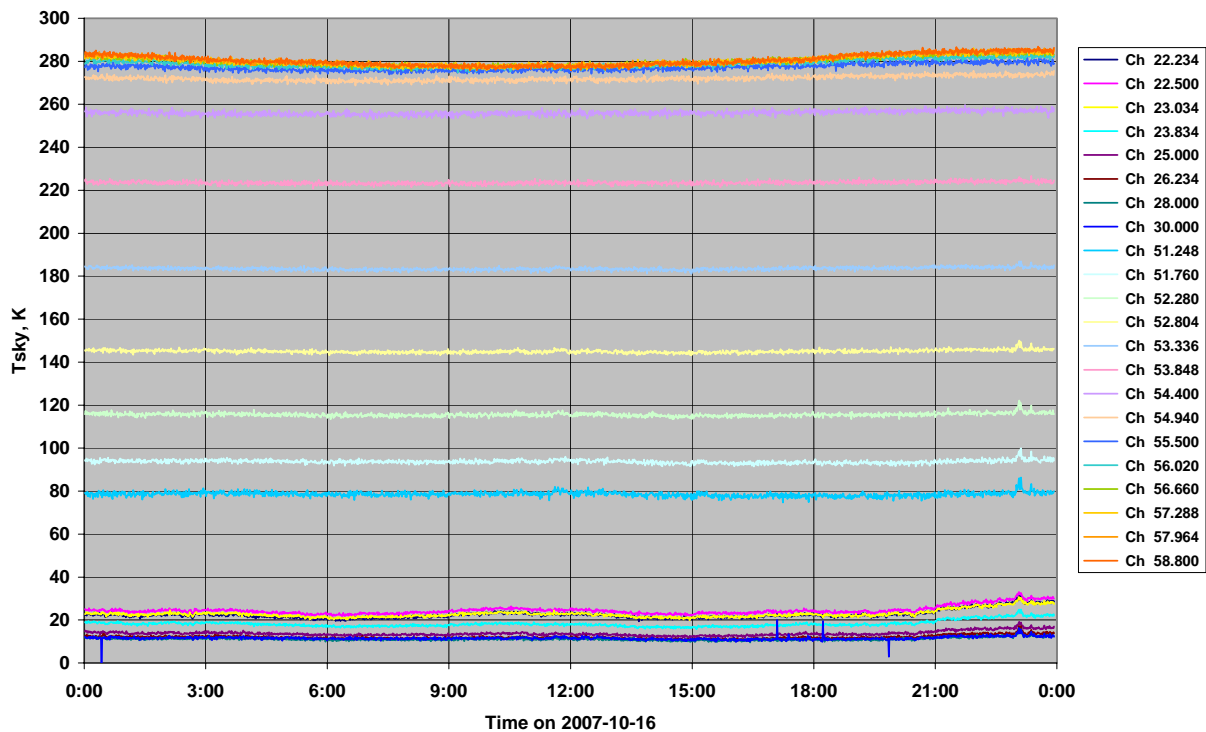

Figure 19 Example of Level1 brightness temperature time series plotted in Excel

Detailed instructions for instrument configuration and operation begin at Section 6. Before beginning operations for the first time, users are urged to read Sections 5 and 6. Even if the user chooses not to calibrate the Profiling Radiometer or Met Sensors at this time, the information contained in Sections 5 provides part of the background required to choose the best configuration for operation of the instrument. For the highest accuracy observations, the instrument should always be recalibrated after transport.

5 Radiometer Calibration

There are seven parameters associated with every microwave channel that are individually calibrated to provide the highest level of accuracy over all operating conditions. The surface met sensors also contribute to the accuracy of level2 data products. Most of the Profiling Radiometer parameters that require calibration remain stable for many years. All these parameters are calibrated at the factory, *over the full operating temperature range*, and normally require no user adjustment. The seven factory-calibrated parameters associated with each microwave channel are:

- alpha linearity correction exponent
- dTdG 1/f noise suppression coefficient
- K1 zero order coefficient of Tnd temperature dependent correction
- K2 1st order coefficient of Tnd temperature dependent correction
- K3 2nd order coefficient of Tnd temperature dependent correction
- K4 3rd order coefficient of Tnd temperature dependent correction
- Tnd@290 effective Noise Diode Temperature at TkBB = 290K

These seven parameters are used to compute brightness temperature in accordance with the transfer function described above in Section 1.4.

The *effective* Noise Diode Temperature (Tnd) is very stable, but it should be recalibrated after transport of the instrument, and once every 3-6 months to ensure the highest accuracy. Two methods are available to calibrate the Noise Diode “secondary gain standards” using “primary standards”. The “LN2 calibration method” is applicable to all microwave channels in all models. The “TIP calibration method” is only applicable to the relatively transparent K band channels in the MP-1500A and MP-3000A models. Each method has strengths and weaknesses described below.

The instrument configuration file (mp.cfg) contains all the settings and parameters associated with the operation of an instrument. The Channel Calibration Block in the configuration file contains the factory calibration data unique to each instrument RF subsystem. It contains data for each channel in each receiver (22-30, 51-59, and 170-183.6 GHz as applicable). Figure 20 shows an example of a typical Channel Calibration Block for the 35 channel MP-3000A.

Note: Except as noted below, values in this table should not be changed unless directed to do so by factory service personnel.

CALIBRATION BLOCK:											
2006/08/11 22:22:39 Date of last factory LN2 calibration											
2007/03/02 18:03:04 Date of last user LN2 calibration											
.90 :target tolerance for ln2 cal											
35 :number of frequencies											
Frequency	MRT	Window Coef	ND drive	IF Atten	alpha	dtgd	k1	k2	k3	k4	Tnd
22.000	275.0	0.000140	22000	18.5	1.0564	-8.89E+05	-7.51E+00	3.85E-02	-6.53E-05	7.53E-08	173.250
22.234	275.0	0.000140	22000	18.5	1.0437	-7.98E+05	-7.01E+00	1.01E-01	-5.24E-04	8.98E-07	155.140
22.500	275.0	0.000140	22000	18.5	1.0360	-7.91E+05	-2.16E+02	2.24E+00	-7.80E-03	9.12E-06	151.090
23.000	275.7	0.000140	22000	18.5	1.0218	-6.50E+05	-5.21E+01	4.92E-01	-1.61E-03	1.84E-06	144.360
23.034	275.7	0.000140	22000	18.5	1.0238	-6.53E+05	3.69E+01	-4.37E-01	1.61E-03	-1.87E-06	143.920
23.500	275.7	0.000140	22000	18.5	1.0181	-6.02E+05	-5.47E+01	5.40E-01	-1.85E-03	2.19E-06	159.320
23.834	276.0	0.000150	22000	18.5	1.0154	-6.53E+05	6.07E+00	-6.93E-02	1.81E-04	-4.79E-08	151.430
24.000	275.7	0.000140	22000	18.5	1.0184	-6.73E+05	-2.47E+01	2.18E-01	-6.54E-04	6.73E-07	145.060
24.500	275.7	0.000140	22000	18.5	1.0394	-7.63E+05	-3.68E+01	3.33E-01	-1.03E-03	1.11E-06	184.940
25.000	275.4	0.000164	22000	18.5	1.0519	-9.40E+05	1.33E+01	-1.59E-01	5.32E-04	-4.93E-07	141.490
25.500	275.4	0.000164	22000	18.5	1.0592	-9.36E+05	-1.28E+01	9.46E-02	-3.20E-04	5.06E-07	158.860
26.000	275.4	0.000164	22000	18.5	1.0712	-8.00E+05	3.20E+01	-3.60E-01	1.27E-03	-1.43E-06	137.290
26.234	275.4	0.000164	22000	18.5	1.0723	-7.10E+05	5.81E+01	-6.20E-01	2.13E-03	-2.34E-06	143.860
26.500	275.4	0.000164	22000	18.5	1.0685	-6.58E+05	-2.13E+01	2.44E-01	-1.02E-03	1.47E-06	168.390
27.000	275.4	0.000164	22000	18.5	1.0629	-5.87E+05	3.20E+01	-3.88E-01	1.46E-03	-1.72E-06	160.490
27.500	275.4	0.000164	22000	18.5	1.0537	-5.80E+05	-8.01E+01	8.46E-01	-3.08E-03	3.85E-06	187.580
28.000	275.4	0.000164	22000	18.5	1.0444	-6.39E+05	-3.38E+01	2.80E-01	-7.93E-04	7.88E-07	210.880
28.500	274.1	0.000200	22000	18.5	1.0407	-7.84E+05	-1.29E+02	1.32E+00	-4.64E-03	5.55E-06	213.600
29.000	274.1	0.000200	22000	18.5	1.0397	-1.11E+06	-1.22E+02	1.28E+00	-4.54E-03	5.45E-06	234.990
29.500	274.1	0.000200	22000	18.5	1.0347	-9.59E+05	-1.94E+02	2.03E+00	-7.11E-03	8.37E-06	189.640
30.000	274.1	0.000200	22000	18.5	1.0315	-1.21E+06	-8.08E+01	8.77E-01	-3.26E-03	4.11E-06	184.890
51.248	274.1	0.000200	45000	20.5	1.0500	-8.56E+05	2.01E+01	-1.14E-01	-2.95E-05	6.37E-07	181.500
51.760	274.1	0.000200	45000	20.5	1.0570	-1.28E+06	-4.52E+01	4.90E-01	-1.86E-03	2.46E-06	192.020
52.280	274.1	0.000200	45000	20.5	1.0590	-7.56E+05	-1.90E+01	2.16E-01	-9.93E-04	1.64E-06	226.450
52.804	274.1	0.000200	45000	20.5	1.0566	-7.62E+05	-4.76E+01	4.01E-01	-1.25E-03	1.50E-06	218.580
53.336	274.1	0.000200	45000	20.5	1.0512	-7.13E+05	-8.90E+01	9.01E-01	-3.22E-03	4.04E-06	165.690
53.848	274.1	0.000200	45000	20.5	1.0507	-7.36E+05	-1.06E+02	1.07E+00	-3.63E-03	4.20E-06	136.590
54.400	274.1	0.000200	45000	20.5	1.0547	-7.46E+05	-6.54E+00	3.19E-02	-8.58E-05	1.84E-07	138.260
54.940	274.1	0.000200	45000	20.5	1.0634	-9.87E+05	7.78E+01	-7.68E-01	2.40E-03	-2.32E-06	158.610
55.500	274.1	0.000200	45000	20.5	1.0600	-9.65E+05	-2.63E+01	2.35E-01	-8.44E-04	1.20E-06	168.490
56.020	274.1	0.000200	45000	20.5	1.0504	-7.68E+05	1.76E+01	-2.27E-01	8.05E-04	-8.00E-07	143.740
56.660	274.1	0.000200	45000	20.5	1.0603	-8.32E+05	-2.10E+01	2.05E-01	-7.54E-04	1.02E-06	118.280
57.288	274.1	0.000200	45000	20.5	1.0680	-1.06E+06	-4.07E+01	4.01E-01	-1.39E-03	1.70E-06	124.880
57.964	274.1	0.000200	45000	20.5	1.0545	-8.97E+05	9.25E+00	-8.72E-02	1.71E-04	6.80E-08	146.690
58.800	274.1	0.000200	45000	20.5	1.0574	-1.28E+06	-3.17E+01	2.92E-01	-9.91E-04	1.25E-06	138.380

Figure 20 Example of Channel Calibration Block in Configuration File

5.1 LN2 Calibration

The Noise Diodes in Profiling Radiometers are used as the “secondary standard” to measure *system gain* in each channel for each observation. When enabled, they add a calibrated increase to the brightness temperature. When the value of Tnd is not known, it can be determined by observing two targets of known temperature. In the fully automated method used by Radiometrics, the built in ambient Black Body target provides one target of known temperature for the calibration, and an external Cryogenic Target, filled with LN2, provides the second. The ambient target physical temperature (TkBB) is measured by the instrument each time a **Trcvcal** command is executed. The effective target temperature of the Cryogenic Target is calculated automatically by the Operating Code, based on “first principles” as described in section 5.1.1.

5.1.1 Contributions to Cold Target Temperature

Temperature contributions to the patented cryogenic calibration target developed by Radiometrics include:

- insertion loss of the polystyrene insulation that contains the target and absorbing foam (the insertion loss contributes to temperature by re-radiating to the same extent as the absorption)
- reflection from the polystyrene-LN2 interface
- reflection from the surface of the absorbing foam that is immersed in LN2
- elevation in boiling point of the LN2 due to the hydrostatic pressure associated with the depth

These contributions are automatically taken into account by the automated calibration through coefficients held in the configuration file (mp.cfg).

The boiling point of LN2 (TLN2) is a weak function of ambient barometric pressure P:

$$TLN2(K) = 68.23 + 0.009037 * P(mb)$$

The physical temperature of the LN2 target is determined by the local LN2 temperature. The hydrostatic load must therefore be added to the atmospheric pressure at the surface of the LN2. This hydrostatic pressure enhancement is about 1.2 mb/cm of depth. At a 20 cm depth of LN2, the temperature increase is about 0.22° K. The various components contributing to the effective Black Body temperature are summarized in Table 3. An ambient temperature of 300° K and a target temperature of 77° K are assumed.

Contribution	Amount
Insertion loss at 55 GHz of polystyrene containing LN2	0.26° K
Air-polystyrene interface reflection	0.002° K
Polystyrene-LN2 interface reflection	1.74° K
LN2-absorbing foam interface reflection	0.00° K
Increase in boiling point due to 20 cm hydrostatic column of LN2	0.22° K
Total contribution at 300° K ambient temperature	2.22° K

Table 3 Typical contributions to Cryogenic Target Black Body temperature

5.1.2 LN2 Calibration Precautions

When performing the LN2 calibration, a number of precautions must be observed:

- To achieve the best possible calibration accuracy, the bottom of the target must be clean and dry. The Profiling Radiometer “looks” through the target bottom. Any dirt, debris, or moisture on the bottom of the target will contribute an error to the effective target temperature. If necessary, the target should be cleaned with mild soap and water, and allowed to thoroughly dry before use.
- The Profiling Radiometer must be at its stable operating temperature. Thus, the Profiling Radiometer should be turned on for a period of at least 30 minutes before the calibration begins. It is always best if the instrument has been on for several hours. (It is not necessary for the software to be running.)
- When LN2 is in the target, the outside will eventually cool, and may reach the atmospheric dewpoint temperature. This may cause condensation on the outside bottom surface of the target, which causes error. Therefore, the target should not be filled until shortly before calibration begins. The SuperBlower will help to minimize condensation, as will performing the calibration on days when the humidity is low (dewpoint is depressed). The user LN2 calibration may not produce accurate results if the ambient RH > 70%.
- The calibration procedure should be allowed to continue for 1-2 hours to obtain a large number of observations, thereby reducing measurement noise.

Warning: Contact with LN2 can cause burns and skin damage - - handle with care!

5.1.3 LN2 User Calibration Procedure

If the Profiling Radiometer has not been powered on for at least 1 hour, wait until it has been on for at least 1 hour, then proceed.

Unfold and install the Target Saddle over the Profiling Radiometer radome as shown in Figure 21. Note that the Target Saddle has a notch on one side to fit over the Rain sensor.



Figure 21 Calibration target and saddle.

Caution: The Target Saddle legs can damage the radome if they come in contact with the radome foam. Take care to install the Target Saddle so as to keep the legs from contacting the radome.

Fill the target with LN2. The target should be filled to a height of 30-50 mm above the black foam inside the target. Place the filled target on the Target Saddle as shown in Figure 21.

With the Profiling Radiometer stable (powered on for >1 hour) and the target in place, start the Operating Code in Manual Mode. Check the Tknd0 and Tknd1 temperatures for stability ($323.15\text{ K} \pm 0.1\text{ K}$ typical). When the instrument is ready, press **3** to start the LN2 Calibration. The calibration will begin automatically and continue until terminated by the user with a “**Q**” command (Quit). Allow the calibration to continue for 1-2 hours, provided that dry conditions prevail, and condensation on the target is not observed or expected. If condensation on the bottom of the target is likely to form, due to high humidity ($\text{RH} > 70\%$), then the calibration should be shortened to ~30 minutes.

During the calibration, the Operating Code will display the calibration elapsed time, and a graph of Tnd for each channel as shown in Figure 22. LN2 calibration observations are logged in a file named **yyyy-mm-dd_hh-mm-ss_In2.csv** where yyyy-mm-dd_hh-mm-ss is the start time of the calibration.

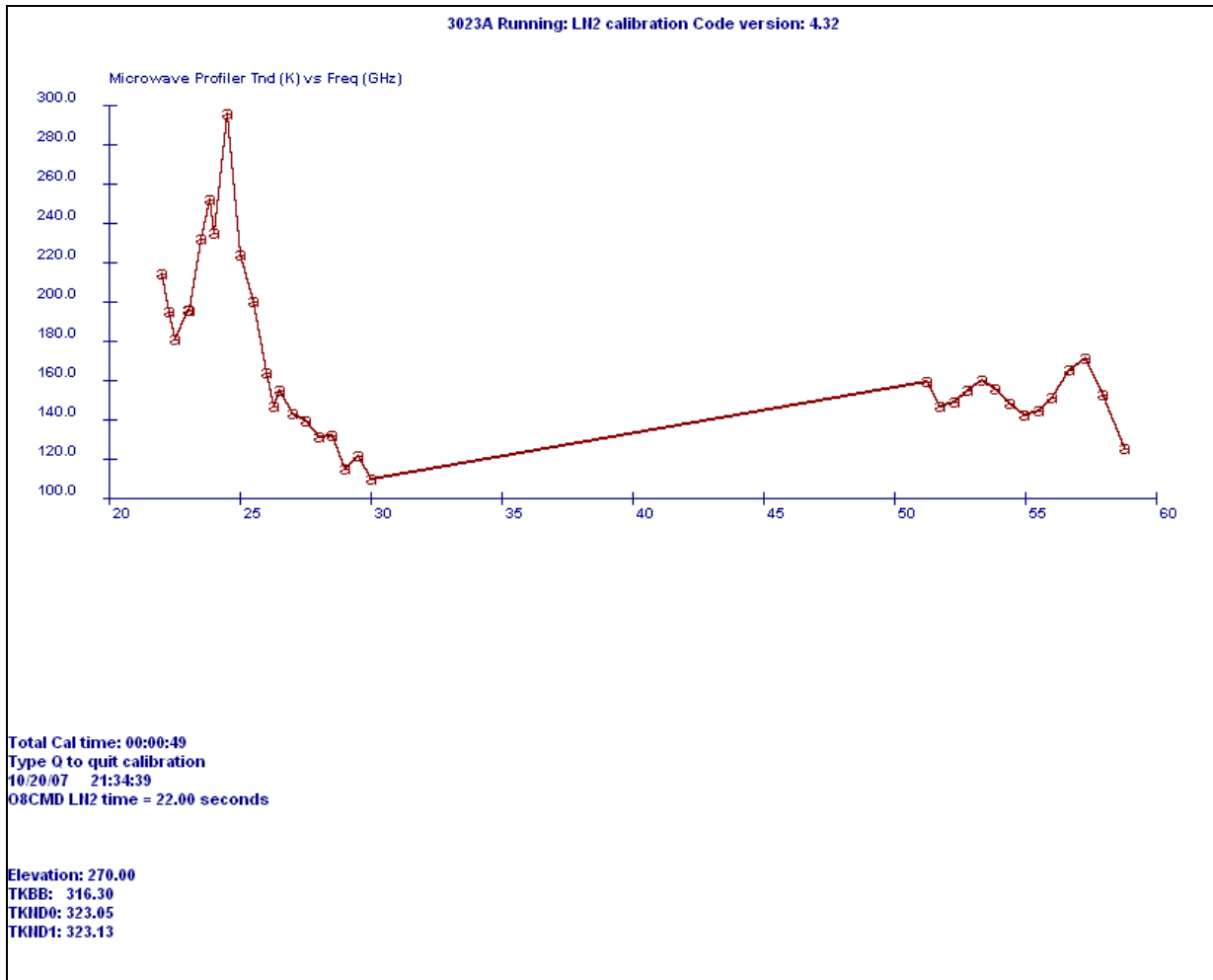

Figure 22 LN2 calibration display.

When the **Q** key is pressed to end the calibration, the Operating Code automatically computes new calibration values for alpha, dTdG, and Tnd for all channels, and then terminates execution. These values are written to the operational configuration file (mp.cfg), and the previous configuration file is archived with a file name indicating the date/time corresponding to the time of the calibration (i.e., 2007-01-10_18-29-16.cfg). The date of the user LN2 calibration is logged in the new configuration file in the Channel Calibration Block.

Two methods can be used to verify that the calibration completed correctly. First, the new and previous configuration files can be opened and inspected using the text editor Notepad. When closing these files, be sure *not* to “save changes”. Unless the calibration follows repairs or changes to the hardware, the new values of alpha, dTdG and Tnd should be close to the previous values. Typically, alpha will be in the range of 0.9 to 1.1, dTdG will be in the range of -100,000 to -5,000,000, and Tnd will be within 1-2% of the value computed in the previous known good calibration. Departure from these guidelines may indicate a poor calibration.

Second, to verify that moisture did not corrupt the calibration, open and plot the values of Tnd in the LN2 calibration file (**yyyy-mm-dd_hh-mm-ss_In2.csv**). If the values of Tnd are reasonably constant over time (only a small amount of random noise, but no long term drift

up or down), then the calibration is good. Figure 23 shows a plot of the data in a typical MP-3000A LN2 calibration file. It can be seen that all channels remain constant over the duration of the calibration, and the noise level is very low. These checks provide high confidence that a successful, accurate calibration has been achieved.

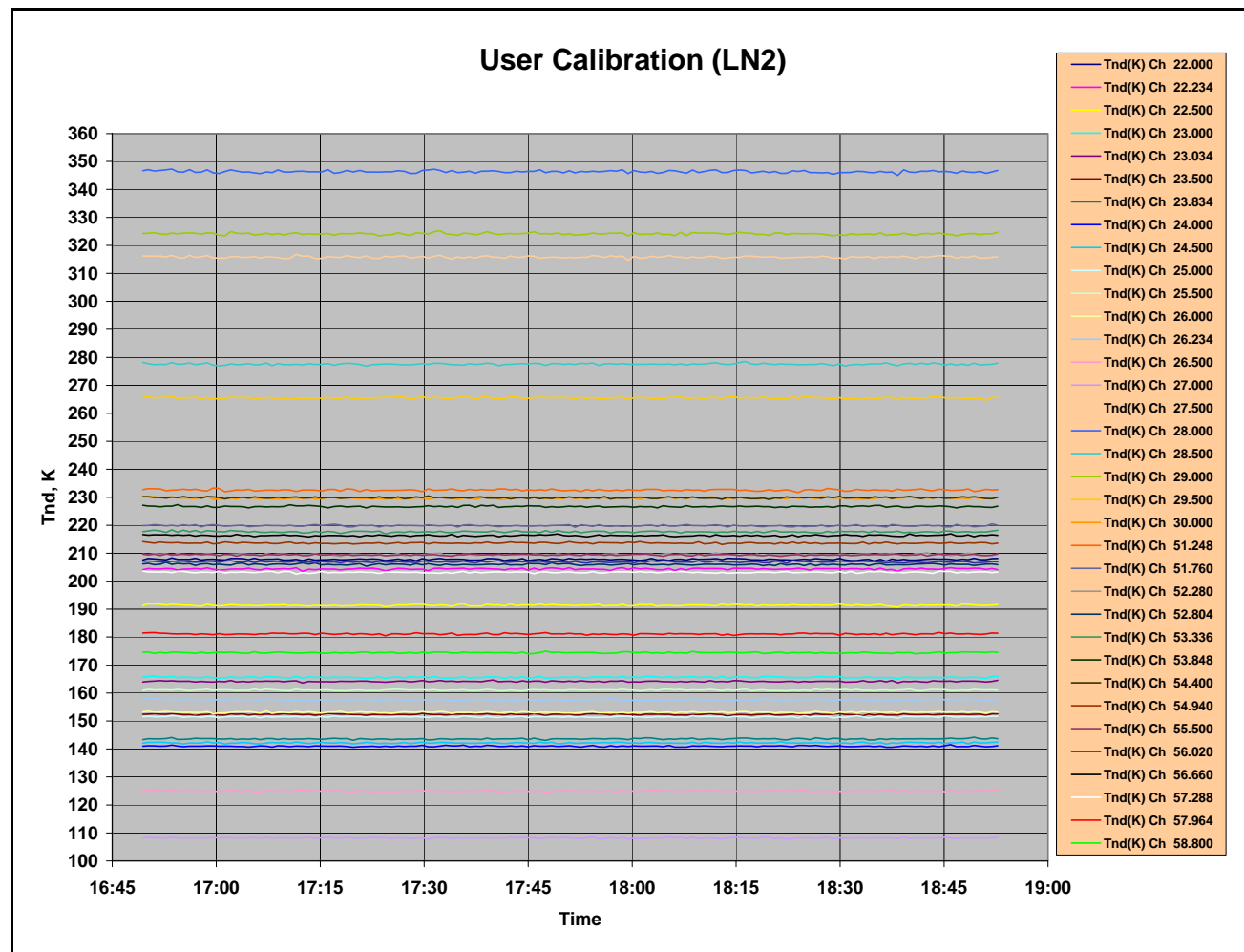

Figure 23 Excel Plot of Tnd values from User LN2 calibration

5.1.4 LN2 Calibration Verification Test

While the target is still on the saddle, the new calibration can be further verified by running a special procedure that alternates between views of the internal Black Body target (elevation angle = 270 degrees) and the external LN2 target (elevation angle = 90 degrees). It is best to start this verification immediately after the calibration completes, while the target still has sufficient LN2, and moisture has not started to build up on the bottom surface. A test Procedure File is included in the standard procedure list to do this. To run this procedure, restart the Operating Code (double click on the radiometer icon on the desk top), then select option **1** (Standard Procedure), then scroll to the Procedure File named B&L35.prc. Press **Return** to begin the verification procedure. Press **1** to select the Brightness Temperature Display. After a few observation cycles have completed, the display will begin showing the sky brightness temperature for all channels, switching back and forth between the internal ambient and external Cryogenic Targets.

If the calibration was successful, then the brightness temperatures for all channels should closely match the calculated values of the effective target temperature (typically, 77-80 K, depending on barometric pressure). If the target has not been moved on the saddle, and the LN2 level has not dropped below the black absorbing foam in the target, then the average of the LN2 target observation errors (observations minus effective target temperature) should be < 0.5 K. The average of the ambient target observation errors (target observation minus T_{kBB}) should be < 0.5 K.

It is sufficient to observe the Brightness Temperature Display for a few cycles of the procedure to verify that all channels were calibrated reasonably well. However, to calculate the errors more precisely, allow the B&L35.prc procedure to run for approximately 1-2 hours, then press **Q** to Quit. Open the new *level1* file in a spreadsheet or data analysis application to calculate the brightness temperature error ($T_{\text{observed}} - T_{\text{target}}$) for each record, and the average of the errors for each channel. Figure 24, Figure 25 and Figure 26. show examples of the data from a post user cal B&L test. See Section 0 for additional information on data files and data processing techniques.

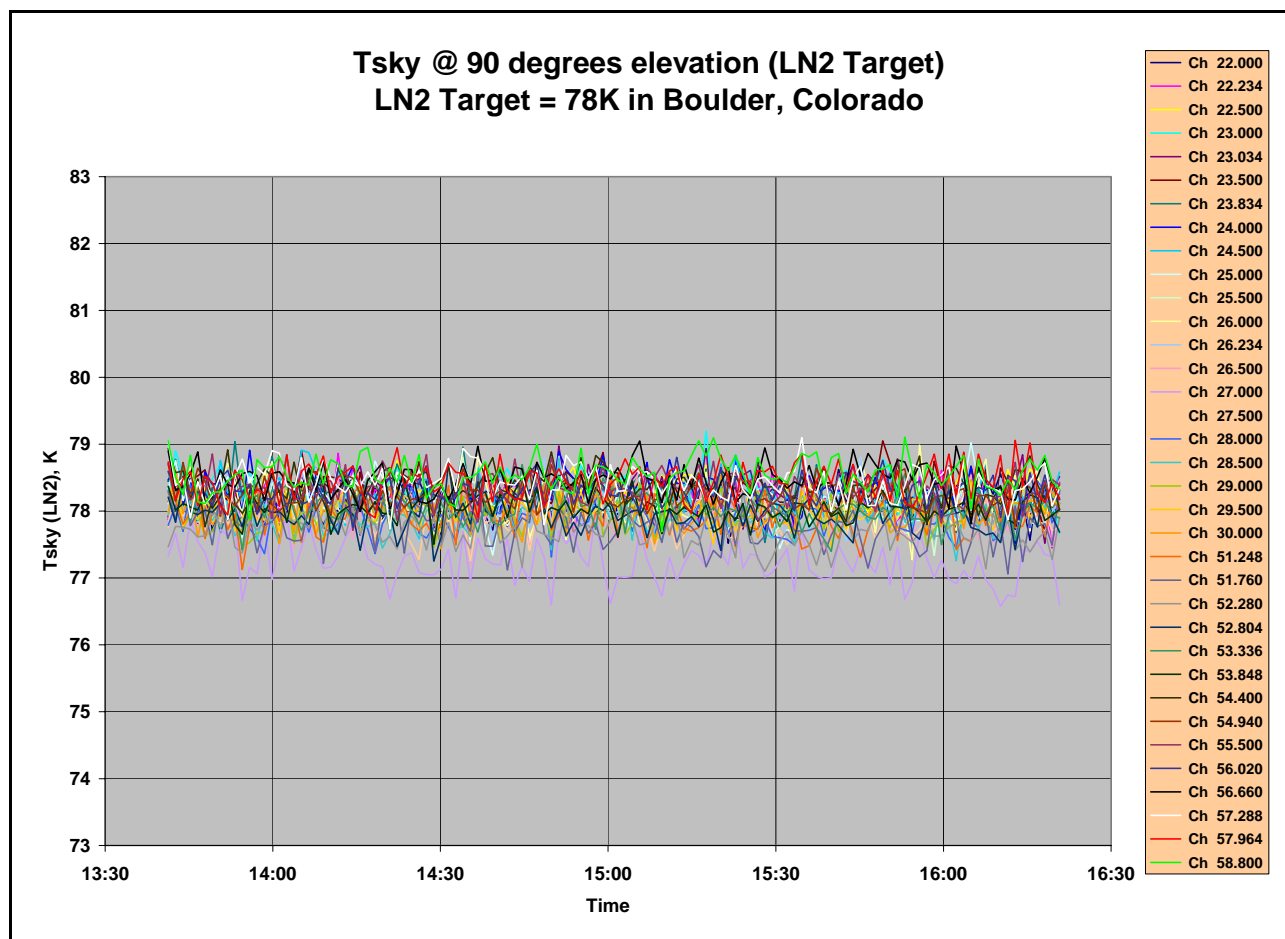

Figure 24 Example of B&L Cryogenic Target temperatures for MP-3000A

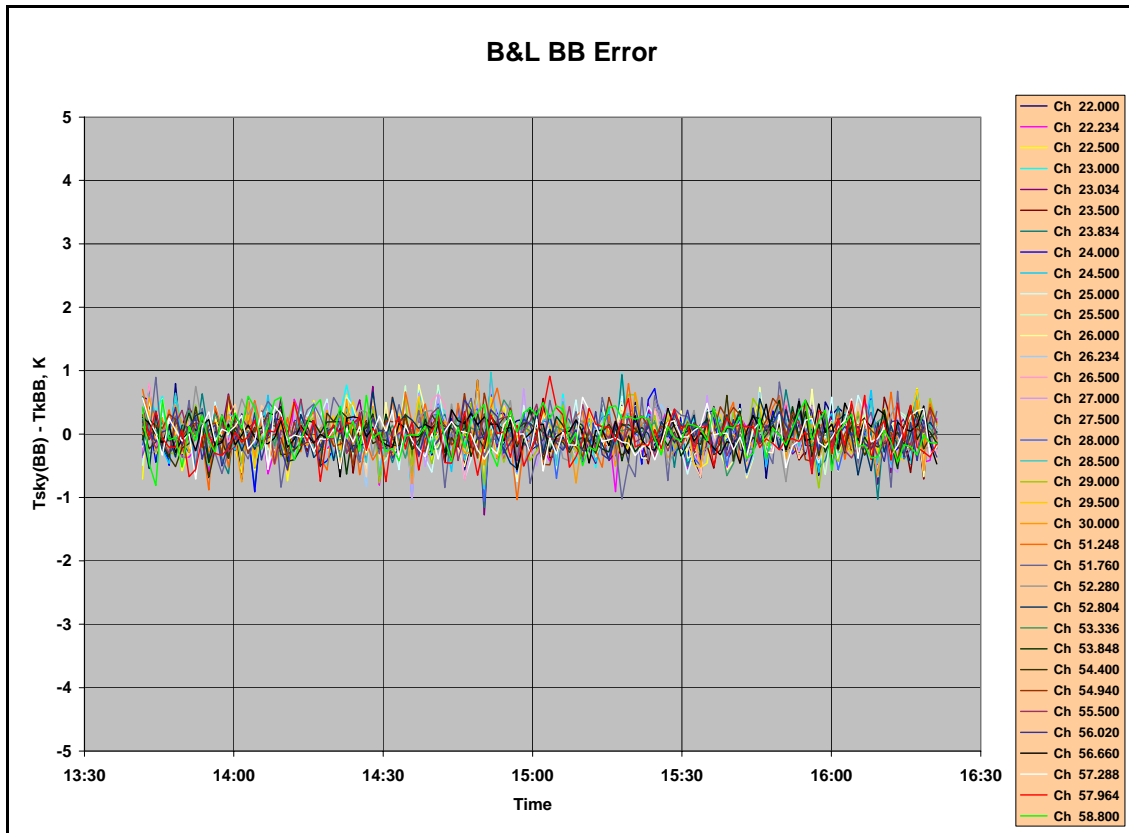

Figure 25 Example of B&L ambient target temperature error for MP-3000A

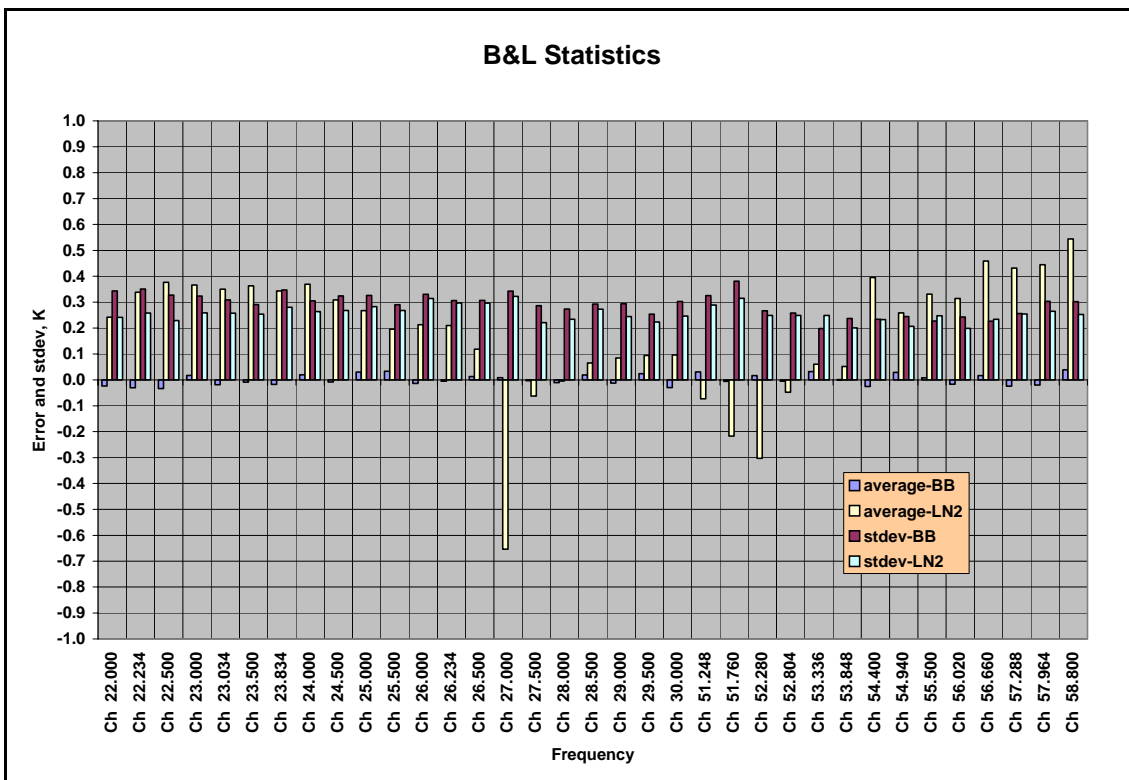

Figure 26 Example of B&L statistics for MP-3000A

5.2 TIP Calibrations

The use of an external Cryogenic Target is required to calibrate the Noise Diodes in 51-59 GHz and 170-183 GHz receivers. The LN2 calibration process described above also calibrates the Noise Diode in the 22-30 GHz receiver. However, because the zenith brightness temperature in the 22-30 GHz band are typically less than 50 K under clear skies, the 22-30 GHz receiver Noise Diode can also be calibrated using a “TIP derived calibration”. In this method, the Profiling Radiometer uses the atmosphere itself as a “cold target”. By observing the brightness temperature of the sky at several elevation angles in rapid succession, the Profiling Radiometer can calculate an estimate of the 22-30 GHz Noise Diode temperatures. The 51-59 and 170-183 GHz Noise Diodes cannot be reliably calibrated using the TIP method due to the relatively small temperature difference observed between the built-in ambient Black Body target and some of the more opaque channels.

5.2.1 LN2 vs. TIP Calibrations: Strengths and Weaknesses

The LN2 and TIP calibration methods each have their own strengths and weaknesses. The following example will illustrate why the LN2 calibration method works best for the 51-59 GHz band, while the TIP method has certain advantages in the 22-30 GHz band.

Assume for the purpose of this cryogenic calibration example that the ambient Black Body target is at 278 K, and there is no ambient target error. Then assume a cryogenic LN2 target at 78 K, but with a 2 K error. This effective LN2 target temperature error will produce a sky brightness temperature with a 1% gain error [$2/(278-78)$]. This manifests as a 2 K error for $T_{sky} = 78$ K, a 1 K error for $T_{sky} = 178$ K, but only 0.2 K error for $T_{sky} = 258$ K. Since most 51-59 GHz channels produce sky brightness temperatures much closer to ambient than the Cryogenic Target (78 K), a relatively large target error does not impact the 51-59 GHz channels as much as it would a 22-30 GHz channel, where the sky brightness temperature is sometimes less than 10 K. Thus, for a given effective LN2 target temperature error, the impact is generally much less in the 51-59 GHz channels than it is in the 22-30 GHz channels. Fortunately, the TIP calibration method works best on the coldest radiometer channels, where the Cryogenic Target is weakest, and the Cryogenic Target works best for the warmest channels, where the TIP method breaks down.

Of course, the TIP calibration method also has error sources, but for 22-30 GHz, these errors can be managed to a level lower than the typical Cryogenic Target induced error. To obtain a high quality TIP calibration, make sure the Profiling Radiometer is level, and use a spreadsheet to select only data from observation periods when the atmosphere is very stable. This process will be described in detail in Section 5.2.2.

5.2.2 TIP Calibration Procedure

To calibrate the 22-30 GHz channels with the TIP method, use the following procedure:

1. Specify the elevation angles to be used in the TIP Configuration section of the configuration file (mp.cfg), if necessary. The default values (30, 45, 90, 135, 150 degrees) usually provide excellent results. In most cases, the use of complementary

angles (i.e., 30 and 150) will provide the best results since they tend to compensate for instrument leveling error and atmospheric gradients.

2. Collect TIP data for at least a few hours during a time when the atmosphere is generally stable. A full day or more may be necessary at times and in areas where the atmosphere is rarely stable. If necessary, collect TIP data for several days to make sure a stable period is included. Select a Procedure File that includes frequent periodic **cal21** commands. The **cal21** command collects TIP calibrations on all 21 K band channels. The standard Procedure File xxx_zen_ret_tip.prc (where xxx is the site code) will produce alternating TIP calibrations, zenith observations and 26 input zenith NN retrievals. New TIP data and the current operational values of Tnd can be viewed graphically in real-time by pressing the T key to check for differences.
3. Open the *TIP* data file (yyyy-mm-dd_hh-mm-ss_tip.csv) in Excel, or a similar data analysis application with graphing capability. Graph the values of Tnd for all 21 channels as a function of time. See Figure 27 for an example. Inspect the graph and select a period when all 21 channels have minimal atmospherically induced noise and maximum stability (no slope). Note a stable time period of several hours or more.

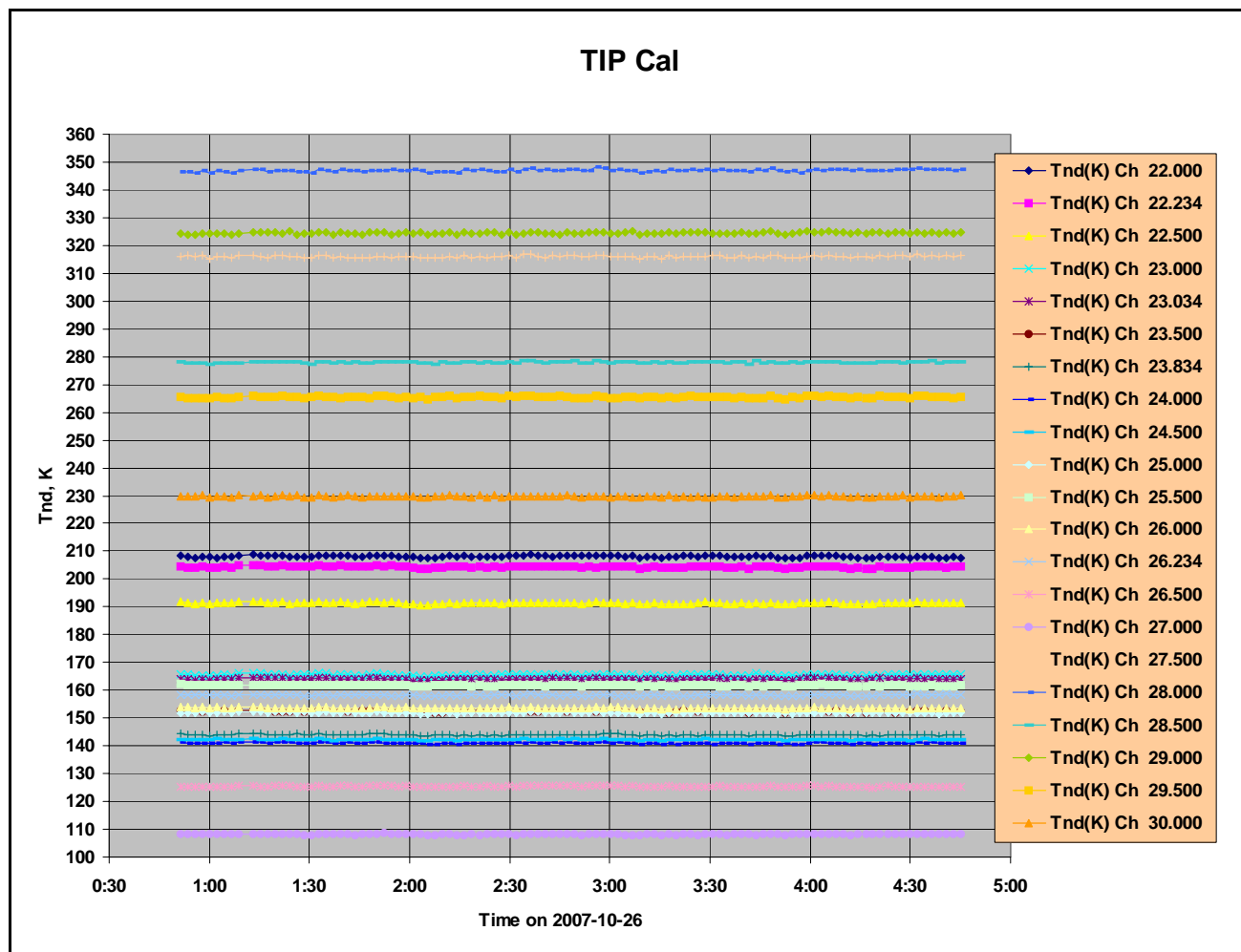

Figure 27 Example of *TIP* data plotted as a function of time.

- Once a stable period of observations has been determined from the time series, compute the average values of Tnd for each channel for that period. See Figure 28 for an example of processed a TIP data file displayed in Excel. In this example, only the first and last few observation records are displayed (records 25-124 are hidden for clarity), and only the first 12 of 21 channels are displayed. Highlighted cells are computed values. The standard Excel “average()” function is used to calculate the average of a range of data in each of the 21 columns of Noise Diode Temperature (Tnd). The average value of Tnd for each channel is copied to the column “Tnd-TIP” for comparison to the current operational values of Tnd, which are always recorded in the header of the tip.csv file for easy reference. The next column, deltaTnd, is computed to find the difference, expressed as a percent, between the current operating values of Tnd and the Tnd values determined from TIPs. In this example, the TIP derived values of Tnd agree very closely with the current values in use (which were derived with a LN2 user calibration), so there is no need to change the operational values.

Record	Date/Time	10	Freq	Rcvr	Alpha	dTdg	K1	K2	K3	K4	Tnd	Tnd-TIP	deltaTnd (LN2-TIP)		
1	10/26/2007 0:49	11	22.000	0	0.9962	-378333	2.21E+02	-2.35E+00	8.23E-03	-9.44E-06	207.740	208.143	-0.19%		
2	10/26/2007 0:49	11	22.234	0	0.9955	-338965	2.17E+02	-2.27E+00	7.91E-03	-9.19E-06	204.330	204.376	-0.02%		
3	10/26/2007 0:49	11	22.500	0	0.9941	-363201	8.21E+01	-1.01E+00	3.93E-03	-4.93E-06	191.390	191.370	0.01%		
4	10/26/2007 0:49	11	23.000	0	0.9906	-365338	1.61E+02	-1.76E+00	6.33E-03	-7.52E-06	165.590	165.608	-0.01%		
5	10/26/2007 0:49	11	23.034	0	0.9913	-374305	1.45E+02	-1.58E+00	5.63E-03	-6.59E-06	164.120	164.015	0.06%		
6	10/26/2007 0:49	11	23.500	0	0.9957	-448631	-5.84E+01	5.96E-01	-2.01E-03	2.24E-06	152.360	152.316	0.03%		
7	10/26/2007 0:49	11	23.834	0	0.9941	-327088	1.50E+00	2.96E-02	-2.45E-04	4.33E-07	143.600	143.984	-0.27%		
8	10/26/2007 0:49	11	24.000	0	0.9943	-337626	3.41E+01	-4.03E-01	1.56E-03	-1.98E-06	140.970	140.982	-0.01%		
9	10/26/2007 0:49	11	24.500	0	0.9947	-375843	1.03E+02	-1.09E+00	3.84E-03	-4.50E-06	142.160	142.227	-0.05%		
10	10/26/2007 0:49	11	25.000	0	0.9938	-376416	6.68E+01	-6.77E-01	2.31E-03	-2.67E-06	151.500	151.879	-0.25%		
11	10/26/2007 0:49	11	25.500	0	0.9937	-359917	1.53E+02	-1.53E+00	5.23E-03	-6.05E-06	161.070	161.731	-0.41%		
12	10/26/2007 0:49	11	26.000	0	0.9944	-502846	1.58E+02	-1.59E+00	5.51E-03	-6.54E-06	153.130	153.617	-0.32%		
13	10/26/2007 0:49	11	26.234	0	0.9961	-485410	1.17E+02	-1.12E+00	3.82E-03	-4.67E-06	157.570	158.217	-0.41%		
14	10/26/2007 0:49	11	26.500	0	0.9957	-455262	6.07E+00	-1.52E-01	7.68E-04	-1.09E-06	125.000	125.410	-0.33%		
15	10/26/2007 0:49	11	27.000	0	0.9973	-571139	-2.20E+02	2.30E+00	-8.05E-03	9.47E-06	108.240	108.204	0.03%		
16	10/26/2007 0:49	11	27.500	0	0.9976	-625081	-3.08E+02	2.92E+00	-9.56E-03	1.09E-05	315.860	315.986	-0.04%		
17	10/26/2007 0:49	11	28.000	0	0.9984	-609425	-2.52E+02	2.33E+00	-7.88E-03	9.04E-06	346.410	346.964	-0.16%		
18	10/26/2007 0:49	11	28.500	0	0.9973	-623955	7.94E+00	-3.99E-01	1.93E-03	-2.25E-06	277.600	277.930	-0.12%		
19	10/26/2007 0:49	11	29.000	0	0.9958	-620806	2.05E+02	-2.45E+00	9.02E-03	-1.04E-05	324.140	324.434	-0.09%		
20	10/26/2007 0:49	11	29.500	0	0.9960	-635232	-2.54E+02	2.49E+00	-8.52E-03	1.03E-05	265.500	265.452	0.02%		
21	10/26/2007 0:49	11	30.000	0	0.9960	-674979	-2.64E+02	2.64E+00	-9.10E-03	1.09E-05	229.690	229.739	-0.02%		
Record	Date/Time	30	TkBB(K)	Tnd(K) Ch 22.000	Tnd(K) Ch 22.234	Tnd(K) Ch 22.500	Tnd(K) Ch 23.000	Tnd(K) Ch 23.034	Tnd(K) Ch 23.500	Tnd(K) Ch 23.834	Tnd(K) Ch 24.000	Tnd(K) Ch 24.500	Tnd(K) Ch 25.000	Tnd(K) Ch 25.500	Tnd(K) Ch 26.000
22	10/26/2007 0:51	31	307.995	208.647	204.585	191.791	165.790	164.150	152.573	144.438	141.237	142.342	152.023	162.198	154.153
23	10/26/2007 0:53	31	307.560	208.067	204.186	191.388	165.545	163.903	152.263	144.078	141.077	142.204	151.708	162.006	153.946
24	10/26/2007 0:55	31	307.177	207.649	204.198	190.873	165.429	163.680	152.182	144.020	140.771	142.136	151.902	162.044	153.576
125	10/26/2007 4:38	31	299.329	207.704	204.318	191.311	165.566	163.960	152.399	143.736	140.955	142.075	151.523	161.499	153.504
126	10/26/2007 4:40	31	299.168	207.671	204.292	191.611	165.550	164.122	152.547	143.907	141.059	142.368	151.915	161.480	153.651
127	10/26/2007 4:42	31	299.002	207.942	204.493	191.527	165.892	164.156	152.236	144.106	141.063	142.285	151.776	161.562	153.355
128	10/26/2007 4:45	31	298.849	207.737	204.400	191.410	165.734	164.109	152.459	143.905	140.959	142.239	151.935	161.757	153.577
			average=	208.143	204.376	191.370	165.608	164.015	152.316	143.984	140.982	142.227	151.879	161.731	153.617

Figure 28 Example of a processed TIP data file displayed in Excel

- To make the new TIP derived values of Tnd the operational values, open the configuration file (mp.cfg) using Notepad and manually replace the existing Tnd values with the new values, then save the file. Refer to Figure 20 and Figure 37 for the location of these values (last column in channel calibration block).

Note: Be sure to open mp.cfg using only **Notepad**, and not a word processor application like MS Word or WordPad. These applications can corrupt the mp.cfg file.

5.3 Surface Met Sensor Calibration

The Surface Met Sensors include ambient air temperature, relative humidity, barometric pressure, IRT (optional), and rain. All Profiling Radiometers are delivered with the Met Sensors pre-calibrated at the factory, ready to use. This Section provides general information about the Met Sensors. For detailed information on the maintenance and calibration of these sensors, refer to Section 7.1

5.3.1 Rotronic S3 Temperature and Relative Humidity Sensor

Radiometrics Profiling Radiometers manufactured after March 2004 are fitted with a new Rain Mitigation System consisting of the SuperBlower and the hydrophobic radome. The SuperBlower uses increased airflow, but no heater (as used in previous models) to keep the radome dry.³¹ The SuperBlower incorporates a [Rotronic S3](#) ambient air temperature and RH sensor in the air-inlet where unbiased ambient air is constantly flowing over the sensor. The SuperBlower assembly also shades the S3 sensor from direct sun. The sunshade and continuous airflow ensure negligible bias due to solar radiation.



Figure 29 SuperBlower with End Cover removed; S3 sensor and filter.

The Rotronic S3 sensor is factory calibrated to a high standard, and normally requires no field calibration. If the user has access to very high accuracy field standards for Tamb and RH, and wishes to adjust the S3 calibrations in the field, linear offset values may be entered in the configuration file (mp.cfg) in place of the default values (0.0) as follows:

```
+0.00      :Tamb correction
+0.00      :Rh correction
```

Offset values for Tamb and RH are *added* to the measured values. For example, if the temperature observed with a high quality standard (placed close to the inlet of the blower) is 0.2K higher than the air temperature recorded by the Profiling Radiometer, then an offset of +0.2 should be entered in the field provided for the Tamb offset in the mp.cfg file. Because the expected difference is normally very small, it may be necessary to average the data for 1-2 hours to obtain a meaningful estimate of the bias.

³¹ Elimination of the heater eliminates one source of locally generated error in ambient temperature and RH measurements.

5.3.2 Barometric Pressure

Barometric pressure is measured with a solid-state transducer located inside the radiometer cabinet. The standard sensor provides the best performance for instruments that will be operated below ~1650 m altitude (pressure > 800 mb). An optional sensor may be fitted for high altitude operations (600-1060 mb). Either sensor can be adjusted with an offset value entered in the mp.cfg file.

5.3.2.1 Standard 800-1060 mb Sensor

The standard pressure sensor is a [Vaisala model PMB100](#). It is a field replaceable, plug-in module that is located on the Master Control Module (MCM) under a small metal housing as shown in Figure 30. The metal housing provides sensor thermal control.

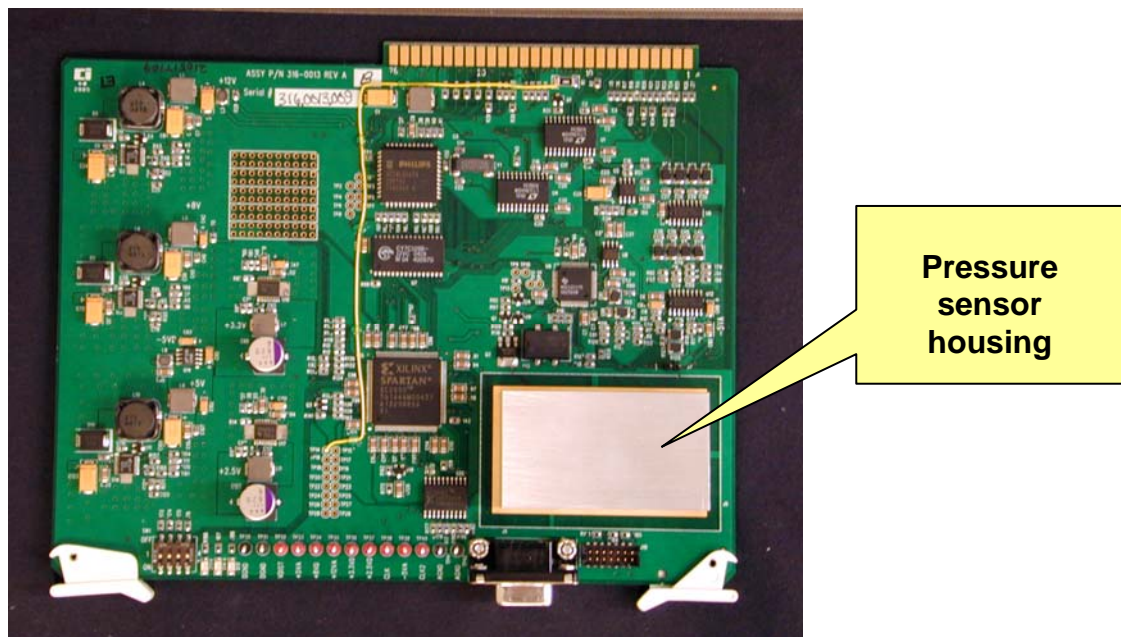

Figure 30 Location of Standard Pressure Sensor on MCM

There are no user adjustable controls on the sensor. However, if the sensor becomes defective, or requires recalibration by the factory, it can be easily changed. To remove the pressure sensor, locate the 4 screws on the back side of the MCM that secure the housing. Remove these 4 screws to access the sensor. The sensor can be removed by gently pulling upward while holding the MCM down on a flat surface. If replacement is required, be sure to line up all the sensor pins with the headers on the MCM before mating. Use standard procedures to prevent static damage.

5.3.2.2 Optional 600-1060 mb Sensor for high altitude

If operation above ~1650 m is required, the optional 600-1060 mb pressure sensor should be fitted. This sensor is a [Vaisala model PTB101B](#), mounted on the side of the radiometer frame. The sensor is connected to the Interconnect PCB with 4 wires as shown in Figure 31.

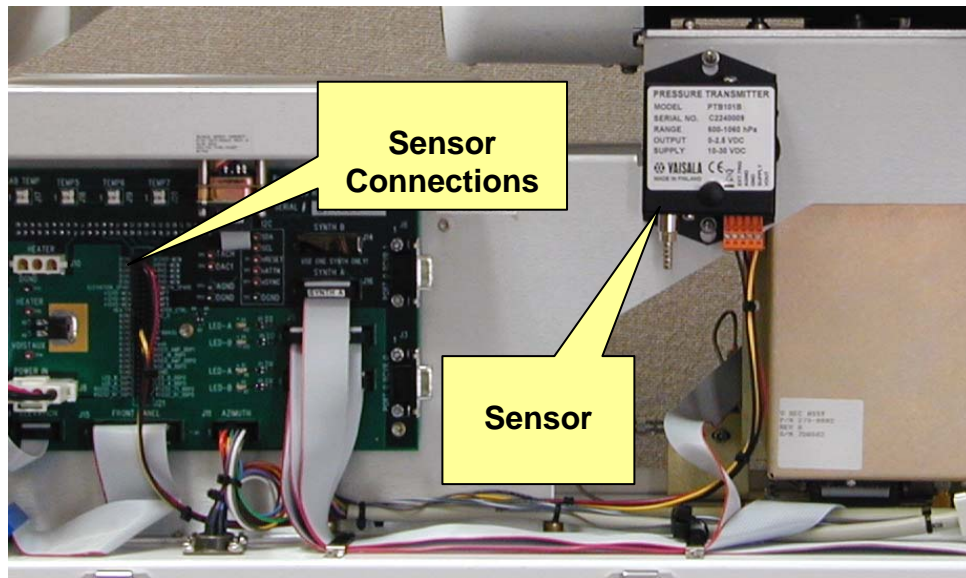

Figure 31 Optional PTB101B Pressure Sensor

5.3.3 Rain Sensor

The Rain Sensor is an analog device that measures conductivity across a grid of inter-digital, gold plated conductors etched on a conventional fiberglass circuit board. The analog output from the device varies approximately as shown in Figure 32.

Rain Sensor Transfer Function

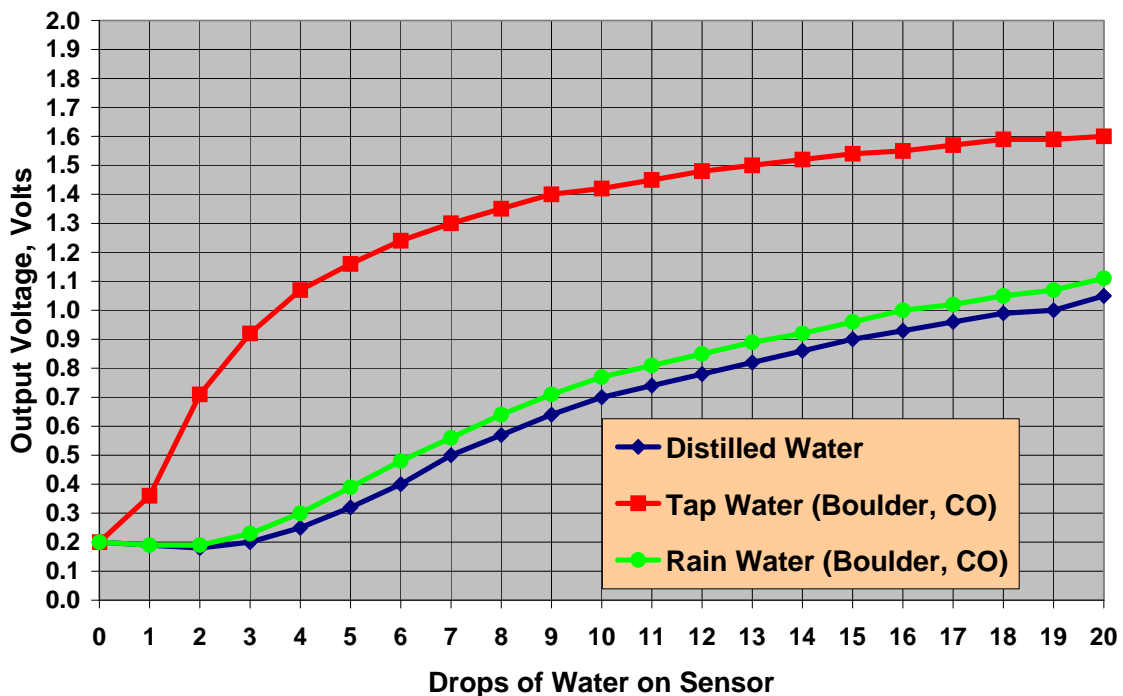

Figure 32 Typical Rain Sensor transfer function

This sensor is used to provide a “Flag” for data that is potentially contaminated by some liquid water on the radome. It is not intended to provide rain rate or total rainfall information. A typical threshold setting of 0.8 volts, specified in the configuration file, is used to “turn on” the Rain Flag (1 or 0) in the *level1* and *level2* data files. The Flag is also displayed on the Profile Graphs. The Flag can also be used to suppress TIP calibrations during rain (specified in *mp.cfg*). To observe the Rain Flag in *level1* data, the Profiling Radiometer must be executing a Procedure File containing **obs** commands.

Precise calibration of the rain sensor is not necessary. The basic function can be verified by dripping a few drops of water on the sensor. When $V_{rain} > \text{Rain Threshold}$ (set in the configuration file), the *level1* Rain Flag = “1”. Wiping the sensor dry should once again set the Rain Flag to “0”. The threshold may be adjusted by opening the configuration file in Notepad and editing the threshold value in the TIP Configuration section. Depending on the sensitivity desired and mineral content of the rain, values between ~0.6 and 1.2 volts can be used. In Figure 32, the difference between distilled water and domestic “tap water” illustrates how mineral content affects the sensitivity.

The Rain Sensor should be wiped clean with a non-abrasive cloth or paper towel as required to keep dirt and mineral deposits from accumulating.

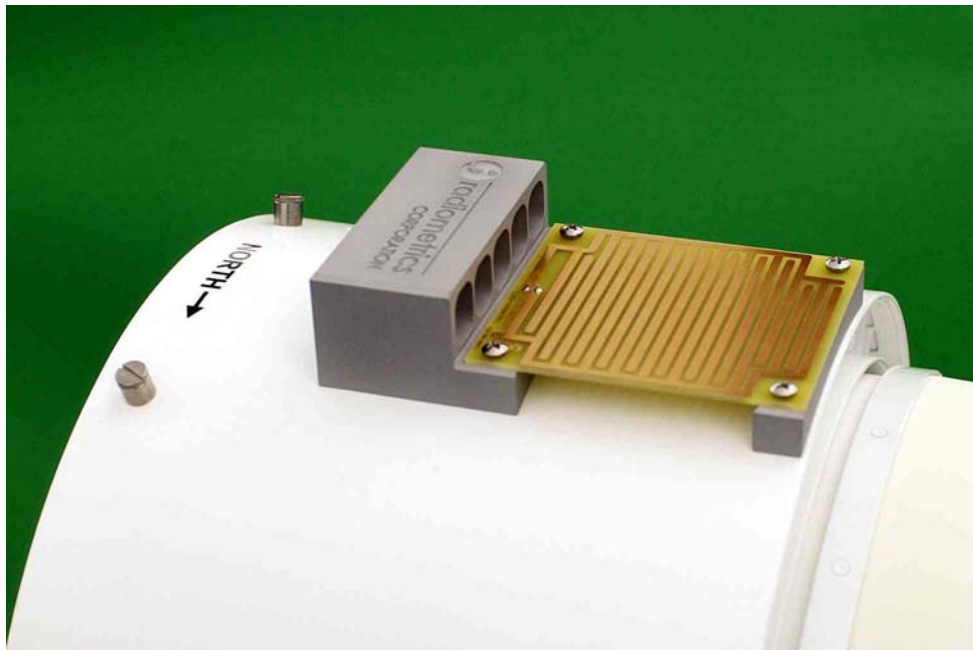

Figure 33 Rain Sensor

5.3.4 Optional Infrared Thermometer

When the optional KT-15 IRT is installed, it is mounted inside the cabinet, positioned to view the sky through a low-loss window in the Cabinet Hood. The IRT is connected to the MCM via the Interconnect PCB. Communication with the MCM is digital (RS232). The IRT is factory calibrated and normally requires no user calibration.

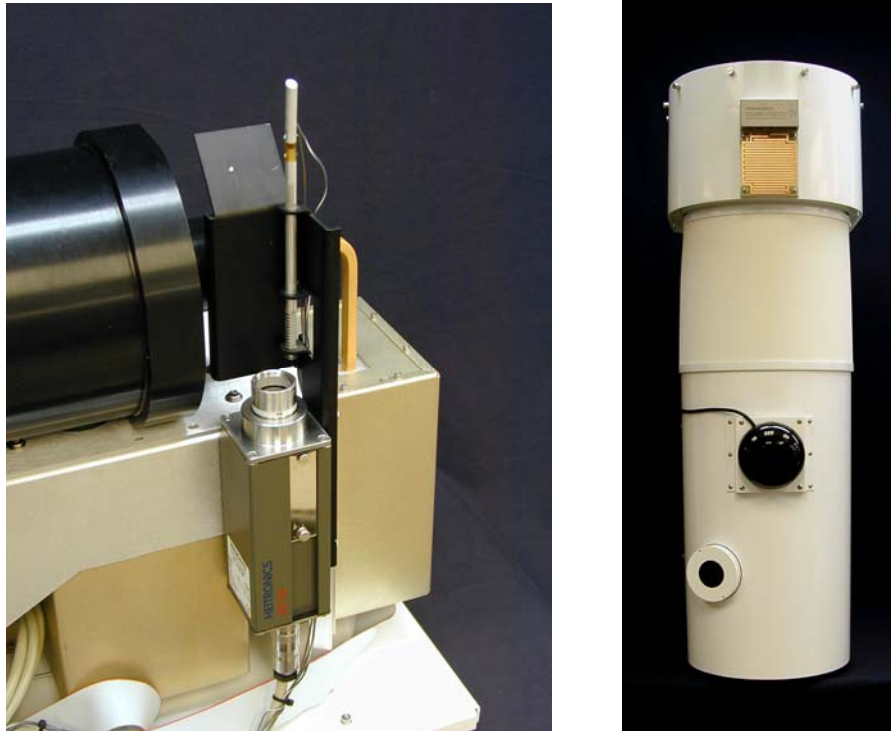

Figure 34 Left: KT-15 IRT Assembly; Right: Top view of Cabinet with IRT Window

Moving the IRT inside the radiometer cabinet has several major advantages over externally mounted IRTs. Mounted inside, the KT-15 instrument is maintained in a moisture free environment, thus eliminating corrosion damage to the lens and mirror sometimes experienced on earlier radiometer models. In addition, the minimum operating temperature is extended to -40°C without the need for supplementary heaters. The new digital interface provides a wider dynamic range and lower noise. The carbon-coated window has a longer life than gold plated mirrors, and is easily field-replaceable by simply unscrewing the old window and screwing on a new one.

To correct for the window loss and reflection errors, the IRT assembly includes two temperature sensors. One measures the window physical temperature, and the other is used to measure the temperature of a black body radiator positioned in the reflection path. The IRT computes the true cloud base temperature using these physical temperatures and factory-calibrated coefficients stored in the mp.cfg file.

6 Configuration, Control, and Data Processing

This section provides detailed information on the configuration and operation of the Profiling Radiometer. It builds on the definitions, procedures, and information introduced in Section 4 and Section 5. Users unfamiliar with the Operator Interface and basic commands should review those sections before proceeding with Section 6. In this section, the user will learn more about the Modes of Operation, Input Files used to configure and control the Profiling Radiometer, and Output files generated by the Profiling Radiometer.

Note: The optional VizMet-B software adds a powerful combination of web server and JAVA based GUI technology. When installed, many of the procedures described herein are simplified or completely automated. Refer to the *VizMet-B User Guide* for information about the operation of the radiometer if VizMet-B has been installed. VizMet-B op-server is a high level supervisory program that runs the operating code for the user via a web based GUI. If VizMet-B software has been installed, but the user desires to control the operating code manually, VizMet-B op-server and certain Windows scheduled tasks must be disabled first. Refer to the *VizMet-B User Guide* for detailed instruction to disable VizMet-B.

6.1 Modes of Operation

The Profiling Radiometers can be operated in either of two modes: **Manual Mode** and **Scheduled Mode**. Operated in Manual Mode, the Operating Code will continue to operate indefinitely until the manually selected Procedure File in use reaches the end of the procedure, or the user terminates operation with a **Q** command. In Scheduled Mode, the Operating Code starts automatically according to the Windows Task Schedule, using a procedure specified in the schedule. In this case, operation continues as scheduled until terminated by the operator. Procedures are ASCII text files that contain a list of commands as described in detail in Section 6.2.2.

6.1.1 Operating in Manual Mode

The Manual Mode of operation is typically used for testing new user defined procedures, short-term data collection and LN2 user calibrations. To start the Profiling Radiometer in Manual Mode, double click on the Radiometer Shortcut Icon on the Desktop display.³² This starts the Operating Code, after which the user may select from the five options listed in Figure 15. Use of Options 1, 2, 3, and 5 was described in Section 4. Option 4 is available during Manual Mode to annotate the *level0* data file produced by the next procedure run. To add a free-form text notation to the next level0 file, press **4**. To complete the entry of each line of text, press the **ESC** key once. The line entered will disappear from the screen, but it will be added to the level0 file. Any number of lines can be entered, each terminated by **ESC**. When the last line has been entered, press **ESC** twice to end the text input, and return to the Main Menu. Then select either option 1, 2 or 3 to proceed.

³² If the Radiometer Shortcut is missing from the Desktop, locate the Operating Code file (mp.exe or similar) in the Operating Directory and make a new Shortcut for the Desktop.

6.1.2 Operating in Scheduled Mode

The Scheduled Mode of operation is normally used for operational or continuous use.

This mode of operation uses the Windows Task Scheduler. To schedule a procedure to be run every day at 00:00 UTC, set the control computer clock to GMT/UTC (no daylight savings), then proceed to schedule the Profiling Radiometer as follows:

1. Open the Windows Control Panel “Scheduled Tasks”. Figure 35 shows how to locate this Control Panel in Windows 2000. Windows XP is similar.
2. Select “Add Scheduled Task” and follow the instructions in the “Task Wizard” to set up a new schedule. Refer to Figure 36 for examples of the dialog. Browse to the Operating Code file (mp.exe or similar) in the operating folder and select it to be the scheduled task. Specify that the task should be performed daily with a start time of 12:00AM. The start day can be any day prior to the current date. Enter the user name and password.³³ Check the box “Open Advanced Properties...”. Click “Finish” to complete the basic schedule.

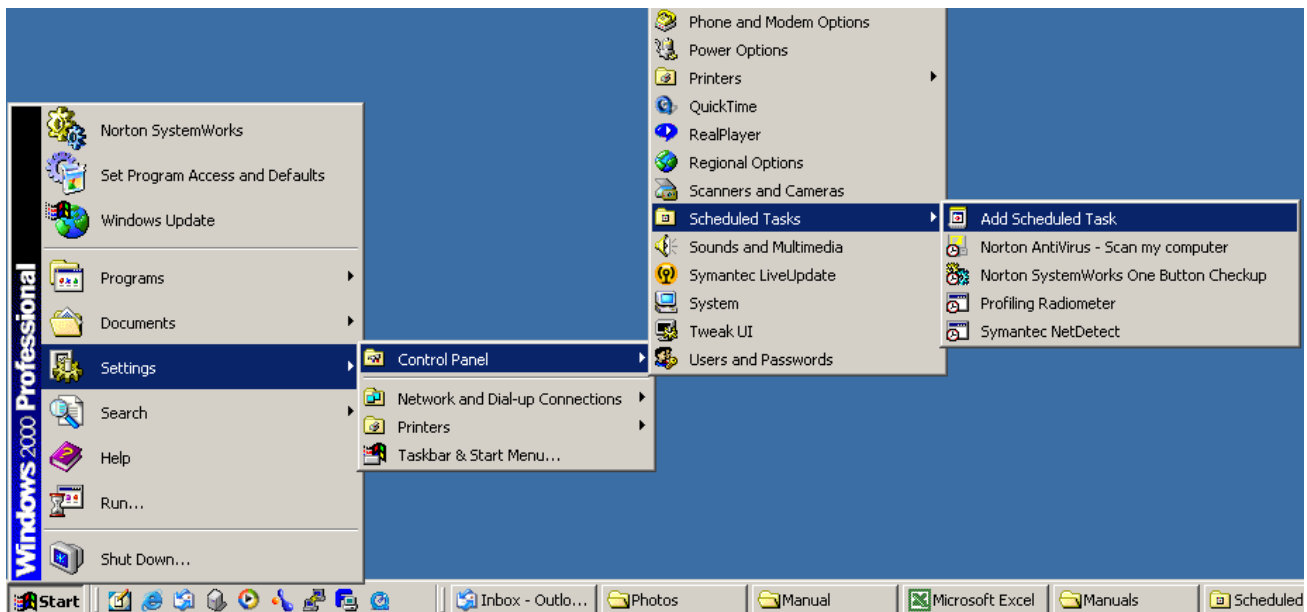

Figure 35 Navigating to Windows Scheduler

3. When the properties window opens, click on the Task tab at the top. In the “Run” box, append a run command (“-r”) and the file name of the procedure to be used, as follows:

[path\mp.exe] -r [filename.prc]

...where filename is the Procedure File to be used.³⁴

³³ Computers supplied by Radiometrics are usually shipped with the default user name and password “laptop” and “laptop”.

³⁴ Some versions of Windows XP require quotation marks before and after the executable path\file name.

Note that one space is required between the path and the command, and another space is required between the command and the filename. The Procedure Filename must include the extension **.prc**.

4. In the “Start in” box, verify that the path points to the Operating Folder. If the mp.exe file was not located in the Operating Folder when the Wizard was used to set up the task, the path will need to be changed to point to the Operating Folder.
5. Select the Schedule tab and verify the schedule. If not correct, edit the schedule as required for daily operation, starting at 12:00AM (00:00 UTC).
6. Select the Settings tab. Un-check all boxes and close the window.

This completes the process to set up a 24-hour schedule to run the Operating Code with a specified Procedure File. To start the schedule immediately, right-click on the schedule icon in the Scheduled Task Folder (lower right screen shot in Figure 36) and select **run**. This will start execution of the Operating Code immediately. Thereafter, it will restart automatically every day at 00:00 UTC.

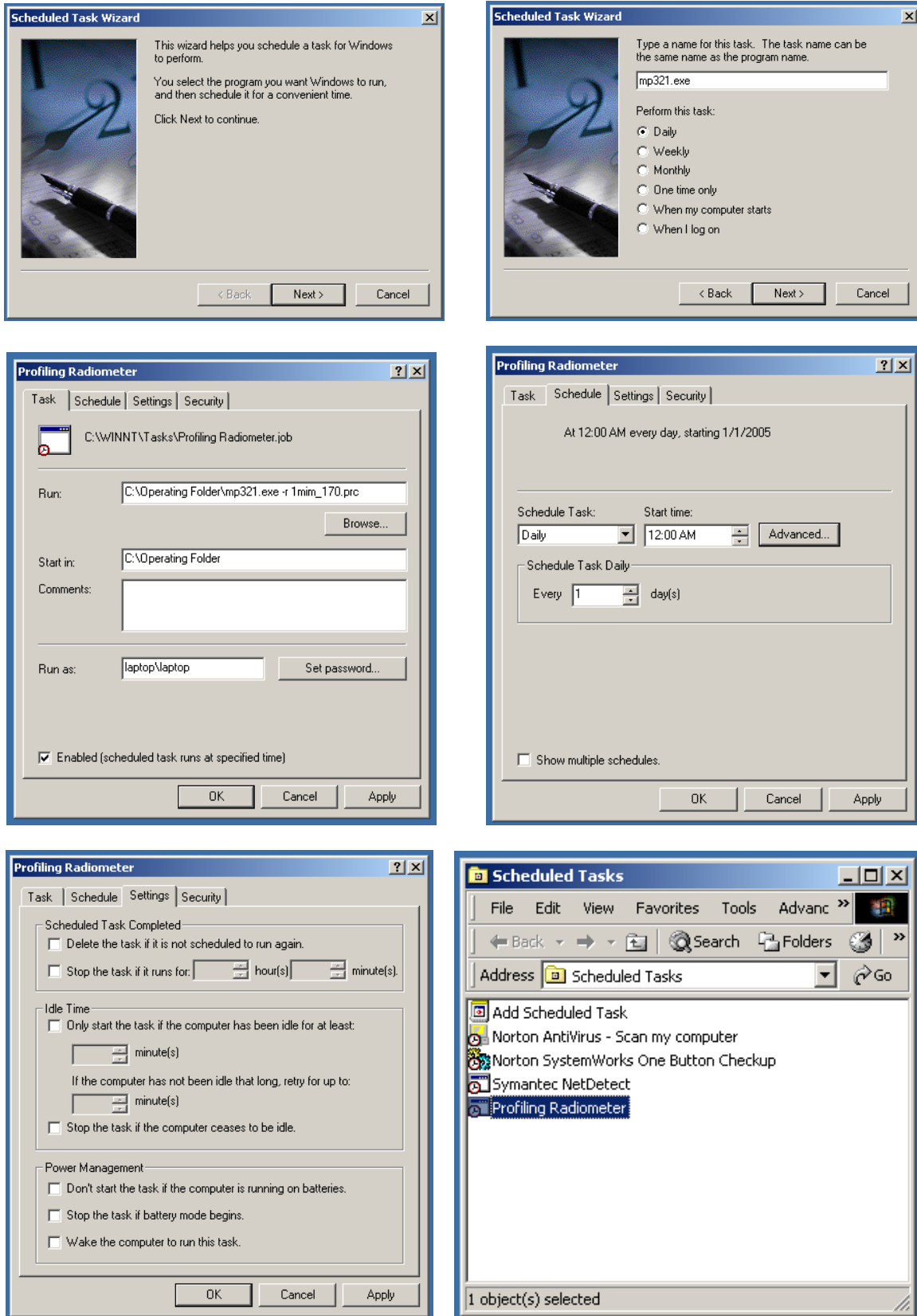

Figure 36 Screen Shots of the Task Scheduling Procedure

6.2 Input Files

There are four types of input files used by the Profiling Radiometer:

- **1 Configuration File**
- **1 or more Procedure Files**
- **Macro Files (optional)**
- **Neural Network Files (optional)**

These files are used by the Operating Code to configure the system, schedule observations, and convert raw data to higher level products. All the programmable features and options available in Profiling Radiometer are specified by the user through these files.

6.2.1 Configuration File

The configuration file contains all the static parameters needed to specify how the Profiling Radiometer will operate, and the calibration information necessary to convert *level0* data to *level1* observations. Figure 37 illustrates a typical configuration file³⁵. The configuration file may be edited in Notepad to change the configuration. Care should be exercised not to inadvertently change any parameter unintentionally. In particular, care should be taken to save changes to the file in plain text format only (no formatting).

The configuration information is grouped in logical blocks with block headers for each highlighted in red in this manual. Generally, parameters are specified in the first field of each line, with comments following a colon delimiter. The use of each field is explained below.

In the MP TYPE block, the specific model and serial number are specified. These fields are specified by the factory and used by the Operating Code to determine what features are enabled for the specific instrument. The Serial Number specified appears in the real-time displays to distinguish different instruments under the control of one computer. The COM port used by the controlling computer is specified on the next line. The COM port specified must be in the range 1-9, and correspond to the Windows COM port connected to the Profiling Radiometer. Setting the “debug” parameter to 1 will enable a serial data link traffic log. The log is stored in the operating folder with a file name in this format:

yyyy-mm-dd_hh-mm-ss_ser.txt.

The TIMER block provides the means for the user to start the instrument in Manual Mode and shut down automatically after a specified length of time in minutes.

³⁵ The details of the configuration file format are operating code version dependent. Earlier and later versions of the operating code may differ slightly in the list of configuration parameters and the format.

```

# Radiometrics V5.00 configuration file for MP-3030A
# Configuration File Format: 5.0
# No more comments

MP TYPE:
MP3000A 3030A :Model & Serial Number
9 :Windows com port (1 to 9)
1 :debug (1=on; 0=off)

TIMER:
-1 :auto "Quit" after this many min, -1 means don't shut down

TIP CONFIGURATION: (For all TIP Commands)
0.90 :regression coeff for a good tip
0.0 :Default Azimuth Angle
5 :Number of Elevation Angles
30 :Tip Elevation Angle #1
45 :Tip Elevation Angle #2
90 :Tip Elevation Angle #3
135 :Tip Elevation Angle #4
150 :Tip Elevation Angle #5
0 :No tips when rain sensor on, 1=allow tips w/rain on
0.8 :rain sensor threshold (volts)

SuperBlower SETTINGS:
.8 :fan rain sensor threshold
88 :fan RH threshold
30 :low blower speed, %FS (rain and RH both below threshold)

SYNTHESIZER TYPE:
1 :1 = 11.0-15.0 GHz; 2 = 11.0-15.3 GHz; 3 = VIDA

CHANNEL CALIBRATION BLOCK:
2007/08/24 14:16:15 Date of last factory LN2 calibration
2007/08/20 17:24:23 Date of last user LN2 calibration 2007-07-20_21-13-54_lv0 2007-07-19_00-00-01_tip
10,10.0,2.5,25,200 :ln2 calibration integration parameters
.90 :target tolerance for ln2 cal
35 :number of frequencies
Frequency,Rcvr,MRT,Window Coef,ND drive,IF Atten,alpha,dtDg,k1,k2,k3,k4,Tnd
22.000,0,275.0,.000140,30000,27.0,0.99629,-0.31768991E+06,-0.76431012E+02,0.65480539E+00,-0.18386266E-02,0.16878899E-05,196.81
22.234,0,275.0,.000140,30000,27.0,0.99768,-0.30449086E+06,-0.90020227E+02,0.89065263E+00,-0.29057276E-02,0.31203679E-05,196.56
22.500,0,275.0,.000140,30000,27.0,0.99902,-0.29421473E+06,-0.14331956E+03,0.12794747E+01,-0.37980179E-02,0.37592855E-05,194.83
23.000,0,275.7,.000150,30000,27.0,0.99858,-0.33490370E+06,0.87604179E+02,-0.99541401E+00,0.36259509E-02,-0.42591571E-05,184.79
23.034,0,275.7,.000150,30000,27.0,0.99729,-0.33757981E+06,-0.27335110E+03,0.26732009E+01,-0.87270203E-02,0.95151602E-05,184.15
23.500,0,275.7,.000150,30000,27.0,0.99974,-0.38054902E+06,0.50238971E+02,-0.57614820E+00,0.21847483E-02,-0.27427661E-05,169.05
23.834,0,276.0,.000150,30000,27.0,0.99982,-0.37805543E+06,-0.10218579E+03,0.99328747E+00,-0.32286814E-02,0.35124249E-05,153.40
24.000,0,275.7,.000150,30000,27.0,0.99978,-0.43045085E+06,0.34073505E+01,-0.18660452E+00,0.11058613E-02,-0.17341826E-05,148.95
24.500,0,275.7,.000160,30000,27.0,0.99869,-0.51730185E+06,0.96832603E+02,-0.10456006E+01,0.37213577E-02,-0.43697823E-05,135.77
25.000,0,275.4,.000160,30000,27.0,0.99839,-0.52755821E+06,-0.23157468E+03,0.23923680E+01,-0.81949774E-02,0.93068824E-05,133.90
25.500,0,275.4,.000160,30000,27.0,0.99971,-0.56186543E+06,-0.53188174E+02,0.59801352E+00,-0.21717602E-02,0.25589112E-05,142.62
26.000,0,275.4,.000170,30000,27.0,1.00000,-0.62305803E+06,0.33653767E+02,-0.34761966E+00,0.12553827E-02,-0.15753721E-05,177.61
26.234,0,275.4,.000170,30000,27.0,0.99997,-0.54542448E+06,-0.54542448E+06,0.54090282E+02,-0.59930559E+00,0.22123987E-02,-0.27206687E-05,191.40
26.500,0,275.4,.000170,30000,27.0,0.99971,-0.63394212E+06,-0.84983257E+02,0.79333439E+00,-0.23706647E-02,0.22259701E-05,212.13
27.000,0,275.4,.000170,30000,27.0,0.99889,-0.69451419E+06,0.12437610E+03,-0.13062494E+01,0.46055814E-02,-0.54488979E-05,250.41
27.500,0,275.4,.000180,30000,27.0,0.99949,-0.58482456E+06,0.17589247E+03,-0.18751792E+01,0.66171422E-02,-0.77326727E-05,261.56
28.000,0,275.4,.000180,30000,27.0,0.99970,-0.70658319E+06,0.16086296E+03,-0.17063933E+01,0.60137623E-02,-0.70427774E-05,253.54
28.500,0,274.1,.000180,30000,27.0,0.99920,-0.61559063E+06,0.59606961E+02,-0.65946123E+00,0.23581131E-02,-0.27341032E-05,213.05
29.000,0,274.1,.000180,30000,27.0,0.99927,-0.53176114E+06,-0.57488426E+02,0.53750636E+00,-0.17397318E-02,0.19649443E-05,185.40
29.500,0,274.1,.000190,30000,27.0,1.00032,-0.50430706E+06,-0.31575206E+02,0.29256171E+00,-0.97910474E-03,0.11921366E-05,157.14
30.000,0,274.1,.000190,30000,27.0,0.99865,-0.43434168E+06,-0.62848773E+01,-0.16679112E-01,0.27383302E-03,-0.48823395E-06,134.88
51.248,1,274.1,.000330,40000,17.5,0.98709,-0.77388427E+06,0.15964606E+03,-0.16140337E+01,0.53331377E-02,-0.57441127E-05,181.46
51.760,1,274.1,.000330,40000,17.5,0.99948,-0.57388871E+06,-0.97545914E+02,0.10757578E+01,-0.39239766E-02,0.47391282E-05,156.18
52.280,1,274.1,.000330,40000,17.5,0.99387,-0.47463579E+06,-0.20170151E+02,0.20546433E+00,-0.77045998E-03,0.10406814E-05,129.65
52.804,1,274.1,.000340,40000,17.5,0.98970,-0.43634323E+06,0.61187441E+02,-0.57968865E+00,0.17921096E-02,-0.17956516E-05,123.24
53.336,1,274.1,.000340,40000,17.5,0.99438,-0.42617809E+06,0.83331744E+02,-0.88454499E+00,0.30871757E-02,-0.35444330E-05,132.09
53.848,1,274.1,.000340,40000,17.5,0.99634,-0.41851710E+06,-0.30069663E+02,0.34645502E+00,-0.13388614E-02,0.17301221E-05,131.72
54.400,1,274.1,.000350,40000,17.5,0.99391,-0.40130307E+06,-0.38639795E+02,0.42404495E+00,-0.15559240E-02,0.19074160E-05,115.48
54.940,1,274.1,.000350,40000,17.5,0.99325,-0.33640589E+06,-0.11299733E+03,0.11709588E+01,-0.40703632E-02,0.47454517E-05,99.70
55.020,1,274.1,.000350,40000,17.5,0.99610,-0.32636329E+06,-0.16920353E+03,0.17887438E+01,-0.63058758E-02,0.74128493E-05,96.90
56.020,1,274.1,.000360,40000,17.5,0.99476,-0.36170253E+06,-0.21161303E+03,0.22252500E+01,-0.78235408E-02,0.91947317E-05,100.24
56.660,1,274.1,.000360,40000,17.5,0.99086,-0.34858652E+06,0.68958671E+02,-0.71963264E+00,0.24922216E-02,-0.28644489E-05,106.61
57.288,1,274.1,.000370,40000,17.5,0.99449,-0.33323036E+06,-0.19358290E+03,0.20167851E+01,-0.69983829E-02,0.80888604E-05,110.91
57.964,1,274.1,.000370,40000,17.5,0.99410,-0.41196303E+06,-0.20114621E+03,0.20852541E+01,-0.72537698E-02,0.84654781E-05,121.23
58.800,1,274.1,.000370,40000,17.5,0.99233,-0.37292125E+06,-0.12267874E+03,0.13677062E+01,-0.50190817E-02,0.60744075E-05,125.00

COEF: :Coefficients for LN2 calibration and surface sensors
13.0 :LN2 liq depth in cm
68.23 :LN2 BP C0, the LN2 boiling point linear equation
0.009037 :LN2 BP C1
0.0078 :LN2 interfaces correction
6.08e-6 :LN2 polystyrene dielectric loss coef ~ 1.16e-5 K/K-cm-GHz
5.1 :LN2 Styrofoam thickness [cm]
+600.00,+184.00 :Air press C0,C1 (P=c0+c1*Volts)
+0.00,+0.00 :X-tilt equation c0,c1
+0.00,+0.00 :Y-tilt equation c0,c1
0.05,0.065 :IRT window reflection, absorption

USER CORRECTIONS:
+0.00 :pressure sensor correction
-0.00 :Tamb correction (edit with values for this instrument)
+0.00 :RH correction (edit with values for this instrument)
-1.50 :BB sensor correction (default= -1.50)

GPS:
15 :Cut-off elevation angle
0 :Minimum SNR

```

Figure 37 Configuration File for V5.0 Operating Code (mp.cfg)

The TIP configuration block specifies all parameters used by the TIP calibration algorithm. The regression coefficient is a threshold for data quality checks. It should be adjusted to a value between 0.97 and 0.99 normally. Higher thresholds impose a higher quality standard. The default Azimuth Angle specifies the azimuth for TIP calibrations when the optional Azimuth Positioner is installed. The next line specifies the number of elevation angles the instrument will use for the TIP calibration. This number must match the number of lines below, each specifying a specific elevation angle. In general, it is recommended that the 5 default values specified in the example be used. TIP elevation angles less than 20° may result in some sidelobe contamination. More angles can be used, but the extra time required must be considered. Longer times to complete the TIP can introduce sampling error as the atmosphere changes. In all cases, it is desirable (but not required) to specify TIP angles in complementary pairs (i.e., 045° and 135°, 030° and 150°) so that leveling error and atmospheric gradients tend to be averaged. Following the last angle, a switch is provided to either allow, or not allow TIPs when rain is detected by the rain sensor. The last line in the block specifies the threshold defining when the rain sensor flag is switched as described in Section 5.3.3.

In the SuperBlower Settings block, the user can specify the conditions for the SuperBlower flow rate to be reduced from its maximum rate. The SuperBlower flow will be automatically set to the maximum rate (100%) if the rain sensor voltage exceeds the specified threshold (.8V typical), or the surface RH exceeds the specified threshold (70% typical). If neither condition is met, then the SuperBlower flow will be set to the specified low blower speed value (30% typical). To turn off the SuperBlower, set both thresholds very high (i.e., 2V and 101%) and the low blower speed to 0. To force it on all the time, set the rain or RH threshold to 0. Note that the SuperBlower is always set to 100% while an LN2 user calibration is running.

The Synthesizer Type is set at the factory and should not be changed.

The CHANNEL CALIBRATION BLOCK contains all the factory and user LN2 calibration data. This block is set up at the factory and should not be edited by the user, except to manually transfer a new TIP calibration as discussed in Section 5.2.2.

The COEF block contains all the parameters needed by the Operating Code to compute the effective LN2 target temperature, and for the conversion of *level0* Met Sensor data to *level1*. These values are set at the factory and, except for LN2 depth, should not normally need to be adjusted by the user.

The User Corrections block can be used to *add* an offset adjustment to the ambient pressure, temperature and RH. The factory calibrations for these three sensors are very accurate and do not normally require further adjustment. In general, no offset value should be added unless the user has access to high accuracy standards for calibration of these three sensors.

The GPS block is reserved for future use.

6.2.2 Procedure Files

A Procedure File is a list of high level commands that define a specific series of observations and retrievals to be performed. Two basic types of procedures can be defined: “relative” and “absolute”. Relative procedures are command lists that execute sequentially, with each command beginning immediately following the completion of the previous command. Absolute procedures are command lists in which each command is specified to execute at a specific time of day. Procedure files provide the user with a simple, but powerful way to customize the operation of the instrument for automatic data collection. All Procedure Files are ASCII text files with the extension “.prc” (i.e., *ZenithRet.prc*). Procedure files can be generated using any text editor, such as Notepad. However, long absolute procedures with many repeating commands are more easily generated using a spreadsheet to automatically compute the series of **absolute** command execution times.

6.2.2.1 Procedure Commands

Procedure Commands are the basic building blocks used to create a procedure. There are 10 high level commands available. Each command occupies one line in a Procedure File, starting in the first column of the line, and terminated by a carriage return (**CR**). Commands with required or optional parameters are delimited by one or more spaces, or one tab or one comma character may be used between fields in command lines.

NOTE: All procedure commands must be specified in lower case letters only.

6.2.2.1.1 Antenna Coordinate System

The coordinate system used in all commands to specify the antenna pointing vector is given in Table 4. The elevation angle is defined for the state when az=000° (north). Therefore, if the azimuth is rotated to 180° (south), the antenna will point to the southern horizon when el=000°.

Azimuth (az)		Elevation (for az=000)	
000°	north	000°	north
090°	east	090°	zenith
180°	south	180°	south
270°	west	270°	nadir (BB target)

Table 4 Antenna Coordinate System

NOTE: There are always two az/el specifications that produce the same pointing direction. For example, the direction given by az=000°/el=045° is equivalent to the direction az=180°/el=135°. The Operating Code automatically chooses the coordinates that will reposition the antenna faster, regardless of which way the user specifies the coordinates.

NOTE: The elevation drive resolution is 0.45° (800 steps per revolution). If an angle is specified that is not an even multiple of 0.45°, then the Operating Code rounds the number to the nearest angle available, and the angle actually used is logged in the output files. For example, if the user specifies an elevation angle of 30.00°, the radiometer will use and record 30.15°.

6.2.2.1.2 *relative, absolute and repeat Commands*

The first line in all Procedure Files must contain either the “**relative**” or “**absolute**” command . These commands define whether all the commands that follow are to be executed sequentially, with no delay between commands, or executed at a specified time. With both relative and absolute procedures, the command sequence specified will continue to execute until the operator presses the Control Computer **Q** key to Quit, or the end of the procedure is reached, whichever occurs first. If the command “**repeat xxxxx**” is added as the last command in a relative procedure, then the complete procedure will be repeated xxxxx times before the program terminates, where xxxxx is any positive integer. **Relative, absolute and repeat** commands do not add to the execution time of the procedure.

6.2.2.1.3 *The **trcvcal** Command*

The **trcvcal** command causes the Profiling Radiometer to calibrate the receiver noise temperature for all microwave receivers present. This calibration produces a new value of system temperature for all specified channels, from which a new value of receiver temperature (Trcv-bb) is calculated ($Trcv-bb = T_{sys} - T_{kBB}$) for all specified channels. This value of Trcv-bb is used in the calculation of all real-time *level1* and *level2* data products.

The receiver temperature is very stable over a period of minutes, but will drift slightly with large ambient temperature changes. Thus, **trcvcal** commands should be included periodically in all procedures.

In choosing a **trcvcal** command frequency, several factors should be considered. Very frequent **trcvcal** commands will result in the best theoretical absolute accuracy. But **trcvcal** commands take approximately the same execution time as the **obs** commands. Thus, a **trcvcal** command preceding every sky observation may produce the smallest drift error, but it reduces the available sky observation time. Practical experience suggests one **trcvcal** command every 5 minutes, with many **obs** commands in between, is adequate in nearly all cases.

The command format for the **trcvcal** command is:

hh:mm:ss trcvcal nsec,nint,n0,n1,f01,...,f0n0,f11,f12,...f1n1

...where:

nsec is reserved for future use (set to 0)
nint is the integration time in milliseconds
n0 is the number of RCV0 frequencies to calibrate
n1 is the number of RCV1 frequencies to calibrate
fij is jth frequency in MHz for ith receiver. Must be in order by receiver and frequency.

6.2.2.1.4 The **cal21** Command

The **cal21** command is applicable to the MP-3000A and MP-1500A only. It causes the Profiling Radiometer to collect a set of 22-30 GHz observations at elevation angles specified in the configuration file. From these observations, estimates of the Noise Diode temperatures (Tnd) for all 21 K band channels are derived. These estimates of Tnd are logged to the current yyyy-mm-dd_hh-mm-ss_*tip*.csv file for calibration use as described in Section 5.2.2.

The command format for the **cal21** command is:

hh:mm:ss cal21 az int-time

...where the value **az** = azimuth angle to be used for the **cal21** observations (if the optional Azimuth Positioner is installed), and **int-time** is the integration time in milliseconds for one channel (200 msec typical). Since the TIP Calibration process uses the latest available surface met data and Trcvcal data as input, it is best to precede all **cal21** commands with a **met** command and trcvcal command within the previous 1-2 minutes.

6.2.2.1.5 The **obs** Command

The **obs** command directs the Profiling Radiometer to point the antenna to a specific elevation angle (el), and if the optional Azimuth Positioner is installed, to a specific azimuth angle (az), and then measure the brightness temperature on all specified channels for the specified integration times. If no Azimuth Positioner is installed, a dummy value of az = 000 should be included in the command. The command format for the **obs** command is:

hh:mm:ss obs az,el,nint,n0,n1,f01,...,f0n0,f11,f12,...f1n1

...where:

az is the observation azimuth
el is the observation elevation
nint is the integration time in milliseconds
n0 is the number of calibrated RCV0 frequencies to observe
n1 is the number of calibrated RCV1 frequencies to observe
fij is **jth** frequency in MHz for **ith** receiver. Must be in order by receiver and frequency.

6.2.2.1.6 The **met** Command

The **met** command logs the current surface met sensor data (Tamb, RH, Pressure, IRT temperature (if the optional IRT is fitted) and Rain. There are no parameters. The command format is:

hh:mm:ss met

6.2.2.1.7 The **eng** Command

The **eng** command logs the current values of 48 housekeeping data parameters (aka engineering data) in the level0 file, record type 91. There are no command line parameters. The values logged are as follows:

MCM & Frame Readings		Receiver 0 Readings	
Index	Description	Index	Description
0	V0 / Rain voltage	26	RCV0 TECV
1	V1	27	RCV0 TEC Duty Cycle
2	V2	28	RCV0 Antenna Temperature (T1)
3	TEMP0 / BB0	29	RCV0 TkND (T2)
4	TEMP1 / BB1	30	RCV0 TkIF (T3)
5	TEMP2 / Cabinet	31	RCV0 Case Temperature (T4)
6	TEMP3 / IRT0 - Reflected (BB)	32	RCV0 +8V
7	TEMP4 / IRT1 - Transmitted	33	RCV0 ND On Voltage
8	TEMP5 / Spare	34	RCV0 ND Off Voltage
9	TEMP6 / Spare		
10	TEMP7 / Spare		
		Receiver 1 Readings	
11	Vdist MCM	Index	Description
12	+12VD MCM	35	RCV1 TECV
13	+8VD MCM	36	RCV1 TEC Duty Cycle
14	+5VD MCM	37	RCV1 Antenna Temperature (T1)
15	+3.3VD MCM	38	RCV1 TkND (T2)
16	+2.5VD MCM	39	RCV1 TkIF (T3)
17	-5VD MCM	40	RCV1 Case Temperature (T4)
18	2.5VR MCM	41	RCV1 +8V
19	Pressure Sensor Temp	42	RCV1 ND On Voltage
20	Pressure Sensor Output	43	RCV1 ND Off Voltage
21	Pressure Sensor Reference		
22	Computed Pressure		
		Elevation Readings	
23	S3 Temp	Index	Description
24	S3 Humidity	44	Home Offset
25	IRT Temp	45	East / West Tilt
		46	North / South Tilt
		Other	
		Index	Description
		47	SuperBlower Speed

Table 5 Housekeeping Data Parameters logged by “eng command”

6.2.2.1.8 The **tdp** Command

The **tdp** command logs the current GPS time, date and position in the level0 file, record type 31. Additional data about the current status of the GPS is also included in the type 31 record. The command format is:

hh:mm:ss tdp

There are no command line parameters for the **tdp** command.

6.2.2.1.9 The **mac** Command

mac commands function like subroutines in software codes. They provide the means to create time saving custom user commands consisting of any valid series of standard commands often repeated. Commands within a macro file do not require a time at the beginning of the command line. They are executed like a relative procedure, with no delay between the commands. Valid commands for inclusion in a macro file include all except the **mac** and **repeat** commands. **mac** commands can not be “nested”. The format is:

hh:mm:ss mac macro

...where **macro** is the file name of a macro stored in the macro subdirectory, located in the operating folder.

As an example, suppose a user needs to routinely repeat a sequence of observations at 6 azimuth angles evenly spaced 60 degrees, at an elevation angle of 30 degrees, on 2 K and 2 V band frequencies. The macro file contents might look like this:

```
trcvcal 0,200,2,2,23834,30000,51248,58800
obs 0.0,30.0,200,2,2,23834,30000,51248,58800
obs 0.0,150.0,200,2,2,23834,30000,51248,58800
obs 60.0,30.0,200,2,2,23834,30000,51248,58800
obs 60.0,150.0,200,2,2,23834,30000,51248,58800
obs 120.0,30.0,200,2,2,23834,30000,51248,58800
obs 120.0,150.0,200,2,2,23834,30000,51248,58800
```

Now suppose the macro file is given the name “**mac1**” and the file is stored in the macro subdirectory. With this macro stored, procedures can use the following command to execute all 7 commands listed in the macro:

hh:mm:ss mac mac1

When executed, the **mac1** command will calibrate the receiver temperature on 4 frequencies (22000, 23834, 51248 and 58800 MHz) using 200 msec integration time, then point the antenna to az=0.0; el=30.0 degrees and collect brightness temperatures on the same 4 frequencies using 200 msec integration time, then repeat the observations at the next 5 az/el pointing angles. Because azimuth moves are relatively slow (15 degrees/sec) compared to elevation moves (180 degrees/sec), this macro uses 3 azimuth angles (0, 60 and 120 degrees) and alternating elevation angles (30 and 150 degrees) to save time.

6.2.2.1.10 *The **nnret** Command*

The **nnret** command produces neural network derived level2 data from current level1 data. For the MP-3000A, 5 neural network retrievals are typically provided for each site where the instrument will be used. These include retrievals for profiles of temperature, RH, vapor and liquid plus scalar values of integrated vapor and integrated liquid. The command format is:

hh:mm:ss nnret nnfilename

...where **nnfilename** is the name of a neural net file located in the operating folder.

6.2.2.2 **Relative Procedures**

Relative procedures are generally used when the fastest possible observation cycle time is required, and control over the exact time of the observations is not as important. Relative procedures generally execute more quickly than absolute procedures because there is no wait-state time between commands. To specify that a procedure is a relative procedure, the first line in the procedure file must contain the word “**relative**” followed by a carriage return (**CR**). Subsequent commands in a relative procedure each have dummy time fields with all zeros (00:00:00) followed by the command and parameters, if any.

Relative procedures are also useful to determine the execution times for each of the commands in a sequence of commands that the user desires to execute in an absolute file. The execution time of some commands depends on many variables, some of which cannot be easily predicted. For example, antenna movements from one position to another require different times depending on the specific start and ending angles. Thus, it is not practical to provide exact command sequence execution times for all commands in all cases. However, any user-defined sequence of commands can be timed using a relative procedure. Once the command execution times are known for a given sequence of commands, an absolute procedure can be written to provide sufficient time for the execution of each command, without wasting unnecessary wait-state time between commands.

6.2.2.3 **Absolute Procedures**

Absolute procedures are recommended for most observing plans because they provide uniform observation and calibration timing in the output files, best suited for most operational scenarios. Unlike relative procedures, each command in an absolute procedure is executed at a specific hour, minute and second, specified in the first field of the command (hh:mm:ss). To specify that a procedure is an absolute procedure, the first line in the Procedure File must contain the word “**absolute**” followed by a carriage return (**CR**). Subsequent commands in an absolute procedure each have execution times followed by the command and parameters, if any. The execution times must be sequential, and the time of execution for all commands must be specified to provide sufficient time for the previous command to complete. Commands specified to execute before the completion of the previous command will be skipped.

Absolute procedures can also be programmed to provide different observation and calibration sequences at different times of the day. For example, a procedure could be

written to collect only zenith observations during the day, and TIP calibrations during the night. Or, each hour of the day could be divided into two periods: one set of observations for the first 50 minutes, and different observations for the other 10 minutes of the hour. In this way, the user has complete control over the observation sequence and timing.

6.2.2.4 Procedure Timing

As noted above, command execution times vary, depending on integration time, the previous state of the antenna position, and other factors. To insure that all commands complete before the next is scheduled to execute, a new command sequence can be timed by using a relative procedure. Typical execution times can be determined by examining the *level0* file produced by a relative procedure, noting the times of each command execution. For example, if a given configuration and command sequence results in the **obs** command taking 13-14 seconds, the user might allocate 15 seconds for that command to provide some timing margin.

6.2.2.5 Choosing the Integration Time

Longer integration times result in longer command execution times. Thus, for the maximum observation frequency, shorter integration times are desirable. However, shorter integration times result in a higher contribution of random noise resulting from the thermal noise inherent in all radiometers. Figure 38 illustrates the impact of integration time on the thermal noise component (ΔT_n) of the total random noise.

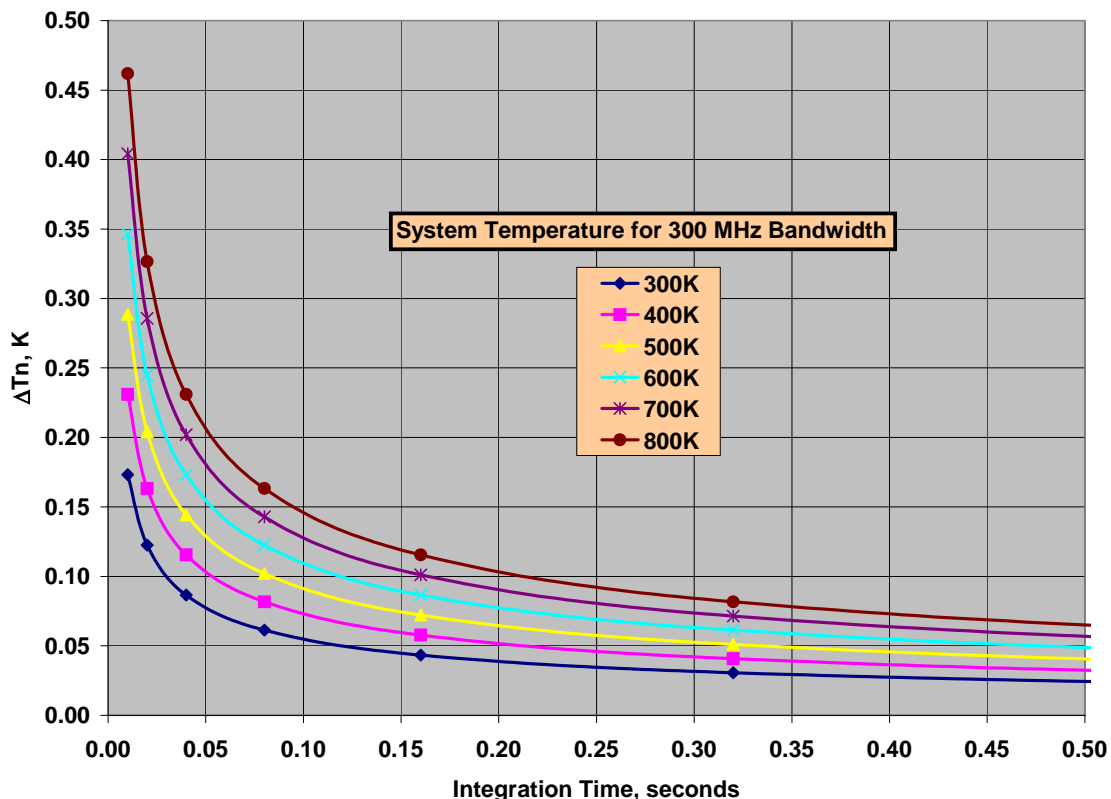

Figure 38 Theoretical Thermal Noise for Radiometers

For most applications, an integration time of ~200 msec is optimum for the Profiling Radiometers. Below 50 msec, ΔT_n increases rapidly, and due to constant command overhead times, such as for antenna positioning between commands, further reduction of the integration time does little to reduce the command execution time. On the other hand, ΔT_n reaches such a small value above 500 msec that other sources of noise (i.e., atmospheric and residual 1/f) become dominant. Thus, there is normally very little benefit resulting from longer integrations.

6.2.3 Factory Procedure Files

The following standard procedure files are provided (xxx is a site dependent 3-letter code):

B&I35.prc	performs alternating a observations of the internal ambient target and an external cryogenic LN2 target; used mainly for diagnostic use.
Tip21.prc	performs continuous 21 channel tip calibrations (MP1500A and 3000A only)
Zen_35_tb.prc	performs continuous zenith observations of all 35 brightness temperatures (MP3000A only).
xxx_zen_ret.prc	performs continuous zenith retrievals of temperature, vapor density, liquid density, relative humidity profiles (MP1500A produces only vapor density profiles) and integrated vapor and liquid scalar values based on 22 zenith brightness temperatures and 4 surface met observations. (For MP1500A, 14 zenith brightness temperatures and 3 surface met).
xxx_zen_ret_tip.prc	same as above with added 21-channel tip calibration.
xxx_zen35_ret_scan4f.prc	performs continuous 35 channel zenith brightness temperature observations, retrievals from the observations as in xxx_zen_ret.prc and an azimuth scan (6 angles) of 4 frequencies at 30 degrees elevation brightness temperatures.

6.2.4 Neural Network Files

Atmospheric temperature, humidity and liquid profiles are retrieved from Profiling Radiometer measurements (*level1*) using neural networks. The neural networks are trained using data from historical radiosonde soundings. Several years of radiosonde data from one or more sites in the same climatological region as the observation site are typically used for neural network training. The radiosonde soundings are forward modeled using atmospheric emission models and radiative transfer equations to provide brightness temperatures that would have been observed at ground level. The neural networks find the

temperature, humidity and liquid profile (atmospheric state) retrievals that best correlate with the radiometric observations. For GPS observations, a separate neural network file is used. The neural network files are trained using the Stuttgart Neural Network Simulator and a standard back propagation method.

New Profiling Radiometers are delivered with one set of neural network files included. The user must specify the region of operation, or radiosonde site to be used for training. Additional neural network files may be purchased for other sites. Contact Radiometrics Sales and Marketing for further information.

To change neural network files to be used for real-time level2 processing, simply add the new neural network files to the operating folder and specify these files in the **nnret** commands used for retrievals.

NOTE: Operation of the radiometer with neural network files trained for a different site may produce profiles with significant error. However, the level0 and level1 data will not be affected. In the event the radiometer is operated with incorrect neural network files, the level1 data can be reprocessed with the correct neural network files at a later time.

6.3 Output Files

There are 5 standard output files generated by the Operating Code. Common conventions used in all the files are described below, followed by descriptions of each output file type.

6.3.1 Output File Name Conventions

All output files use the .csv extension to indicate to other application programs that the files conform to the industry standard *comma separated variable* data base format. Most mathematical analysis, spreadsheet and database programs can open and manipulate the data in these files with little or no reformatting. All output files are named automatically using the following format:

yyyy-mm-dd_hh-mm-ss_xxx.csv

...where

yyyy	is the year when the file was started
mm	is the month of the year
dd	is the day of the month
hh	is the hour of the day
mm	is the minute of the hour
ss	is the second of the minute

...and xxx defines the output file type as follows:

xxx=lv0	level0 file
xxx=lv1	level1 file
xxx=lv2	level2 file
xxx=tip	TIP calibration file
xxx=ln2	LN2 calibration file
xxx=ser	com port log

This file naming convention orders the files chronologically when sorted alphabetically by name.

6.3.2 Record Number

All output files contain a sequential record number in the first field, starting with the number 1. In the event a file has been sorted for analysis purposes by record type, elevation angle, or any other parameter in the file, the record number field can be used to restore the order of the file to its original order.

6.3.3 Date/Time Conventions

All output files contain a date/time stamp in the second field of all records that contain time dependent data. All output files use the following date/time stamp convention for each record in the file:

mm/dd/yyyy hh:mm:ss

...where mm is the month
 dd is the day
 yyyy is the year
 hh is the hour
 mm is the minute
 ss is the second

The time corresponds to the time of the completion (end) of the observation set.

NOTE: If a file is opened in Excel or similar applications, the date/time stamp can be reformatted easily to any other standard format and saved in that revised format.

6.3.4 Record Type Conventions

All output files contain a record type number in the third field of all records. The record type number defines the header or data type in that record. Record types for each file type are grouped in blocks and numbered sequentially beginning with the number assigned to the header for that block. Record headers define all the fields in each block.

Data is logged sequentially in the order of the observations. For some types of analysis, it is more convenient to sort the data based on different parameters. Sorting a file by record type is often a useful first step to analysis. When a file is sorted by record type (third column in a spreadsheet, for example), the data automatically sorts into logical blocks with the appropriate header for each block appearing at the top of each block. Second level criteria can be used to sort the data within each block by elevation or azimuth angle, ambient temperature, or any other field appearing in the record.

6.3.5 Level0 File

Level0 files contain raw, unprocessed data in engineering units. A *level0* file is produced for all modes of operation and all options that can be selected from the main menu. *Level0*

files contain 100% of the information needed to reprocess the raw data with alternative calibration information or algorithms. *Level0* files contain the following record types:

Record type	Description of Record Type
00	Record type for all error reports
15	Header for sky observations
16	obs command sky observation
17	cal21 command sky observation
25	Header for observation of internal ambient black body
26	BB observation for trcvcal command
30	Header for tdp command (GPS) records
31	GPS time/date/position data
40	Header for surface met records
41	Tamb, RH, pressure, Tir and rain sensor
60	Header for LN2 calibrations
61	Record of LN2 cal data (includes BB, LN2 observations)
90	Header for housekeeping data (eng command)
91	eng command data
99	Record type for echo of mp.cfg file to level zero file

Figure 39 *Level0* Record Types

6.3.6 *Level1* File

Level1 files contain real-time brightness temperatures for each channel specified in the configuration file. Real-time *level1* files are produced from contemporaneous *level0* data and calibration information in the configuration file. *Level1* files contain the following record types:

Record type	Description of Record Type
40	Header for surface met records
41	Surface met data record
50	Header for sky observations
51	obs command sky observation data record

Figure 40 *Level1* Record Types

6.3.7 *Level2* File

Level2 files contain records of real-time retrievals of temperature (K), water vapor (g/m^3), relative humidity (%) and liquid water (g/m^3) profiles. The retrievals are produced using the contemporaneous *level1* data and the neural network files specified in the configuration file. *Level2* files contain the following record types:

Record type	Description of Record Type
100	Header for vector retrieval index
101	Vector retrieval index entry
200	Header for surface met records
201	Tamb, RH, pressure, Tir and rain sensor
300	Header for scalar retrieval records
301	Scalar retrieval data record
400	Header for vector retrieval records (58 heights)
401	Temperature vector retrieval data record (profile)
402	Vapor Density vector retrieval data record (profile)
403	Liquid Density vector retrieval data record (profile)
404	Relative Humidity vector retrieval data record (profile)

Figure 41 Level2 Record Types

6.3.8 TIP Calibration File

TIP files contain the results of *successful* tip calibration attempts. For each **cal21** command in a Procedure File, the *level0* data is processed in real-time by the TIP calibration algorithm. For each TIP frequency specified in the configuration file, atmospheric opacity is computed for each elevation angle. The TIP calibration algorithm attempts to fit all the opacity values for each frequency to a linear function of air mass (number of equivalent atmospheres for a given elevation angle). If the linear regression for all channels is better than the regression threshold “r” specified in the configuration file, then the tip is considered “good”, and the computed values of Tnd and r for each frequency are included in the *TIP* output data file. *TIP* files contain the following record types:

Record type	Description of Record Type
10	Header for current calibration data in configuration file
11	Current calibration data
30	Header for cal21 calibration results
31	Values of Tnd @ TkBB=290 K and r values for all frequencies in TIP Cal

Figure 42 TIP Calibration Record Types

A copy of the current Tnd calibration data contained in the configuration file is copied to the top of the *TIP* file (record types 10 and 11). This provides a quick way to compare new TIP calibration derived values of Tnd to the current operational values as described in Section 5.2.2. The values of Tnd are normalized to the value that would be observed when TkBB = 290 K.

6.3.9 LN2 Calibration File

LN2 calibration files contain the values of Tnd computed from individual LN2/Black Body observation sets during an LN2 calibration, for all channels specified in the configuration file. LN2 files contain the following record types:

Record type	Description of Record Type
10	Header for current calibration data in configuration file
11	Current calibration data
30	Header for LN2 results
31	Values of Tnd @ TkBB=290 K for all frequencies in configuration file ³⁶

Figure 43 LN2 Calibration Record Types

A copy of the current Tnd calibration data contained in the configuration file is copied to the top of the LN2 file (record types 10 and 11). This provides a quick way to compare new LN2 calibration derived values of Tnd to the current operational values. The values of Tnd are normalized to the value that would be observed when TkBB = 290 K.

6.4 Time Synchronization

The date/time stamp in files and output file names is derived from the date/time in the Microsoft Windows Operating System. The Windows calendar clock is updated using the GPS receiver time immediately before the beginning of each new set of output files.

6.5 Reprocessing

Users can reprocess *Level0* files with alternative calibration values or advanced algorithms to improve the accuracy or reduce the random noise in *level1* data. *Level1* files can be reprocessed with alternative retrieval algorithms.

³⁶ These values are calculated using a simplified receiver model. When the calibration ends, updated values of Tnd, Alpha, and dTdG are calculated and written to mp.cfg.

7 Maintenance and Trouble Shooting

This Section provides information on routine maintenance and calibration of the Profiling Radiometer, including Surface Met Sensors, and the controlling computer.

7.1 Instrument Maintenance

7.1.1 Radiometer Calibration

When installed at a permanent site and configured to operate on a continuous basis, the Profiling Radiometer should remain calibrated within specifications up to 6 months or longer in typical operating conditions. However, the calibration can be effected by radome degradation, long-term drift, extreme weather, changes to the installation environment, and other factors. It is therefore recommended that the calibration be monitored on a regular basis, at least monthly, and updated as needed.

The 22-30 GHz channels can be monitored easily by checking the TIP calibrations regularly. If **cal21** commands are included in the procedure in use, pressing the **T** key will produce real-time graphs of all the Noise Diode values (Tnd) in current use (straight lines), and a time series of the most recent values derived from real-time TIP calibrations. The numeric values of Tnd in current use are also indicated on the **T** display. If the daily averages of the new values of Tnd deviate by more than 0.5% from the Tnd values in use, then the user should *consider updating* the values in use as described in Section 5.2. Note that it is normal for real-time values of Tnd to deviate from “truth” by up to 2% when the atmosphere is changing rapidly, such as when a front is moving through the area. Therefore, the calibration should be changed only if the average of many “good” TIP derived Tnd values deviates from the values in use. See Section 5.2 for the recommended procedures to identify when TIP calibration values are of good quality.

The 51-59 GHz and 22-30 GHz subsystems are predominantly independent. Therefore, the calibration status of one is not necessarily indicative of the other. The 51-59 GHz channels can only be calibrated using an external LN2 target. Therefore, it is recommended that an LN2 calibration be performed every 6 months, or sooner if accuracy is in question. Follow the procedures in Section 5.1 to perform an LN2 calibration.

7.1.2 Antenna Pointing Calibration

The accuracy of most sky observations is dependent on accurate antenna positions. The elevation angle accuracy is dependent on the accuracy of the leveling process described in Section 3.4. The instrument should be checked for proper leveling at least annually, following severe wind conditions, and any time TIP calibration attempts fail to pass the internal quality test more often than normally observed. Refer to Section 3.4 for proper leveling procedures.

If the optional Azimuth Positioner is installed, the instrument azimuth should be checked periodically. To check the azimuth reference position, end any data collection in progress by pressing **Q** on the control computer, then cycle the Profiling Radiometer power by

switching the power off for 10 seconds, then back on. Once the Profiling Radiometer reaches its azimuth index position, it should be reoriented with the connector panel due east and the antenna pointed in the north-south plane. To adjust the Profiling Radiometer azimuth reference, loosen the T-bolt slightly and gently rotate the Profiling Radiometer so that the connector panel points due east, and then re-tighten the T-bolt. The user may want to use a compass for this orientation. If so, the magnetic declination at the installed site must be included in the determination of true north.

7.1.3 Radome Replacement

Airborne pollutants will eventually coat the radome. Any foreign matter on the radome may increase the observed sky temperatures. The radome may be washed by pouring clean water over it and left to air-dry. *It should not be touched or rubbed with a sponge or towel.* Doing so will degrade the hydrophobic material. When the surface of the radome becomes visibly dirty, and it cannot be cleaned with free flowing water, the radome should be replaced to ensure optimum performance of the Profiling Radiometer. The frequency of radome replacement is site dependent and should be determined by periodic examination. Check the radome every 30 days until a maintenance interval can be established by the user, based on local conditions.

To replace the radome, quit the current procedure in progress, if any, (Press **Q**) and turn off the power. Next, disconnect the power cable, from the source first, then at the Profiling Radiometer. Disconnect the short "pigtail" cable between the SuperBlower and radiometer, and the GPS cable. Then remove the hood by unlatching the 6 latches located along the sides and carefully lifting it straight up and off of the Profiling Radiometer. Place the back end of the hood on a clean work surface so that the inside is accessible. Support the hood as necessary to protect the IRT assembly. Remove all 4-40 Nylock nuts (32) securing the Radome Window Retainer as shown in Figure 44. After all of the nuts are removed, carefully remove the Radome Window Retainer and the old radome.



Figure 44 Radome replacement

To install the new radome, reverse the process. *Observe the labels indicating the inside and outside of the radome.* Avoid touching the surface of the new radome as much as possible. The new radome should be grasped only by the edges to ensure that the hydrophobic coating is not compromised. Tighten the nut just enough to slightly compress the radome. *Do not over-tighten the nuts.*

7.1.4 S3 Temperature and RH Sensor Maintenance

The Rotronic S3 Temperature and RH sensor is a precision instrument that will maintain calibration for 6 months or more in normal service. However, if dust or other local air pollution is excessive, the screen on the sensor may need to be cleaned more often. To access the S3 Temperature and RH sensor, loosen the 10 thumbscrews that secure the SuperBlower End Cover. Gently remove the cover by pulling outward with the handle while holding the bottom lip. See Figure 45.

To clean the S3 screen, the S3 probe can be left in the mounting socket. Simply unscrew the screen and remove to the right. See Figure 46.

Caution: The S3 sensor is a delicate instrument requiring careful handling. Nothing should be allowed to come in contact with the active sensor elements inside the screened protective cover.

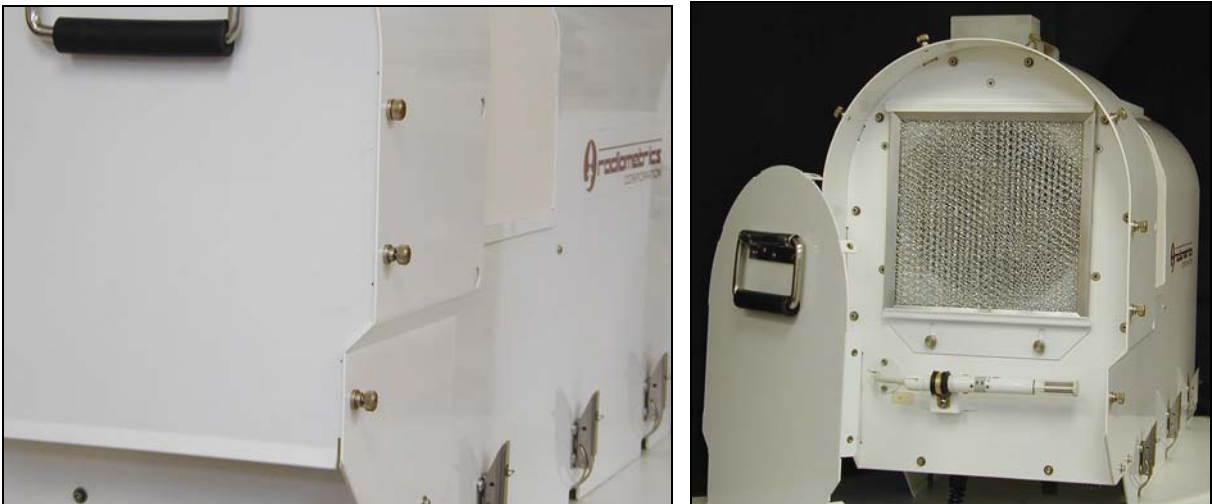

Figure 45 SuperBlower End Cover removal

To clean the screen in the field, use pure compressed air. Pure compressed air is available in small cans for cleaning photography equipment, computers, and other electronic equipment. Air should be blown through the screen from the inside to the outside as shown in Figure 46. Avoid using compressed air from an air compressor because oil and water from the compressor can contaminate the sensor.

If access to ultrasonic cleaning is available, it can be used with distilled water to clean the screen. Chemical cleaners should be avoided because of possible contamination.

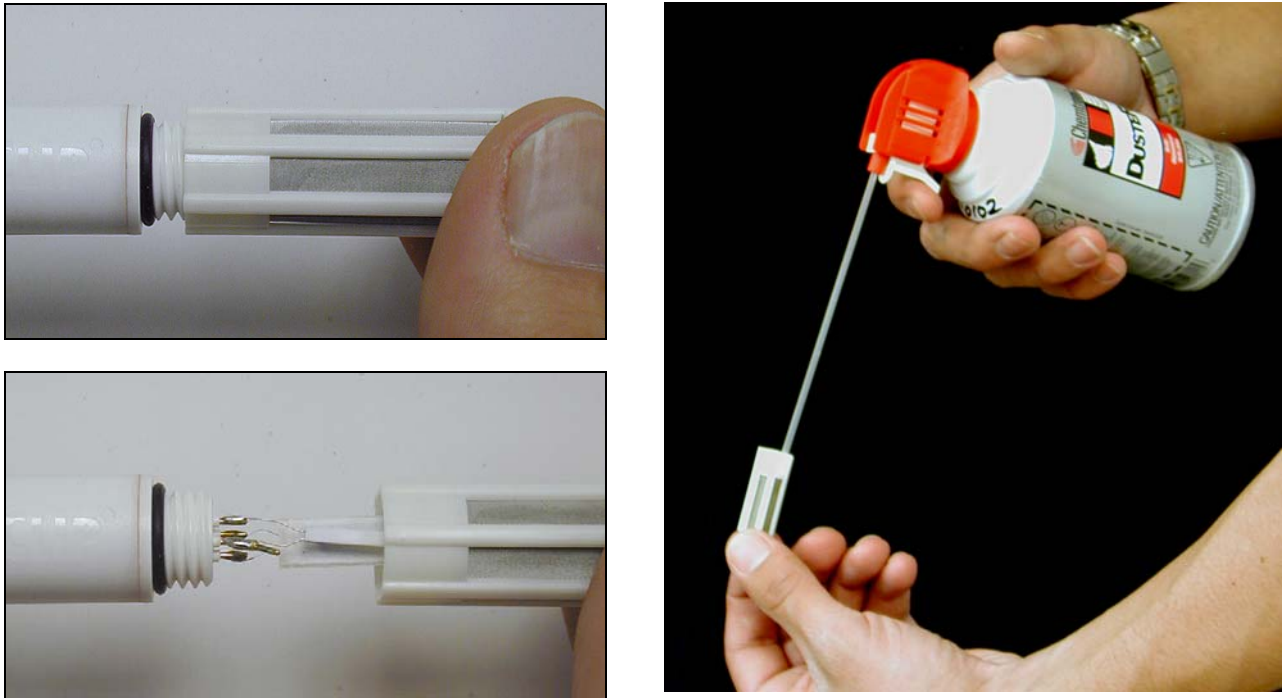

Figure 46 S3 screen removal and cleaning

To remove the S3 sensor for laboratory calibration or replacement, rotate the Gray Locking Collar on the probe until the black dots on the Gray Locking Collar line up with the black dots on each side of the Gray Locking Collar. Unplug the probe from the Gray Locking Collar by carefully pulling the probe to the right. See Figure 47.

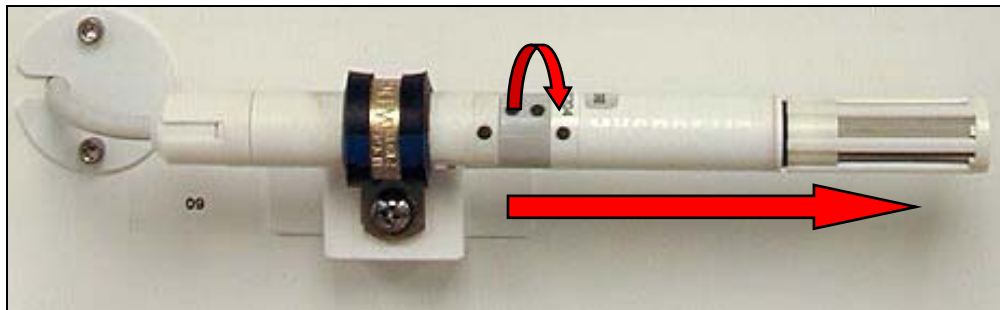

Figure 47 S3 sensor removal

New [S3 sensors](#) are available from Radiometrics, or directly from the Rotronic Corporation. The S3 sensor can be calibrated in the laboratory by the user by using the Rotronic [communications pod](#), available directly from Rotronic.

If the user has access to high accuracy field standards for Tamb and RH, and wishes to adjust the S3 calibrations in the field, linear offset values may be entered in the configuration file (mp.cfg) in place of the default values (0.0) as follows:

```
+0.00      :Tamb correction
+0.00      :Rh correction
```

Offset values for Tamb and RH are *added* to the measured values. For example, if the temperature observed with a high quality standard (placed close to the inlet of the SuperBlower) is 0.2K higher than the air temperature recorded by the Profiling Radiometer, then an offset of +0.2 should be entered in the field provided for the Tamb offset in the mp.cfg file. Because the expected difference is normally very small, it may be necessary to average the data for 1-2 hours to obtain a meaningful estimate of the bias.

7.1.5 SuperBlower Filter Cleaning and Replacement

The SuperBlower impeller produces a high volume of airflow. To protect the radome and impeller, the intake is filtered with a standard aluminum mesh filter. This filter should be inspected and serviced periodically. The frequency of service is site-dependent and must be determined by the user. Following installation at a new site, inspect the radome every 30 days until a maintenance interval can be established by the user, based on local conditions.

To remove the filter, first remove the SuperBlower End Cover as described in Section 7.1.4. Then loosen the two thumb screws holding the filter retaining bracket, as shown in Figure 48. Remove the filter by sliding the retaining bracket down and lifting the filter out.

If the filter is not matted with insects or other difficult to remove debris, compressed air can be used to clean it. For insects and other heavy debris, the filter should be cleaned with water and mild detergent, compressed air, and then rinsed thoroughly. Filters that cannot be cleaned due to excessive debris should be replaced with a new filter.

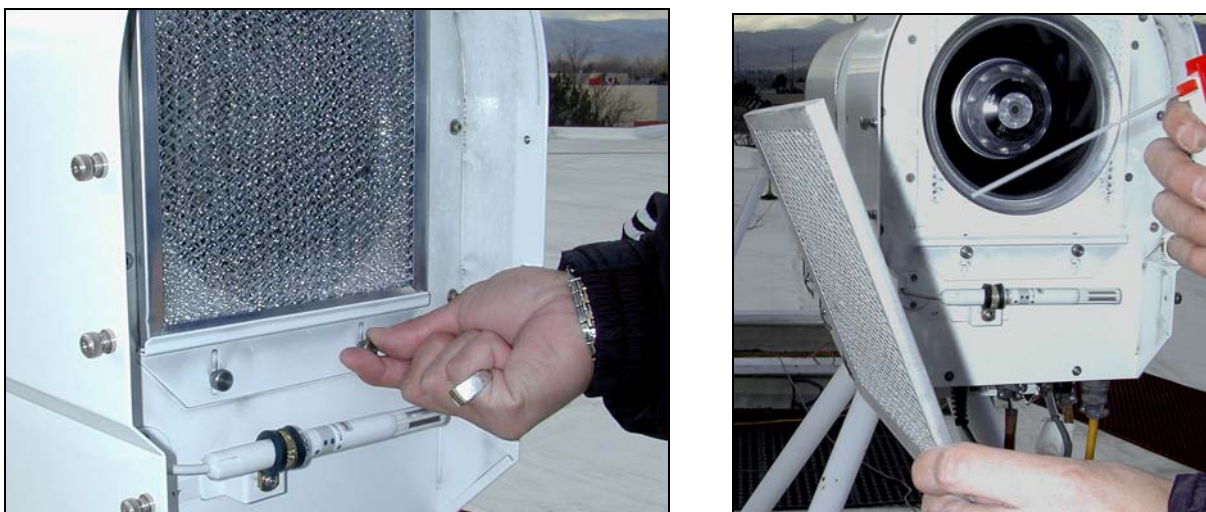

Figure 48 SuperBlower filter removal and cleaning

Replacement filters are available from Radiometrics and many local hardware stores. The nominal size is 200 X 200 X 5 mm.

7.1.6 Rain sensor Board

The rain sensor board, located on the top of the SuperBlower, detects the presence of liquid water by measuring the resistance between the inter-digital conductors. Excessive surface contamination from pollution, salt spray, etc. will alter the transfer function

(volts/water-drop). This board should be cleaned periodically with fresh water and a non-abrasive cloth or paper towel to remove all foreign matter. The board is gold plated to minimize corrosion, but will degrade over time in severe environments. If the rain sensor fails to provide satisfactory service after cleaning, it may need to be replaced. Replacement boards are available from Radiometrics.

To replace the board, unscrew the four mounting 6-32 screws and gently lift the board up until the small connector on the bottom is visible (2-3 cm). Unplug the small connector on the old board, plug in a new board, and then replace the four mounting screws.

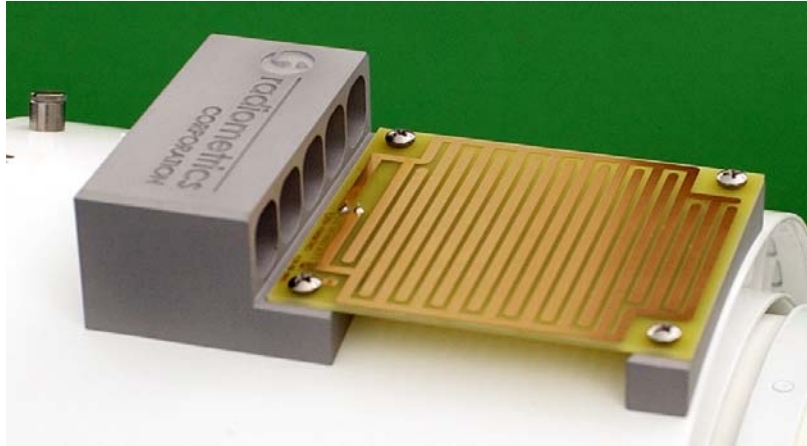

Figure 49 Close-up view of Rain Sensor board

7.1.7 IRT Window Maintenance

The IRT window located on the top of the Profiling Radiometer. It should be checked periodically for contamination. For accurate cloud base temperatures, the window surface must be free of dust and other contamination. The frequency of service is site-dependent and must be determined by the user. Following installation at a new site, inspect the IRT window every 30 days until a maintenance interval can be established by the user, based on local conditions.



Figure 50 GPS Receiver on the left; IRT window on the right

A soiled window can be cleaned with a standard camera lens cleaning kit available from photography stores. Paper towels and many types of cloth are too abrasive, and may damage the surface. Before using a lens cleaning tissue, cloth or brush to clean the window, pure compressed air should be used to remove as much dirt as possible. Replacement windows are available from Radiometrics.

7.1.8 Cables

Normally, the power and data cables do not require any periodic maintenance. However, it is good practice to inspect the cables periodically to ensure that they have not been damaged by weather, accident, rodents, etc.

7.2 Controlling Computer

No periodic maintenance is required for the control computer hardware beyond what is recommended by the computer manufacturer. Refer to the separate computer manufacturer documentation supplied for computer maintenance suggestions.

7.2.1 Operating System Updates

Microsoft releases updates to the Windows Operating System software (OS) quite often. The OS can be configured to update automatically or notify the user that updates are available. It is generally advisable to keep the OS up to date with revisions as they are released. However, the automatic update feature should not be enabled. Automatic updates can interfere with normal data collection, so it is better to install updates manually, at a time convenient to the user.

7.2.2 Operating Code Updates

Radiometrics may release updates to the Operating Code from time to time to enhance performance, add features or fix bugs. Generally, these updates can be installed by replacing the application file (**mp_V4.32.exe**) in the Operating Folder, without changing any other files. Occasionally, updates require the installation of additional files, or the modification of some existing files. Detailed installation instructions will be provided with all new code releases. Contact Radiometrics Sales and Marketing for information on the latest codes available, and advice on the best code to use for a given application.

7.2.3 Neural Network and Procedure File Updates

Neural networks are specific to the site where the radiometer will be operated. If the radiometer is moved from the original site and the new site has an elevation more than 100 meters different than the old site and/or a radically different climate, new neural networks should be ordered from Radiometrics. The neural network files (.net extension) and the procedure files (.prc extension) should be placed in the main operating directory. The macro files (.rmc extension) should be placed in the *macro* sub-directory. The new procedure files will then be available for selection when the operating program is run.

7.2.4 Firmware Updates

The MCM and microwave receivers store firmware in flash memory. This firmware can be updated from time to time using a code download tool installed on the control computer.³⁷ In the event any of the firmware needs to be updated, Radiometrics will supply detailed instructions on the procedure. Note that MCM firmware can be installed for you by the factory via Internet.

7.2.5 Virus Protection and Firewall

Radiometrics does not supply virus protection software with control computers. However, if the user connects the controlling computer to the Internet, appropriate firewall and virus protection software may be enabled or added by the user, provided it is configured to operate without restarting the computer from time to time.

7.2.6 Error Messages

If the Operating Code encounters a fatal or non-fatal error, it will attempt to write an Error Message to the level0 file marked record type 00. Appendix B contains a list of all the Error Messages that may be written to the level0 file. In the event that the user encounters problems requiring factory assistance to resolve, be prepared to give the technician information about the Error Message history.

³⁷ The Downloader Tool can also be installed on any other computer as required to update radiometer firmware.

8 Warranty and Service

Radiometrics warrants its Profiling Radiometers for one year from the date of delivery against defects in workmanship and materials under normal use and service. Radiometrics will repair or replace, at Radiometrics option, any equipment found to be defective within this warranty period, EXW Boulder Colorado. Customers are responsible for the cost of all inbound and outbound freight, insurance and taxes, if any. This warranty excludes the control computer, which is covered under the original equipment manufacturer's warranty.

For information or service, contact Radiometrics as indicated below. Be prepared to describe your problem in detail. If field repair is not considered possible, request a Return Materials Authorization (RMA). Radiometrics will remedy your problem as soon as possible and return the unit.

The Profiling Radiometers are protected under U.S. and foreign patents. The software and firmware are copyrighted.

Please direct inquiries to:

**Radiometrics Corporation
2840 Wilderness Place, Unit G
Boulder, CO 80301-5414
USA**

**Tel: (303) 449-9192
Fax: (303) 786-9343**

8.1 European Certification

The MP-3000A has received European Certification in conformance with the European Union Directives:







- 73/23/EEC (93/68/EEC) Low Voltage Directive
- 89/336/EEC Electromagnetic Compatibility Directive

Based on the following standards:

- EN61010 Safety of Electrical Equipment for Measurement, Control, and Laboratory Use
- EN 55022 (Class A) Limits and methods of measurements of radio interference characteristics of information technology equipment.
- EN 50082-1 Electromagnetic compatibility - Generic immunity standard -Industrial environment

8.2 Symbols Legend

Below is a description of the safety marking symbols that appear on the Profiling Radiometer. These symbols provide information about potentially dangerous situations which can result in death, injury, or damage to the instrument and other components.

 Caution, hot surface	 Main power off
 Caution, refer to manual	 Main power on
 Caution, risk of electric shock	 Alternating Current

Appendix A: TP-2000 Tripod Assembly

Unpack and inspect the tripod parts for signs of damage or missing pieces. The following parts should be included:

- (3 ea.) Foot Assembly.
- (3 ea.) Telescoping Leg Assembly.
- (3 ea.) Strut.
- (1 ea.) Triangular Top Plate with eyebolt.
- (1 ea.) Hardware Kit containing:

Foot Assembly Hardware:

- (3) 3/8" x 1-3/4" cap screws.
- (6) flat washers.
- (3) lock nuts.

Cross Strut Hardware:

- (6) 3/8"x 1" cap screws.
- (6) Lock nuts.

Top Plate Hardware:

- (6) 3/8"x 3/4" cap screws.

(1 ea.) Tool Kit containing:

- (1) 1/4" Allen wrench.
- (1) 5/16" Allen wrench.
- (1) 9/16" box / open-end wrench.
- (1) 9" Magnetic bubble level.

(1 ea.) Center Pull Anchor kit. Containing:

- (3) SS oval threaded connector.
- (1) SS turnbuckle.
- (1) SS eyebolt.
- (3') SS 3/16" corrosion resistant chain



Figure 51 Radiometrics TP-2000 Tripod Parts.

Assembly Instructions

1. Attach (1) foot assembly to each leg assembly using (1) 3/8" x 1-3/4" cap screw, (2) flat washers, and (1) 3/8" lock nut. DO NOT TIGHTEN the screws at this step.
2. Attach the other end of each leg assembly to the triangular top plate using (2) 3/8" x 3/4" SS cap screws for each leg. DO NOT TIGHTEN the screws at this step.
3. Attach the (3) cross struts to the leg brackets using (2) 3/8" x 1" cap screws and (2) 3/8" lock nuts on each cross strut.
4. Tighten all screws using 5/16" Allen wrench and 9/16" box wrench.
5. Adjust to desired height as follows:
6. Loosen the (3) collar clamps using the 1/4" Allen wrench. Extend the lower leg by pulling downward on the foot. Repeat this step for each leg as required to set instrument height. If the site is not level, adjust the legs to different lengths as required to level the triangular top plate. Re-tighten each collar clamp.
7. The tripod can be secured using any of the following methods:
 - a) **Center Pull Guy Method:** If a single secure "Anchor Bolt" can be provided directly under the tripod, this method can be used as follows:
 - Position the tripod directly over the anchor bolt.
 - Attach the oval threaded connector of the pull chain assembly to the eyebolt on the triangular top plate.
 - Attach the other end of the chain to the anchor bolt using the threaded chain link, (moved to the required position on the chain).
 - When the chain is attached at both ends and the tripod is leveled at the desired height, take up the slack with the turnbuckle. A downward force of 25-30 lbs. is sufficient.
 - b) The feet can be secured using **lag bolts** through the small holes in the feet.
 - c) Tent **stakes** or similar can be used to secure the feet using the large holes.
 - d) **Sand bags** or similar dead weights can be applied to the feet.

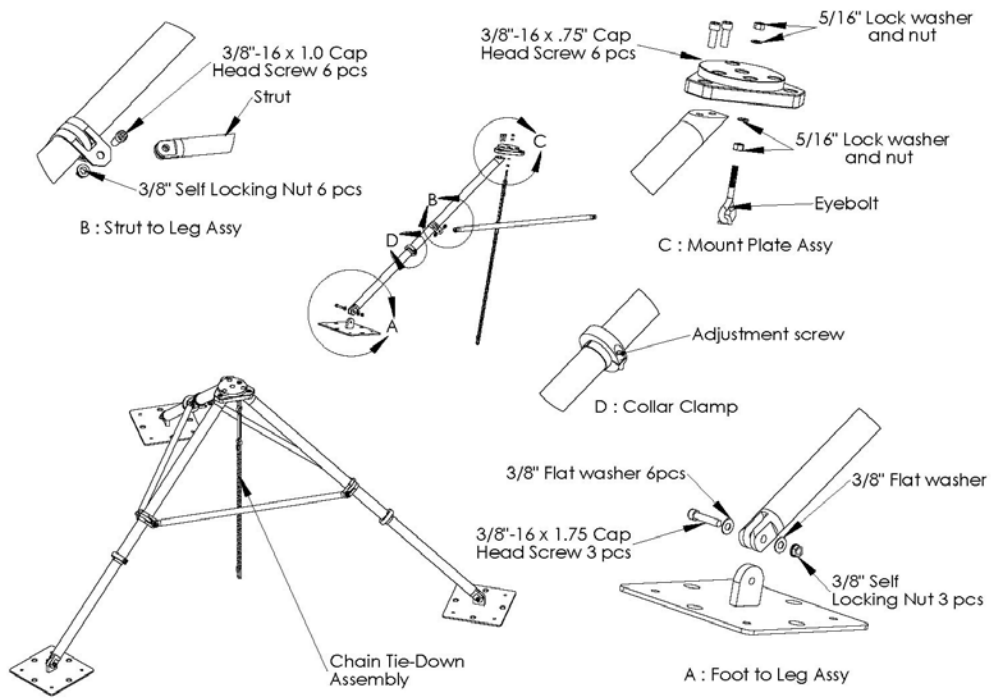

Figure 52 Tripod Assembly Components.



Figure 53 Tripod Fully Assembled

Appendix B: Error Messages for A series Radiometers

Errors are reported in the `_lv0.csv` file. The most recent error is also shown on-screen in the lower left corner. In the `_lv0.csv` files, all errors have a record type of 0 so that they sort to the top when the file is sorted by record type. There are two basic types of errors: errors produced by the operating code (usually due to configuration problems or operating computer problems) and errors from the different sub-systems of the instrument itself – these errors will often cause operating code errors as well.

Radiometer operating program errors

These errors do not have a number and are descriptive of the problem that occurred. They include problems with the computer, operating system and file system. Examples of these types of errors are an inability to open the serial port connection to the instrument because it is in use by another program or because the serial port specified in `mp.cfg` does not exist. File system errors include attempts to open files that do not exist (for example, specifying non-existent neural network files or macro files in a procedure file) and errors related to an inability to access a file (because it is locked by another program, read-only, or on a network drive that is not accessible for some reason).

There are also errors related to incorrect procedure files. These include specifying frequencies in TRCVCAL and OBS commands that are not present in the `mp.cfg` file. This results in a “Factory Calibration Not Available” error. Specifying a frequency in an OBS command that has not previously appeared in a TRCVCAL command will result in a “ERROR – Trcv not available at f = xxxxx” and /or “ERROR – Gbb not available at f = xxxxx” where xxxxx is the frequency in MHz.

Errors related to problems communicating with the instrument include RS-232 timeout errors (the instrument did not respond in the expected time) and command retry errors. If this happens only once, there is probably no problem but repeated timeouts and retries indicate a more serious problem. The operating code should be stopped, the instrument power turned off for 30 seconds, then back on and the operating code re-started.

Individual device errors

There are 5 sub-systems in the instrument that produce numerical errors. These are reported in record type 0 records with the device name (one of MCM, RCV0, RCV1, EL, AZ - some devices may not be present in a particular instrument), the number of errors, followed by the numeric error codes.

MCM errors

Error Number	Error code	Description
0	MEC_PORTA_IN_OVR	MCM input buffer overflow for port A
1	MEC_PORTB_IN_OVR	MCM input buffer overflow for port B
2	MEC_PORTC_IN_OVR	MCM input buffer overflow for port C
3	MEC_PORTD_IN_OVR	MCM input buffer overflow for port D
4	MEC_PORTA_OUT_OVR	MCM output buffer overflow for port A
5	MEC_PORTB_OUT_OVR	MCM output buffer overflow for port B
6	MEC_PORTC_OUT_OVR	MCM output buffer overflow for port C
7	MEC_PORTD_OUT_OVR	MCM output buffer overflow for port D
8	MEC_SPRINT_PRECISION	Attempted print of float with over 8 digits total
9	MEC_SPRINT_PARAMETER	Invalid parameter passed to sprintf function
10	MEC_ADC_CAL_TIMEOUT	ADC calibration timeout
20	MEC_DIO_BAD_CHECKSUM	Incorrect checksum from DIO
21	MEC_DIO_BAD_DATA	Incorrect data from DIO
22	MEC_ADC_SETUP_UPDATE_ALL	Failed to setup ADC for housekeeping
23	MEC_GPS_OVR	GPS string overflow
24	MEC_IRT_OVR	IRT string overflow
25	MEC_OBS_IN_PROGRESS	Attempt to start an observation while an observation is in progress
27	MEC_PWM_BAD	Attempt to set pulse width to invalid value
28	MEC_ATT_N_TIMEOUT	Wait for I2C Attention: line timeout
32	MEC_ADC_SETUP_PTC	Failed to setup ADC for pressure thermal control
36	MEC_ADC_SETUP_PR	Failed to setup ADC for pressure reading
37	MEC_VIDA_PRESENT_FAILED	Process to detect VIDA synthesizer failed
38	MEC_MICROSOURCE_PRESENT_FAILED	Process to detect Microsource synthesizer failed
41	MEC_O_SET_SYNTH_NEG	Attempted to set synthesizer at end of observation
42	MEC_O_SETUP_ADC_FAILED	Failed to setup ADC for observation
46	MEC_UPDATE_ADC_FUNCT_FAILED	Update ADC readings function failed
47	MEC_UPDATE_PRESSURE_THERMAL_FUNCT_FAILED	Update pressure thermal function failed
48	MEC_UPDATE_OBS_FUNCT_FAILED	Update observation function failed
49	MEC_UPDATE_TILT_FUNCT_FAILED	Update tilt function failed
50	MEC_UPDATE_SURF_MET_FUNCT_FAILED	Update surface met function failed

51	MEC_UPDATE_PRESSURE_FUNCT_FAILED	Update pressure function failed
53	MEC_ADC_RAIN_SETUP	Failed to setup ADC for rain sensor
54	MEC_GET_TILT_TIMEOUT	Tilt timeout error returned by motor controller
55	MEC_GET_TILT_X	Tilt X error returned by motor controller
56	MEC_GET_TILT_Y	Tilt Y error returned by motor controller
57	MEC_GET_TILT_X_Y	Tilt X and Y error returned by motor controller
58	MEC_GET_TILT_UNKNOWN	Unknown error returned by motor controller
60	MEC_CHECKSUM	MCM code space checksum failed
61	MEC_LOAD_MICRO_TYPE	Attempted write to Microsource synthesizer while type is unknown
62	MEC_LOAD_MICRO_FREQ	Attempted to write invalid frequency to Microsource synthesizer
63	MEC_LOAD_VIDA_SEND	I2C write failed to VIDA synthesizer
64	MEC_BOTH_SYNTH_DETECTED	Both Microsource and VIDA synthesizers detected
65	MEC_BBP0_CONFIG	C command failed to configure receiver 0
66	MEC_BBP1_CONFIG	C command failed to configure receiver 1
67	MEC_BBP0_HOUSEKEEPING	R command failed to retrieve housekeeping data from receiver 0
68	MEC_BBP1_HOUSEKEEPING	R command failed to retrieve housekeeping data from receiver 1
71	MEC_R_IRT_NOT_PRESENT	R command for IRT issued while IRT not present
72	MEC_R_EL_SELF_TEST	Failed to request data from motor controller for self test command
81	MEC_ATTENTION_LOW	Attention signal active at unexpected time
82	MEC_SDA_STUCK	SDA signal low at unexpected time
83	MEC_SCL_STUCK	SCL signal low at unexpected time
84	MEC_I2C_BAD_STATE	I2C function reported incorrect state
85	MEC_I2C_UNKNOWN_RETURN	I2C function returned unknown state
86	MEC_VIDA_DETECT_READ	Read failed after detecting VIDA synthesizer
87	MEC_VIDA_DETECT_WRITE	Write failed during attempt to detect VIDA synthesizer
88	MEC_SEND_Rml2c_SEND_W	Write to receiver or motor controller failed
89	MEC_SEND_Rml2c_SEND_R	Read to receiver or motor controller failed
92	MEC_ATTN_LOW_AFTER_READ	Attention line stayed active after a read
93	MEC_READ_I2C_SIZE	Read to receiver or motor controller failed due to invalid data length
94	MEC_RAM_TEST	MCM RAM test failed

95	MEC_AE_NOT_PRESENT	A or E command issued but device not present
97	MEC_C_NO_RCV	O command issued but receiver not present
99	MEC_C_RCV0_A18	A18 command to receiver 0 failed
100	MEC_C_RCV1_A18	A18 command to receiver 1 failed
102	MEC_O_RCV0_S	S command to receiver 0 failed
103	MEC_O_RCV0_G	G command to receiver 0 failed
105	MEC_O_RCV1_S	S command to receiver 1 failed
106	MEC_O_RCV1_G	G command to receiver 1 failed
107	MEC_R_NO_RCV0	R command issued for receiver 0 while not present
108	MEC_R_NO_RCV1	R command issued for receiver 1 while not present
109	MEC_R_NO_EL	R command issued for elevation while not present
110	MEC_PMB_INIT_WRITE	PMB100 initialization write failed
111	MEC_PMB_INIT_READ	PMB100 initialization read failed
112	MEC_PMB_INIT_READ_SIZE	PMB100 initialization read size incorrect
113	MEC_I2C_DATA_NACK	Negative acknowledge during I2C communication
114	MEC_DUART_ERROR_PORTC	Error reported by DUART port C
115	MEC_DUART_ERROR_PORTD	Error reported by DUART port D
118	MEC_O_SYNTH_LOAD	Failed to set synthesizer during observation
119	MEC_FLASH_VERSION_VERIFY	Verification of data after flash write failed
122	MEC_FLASH_INVALID	Verification of data after flash read failed
123	MEC_C_LOAD_VIDA	Load VIDA synthesizer failed
126	MEC_SEND_Rml2c_INIT	Write during initialization of receiver or motor controller failed
127	MEC_ADC_NOT_IDLE_SMQ	ADC not idle before gathering housekeeping data
128	MEC_ERROR_BUFFER_FULL	Error buffer is full
129	MEC_AZ_CHECKSUM	Azimuth code space checksum incorrect
130	MEC_EL_CHECKSUM	Elevation code space checksum incorrect
131	MEC_IRT_TIMEOUT_TX	Timeout when sending to IRT
132	MEC_IRT_TIMEOUT_RX	Timeout when receiving from IRT
133	MEC_RMI2C_COMMAND_MISMATCH	Sent command does not match response for receiver or motor controller
134	MEC_RMI2C_CHECKSUM_MISMATCH	Received command checksum invalid
141	MEC_RMI2C_UNEXPECTED_LENGTH	Unexpected length for response

142	MEC_RMI2C_INVALID_RESPONSE	Unexpected response
143	MEC_RMI2C_G_BAD_STATE	G command data not ready when requested
144	MEC_BBP_SOFTRESET_FAILED	Soft reset request failed
145	MEC_SPRINT_LEFT_DIGITS	Not sufficient number of digits to left of decimal to print entire value
146	MEC_O_ADC_NOT_AVAILABLE	ADC in use during observation
147	MEC_PORTC_IN_TIMEOUT	DUART port C attempted to read 20 bytes out of 16 byte buffer
148	MEC_PORTD_IN_TIMEOUT	DUART port D attempted to read 20 bytes out of 16 byte buffer
149	MEC_INVALID_RCV_PASSTHROUGH_COMMAND	Pass through command to a receiver had an invalid format
150	MEC_GPS_INIT_PARTIAL_DATA_0	Partial command received from GPS receiver before command sent
151	MEC_GPS_INIT_PARTIAL_DATA_1	Partial command received from GPS receiver after command sent
152	MEC_O_SET_SYNTH_TYPE	Unknown synthesizer during observation command
153	MEC_INSERT_NULL	Invalid string passed to insert command
154	MEC_INSERT_SIZE	Invalid string length for insert command
155	MEC_R_RANGE	Index for R command out of range
156	MEC_R_RCV_RANGE	Index for receiver in R command out of range

RCV0 and RCV1 errors

Error	Error Code	Description
1	BEC_CHECKSUM,	Self-test checksum error
2	BEC_FLASH_INVALID,	Data Flash invalid
3	BEC_FLASH_ERASE,	Error erasing data flash
4	BEC_TEC_FAULT,	Temperature control fault
5	BEC_MAX_TEMPERATURE,	Max Temperature exceeded
6	BEC_FLOAT_ERROR,	Floating point output error
7	BEC_EIGHT_VOLT_RANGE,	8V supply out-of-range
8	BEC_VIDEO_RANGE,	Receiver voltage out-of-range
9	BEC_TEMPERATURE_RANGE_T1,	T1 sensor out-of-range
10	BEC_TEMPERATURE_RANGE_T2,	T2 sensor out-of-range
11	BEC_TEMPERATURE_RANGE_T3,	T3 sensor out-of-range
12	BEC_TEMPERATURE_RANGE_T4,	T4 sensor out-of-range
13	BEC_COMMAND_SIZE,	Command incorrect length

15	BEC_EXTRA_SYNC,	Too many sync pulse in obs cycle
16	BEC_TOO_FEW_SYNC,	Too few sync pulses in obs cycle
17	BEC_TIMING,	Observation timing error
18	BEC_FLASH_WRITE,	Error writing data flash
19	BEC_PLD_VER,	PLD version not compatible
20	BBP_ERROR_BUFFER_FULL,	More than 100 errors occurred since last F command.
21	BEC_PORTA_IN_OVR,	Input buffer overflow
22	BEC_PORTA_OUT_OVR,	Output buffer overflow
23	BEC_SPRINT_PRECISION,	Format precision error
24	BEC_SPRINT_PARAMETER,	Format error

Elevation and Azimuth Controller Errors

These errors are bit fields. The number reported is hexadecimal.

Bit	Error
0	RAM ERROR
1	TILT ERROR (elevation only)
2	HOME NOT FOUND
3	CW LIMIT (azimuth only)
4	CCW LIMIT (azimuth only)
5	Not used
6	Not used
7	Not used