

R/V Mirai Cruise Report

MR10-05

Arctic Ocean, Bering Sea, and North Pacific Ocean
24th August to 16th October, 2010
(Sekine-hama ~ Dutch Harbor ~ Dutch Harbor)

A high-angle, forward-looking photograph of the deck of the R/V Mirai. The ship's yellow mast and various deck equipment are visible. The sea is calm and reflects the bright sun, which is low on the horizon, creating a shimmering path of light across the water. The sky is a clear, pale blue with a few wispy clouds.

*Photo by Haruka Wakui,
Third officer of R/V Mirai*

Contents

Preface	-----	1
1. Cruise Summary		
1.1. Basic information	-----	2
1.2. Cruise track	-----	4
1.3. List of Participants	-----	6
2. Meteorological Observation		
2.1. GPS Radiosonde	-----	8
2.2. Doppler Radar	-----	17
2.3. Surface Meteorological Observation	-----	21
2.4. Ceilometer	-----	32
2.5. Measurements of DMS in seawater and atmosphere	-----	37
2.6. Behavior of Chemicals and Air-Sea Physical Flux in Sea Fog	-----	41
2.7. Air-sea surface eddy flux measurement	-----	42
2.8. Lidar observations of clouds and aerosols	-----	43
2.9. Sky radiometer	-----	46
2.10. Tropospheric aerosol and gas profile observations by MAX-DOAS	-----	47
2.11. Sampling for rainfall, atmospheric vapor, seawaters	-----	48
3. Physical Oceanographic Observation		
3.1. CTD/LADCP and water sampling	-----	54
3.2. Salinity measurement of sampled water	-----	69
3.3. XCTD observation	-----	76
3.4. Shipboard ADCP	-----	82
3.5. Micro structure observations	-----	86
3.6. Mooring Deployment	-----	89
3.7. ADCP and Plankton Net tow	-----	95

4. Chemical and Biological Observations

4.1. Dissolved Oxygen	-----	97
4.2. Nutrients	-----	103
4.3. Underway surface water monitoring	-----	123
4.4. pCO ₂	-----	130
4.5. Dissolved Inorganic Carbon	-----	133
4.6. Total Alkalinity, TA	-----	136
4.7. Oxygen isotope ratio ($\delta^{18}\text{O}$)	-----	140
4.8. Chlorophyll <i>a</i> measurements of total and size-fractionated phytoplankton	---	148
4.9. Primary, new and regenerated productions	-----	151
4.10. Bio-optical Observation	-----	154
4.11. Dissolved Iron (Fe)	-----	159
4.12. Bacterial community structures and its growth characteristics	---	161
4.13. Phytoplankton and microzooplankton	-----	169
4.14. Zooplankton	-----	180
4.15. Sediment trap and sediment core sampling	-----	189

5. Geological Observation

5.1 Sediment core sampling	-----	207
5.2. Sea bottom topography measurement	-----	235
5.3. Sea surface gravity measurement	-----	237
5.4. Surface three component magnetic field measurements	-----	239

Appendix

Appendix I. CTD and XCTD stations	-----	241
Appendix II. Sea ice and sea surface temperature distribution	-----	242
Appendix III. Bottle Data Inventory	-----	243

Preface

Over the past few decades, Arctic sea ice cover has decreased dramatically. The extent of summer Arctic sea ice cover is a sensitive indicator of climate change. The 2010 minimum is the third-lowest recorded since 1979, surpassed only by 2008 and the record low in 2007. Arctic sea ice is shrinking faster than climate change models predict. Japan Agency for Marine-Earth Science and Technology (JAMSTEC) conducted the R/V Mirai Arctic research cruise (MR10-05) in August – October, 2010. This cruise planned to cover the Pacific side of the Arctic Ocean and focused on;

To quantify on-going changes in ocean, atmosphere, and ecosystem, which are related to the recent Arctic warming and sea ice reduction.

To clarify important processes and interactions among atmosphere, ocean, and ecosystem behind changes of the Arctic Ocean.

In addition to main research theme as described above, fourteen science parties participated in this cruise for obtaining the data. This volume includes the simply notes instruments, methods, and preliminary results obtained on-board of the MR10-05.

MR10-05 was conducted as a part of international collaboration between JAMSTEC and Department of Fishery and Ocean, Canada. R/V Mirai occupied western part of Canada Basin and Chukchi Sea. Canadian Coast Guard Ship (CCGS) Louis S. St. Laurent occupied eastern and northern part of Canada Basin. Two vessels occupied full span of Pacific side of the Arctic Ocean.

We would like to thank Captains Nakayama and Ishioka, Chief Officer Inoue and Boatswain Oguni and the officers and crew of R/V Mirai for their many skills that contributed to the success of our cruise. We also would like to thank Chief Marine Technicians N. Sato and Nagahama and the marine technicians of MWJ and GODI for their generous support above and beyond the call of duty. We appreciate everyone who supports this cruise.

MR10-05 Chief Scientist

Motoyo Itoh

Arctic Ocean Climate System Research,

Research Institute for Global Change,

Japan Agency for Marine-Earth Science and Technology

1. Cruise Summary

1.1. Basic information

Name of Vessel	R/V Mirai L x B x D 128.58m x 19.0m x 13.2m, Gross Tonnage 8,672 tons Call Sign JNSR
Cruise Code	MR10-05
Title of the Cruise	Arctic Climate Oceanography
Undertaking Institute	Japan Agency for Marine-Earth Science and Technology (JAMSTEC)
Chief Scientists	Motoyo Itoh Arctic Ocean Climate System Research, Research Institute for Global Change, Japan Agency for Marine-Earth Science and Technology (RIGC/JAMSTEC)

Representatives of the Science Parties and Titles of the Proposals

- Atsushi Yamaguchi (Hokkaido University)
"Spatial and vertical distribution of phyto- and zoo-plankton in the Arctic Ocean" (leg 2)
- Toru Hirawake (Hokkaido University)
"Response of phytoplankton community to the western Arctic Ocean warming (leg 2)
- Naomi Harada (JAMSTEC)
"Study on Biogeochemistry in the Arctic Ocean" (leg1-2)
- Ippei Nagao (Nagoya University)
"Sea-air flux measurements of marine biogenic gas (dimethylsulfide) by eddy correlation method" (leg 1)
- Fumiyoshi Kondo (The University of Tokyo)
"Behavior of Chemicals and Air-Sea Physical Flux in Sea Fog" (leg 1-2)
- Masao Uchida (National Institute for Environmental Studies)
"Reconstruction of marine environment in the Arctic Ocean during the last deglaciation and early Holocene" (leg 2)
- Motoo Utsumi (University of Tsukuba)
"Relationship between marine bacterial community structures, its growth characteristics and marine carbon cycling in the Arctic Ocean" (leg 1-2)
- Kazuma Aoki (University of Toyama)
"Maritime aerosol optical properties from measurements of Ship-borne sky radiometer" (leg 1-2)
- Michio Aoyama (Meteorological Research Institute / Japan Meteorological Agency)
"A study on long term behavior of nutrients in sea water" (leg 2)
- Osamu Tsukamoto (Okayama University)
"On-board continuous air-sea eddy flux measurement" (leg 1-2)
- Hisahiro Takashima (JAMSTEC)
"Tropospheric aerosol and gas profile observations by MAX-DOAS on a research vessel" (leg 1-2)
- Naoyuki Kurita (JAMSTEC)
"Water sampling for building water isotopologue map over the Ocean" (leg 1-2)

Nobuo Sugimoto (National Institute for Environmental Studies)

“Lidar observations of optical characteristics and vertical distribution of aerosols and clouds” (leg 1-2)

Takeshi Matsumoto (University of the Ryukyus)

“Standardising the marine geophysics data and its application to the ocean floor geodynamics studies” (leg 1-2)

Cruise Periods and Ports of Call

Leg 1: August 24, 2010 – September 1, 2010
(Sekinehama – Hachinohe · Dutch Harbor)

Leg 2: September 2, 2010 – October 16, 2010
(Dutch Harbor – Dutch Harbor)

Research Areas Arctic Ocean, Bering Sea, and North Pacific Ocean

Overview of MR10-05 activities

CTD/LADCP:	178 casts (at 177 points)
CTD/Water Samplings:	132 casts
XCTD:	168 casts
Radiosonde:	215 points
Mooring Deployment:	6 stations
Surface Drifting Buoy deployments:	3 stations
Turbulence Ocean Microstructures:	30 casts
Bio-optical measurements:	31 stations
Plankton Nets:	63 stations
Piston Cores:	5 casts (at 4 points)
Multiple Cores:	11 casts
Shipboard ADCP:	Continuous Observation
Sea Surface Water Monitoring System:	Continuous Observation
Meteorological Observation System:	Continuous Observation
Doppler Rador:	Continuous Observation
Aerosol sampling:	Continuous Observation
Sky Radiometer:	Continuous Observation
Multi-Axis Differential Optical Absorption Spectroscopy (MAX-DOAS):	Continuous Observation
Dual Polarization Lidar:	Continuous Observation
Eddy Flux Measurement System:	Continuous Observation
DMS Continuous Measurement:	Continuous Observation(Leg1)
Seabeam:	Continuous Observation
Geophysical Continuous Observation (Magnetometer, Gravity meter):	Continuous Observation

1.2. Cruise track

MR10-05 Cruise Track

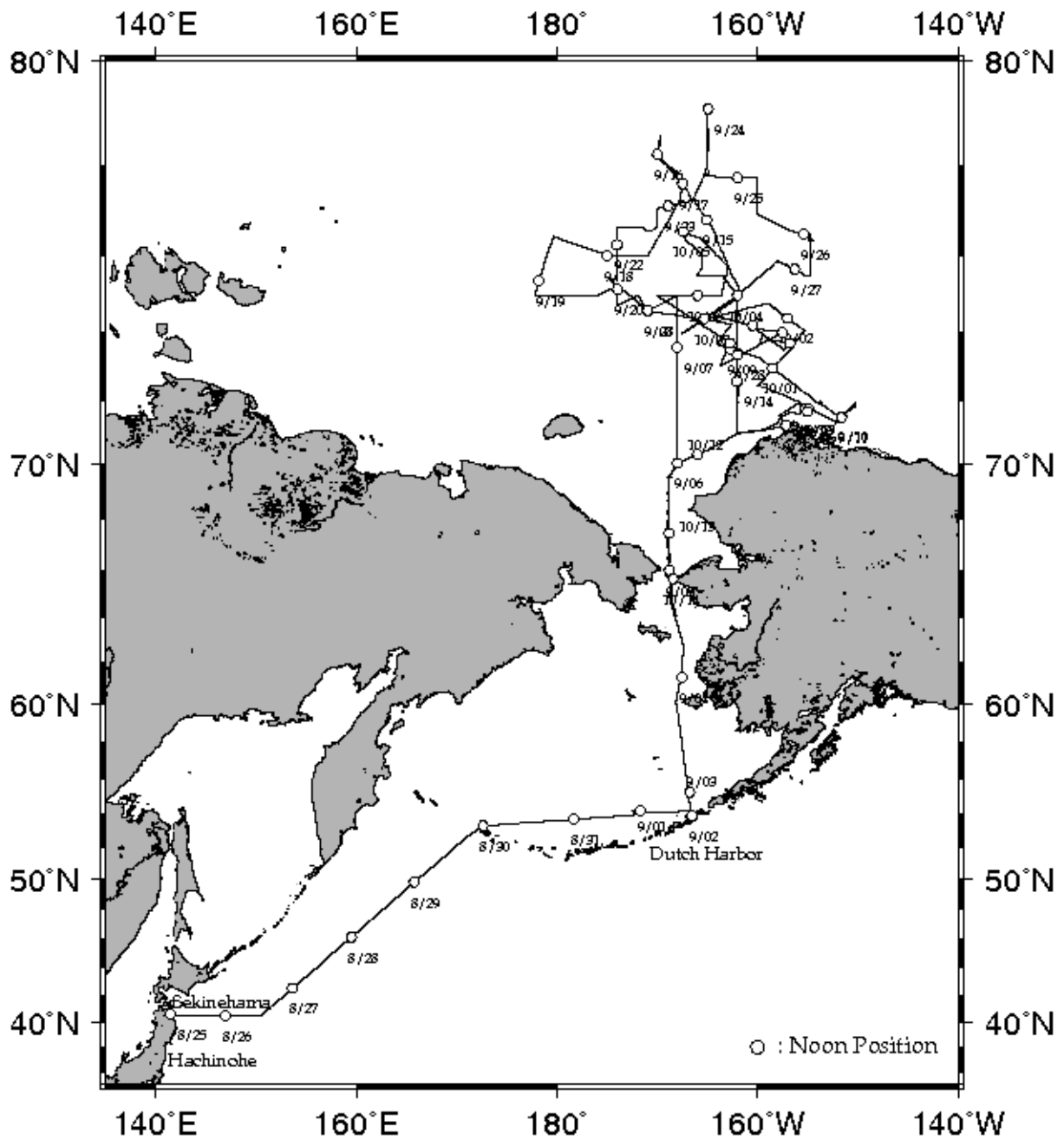

MR10-05 Cruise Track

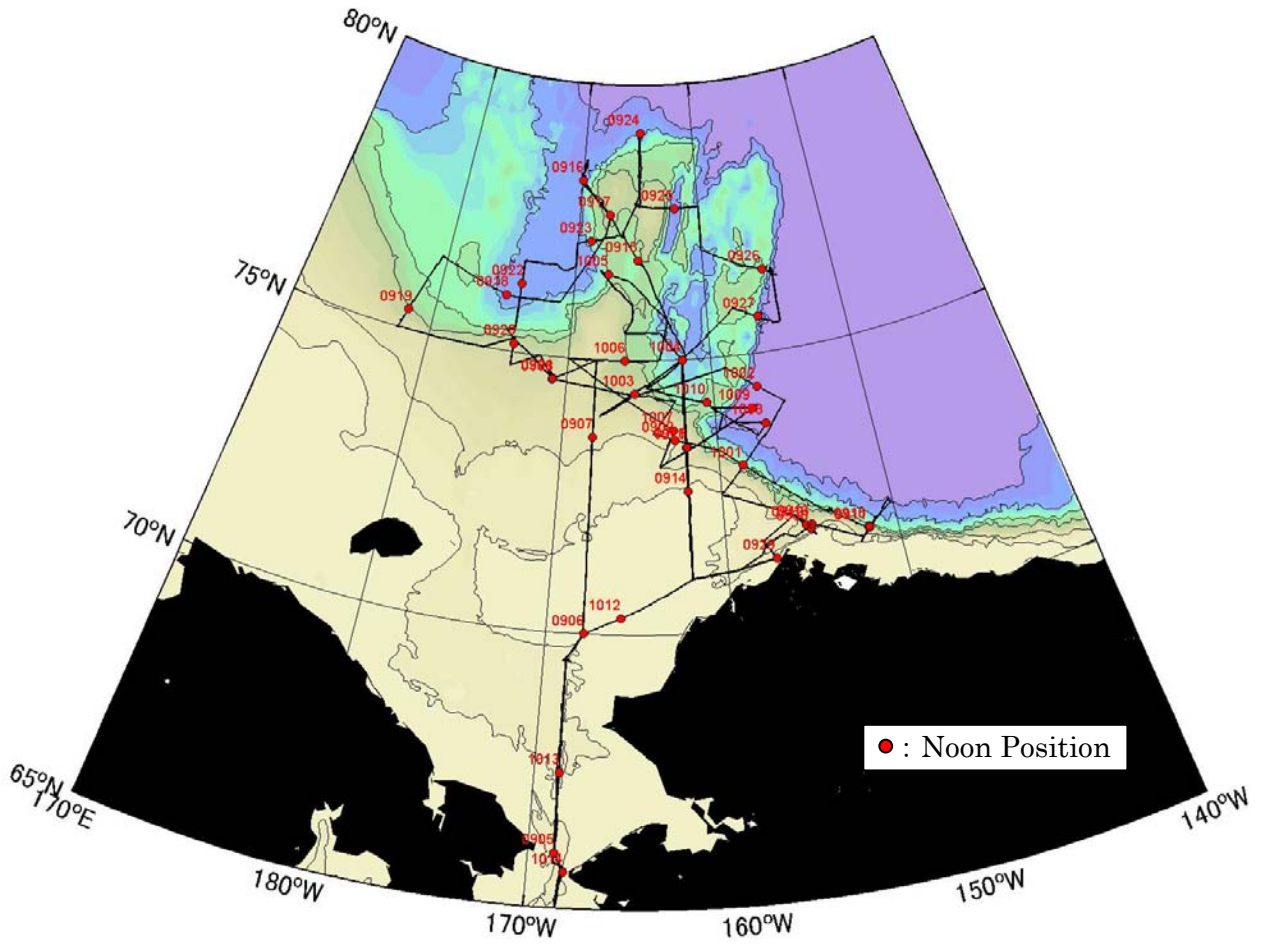

1.3. List of Participants

List of Participants for leg1

NO	NAME	ORGANIZATION	POSITION
1	Motoyo Itoh	JAMSTEC, RIGC	Research Scientist
2	Shigeto Nishino	JAMSTEC, RIGC	Research Scientist
3	Kohei Matsuno	Hokkaido University	Graduate Student
4	Amane Fujiwara	Hokkaido University	Graduate Student
5	Chie Sato	Tsukuba University	Graduate Student
6	Shohei Akiyama	Tsukuba University	Graduate Student
7	Manami Sato	Tsukuba University	Research Scientist
8	Tetsuya Shinozaki	Tsukuba University	Graduate Student
9	Stephan Rella	National Institute for Environmental Studies	Postdoctoral Scientist
10	Fumiyoshi Kondo	The University of Tokyo	Research Scientist
11	Ippe Nagao	Nagoya University	Assistant Professor
12	Satoshi Ozawa	Marine Works Japan Ltd.	Senior Technical Staff
13	Tomohide Noguchi	Marine Works Japan Ltd.	Technical Staff
14	Fuyuki Shibata	Marine Works Japan Ltd.	Technical Staff
15	Kanako Yoshida	Marine Works Japan Ltd.	Technical Staff
16	Kimiko Nishijima	Marine Works Japan Ltd.	Technical Staff
17	Kazuho Yoshida	Global Ocean Development Inc.	Senior Technical Staff

List of Participants for leg2

NO	NAME	ORGANIZATION	POSITION
1	Motoyo Itoh	JAMSTEC, RIGC	Research Scientist
2	Shigeto Nishino	JAMSTEC, RIGC	Research Scientist
3	Jun Inoue	JAMSTEC, RIGC	Senior Scientist
4	Yusuke Kawaguchi	JAMSTEC, RIGC	Postdoctoral Scientist
5	Kazutoshi Sato	JAMSTEC, RIGC / Hirosaki University	Student
6	Robert Rember	International Arctic Research Center (IARC)	Research Professional
7	Kohei Matsuno	Hokkaido University	Graduate Student
8	Amane Fujiwara	Hokkaido University	Graduate Student
9	Jonaotaro Onodera	JSPS / JAMSTEC, RIGC	Postdoctoral Scientist
10	Manami Sato	Tsukuba University	Research Scientist
11	Chie Sato	Tsukuba University	Graduate Student
12	Shohei Akiyama	Tsukuba University	Graduate Student
13	Tetsuya Shinozaki	Tsukuba University	Graduate Student

14	Stephan Rella	National Institute for Environmental Studies	Postdoctoral Scientist
15	Fumiyoshi Kondo	The University of Tokyo	Research Scientist
16	Kenichiro Sato	Marine Works Japan Ltd.	Senior Technical Staff
17	Miyo Ikeda	Marine Works Japan Ltd.	Technical Staff
18	Kanako Yoshida	Marine Works Japan Ltd.	Technical Staff
19	Satoshi Ozawa	Marine Works Japan Ltd.	Technical Staff
20	Horokatsu Uno	Marine Works Japan Ltd.	Technical Staff
21	Tomohide Noguchi	Marine Works Japan Ltd.	Technical Staff
22	Tatsuya Tanaka	Marine Works Japan Ltd.	Technical Staff
23	Shinsuke Toyoda	Marine Works Japan Ltd.	Technical Staff
24	Fuyuki Shibata	Marine Works Japan Ltd.	Technical Staff
25	Minoru Kamata	Marine Works Japan Ltd.	Technical Staff
26	Masanori Enoki	Marine Works Japan Ltd.	Technical Staff
27	Yoshiko Ishikawa	Marine Works Japan Ltd.	Technical Staff
28	Kimiko Nishijima	Marine Works Japan Ltd.	Technical Staff
29	Jyunji Matsuhita	Marine Works Japan Ltd.	Technical Staff
30	Ayaka Hatsuyama	Marine Works Japan Ltd.	Technical Staff
31	Masahiro Orui	Marine Works Japan Ltd.	Technical Staff
32	Misato Kuwahara	Marine Works Japan Ltd.	Technical Staff
33	Ai Takano	Marine Works Japan Ltd.	Technical Staff
34	Hiroyasu Sato	Marine Works Japan Ltd.	Technical Staff
35	Yusuke Sato	Marine Works Japan Ltd.	Technical Staff
36	Yasushi Hashimoto	Marine Works Japan Ltd.	Technical Staff
37	Yuki Miyajima	Marine Works Japan Ltd.	Technical Staff
38	Hatsumi Aoyama	Marine Works Japan Ltd.	Technical Staff
39	Norio Nagahama	Global Ocean Development Inc.	Senior Technical Staff
40	Satoshi Okumura	Global Ocean Development Inc.	Technical Staff
41	Soichiro Sueyoshi	Global Ocean Development Inc.	Technical Staff
42	Asuka Doi	Global Ocean Development Inc.	Technical Staff

2. Meteorological Observation

2.1. GPS Radiosonde

(1) Personnel

Jun Inoue	(JAMSTEC) Principal Investigator
Kazutoshi Sato	(JAMSTEC / Hirosaki University)
Norio Nagahama	(GODI)
Satoshi Okumura	(GODI)
Souichiro Sueyoshi	(GODI)
Asuka Doi	(GODI)
Wataru Tokunaga	(MIRAI Crew)

(2) Objectives

To understand the thermodynamic structure of boundary layers, cyclones, and high pressure systems, 6-hourly (3-hourly during intensive observation period) radiosonde observations were conducted over the Arctic Ocean from 5 September 2010 to 13 October 2010. The obtained data will be used for studies of clouds, validation of reanalysis data, and data assimilation. Because meteorological data over the Arctic Ocean is very few due to lack of regular meteorological stations, our upper atmospheric data must be vital for weather predictions and atmospheric reanalysis to provide more accurate atmospheric structure.

(3) Parameters

Atmospheric soundings of temperature, humidity, and wind speed/direction.

(4) Instruments and Methods

Radiosonde observations were carried out from 5 September to 12 October 2010, by using GPS radiosonde (RS92-SGPD). We used DigiCORA III (MW21), GPS antenna (GA20), UHF antenna (RB21) and balloon launcher (ASAP) made by Vaisala. Prior to launch, humidity, air temperature, and pressure sensors were calibrated by using the calibrator system (GC25 and PTB220, Vaisala). Measured parameters are temperature (degC), relative humidity (%), wind direction (deg), wind speed (m/s), air pressure (hPa).

(5) Station list

Table 2.1-1 summarizes the log of upper air soundings. All data were sent to the world meteorological community by the global telecommunication system (GTS)

through the Japan Meteorological Agency immediately after each observation. Raw data was recorded as binary format during ascent. ASCII data was converted from raw data.

(6) Preliminary results

GPS radio sondes were launched from 06UTC 5 September to 12UTC 13 October 2010 (Figure 2-2-1, Table 2.1-1). We basically launched them 4 times a day (00, 06, 12, and 18UTC). In addition to this, 3-hourly observations were set up during 162W line section (from 71N to 75N) on 13-14 Sep, 27-28 Sep, and 10-11 Oct. Extra 3-hourly observations were also done when synoptic disturbances were approached.

Time-height section of observed air temperature, time series of sea and air surface temperatures, and GPS positions of launching are shown in Figure 2.1.2. The former period is characterized by warm advection over Chukchi Sea where the strong pressure gradient between the synoptic low pressure systems over the East Siberian Sea and high pressure system over the Beaufort Sea. Inversion layers were frequently observed in this period.

On 23 September 2010, we reached at the northernmost positions at 79.18N. After this day, a low pressure system was passed over the R/V Mirai. The wind direction changed from SE-ly warm wind to NW-ly cold wind. The height of tropopause was dropped from 11 km to 5 km.

After this event, air temperatures at the surface and 500hPa were recorded below freezing and around -40°C , suggesting the coming of winter season.

(7) Data Archive

All datasets obtained in this cruise will be submitted to the Data Integration and Analysis Group (DIAG) of JAMSTEC, and will be opened to the public via "R/V MIRAI Data Webpage" in JAMSTEC web site.

(8) Remark

RS166 observation has no wind data, because of the trouble on receiving GPS signal via GA20.

Table 2.1-1. Launch log

ID	Date	Latitude	Longitude	Psfc	Tsfc	RHsfc	WD	Wsp	SST	Max height		Cloud	
	YYYYMMDDHH	degN	degE	hPa	degC	%	deg	m/s	degC	hPa	m	Amount	Type
RS001	2010090506	66.964	-168.841	996.4	9.0	99	46	6.1	8.242	48.5	21013	10	St
RS002	2010090512	68.001	-168.836	1000.0	8.9	98	28	5.5	7.467	26.1	25027	10	St
RS003	2010090518	69.002	-168.844	1002.7	7.4	100	19	9.6	7.954	34.4	23218	8	St
RS004	2010090600	69.994	-168.000	1005.4	6.1	100	40	7.4	6.815	33.2	23459	10	St
RS005	2010090603	70.002	-168.011	1006.4	5.8	100	39	3.0	7.348	25.8	25129	10	St
RS006	2010090606	70.499	-167.996	1007.8	4.1	100	65	4.3	5.908	32.9	23531	10	St
RS007	2010090609	71.000	-168.003	1009.6	4.2	100	87	4.5	6.342	30.3	24055	10?	St?
RS008	2010090612	71.487	-168.028	1010.2	3.9	100	117	7.1	6.098	35.5	23037	10	St
RS009	2010090615	72.001	-167.997	1010.6	3.7	100	100	6.3	5.767	32.2	23644	7	St
RS010	2010090618	72.479	-167.990	1011.5	3.2	100	106	6.3	5.002	31.2	23868	8	St,Ac,Ci
RS011	2010090621	73.000	-168.006	1011.6	3.0	100	96	6.8	3.345	29.5	24251	7	St,Ac
RS012	2010090700	73.494	-168.030	1012.1	2.1	100	85	4.0	2.266	44.2	21646	3	Cs,Ci,Ac,As
RS013	2010090703	74.002	-168.006	1011.8	2.1	100	93	6.7	2.309	32.3	23654	8	St
RS014	2010090706	74.468	-167.996	1011.9	2.3	100	100	6.2	2.441	31.2	23854	10	St
RS015	2010090709	74.999	-168.002	1012.0	1.7	100	115	10.1	1.041	28.9	24360	10	St
RS016	2010090712	74.802	-169.455	1010.6	1.3	100	103	7.4	1.380	34.7	23184	6	Ac,Sc,St
RS017	2010090718	74.602	-170.941	1007.5	1.7	100	106	6.9	0.732	41.7	21976	10	St
RS018	2010090800	74.606	-170.994	1006.5	1.7	100	96	6.0	0.679	45.6	21423	10	St
RS019	2010090806	74.524	-168.988	1006.8	1.9	100	124	8.2	1.862	51.2	20650	10	St
RS020	2010090812	74.318	-164.035	1007.0	2.0	100	69	6.3	3.550	43.0	21802	10	St
RS021	2010090818	74.050	-163.997	1006.0	2.1	100	88	8.5	3.174	42.0	21939	10	St
RS022	2010090900	73.596	-163.221	1006.6	2.6	100	104	2.5	2.976	27.5	24695	10	St
RS023	2010090906	73.087	-158.914	1007.5	2.2	100	357	2.7	3.666	39.5	22330	10	St
RS024	2010090912	72.250	-155.261	1009.6	2.3	100	312	4.1	5.474	31.7	23749	10	St
RS025	2010090918	71.955	-153.778	1011.9	2.8	100	314	5.2	7.011	50.9	20685	10	St
RS026	2010091000	71.520	-151.715	1014.3	2.7	100	273	6.3	3.650	33.2	23449	10	St
RS027	2010091006	71.374	-152.064	1016.1	1.9	100	297	4.8	3.500	81.1	17705	10	St
RS028	2010091012	71.944	-150.247	1016.8	2.4	100	304	4.1	4.703	31.6	23735	10	St
RS029	2010091018	71.829	-150.655	1017.9	1.7	100	30	2.5	4.567	27.8	24577	9	St
RS030	2010091100	71.501	-151.657	1018.2	2.4	100	67	0.2	3.678	36.1	22904	10	St
RS031	2010091106	71.371	-152.155	1017.6	1.7	100	133	3.7	3.458	29.7	24128	10	St
RS032	2010091112	71.735	-155.229	1016.0	3.1	99	134	6.0	4.617	31.6	23725	8	St
RS033	2010091118	71.729	-155.162	1015.4	2.7	100	135	6.9	5.056	32.4	23572	9	St
RS034	2010091200	71.674	-154.995	1014.6	3.6	100	137	6.1	8.046	31.8	23694	4	St,Ci
RS035	2010091206	71.796	-155.330	1014.2	6.7	99	240	4.1	4.655	37.3	22644	10	St,Ac,Ns

RS036	2010091212	71.791	-155.314	1014.5	7.0	100	194	5.8	4.634	54.0	20255	10	As,St
RS037	2010091218	71.794	-155.336	1014.7	7.0	98	238	9.5	4.534	27.9	24507	10	Ac,As,St
RS038	2010091300	71.755	-154.979	1014.5	6.8	100	245	9.2	5.182	44.4	21562	10	St
RS039	2010091306	71.529	-157.633	1018.5	6.5	99	236	5.7	5.047	28.7	24309	5	Ac,St
RS040	2010091312	71.082	-159.889	1019.9	8.0	98	151	4.5	5.830	52.6	20478	10	St,As
RS041	2010091315	70.999	-161.998	1019.2	8.4	96	129	6.4	7.448	45.4	21424	6	As,St
RS042	2010091318	71.480	-161.998	1019.8	5.7	99	111	6.0	4.550	26.9	24778	9	As,St,Cs
RS043	2010091321	72.001	-161.996	1020.2	5.5	99	107	8.4	4.517	34.5	23188	10	St,Sc
RS044	2010091400	72.483	-161.982	1020.8	5.1	100	109	10.1	4.466	32.1	23649	10	St
RS045	2010091403	72.999	-161.997	1021.0	4.1	100	104	8.4	3.633	28.0	24523	10	St
RS046	2010091406	73.524	-161.986	1021.3	3.8	100	109	10.5	4.113	99.2	16444	10	St
RS047	2010091409	74.003	-161.997	1021.7	2.4	100	113	15.7	1.840	34.7	23138	10	St?
RS048	2010091412	74.480	-161.957	1022.9	2.1	100	115	14.2	3.068	32.3	23576	10	St
RS049	2010091415	74.985	-161.966	1022.2	1.5	100	117	15.7	2.899	32.3	23565	10	St
RS050	2010091418	75.436	-162.356	1021.8	1.1	96	125	19.9	2.216	58.3	19794	10	St
RS051	2010091421	76.070	-163.460	1022.3	0.6	100	121	14.7	1.814	31.0	23843	10	St
RS052	2010091500	76.707	-164.655	1021.9	0.1	100	120	13.6	0.711	32.0	23620	10	St
RS053	2010091503	77.207	-166.153	1020.3	0.1	99	124	14.2	0.442	30.1	24018	10	St
RS054	2010091506	77.744	-167.948	1019.7	-0.4	100	123	13.8	-0.780	38.9	22365	10	St
RS055	2010091512	77.885	-168.079	1018.6	-0.4	100	114	11.3	-0.790	182.2	12351	10	St
RS056	2010091518	78.272	-169.859	1015.8	-0.3	100	126	8.8	-1.264	27.2	24651	10	St
RS057	2010091600	78.283	-170.012	1013.4	-0.5	100	123	15.1	-1.250	31.4	23720	10	St
RS058	2010091606	78.226	-169.842	1010.0	-0.6	100	97	2.1	-1.231	44.8	21416	10	St
RS059	2010091612	78.243	-169.936	1009.7	-0.7	100	158	3.0	-1.240	33.1	23345	10	St
RS060	2010091618	78.073	-169.343	1010.7	-0.9	100	265	5.0	-1.149	34.8	23026	9	As,Cc
RS061	2010091700	77.631	-167.483	1014.8	-0.8	100	262	5.7	-0.848	22.1	25959	5	St,As,Cc,Ci
RS062	2010091706	76.748	-169.099	1017.4	-1.0	100	228	5.6	-0.928	35.7	22880	9	St,As
RS063	2010091712	76.000	-172.525	1019.4	-1.5	100	216	7.3	-0.712	50.4	20674	10	St
RS064	2010091718	76.002	-175.249	1018.2	-0.8	100	126	7.4	-0.767	36.5	22740	5	As,Ci,Cc
RS065	2010091721	76.004	-175.259	1017.3	-1.0	100	128	11.2	-0.827	33.3	23317	10	St,Sc
RS066	2010091800	76.001	-175.001	1015.6	-0.7	100	114	14.7	-0.735	29.6	24087	10	St
RS067	2010091803	76.010	-174.008	1013.2	0.0	100	120	12.8	-0.721	27.5	24564	10	St
RS068	2010091806	76.222	-177.613	1008.2	0.1	100	107	12.2	-0.823	30.9	23801	10	St
RS069	2010091809	76.413	-179.959	1004.6	0.2	100	131	9.6	-0.911	29.6	24060	10	St
RS070	2010091812	76.446	179.697	1003.1	0.1	100	157	7.1	-0.806	46.5	21173	10	St,As
RS071	2010091815	76.311	179.428	1002.1	1.3	98	168	8.8	-0.828	35.1	22960	7	As,St,Ac
RS072	2010091818	76.001	178.906	1002.7	0.2	100	194	10.2	-0.705	45.3	21324	10	St
RS073	2010091821	75.580	178.419	1005.2	-1.1	100	222	17.2	-0.501	42.3	21787	10	St

RS074	2010091900	75.406	178.214	1007.7	-0.4	100	236	11.5	-0.604	36.9	22663	10	St
RS075	2010091903	75.139	177.908	1011.3	0.3	96	240	16.6	0.010	69.4	18559	10	St,Sc
RS076	2010091906	74.997	177.824	1015.3	0.3	93	239	11.6	-0.086	37.3	22569	10	St,Sc
RS077	2010091912	74.993	-179.173	1019.7	0.1	95	254	10.0	-0.068	40.6	22034	7	As,Sc,St
RS078	2010091918	75.000	-176.009	1021.7	-0.4	94	268	10.7	0.240	36.0	22807	10	As
RS079	2010092000	75.243	-174.018	1023.3	0.1	95	187	10.0	0.278	32.0	23565	10	St,Sc,As
RS080	2010092006	74.911	-173.733	1024.0	-0.4	97	339	7.4	0.797	29.6	24044	10	As,Sc
RS081	2010092012	74.645	-171.039	1025.2	-0.9	97	356	4.0	1.476	38.8	22326	10	St
RS082	2010092018	74.599	-170.999	1024.9	-0.4	97	49	4.3	1.780	31.4	23673	10	As
RS083	2010092100	74.602	-170.998	1025.1	0.5	93	73	5.6	1.774	31.1	23693	10	As,Sc
RS084	2010092106	75.118	-173.282	1025.5	-0.1	96	91	9.4	0.386	48.3	20888	10	As,Sc
RS085	2010092112	75.408	-174.102	1025.3	-0.6	92	86	7.6	-0.389	33.4	23242	10	As,Sc
RS086	2010092118	75.813	-174.011	1026.1	-0.8	93	106	7.2	-0.471	34.3	23501	9	As,Ac
RS087	2010092200	76.253	-173.992	1026.5	-1.2	89	105	8.0	-0.896	34.8	22950	10	As,Sc
RS088	2010092206	76.668	-173.742	1026.0	-1.5	99	100	9.2	-0.927	25.7	24872	10	St
RS089	2010092212	76.654	-171.354	1025.3	-1.3	88	102	8.6	-0.981	65.8	18836	10	As,St
RS090	2010092218	77.083	-170.000	1024.5	-2.0	100	121	4.8	-1.093	32.2	23403	9	St,As,Cc,Ci
RS091	2010092300	77.143	-168.933	1022.5	-2.1	98	128	10.6	-1.027	29.3	24001	10	St
RS092	2010092303	77.176	-168.384	1020.8	-2.3	98	119	8.3	-0.750	29.8	23883	10	St
RS093	2010092306	77.240	-167.063	1019.9	-1.4	99	155	4.8	0.263	72.5	18161	10	St
RS094	2010092309	77.268	-166.322	1018.4	-0.8	99	161	8.8	0.118	63.5	19011	10	St
RS095	2010092312	77.795	-165.347	1017.3	-0.8	99	159	7.7	-0.161	33.8	23044	10	St,As
RS096	2010092315	78.265	-164.983	1015.1	-1.0	100	167	7.5	-1.031	39.7	22014	10	Ns
RS097	2010092318	78.708	-164.985	1012.3	-1.2	100	150	6.1	-1.323	29.2	23996	10	St
RS098	2010092321	79.125	-164.999	1009.9	-1.4	100	134	5.8	-1.385	29.6	23875	10	St
RS099	2010092400	79.191	-164.958	1006.9	-1.1	100	144	6.7	-1.397	38.6	22184	10	St
RS100	2010092403	78.957	-164.997	1003.8	-1.2	100	236	2.8	-1.305	34.4	22920	10	St
RS101	2010092006	78.867	-165.010	1002.5	-2.1	100	346	16.0	-1.307	55.4	19830	10	St
RS102	2010092009	78.593	-164.957	1003.3	-2.9	93	333	18.8	-1.110	32.6	23252	10	St
RS103	2010092412	77.800	-165.047	1005.4	-4.3	91	325	13.5	-0.089	89.4	16682	10	St
RS104	2010092415	77.841	-165.154	1005.4	-6.0	90	322	18.8	-0.158	54.8	19885	10	St
RS105	2010092418	77.838	-165.248	1004.2	-6.8	76	296	13.3	-0.158	36.5	22508	7	Sc,St
RS106	2010092421	77.763	-163.791	1000.4	-7.2	78	285	10.0	-0.435	34.3	22917	9	St, Sc
RS107	2010092500	77.759	-161.993	995.2	-6.2	87	253	9.0	-0.857	36.2	22565	7	St,Sc,As,Ac
RS108	2010092503	77.751	-161.961	992.4	-5.9	75	31	8.9	-0.983	38.1	22215	8	Sc,St
RS109	2010092506	77.768	-160.009	994.4	-5.9	71	70	8.9	-1.105	53.1	20060	1	Sc,St
RS110	2010092509	77.369	-160.037	995.7	-5.3	69	50	8.5	-1.155	38.9	22062	7	Sc,St
RS111	2010092512	76.975	-160.069	996.7	-5.4	68	17	6.9	-0.928	34.5	22839	7	Sc,St

RS112	2010092515	76.864	-159.121	997.0	-5.5	68	357	7.5	-0.938	40.0	21865	8	Sc,St
RS113	2010092518	76.700	-157.600	994.9	-3.9	96	330	14.0	-0.394	33.4	23037	10	St, As
RS114	2010092521	76.617	-157.052	995.6	-3.5	89	11	10.6	-0.349	39.3	22007	10	St, Sc
RS115	2010092600	76.509	-155.582	994.8	-4.2	92	356	14.6	0.382	38.2	22179	10	St,Sc
RS116	2010092603	76.380	-154.627	993.9	-4.3	89	0	16.2	-1.265	36.6	22424	10	St,Sc
RS117	2010092606	76.495	-154.813	993.5	-5.1	94	346	12.5	-1.249	34.7	22766	9	St,Sc
RS118	2010092609	76.392	-154.752	992.0	-4.2	92	348	13.3	-1.292	44.1	21235	10	St
RS119	2010092612	75.970	-154.741	991.7	-3.0	93	334	11.3	1.246	43.1	21347	10	St
RS120	2010092615	75.512	-155.266	992.5	-3.3	86	356	10.6	0.276	38.6	22086	10	Ns
RS121	2010092618	75.525	-155.327	993.1	-2.7	86	325	10.6	0.136	38.0	22188	10	Ns,As
RS122	2010092621	75.639	-156.176	993.6	-3.9	94	327	10.8	1.157	42.0	21538	10	St, Sc
RS123	2010092700	75.661	-156.294	994.1	-3.0	86	346	6.4	0.419	46.5	20880	10	St, Sc
RS124	2010092703	75.674	-156.487	994.6	-2.4	79	333	11.2	0.743	35.9	22538	9	St, Sc
RS125	2010092706	75.745	-157.112	994.7	-3.6	80	323	8.4	0.456	35.5	22601	10	Sc,St
RS126	2010092709	75.836	-158.217	995.4	-3.7	83	336	10.1	-0.450	46.3	20865	10	St, Sc
RS127	2010092712	75.445	-160.002	996.1	-3.6	77	326	10.9	0.488	43.9	21227	10	St,Sc
RS128	2010092715	75.026	-161.970	996.4	-3.0	87	340	14.1	0.633	41.6	21540	7	St,Ns
RS129	2010092718	74.531	-162.017	995.9	-3.3	85	325	9.2	1.244	33.8	22882	8	Sc,St,Ci,Ns
RS130	2010092721	74.034	-162.011	995.4	-2.9	89	312	12.0	1.463	46.3	20861	9	St, Sc, As
RS131	2010092800	73.551	-162.029	996.0	-2.6	88	331	9.3	2.336	38.9	22004	6	St, Sc, As
RS132	2010092803	73.020	-162.049	995.1	-1.9	83	310	10.6	2.220	40.3	21778	9	Ac,St,Sc
RS133	2010092806	72.551	-162.009	995.4	-2.1	86	312	10.2	2.932	39.0	21994	7	Sc,St
RS134	2010092809	72.036	-162.008	996.1	-1.8	88	300	10.7	3.422	43.0	21363	9	Sc,St
RS135	2010092812	71.539	-162.022	996.8	-1.0	77	308	14.8	3.015	34.1	22851	6	Sc,Ns
RS136	2010092815	71.015	-162.044	999.8	-1.1	79	316	11.0	3.182	42.9	21387	2	Ns,Cu, St
RS137	2010092818	71.022	-161.316	997.9	-0.8	79	308	9.1	2.946	39.5	21911	5	Cu,Sc,As,Ci
RS138	2010092900	71.207	-157.803	997.6	-0.4	73	275	7.0	3.161	33.4	23025	4	Ns,Sc,St,Ac
RS139	2010092906	71.496	-157.667	996.6	-1.0	85	251	5.6	3.001	33.8	22927	9	As,Ac,Sc,Ns
RS140	2010092912	71.874	-155.533	994.7	-2.3	100	24	4.7	1.976	36.7	22411	10	St
RS141	2010092918	71.811	-155.417	997.0	-1.7	75	354	2.6	3.179	36.5	22424	7	Cu,Ns,As,Ci,Cc
RS142	2010093000	71.733	-155.113	1000.0	-0.9	67	12	4.6	3.143	35.4	22635	3	Ci,Cc,Sc
RS143	2010093006	72.014	-156.009	1004.0	-1.5	65	65	6.4	2.447	45.7	20967	7	As,Sc
RS144	2010093012	72.357	-158.660	1008.3	-1.9	64	10	3.4	2.469	36.0	22486	6	Sc,As
RS145	2010093018	72.769	-159.139	1008.9	-1.8	63	281	8.5	1.815	38.4	22074	7	Sc
RS146	2010100100	73.000	-158.501	1008.3	-1.5	72	267	13.2	1.631	46.6	20819	7	As,Sc
RS147	2010100106	73.264	-157.677	1006.9	-0.5	74	273	12.3	1.307	39.9	21827	9	As,Sc
RS148	2010100112	73.488	-156.923	1006.7	-0.4	88	274	12.8	1.502	39.9	21825	5	St,Sc,Ns
RS149	2010100118	74.073	-155.328	1004.5	-0.2	94	267	13.4	0.377	34.0	22854	10	Sc,St,Ac

RS150	2010100200	74.399	-157.002	1005.6	-1.1	95	292	9.6	-0.480	36.7	22348	10	Sc,St
RS151	2010100206	74.678	-158.313	1005.5	-1.1	86	311	4.7	-0.151	34.5	22728	10	St,Sc
RS152	2010100212	74.672	-161.017	1006.5	-2.0	88	357	4.5	0.757	38.5	22003	8	St,As,Sc
RS153	2010100218	74.376	-165.247	1007.1	-1.6	91	327	4.0	0.874	49.1	20414	9	Sc,St,As
RS154	2010100300	74.379	-165.267	1007.5	-1.5	89	4	6.8	0.957	28.3	23937	6	Ac,Sc,Cu,Ci
RS155	2010100306	73.982	-167.599	1008.9	-1.2	80	21	4.0	0.625	33.3	22874	10	As,Sc,St
RS156	2010100312	74.515	-164.742	1010.6	-3.1	86	115	3.4	0.239	40.8	21579	2	Sc,St
RS157	2010100318	75.000	-162.005	1011.9	-3.4	80	110	5.8	-0.248	43.7	21118	9	Sc,St,As
RS158	2010100400	75.001	-161.994	1013.3	-3.5	86	122	3.1	-0.154	31.7	23161	10	Sc,St
RS159	2010100406	75.477	-163.418	1014.2	-2.6	79	137	4.9	-0.089	43.8	21081	10	Sc,St,As
RS160	2010100412	75.743	-165.479	1015.0	-2.5	87	169	4.7	0.097	38.7	21859	10	unknown
RS161	2010100418	76.243	-166.463	1016.0	-4.4	89	51	5.3	-0.797	47.7	20529	9	As, St, Sc
RS162	2010100421	76.623	-168.087	1016.8	-4.5	72	46	2.1	-1.403	37.2	22109	1	Sc
RS163	2010100500	76.569	-167.479	1016.9	-4.3	71	53	5.0	-0.628	44.6	20959	1	Sc
RS164	2010100503	76.517	-166.865	1016.9	-4.5	76	51	3.9	-1.001	36.9	22158	2	Sc,St,As
RS165	2010100506	76.419	-165.703	1017.1	-4.7	77	68	5.7	-0.807	55.6	19566	1	Sc,St
RS166	2010100509	76.016	-164.284	1016.6	-4.3	77	31	6.3	-0.336	95.2	16118	1	St,Sc
RS167	2010100512	75.820	-163.269	1016.3	-4.2	95	51	6.1	-0.666	40.4	21609	10	St
RS168	2010100515	75.699	-162.973	1015.9	-4.4	89	48	4.3	-0.488	36.8	22179	10	Ns, St
RS169	2010100518	75.149	-163.471	1015.0	-3.7	86	298	3.4	-0.452	38.7	21886	9	As,Sc,Ns
RS170	2010100600	74.995	-165.649	1013.8	-3.5	80	312	7.0	-0.386	35.8	22377	10	Sc,St
RS171	2010100606	75.001	-168.487	1014.7	-4.8	87	307	5.6	0.221	37.8	22022	10	Sc,St
RS172	2010100612	74.722	-168.407	1014.3	-3.7	81	323	3.0	-0.075	54.6	19682	6	St
RS173	2010100618	74.060	-164.643	1012.8	-3.2	85	303	6.3	0.605	41.0	21508	10	St
RS174	2010100700	73.713	-162.764	1011.7	-2.3	79	299	5.5	0.294	33.0	22894	2	Sc,St
RS175	2010100706	73.057	-163.752	1011.6	-2.5	79	325	5.4	0.710	52.1	19967	3	Sc,St,Ac
RS176	2010100712	73.480	-160.998	1010.1	-2.6	80	331	8.4	0.777	34.1	22680	10	St
RS177	2010100718	73.790	-159.002	1007.0	-1.5	95	316	7.8	-0.027	48.7	20368	10	St,Sc
RS178	2010100800	73.741	-157.295	1007.5	-5.1	85	8	7.1	0.297	45.3	20850	10	Sc,St
RS179	2010100806	73.626	-157.827	1008.0	-4.8	80	14	3.3	-0.218	39.7	21691	8	Sc,St
RS180	2010100812	73.745	-158.434	1005.9	-3.9	91	347	10.2	0.123	59.0	19118	10	St
RS181	2010100818	73.907	-159.222	1006.6	-5.8	83	14	8.3	0.153	59.6	19060	10	Sc
RS182	2010100821	74.102	-160.196	1007.7	-6.6	81	354	7.8	-0.169	32.0	23043	10	Sc, St, Ns
RS183	2010100900	74.037	-158.002	1007.5	-7.5	80	8	7.1	-0.276	35.6	22370	10	Sc,St
RS184	2010100903	74.017	-157.503	1007.9	-8.2	79	15	6.0	-0.110	37.9	21962	10	St,Sc
RS185	2010100906	74.015	-157.507	1008.0	-7.8	81	4	7.3	-0.121	77.8	17361	10	St
RS186	2010100909	73.916	-158.153	1008.3	-7.5	80	339	6.2	-0.304	43.1	21153	10	St
RS187	2010100912	73.873	-158.410	1008.7	-7.3	83	10	4.5	-0.435	41.4	21406	10	St

RS188	2010100915	73.714	-159.510	1008.9	-5.8	82	0	5.7	-0.399	41.1	21447	10	Ns,St
RS189	2010100918	73.809	-159.667	1009.6	-7.2	77	36	6.5	-0.293	47.8	20497	10	St
RS190	2010100921	73.987	-159.610	1011.1	-8.4	84	44	2.9	-0.194	52.8	19857	10	St, Ns
RS191	2010101000	74.186	-160.497	1012.4	-8.1	83	65	4.6	-0.172	47.7	20512	8	St,Ns
RS192	2010101003	74.335	-162.997	1013.4	-7.5	82	12	1.3	-0.015	47.0	20602	10	Sc
RS193	2010101006	74.501	-164.493	1014.2	-6.8	80	44	4.1	-0.525	47.5	20532	4	Sc
RS194	2010101009	74.623	-163.746	1014.4	-6.4	80	232	0.3	-0.652	49.0	20264	10	St
RS195	2010101012	74.752	-162.996	1014.0	-5.8	84	220	5.3	-0.798	47.0	20604	10	unknown
RS196	2010101015	74.988	-161.976	1013.2	-4.9	92	223	4.7	-1.035	41.4	21422	10	Ns
RS197	2010101018	74.503	-161.996	1013.8	-5.0	89	232	6.7	-0.718	41.6	21402	10	Ns
RS198	2010101021	74.000	-162.005	1014.5	-4.8	81	239	5.5	-0.583	51.6	20025	9	St, Ns, Ac
RS199	2010101100	73.516	-161.976	1015.3	-4.9	82	222	5.6	-0.334	44.9	20946	8	Ns,As,Ac
RS200	2010101103	72.999	-161.997	1016.1	-4.6	86	24	0.7	0.554	78.7	17326	10	Ac,As,Sc,St,Ns
RS201	2010101106	72.500	-161.997	1016.9	-4.5	76	90	2.5	1.231	41.7	21435	8	Ns,Ac
RS202	2010101109	72.036	-162.015	1017.1	-3.8	69	21	2.8	1.454	39.4	21795	2	Sc, St?
RS203	2010101112	71.523	-162.008	1017.3	-4.3	90	86	5.5	1.131	57.3	19391	8	Ac,St,Sc
RS204	2010101115	71.000	-161.999	1017.4	-4.1	78	130	6.2	1.338	39.3	21814	unkown	Ns
RS205	2010101118	70.879	-162.646	1017.8	-4.4	74	150	3.4	0.977	33.5	22853	9	Sc, St
RS206	2010101200	70.380	-165.493	1017.8	-3.5	65	123	5.1	3.712	55.8	19581	10	Sc
RS207	2010101206	69.774	-168.368	1016.6	-2.7	70	66	6.8	6.102	53.3	19874	10	Sc
RS208	2010101212	69.510	-168.684	1014.6	-2.0	72	59	10.9	5.898	47.6	20594	10	As
RS209	2010101218	68.500	-168.833	1011.3	-2.3	73	56	0.7	5.118	38.4	21997	9	Sc, Ns
RS210	2010101221	68.001	-168.834	1010.1	-1.6	74	220	1.1	2.897	40.8	21624	10	Sc
RS211	2010101300	67.527	-168.818	1008.8	0.4	72	170	10.9	4.683	46.7	20754	10	Sc
RS212	2010101303	67.000	-168.832	1007.2	0.4	88	170	14.6	3.965	42.5	21336	10	Sc, St
RS213	2010101306	66.554	-168.760	1006.2	1.0	99	162	13.5	3.508	48.0	20609	10	St
RS214	2010101309	66.450	-168.779	1004.9	2.3	98	167	14.5	3.200	46.7	20776	10	St
RS215	2010101312	66.313	-168.764	1004.2	3.0	100	169	14.4	3.200	46.6	20781	9	unknown

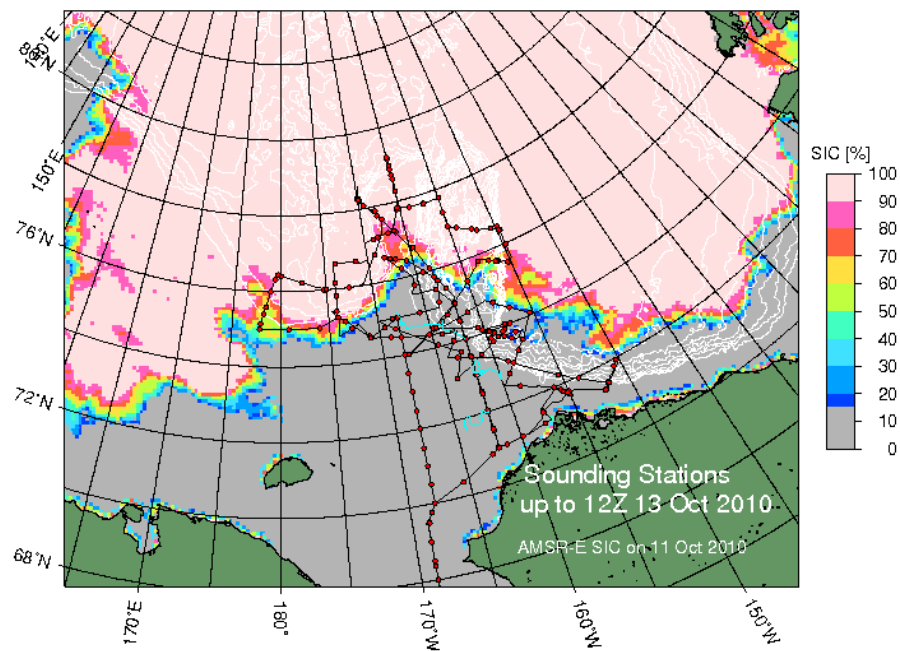

Figure 2.1-1. Map of sea ice distribution with radiosonde stations.

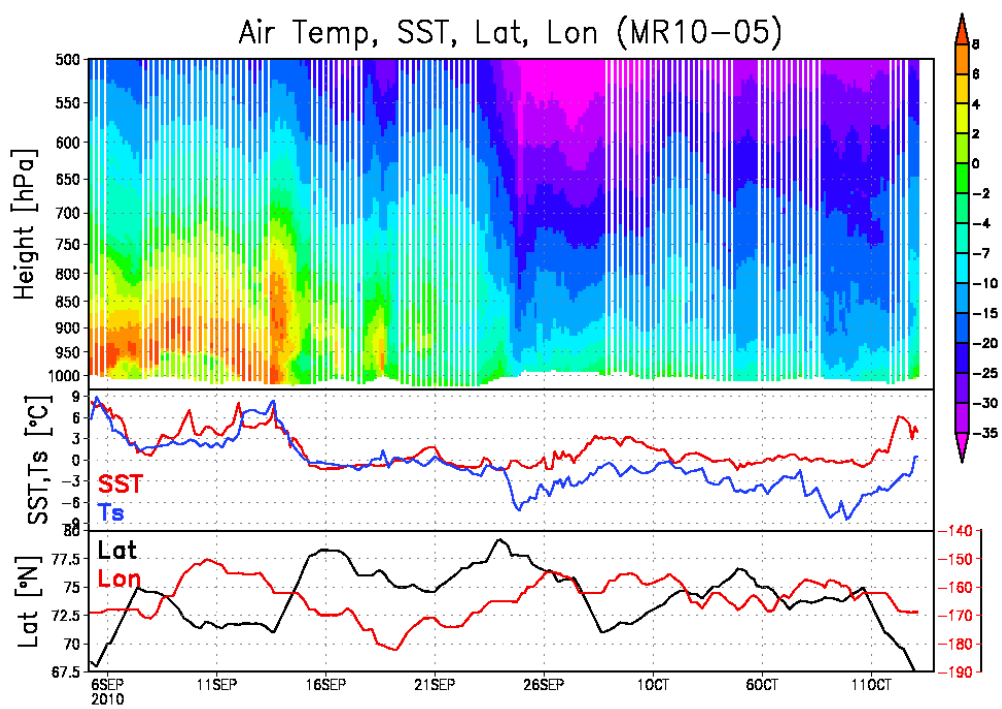

Figure 2.1-2. Time-height section of air temperature, and time series of sea (red) / air (blue) surface temperatures and GPS positions.

2.2. Doppler Radar

(1) Personnel

Jun Inoue	(JAMSTEC) Principal Investigator
Kazutoshi Sato	(JAMSTEC/Hirosaki University)
Norio Nagahama	(GODI)
Satoshi Okumura	(GODI)
Souichiro Sueyoshi	(GODI)
Asuka Doi	(GODI)
Wataru Tokunaga	(MIRAI Crew)

(2) Objective

Low level clouds over the Arctic Ocean which usually dominate during summer have a key role for sea/ice surface heat budget. In addition to this, cyclones which modify the sea-ice distributions are substantially important to understand the air-ice-sea interaction. To grasp the broad precipitation system over the Arctic Ocean, three dimensional radar echo structure and wind fields of rain/snow clouds was obtained by C-band Doppler radar observation.

(3) Parameters

C-band Doppler radar observed three dimensional radar echo structure and wind fields of rain/snow cloud.

(4) Instruments and Methods

The specifications of R/V MIRAI shipboard Doppler radar (RC-52B, Mitsubishi Electric Co. Ltd., Japan) are as follows.

Frequency:	5290MHz (C-band)
Beam Width:	better than 1.5 degrees
Transmit Power:	250kW (Peak Power)
Signal Processor:	RVP-7 (Vaisala Inc. Sigmet Product Line, U.S.A)
Inertial Navigation Unit:	PHINS (Ixsea SAS, France)
Application Software:	IRIS/Open Ver.8.05.10 (Vaisala Inc. Sigmet Product Line, U.S.A)

Measured parameters are Radar reflectivity factor (dBZ), Doppler velocity (m/s),

and velocity width (m/s). We checked transmitted frequency, mean output power and pulse repetition frequency (PRF) every day. The transmit pulse width and the receiver performance were checked before and after the observation.

(5) Observation log

The observation was performed throughout in the Arctic Ocean. During the observation, the volume scan consisting of 21 PPIs was conducted every 10 minutes. Meanwhile, a surveillance PPI scan was performed every 30 minutes. The parameters for above scans are listed in Table 2.2-1.

Start: 18:30 UTC 04 Sep. 2010
End: 00:00 UTC 14 Oct. 2010
Causal stop: 20:50 – 21:50 UTC 04 Sep. 2010
10:00 – 10:10 UTC 06 Sep. 2010
18:04 – 18:10 UTC 07 Sep. 2010
21:30 – 22:10 UTC 28 Sep. 2010
22:00 – 22:59 UTC 29 Sep. 2010
22:10 – 22:40 UTC 02 Oct. 2010
23:30 – 23:59 UTC 06 Oct. 2010
21:00 – 21:10 UTC 12 Oct. 2010

(6) Preliminary results

Persistent stratus clouds dominated below 1 km height during the former observation period (from 5 September to 13 September). Along the 162 W line on 14 September, we crossed a low pressure system which is a part of Arctic Dipole Anomaly. The echo top exceeded 8 km with southerly winds (Figure 2.2-1).

On 24 September, a developing low was observed, and cloud streets which consist of stratocumulus with snow shower was frequently observed behind a cold front on 28 September (Figure 2.2-2). Echo top increased from north (75N) to south (71N) due to the air mass modification over warm SST frontal zone.

(7) Data Archive

The raw data obtained in this cruise will be submitted to the Data Integration and Analysis Group (DIAG) of JAMSTEC.

(8) Remark

During the following period, data was not available.

06:54 (UTC) 12 Oct. 2010 – 07:15 (UTC) 12 Oct. 2010

Table 2.2-1. Selected parameters of C-band Doppler radar

	Surveillance PPI	Volume scan	RHI
Pulse width	2.0 [μ s]	0.5 [μ s]	
Scan speed	18 [deg/sec]		Automatic
PRF	260 [Hz]	900/720 [Hz]	
Sweep integration	32 samples	40 samples	
Ray spacing	about 1.0 [deg]		
Bin spacing	250 [m]		
Elevations	0.5	0.5, 1.0, 1.5, 2.1, 2.8, 3.5, 4.3, 5.1, 5.9, 6.8, 7.6, 8.5, 9.4, 10.4, 11.5, 12.7, 14.0, 15.5, 16.8, 18.8, 21.3	0.0 to 60.0
Azimuths	Full Circle		Optional
Range	300 [km]	160 [km]	
Software Filters	No filter	Dual-PRF velocity unfolding	
Gain control	Fixed		

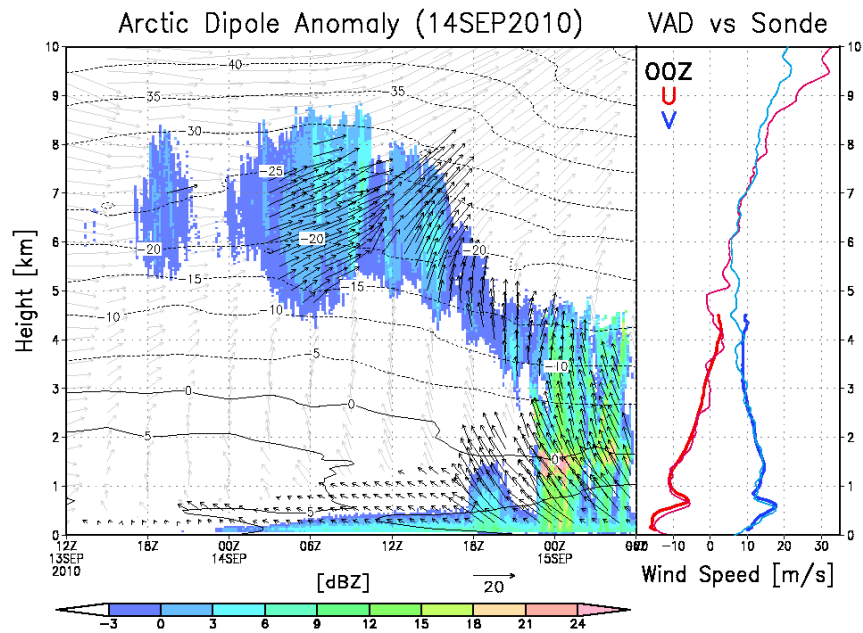

Figure 2.2-1. Left: Time-height cross section of radar reflectivity and VAD winds (black vectors). Contours and gray vectors indicate the air temperature and winds obtained by radiosonde observations. Right: Comparison of zonal (U) and meridional (V) wind components between radar-derived (thick) and radiosonde (thin) winds.

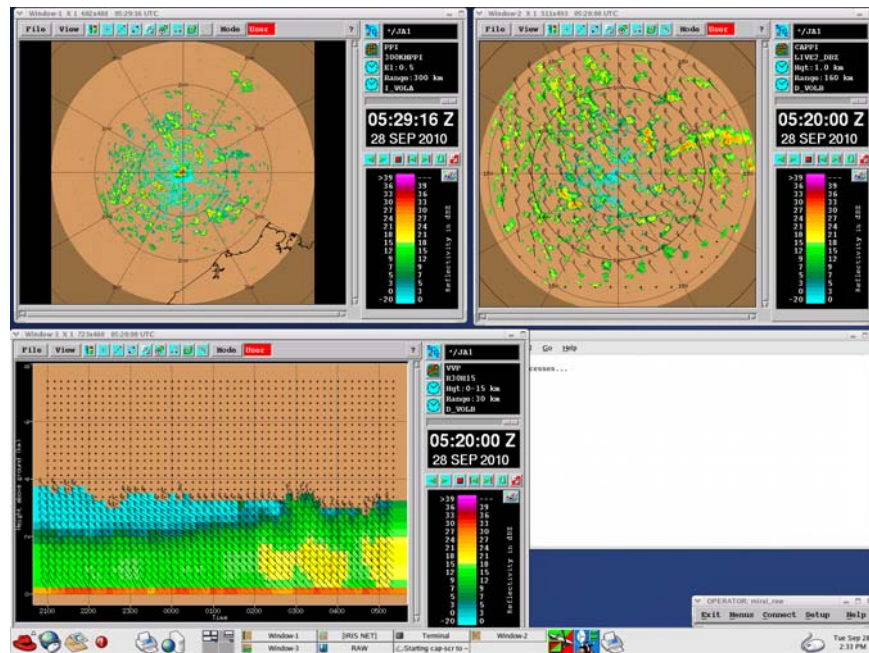

Figure 2.2-2. Screen shot of Doppler radar display on 28 September 2010.

2.3. Surface Meteorological Observation

(1) Personnel

Jun Inoue	JAMSTEC: Principal Investigator	
Kazuho Yoshida	Global Ocean Development Inc.: GODI	- Leg1 -
Norio Nagahama	GODI	- Leg2 -
Satoshi Okumura	GODI	- Leg2 -
Souichiro Sueyoshi	GODI	- Leg2 -
Asuka Doi	GODI	- Leg2 -
Wataru Tokunaga	MIRAI Crew	

(2) Objectives

Surface meteorological parameters are observed as a basic dataset of the meteorology. These parameters bring us the information about the temporal variation of the meteorological condition surrounding the ship.

(3) Methods

Surface meteorological parameters were observed throughout the MR10-05 cruise. During this cruise, we used three systems for the observation.

- i) MIRAI Surface Meteorological observation (SMet) system
- ii) Shipboard Oceanographic and Atmospheric Radiation (SOAR) system

i) MIRAI Surface Meteorological observation (SMet) system

Instruments of SMet system are listed in Table.2.3-1 and measured parameters are listed in Table.2.3-2. Data were collected and processed by KOAC-7800 weather data processor made by Koshin-Denki, Japan. The data set consists of 6-second averaged data.

ii) Shipboard Oceanographic and Atmospheric Radiation (SOAR) measurement system

SOAR system designed by BNL (Brookhaven National Laboratory, USA) consists of major three parts.

- a) Portable Radiation Package (PRP) designed by BNL - short and long wave downward radiation.
- b) Zeno Meteorological (Zeno/Met) system designed by BNL - wind, air temperature, relative humidity, pressure, and rainfall measurement.
- c) Scientific Computer System (SCS) developed by NOAA (National Oceanic and Atmospheric Administration, USA) - centralized data acquisition and logging of all data sets.

SCS recorded PRP data every 6 seconds, while Zeno/Met data every 10 seconds. Instruments and their locations are listed in Table.2.3-3 and measured parameters are listed in Table.2.3-4.

For the quality control as post processing, we checked the following sensors, before and after the cruise.

- i) Young Rain gauge (SMet and SOAR)

Inspect of the linearity of output value from the rain gauge sensor to change Input value by adding fixed quantity of test water.

ii) Barometer (SMet and SOAR)

Comparison with the portable barometer value, PTB220CASE, VAISALA.

iii) Thermometer (air temperature and relative humidity) (SMet and SOAR)

Comparison with the portable thermometer value, HMP41/45, VAISALA.

(4) Preliminary results

Figure 2.3-1 shows the time series of the following parameters;

Wind (SMet)

Air temperature (SMet)

Sea surface temperature (SMet)

Relative humidity (SMet)

Precipitation (SOAR, Optical rain gauge)

Short/long wave radiation (SOAR)

Pressure (SMet)

Significant wave height (SMet)

(5) Data archives

These meteorological data will be submitted to the Data Integration and Analysis Group (DIAG) of JAMSTEC just after the cruise.

(6) Remarks

i) SST (Sea Surface Temperature) data was available in the following periods.

07:36UTC 25 Aug. 2010 - 16:27UTC 01 Sep. 2010

18:43UTC 02 Sep. 2010 - 23:30UTC 15 Oct. 2010

ii) In the following period, SOAR true wind speed, true wind direction, gyro and LOG were invalid because they were not updated due to the network server trouble.

21:36UTC 30 Aug. 2010 - 22:14UTC 30 Aug. 2010

iii) In the following period, FRSR data acquisition was suspended to prevent damage to the shadow-band from freezing.

05:53UTC 16 Sep. 2010 - 01:22UTC 13 Oct 2010

iv) In the following period, SMet and SOAR anemometer were frozen. Wind speed and direction not available.

15 Sep. 2010 - 17 Sep 2010

v) In the following time, SMet rain gauge amount values were increased because of test transmitting for MF/HF radio.

10:24, 10:29, 23:12UTC 28 Aug. 2010

03:36, 03:39UTC 05 Sep. 2010

14:50UTC 13 Sep. 2010

15:05UTC 21 Sep. 2010

- vi) During the cruise, T/RH sensor was not in good condition. We replaced the T/RH sensor at 19:03UTC 10 Sep., due to the sensor trouble. Before changing the sensor, temperature was about -3 degrees lower than one of SMet, relative humidity was almost same as one of SMet. After changing the sensor, temperature had been about -0.3 degrees lower than one of SMet, relative humidity had been about -6% lower than one of SMet.
- vii) During the cruise, anemometer was not in good condition. Relative wind direction was about +7 degrees larger than one of SMet.
- viii) The following period, data was not available.
06:54UTC - 07:14UTC 12 Oct. 2010

Table.2.3-1

Instruments and installations of MIRAI Surface Meteorological observation system

Sensors	Type	Manufacturer	Location (altitude from surface)
Anemometer	KE-500	Koshin Denki, Japan	foremast (24 m)
Tair/RH	HMP45A	Vaisala, Finland	
with 43408 Gill aspirated radiation shield		R.M. Young, USA	compass deck (21 m) starboard side and port side
Thermometer: SST	RFN1-0	Koshin Denki, Japan	4th deck (-1m, inlet -5m)
Barometer	Model-370	Setra System, USA	captain deck (13 m) weather observation room
Rain gauge	50202	R. M. Young, USA	compass deck (19 m)
Optical rain gauge	ORG-815DR	Osi, USA	compass deck (19 m)
Radiometer (short wave)	MS-801	Eiko Seiki, Japan	radar mast (28 m)
Radiometer (long wave)	MS-200	Eiko Seiki, Japan	radar mast (28 m)
Wave height meter	MW-2	Tsurumi-seiki, Japan	bow (10 m)

Table.2.3-2

Parameters of MIRAI Surface Meteorological observation system

Parameter	Units	Remarks
1 Latitude	degree	
2 Longitude	degree	
3 Ship's speed	knot	Ship log, DS-30 Furuno
4 Ship's heading	degree	Ship gyro, TG-6000, Tokimec
5 Relative wind speed	m/s	6sec./10min. averaged
6 Relative wind direction	degree	6sec./10min. averaged
7 True wind speed	m/s	6sec./10min. averaged
8 True wind direction	degree	6sec./10min. averaged
9 Barometric pressure	hPa	adjusted to sea surface level 6sec. averaged
10 Air temperature (starboard side)	degC	6sec. averaged
11 Air temperature (port side)	degC	6sec. averaged
12 Dewpoint temperature (starboard side)	degC	6sec. averaged
13 Dewpoint temperature (port side)	degC	6sec. averaged
14 Relative humidity (starboard side)	%	6sec. averaged
15 Relative humidity (port side)	%	6sec. averaged
16 Sea surface temperature	degC	6sec. averaged
17 Rain rate (optical rain gauge)	mm/hr	hourly accumulation
18 Rain rate (capacitive rain gauge)	mm/hr	hourly accumulation
19 Down welling shortwave radiation	W/m ²	6sec. averaged
20 Down welling infra-red radiation	W/m ²	6sec. averaged
21 Significant wave height (bow)	m	hourly
22 Significant wave height (aft)	m	hourly
23 Significant wave period (bow)	second	hourly
24 Significant wave period (aft)	second	hourly

Table.2.3-3
Instruments and installation locations of SOAR system

<u>Sensors (Zeno/Met)</u>	<u>Type</u>	<u>Manufacturer</u>	<u>Location (altitude from surface)</u>
Anemometer	05106	R.M. Young, USA	foremast (26 m)
Tair/RH	HMP45A	Vaisala, Finland	
with 43408 Gill aspirated radiation shield		R.M. Young, USA	foremast (23 m)
Barometer	61202V	R.M. Young, USA	
with 61002 Gill pressure port		R.M. Young, USA	foremast (23 m)
Rain gauge	50202	R.M. Young, USA	foremast (25 m)
Optical rain gauge	ORG-815DA	Osi, USA	foremast (25 m)
<u>Sensors (PRP)</u>	<u>Type</u>	<u>Manufacturer</u>	<u>Location (altitude from surface)</u>
Radiometer (short wave)	PSP	Epply Labs, USA	foremast (25 m)
Radiometer (long wave)	PIR	Epply Labs, USA	foremast (25 m)
Fast rotating shadowband radiometer		Yankee, USA	foremast (25 m)

Table.2.3-4 Parameters of SOAR system

<u>Parameter</u>	<u>Units</u>	<u>Remarks</u>
1 Latitude	degree	
2 Longitude	degree	
3 SOG	knot	
4 COG	degree	
5 Relative wind speed	m/s	
6 Relative wind direction	degree	
7 Barometric pressure	hPa	
8 Air temperature	degC	
9 Relative humidity	%	
10 Rain rate (optical rain gauge)	mm/hr	
11 Precipitation (capacitive rain gauge)	mm	reset at 50 mm
12 Down welling shortwave radiation	W/m ²	
13 Down welling infra-red radiation	W/m ²	
14 Defuse irradiance	W/m ²	

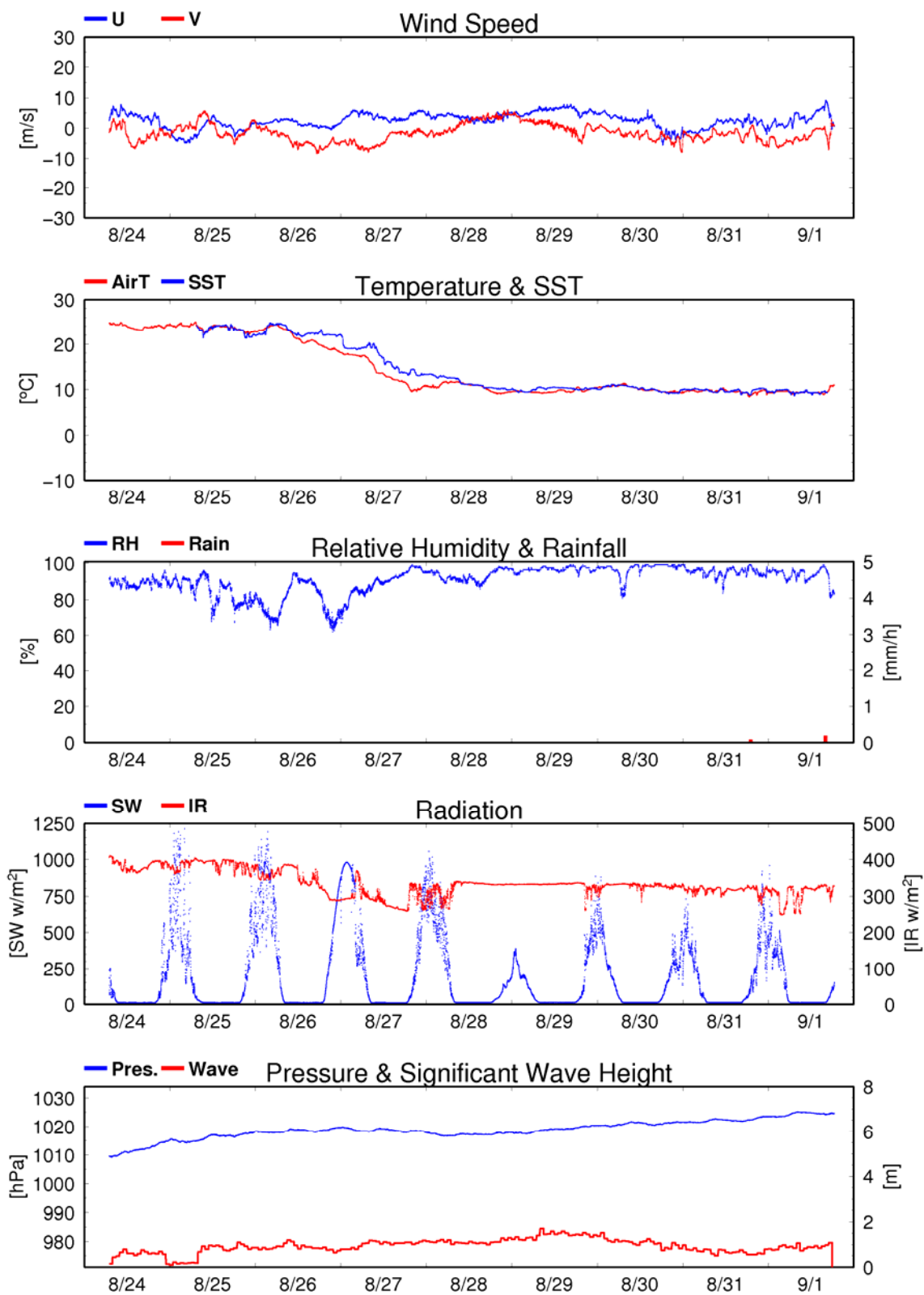

Fig.2.3-1

Time series of surface meteorological parameters throughout the MR10-05 cruise

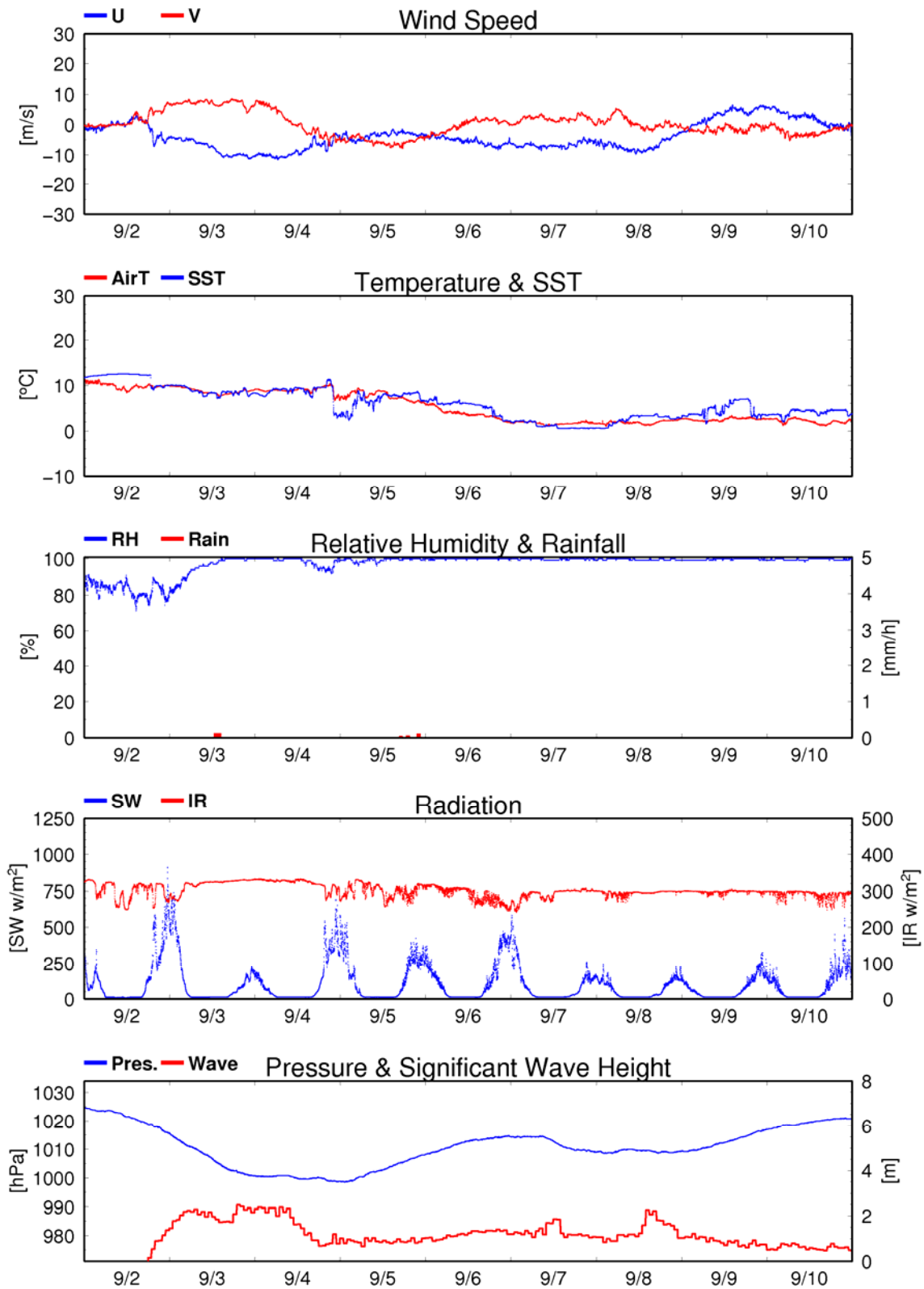

Fig. 2.3.1 (Continued)

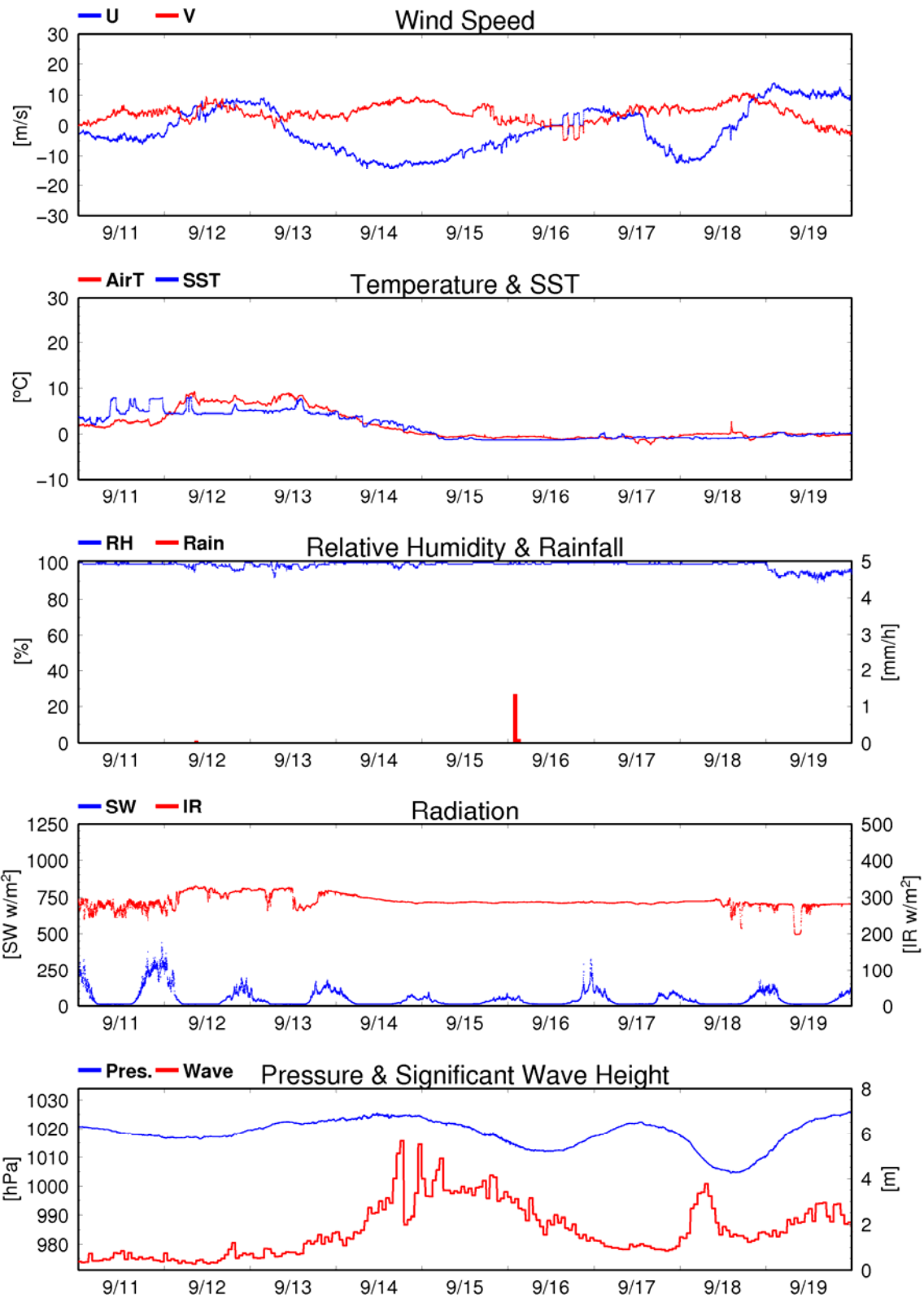

Fig. 2.3.1 (Continued)

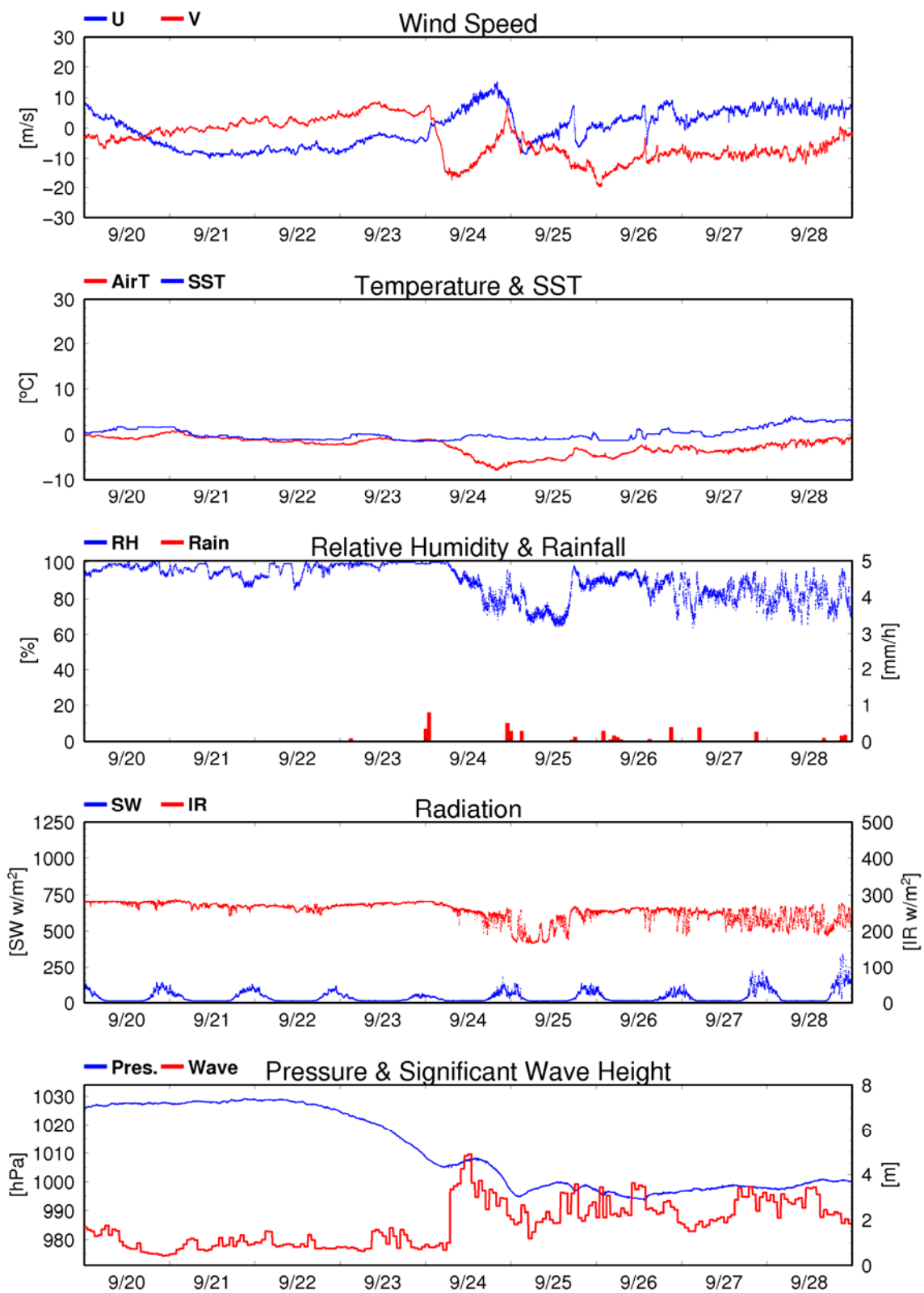

Fig. 2.3.1 (Continued)

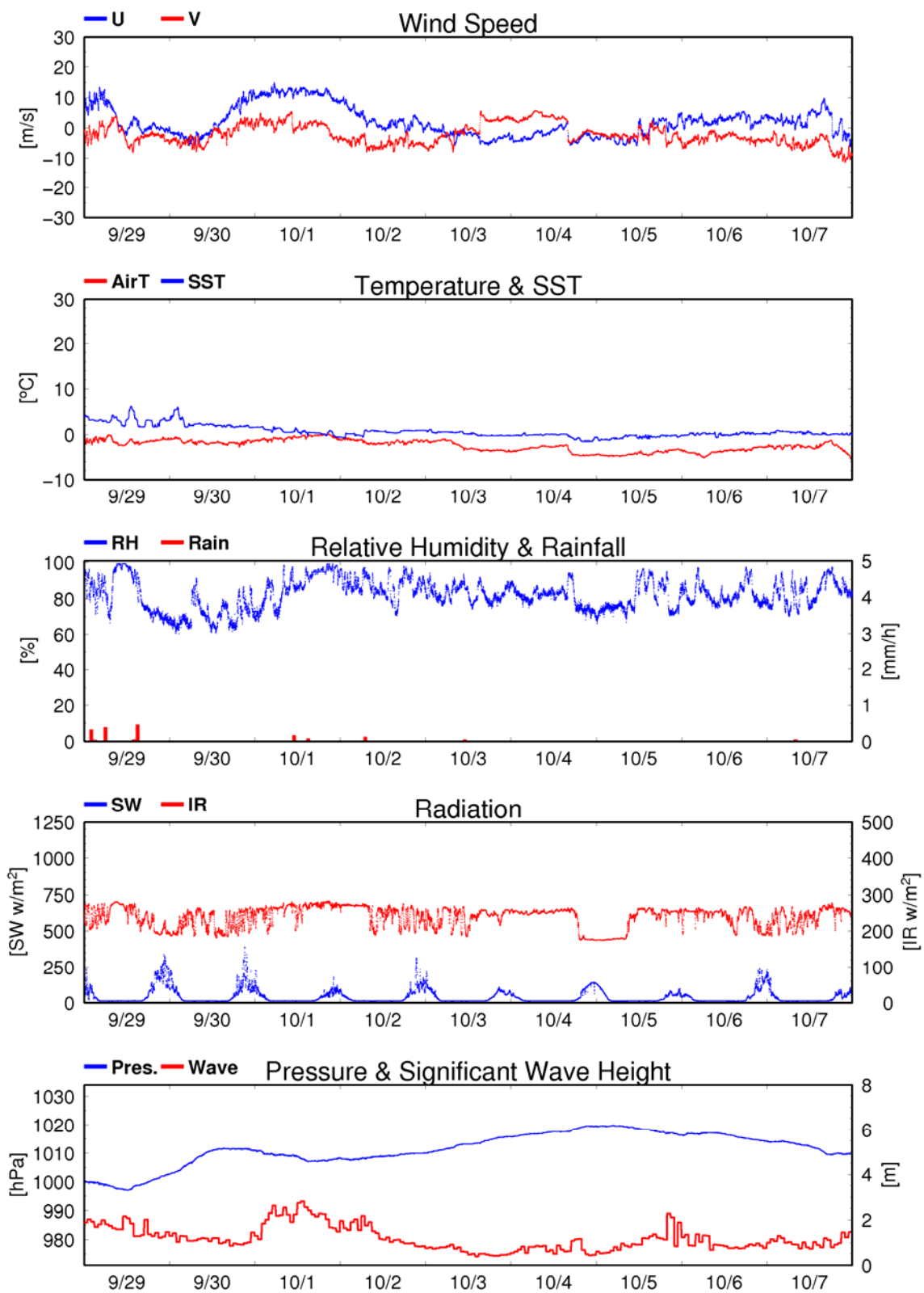

Fig. 2.3.1 (Continued)

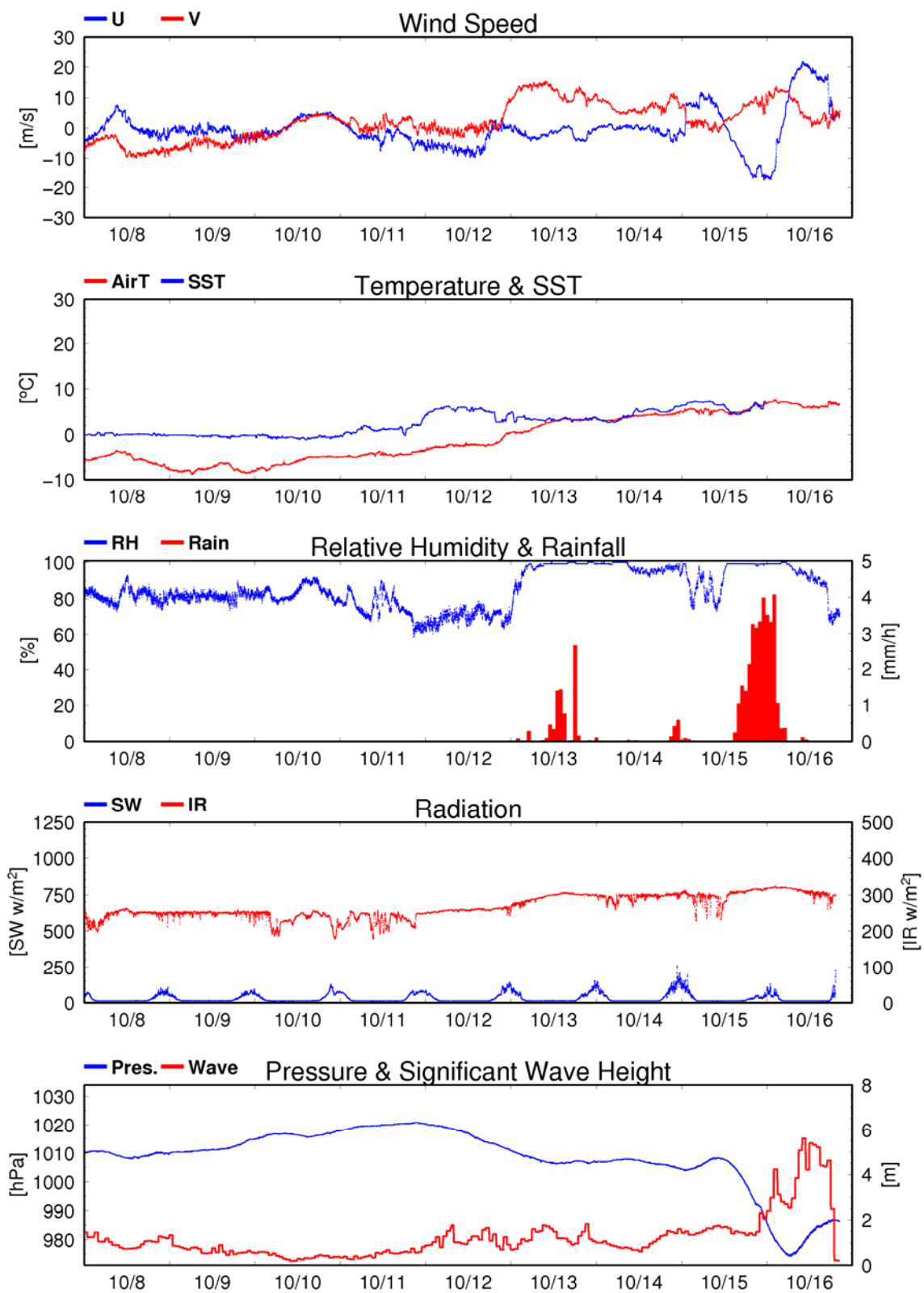

Fig. 2.3.1 (Continued)

2.4. Ceilometer

(1) Personnel

Jun Inoue	JAMSTEC: Principal Investigator	
Kazuho Yoshida	GODI	- Leg1 -
Norio Nagahama	GODI	- Leg2 -
Satoshi Okumura	GODI	- Leg2 -
Souichiro Sueyoshi	GODI	- Leg2 -
Asuka Doi	GODI	- Leg2 -
Wataru Tokunaga	MIRAI Crew	

(2) Objectives

The information of cloud base height and the liquid water amount around cloud base is important to understand the process on formation of the cloud. As one of the methods to measure them, the ceilometer observation was carried out.

(3) Parameters

1. Cloud base height [m].
2. Backscatter profile, sensitivity and range normalized at 30 m resolution [1/srad*m].
3. Estimated cloud amount [oktas] and height [m]; Sky Condition Algorithm.

(4) Methods

We measured cloud base height and backscatter profile using ceilometer (CT-25K, VAISALA, Finland) throughout the MR10-05 cruise.

Major parameters for the measurement configuration are as follows;

Laser source:	Indium Gallium Arsenide (InGaAs) Diode
Transmitting wavelength:	905±5 nm at 25 degC
Transmitting average power:	8.9 mW
Repetition rate:	5.57 kHz
Detector:	Silicon avalanche photodiode (APD)
	Responsibility at 905 nm: 65 A/W
Measurement range:	0 ~ 7.5 km
Resolution:	50 ft in full range
Sampling rate:	60 sec
Sky Condition	0, 1, 3, 5, 7, 8 oktas (9: Vertical Visibility)
	(0: Sky Clear, 1:Few, 3:Scattered, 5-7: Broken, 8: Overcast)

On the archive dataset, cloud base height and backscatter profile are recorded with the resolution of 30 m (100 ft).

(5) Preliminary results

Figure 2.4-1 shows the time series of the cloud base height and backscatter profiles throughout this cruise.

(6) Data archives

The raw data obtained during this cruise will be submitted to the Data Integration and Analysis Group (DIAG) in JAMSTEC.

(7) Remarks

i) Window cleaning;

02:28UTC 28 Aug. 2010

00:16UTC 30 Aug. 2010

17:58UTC 01 Sep. 2010

21:07UTC 12 Sep. 2010

22:10UTC 19 Sep. 2010

ii) The following period, data was not available.

06:54UTC - 07:14UTC 12 Oct. 2010

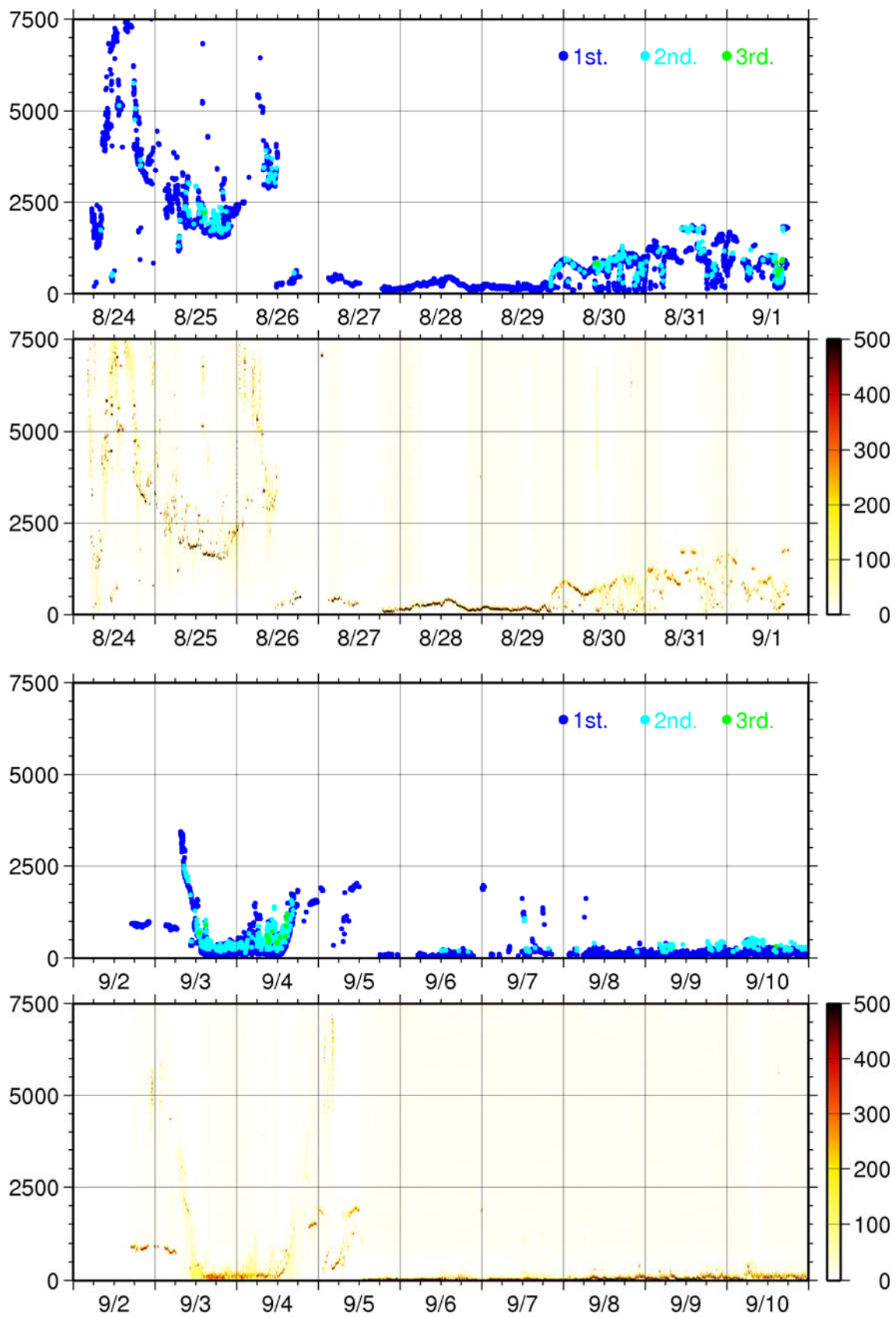

Figure 2.4-1. Clouds base height and Backscatter profiles throughout the MR10-05 cruise

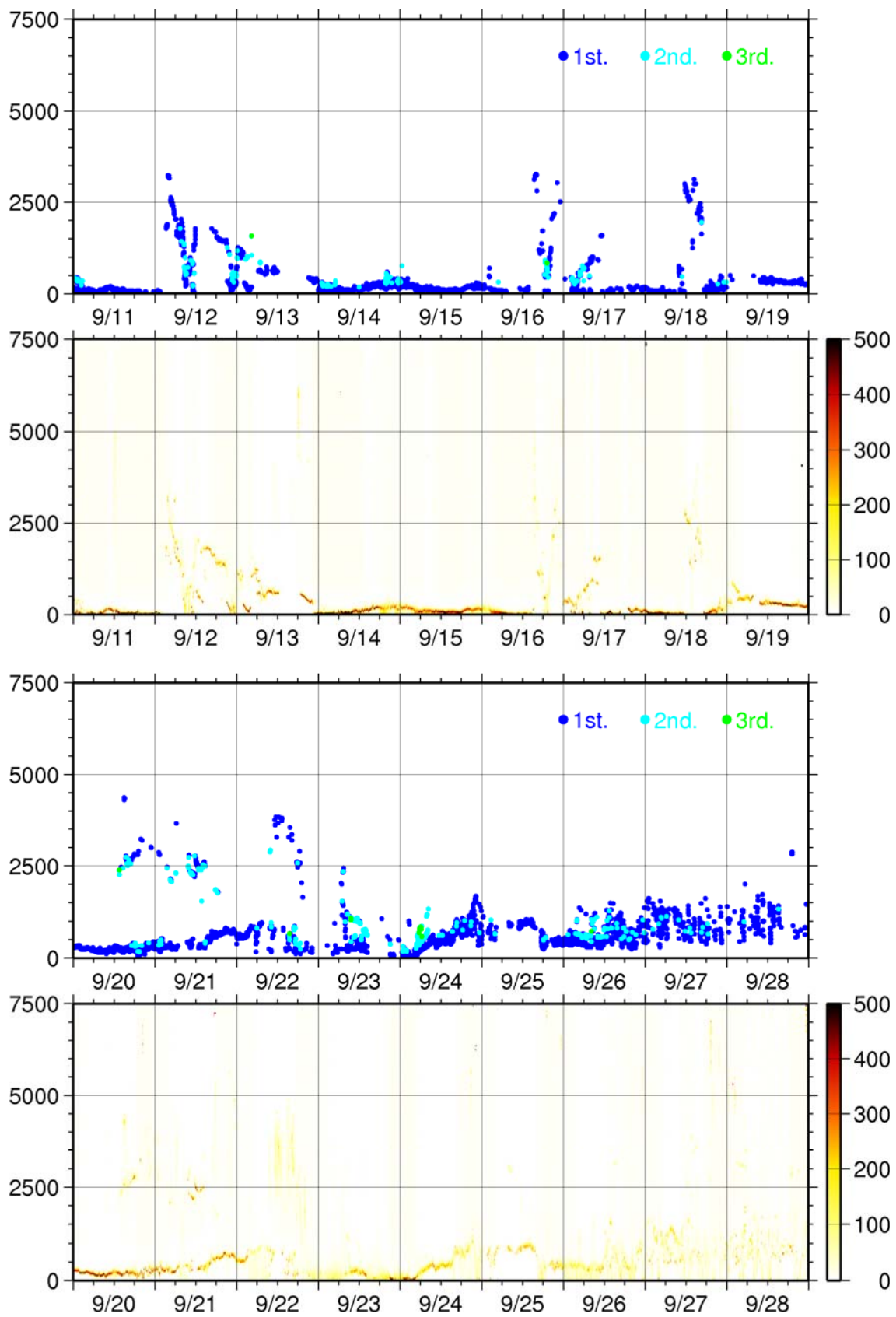

Figure 2.4-1. (Continued)

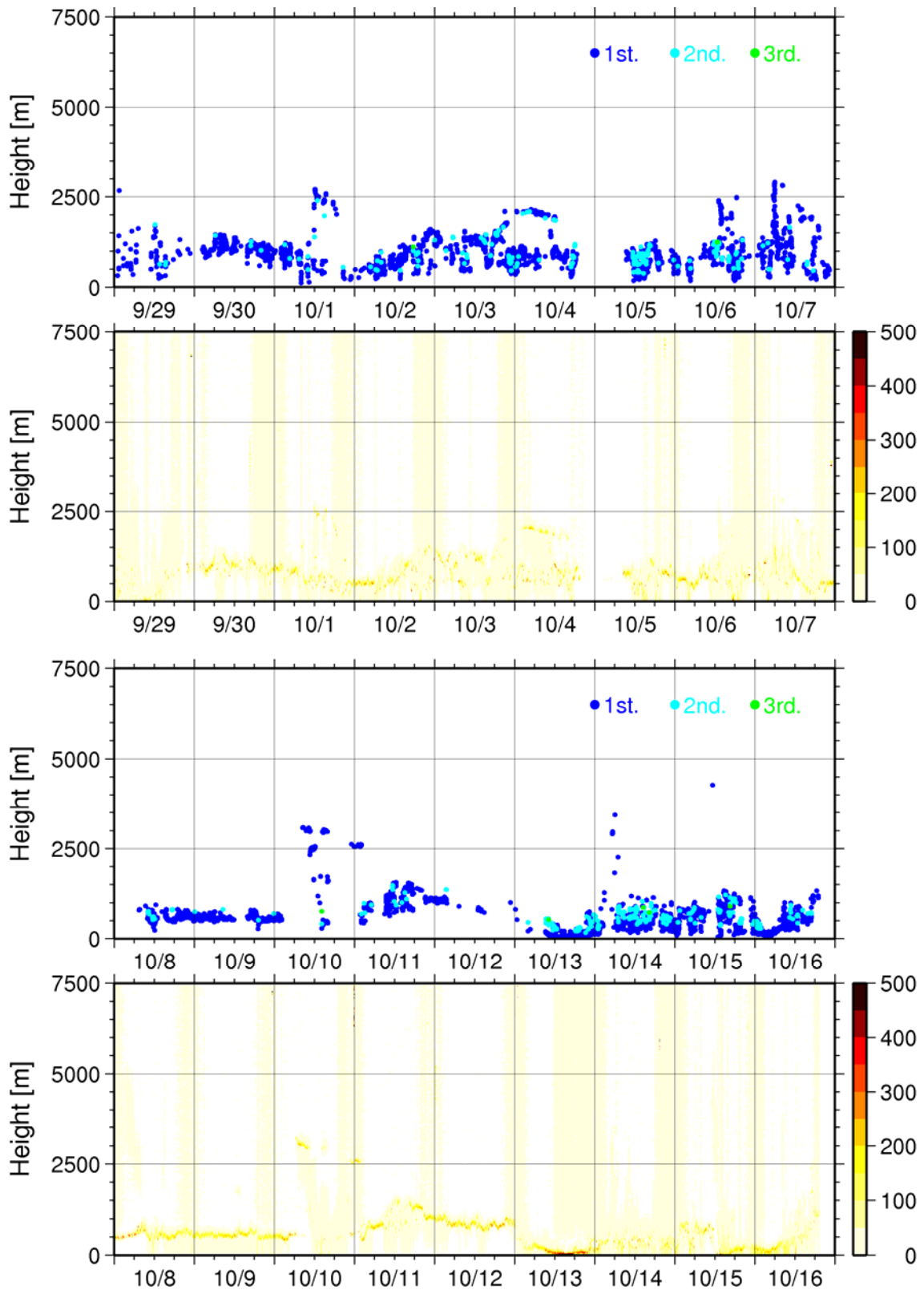

Figure 2.4-1. (Continued)

2.5. Measurements of DMS in seawater and atmosphere over the northern North Pacific during MR10-05 (Leg 1)

(1) Personnel

Ippei Nagao (Nagoya University): Principal investigator

(2) Objective

An accurate estimation of the sea-air DMS flux is required to improve an estimation of the impact of DMS on the aerosol formation in the marine air. Thus far, the bulk method which is a traditional one but includes a large uncertainty has been used, because no devices of trace gases such as DMS have been available for the eddy correlation (EC) method, which is more accurate than the bulk method. Utilizing a chemiluminescence induced by reaction of DMS with fluorine (F_2), the fast measurement system of DMS for the EC method was developed and installed on R/V Mirai during the cruise of MR10-05. In this cruise, these two methods are applied to the DMS flux measurement on board R/V Mirai (MR10-05 Leg 1) over the northern North Pacific. Then the results of two methods will be analyzed to improve the DMS flux calculation.

(3) Parameters

- Atmospheric DMS concentration
- Seawater DMS concentration

(4) Instruments and Methods

i. Measurement system by GC/FPD for the bulk method

Atmospheric DMS concentration

Sample air was introduced through 20 m long Teflon-tube (OD: 10mm, and ID: 8 mm) from the compass deck to the Environmental Research Laboratory of R/V Mirai with the flow rate at 30~36 L/min by sampling pump (Iwaki Co. Ltd.). This sample air was separated in the manifold to be introduced to the DMS analysis system with the flow rate at 100 ml/min. The sample air was then concentrated on the concentration tube packed with Tenax-GR (60/80 mesh, GL Science Co. Ltd.) at $-75\text{ }^{\circ}\text{C}$ by liquid CO_2 after removing water vapor by perma pure dryer (MD-070-48F, GL Science Co. Ltd.). Then the concentration tube was abruptly heated to $+180\text{ }^{\circ}\text{C}$ within 1.5 min and DMS trapped on Tenax-GR was introduced to Gas Chromatography equipped with a flame photometric detector (GC-14B, Shimadzu Co. Ltd.) by the carrier gas (ultra high purified (UHP) nitrogen (N_2) gas). Analysis column of this system was β - β' oxydipropionitrile glass column (ZO-1, Shimadzu Co. Ltd.). Temperature in the column oven was set to be $60\text{ }^{\circ}\text{C}$. Calibration of this system was performed with DMS standard gas (5.16 ppmv, N_2 base, Nagoya-Kosan Co. Ltd.). The detection limit (DL) was estimated to be 30 pptv in 4.5 liter of STP. The precision was $\pm 10\%$.

Seawater DMS concentration

100mL of seawater samples were taken to the brown glass bottles in the sea surface water monitoring laboratory of R/V Mirai. After overflow of seawater, the sample bottle was immediately sealed with butyl gum cap with care to exclude air bubbles. Then the analysis of DMS was performed on board within an hour by a purge and trap. A 30 ml of seawater sample was introduced into a degasification vessel by syringe through GF/F filter. Then sample water was sparged for 10 min by the UHP N₂ gas. The flow rate was about 120 ml/min. The extracted gas was then concentrated on the concentration tube (60/80 mesh Tenax-GR, GL Science Co. Ltd.). Then the determination of DMS was carried out by the same procedures as those for air samples. Reproducibility of this system was about ± 12%, and the detection limit was about 0.1 nM in 25 ml water sample.

ii. Measurement system by fluorine induced chemiluminescence for the EC method

High speed sensor for DMS concentration based on its fast chemiluminescence reaction with molecular fluorine (F₂) was developed following the document by Hills et al [1998] to measure the atmospheric DMS concentration within a 0.1 second for the eddy correlation method. Intense chemiluminescence occurred upon reaction of F₂ with a sulfur-containing compound, as follows:



Emission in the wavelength range 500~750 nm was monitored with a photomultiplier tube (H7421 and R2228P, Hamamatsu Photonics, Co. Ltd.). Under suitable conditions, residence time of the sample air in the reaction cell was very short (much less than 0.1 sec). Assuming that reaction (R1) was a pseudo 1st order reaction, reaction (R1) was expected to almost complete within the residence time of sample air in the cell. Product gases were evacuated from the reaction cell and then scrubbed of F₂ and HF via a chemical trap, which converts excess F₂ to CF₄ on activated carbon. This system was installed on the top of the foremast of R/V Mirai. Sample air was introduced from the top of the foremast through a Teflon-tube (OD: 8mm and c.a. 3m of length), and the sample air after analysis was exhausted outside. Signals of this reaction were recorded in personal computer. For calibration, the output of this reaction with DMS standard gas (0.76 ppmv) was also measured.

Estimation of Flux

The DMS fluxes by the bulk method and the EC method can be calculated as follows:

$$F_{\text{bulk}} = K_w (C_w - C_A / H_{\text{DMS}}) \quad (\text{Eq.1})$$

$$F_{\text{EC}} = \frac{1}{T} \int_0^T w' C_A' dt \quad (\text{Eq.2})$$

where K_w is the exchange coefficient of DMS at the sea surface. C_w and C_A are the DMS

concentrations in the surface seawater and the atmosphere, respectively. H_{DMS} is the Henry constant of DMS. T is the time for integration (generally about 30min). w' and C_A' are the fluctuations of the vertical wind speed and the DMS concentration in the atmosphere from their average values, respectively. For the bulk method, C_W and C_A were measured by the GC/FPD system, and for the EC method, C_A variations within 0.1 sec were measured by the chemiluminescence system. The vertical component of wind speed as well as inclination and acceleration of ship movement measured by the CO_2 flux measurement system by Okayama University will be used for the DMS flux calculation.

(5) Preliminary Results

Figure 2.5-1(a) shows the temporal variations in the atmospheric DMS concentrations measured by this GC/FPD system. Gradual increase in the concentration was observed from August 27 to 30, then the concentration decreased. These variations were not related with those in the surface seawater shown in Figure 2.5-1(b). Detail analyses for elucidation of these results will be done by calculating the sea-air DMS flux, and other parameters affecting the atmospheric DMS concentrations.

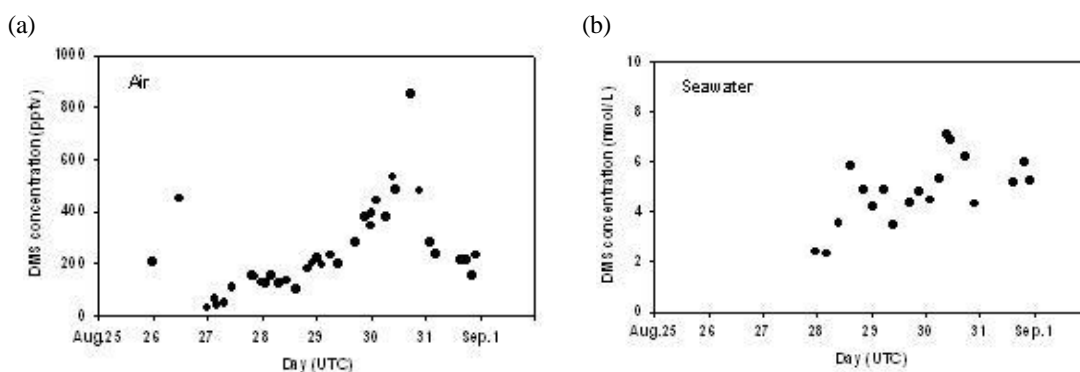

Figure 2.5-1. Temporal variations in the DMS concentrations measured by the GC/FPD system; (a) atmospheric DMS concentration and (b) seawater DMS concentration measured during MR10-05 (Leg 1) cruise.

Figure 2.5-2 shows an example of the signal outputs of photon counting from the fluorine induced chemiluminescence method for fast measurement of atmospheric DMS concentration. Significant increases in the photon counts were observed when ambient marine air was introduced to this system as compared to the photon signals when zero air (UHP N_2 gas) was introduced. This increase in the photon levels can be attributed to the reaction of DMS with F_2 .

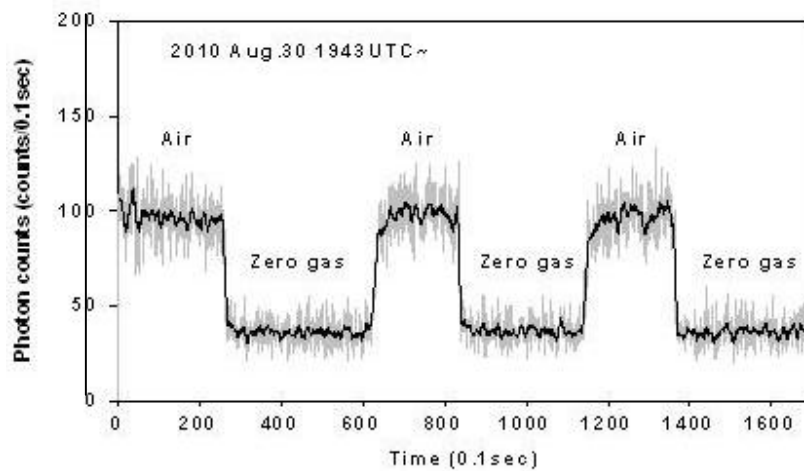

Figure 2.5-2. Photon signal of chemiluminescence of sample air and zero gas with F_2 . Data shown in this graph was obtained from 1943 UTC on Aug. 30.

(6) Data archives

The data of atmospheric and seawater DMS concentrations will be submitted to the Data Management Office (DMO) of JAMSTEC.

2.6. Behavior of Chemicals and Air-Sea Physical Flux in Sea Fog

(1) Personnel

Fumiyoshi KONDO	(The University of Tokyo)	Principal Investigator
Sujaree BUREEKUL	(The University of Tokyo)	(not on board)
Hiroshi FURUTANI	(The University of Tokyo)	(not on board)
Jinyoung JUNG	(The University of Tokyo)	(not on board)
Mitsuo UEMATSU	(The University of Tokyo)	(not on board)

(2) Objective

Aerosols influence climate system both indirectly, by forming cloud condensation nuclei and increasing cloud-top reflectivity, and directly, by backscattering incoming solar radiation. Then, it is important to determine the properties of aerosols in the marine atmosphere. There are two aerosol removal process from the atmosphere; one is dry (gravitational settling) and wet (precipitation) depositions, and the other is the removal process by sea fog. One of the aim in this study is to characterize the typical chemical composition of sea fog, a kind of stratus, and its acidification process over the Arctic Ocean. Moreover, the study of the processes at the interface of ocean and atmosphere is essential to develop profound understanding of the mechanisms driving ocean-atmosphere interaction. Eddy covariance technique is the only direct measurement of air-sea turbulent particle and gas fluxes. This technique has little assumption (constant flux layer and steady state), and may evaluate small spatial and temporal particle and gas fluxes. For these reasons, we hope that the eddy covariance technique investigates uncertain processes that control the air-sea particle (aerosol) and gas (CO₂) fluxes.

(3) Method

Table 2.6-1 shows a list of aerosol and atmospheric observations conducted during the MR10-05 cruise. Detailed laboratory chemical analysis and data analysis will be performed. Results from these atmospheric observations and their temporal/spatial/latitudinal variations will be further compared with the variations in the activity of marine primary production and biogenic precursor gas concentrations in both atmosphere and seawater to evaluate the linkage between atmospheric aerosols and marine primary production.

(4) Data archives

The data obtained in this cruise will be submitted to the Data Management Office (DMO) of JAMSTEC.

Table 2.6-1. Atmospheric Aerosol and Gas Measurement

Category	Instrument	Type	Property	Time Resolution	Note
Atmospheric Aerosol	OPC	Size Distribution	0.1 - 0.5 μm	5 min	5 size bin
	OPC		0.5 - 5 μm	5 min	5 size bin
	Filter Sampling by AS-900	Chemical	Trace Metal	1 day	2 size fraction
		Composition	Ionic Composition	(12 hours from Stn. 5)	($d > 2.5 \mu\text{m}$, $d < 2.5 \mu\text{m}$)
Atmospheric Gas	O ₃ Monitor	Concentration	O ₃ Gas	1 min	
Turbulent Gas and Particle Fluxes	SAT		Wind Velocity		
	Three-axis Accelerometer		Ship Motion		
	Three-axis Rate Gyro			10 Hz	
	CO ₂ /H ₂ O gas analyzer		CO ₂ and H ₂ O Gas		
	Condensation Particle Counter		Fine Particle		5 nm – 3 μm diameters
	Fog Monitor		Coarse Particle		2 μm – 50 μm diameters

2.7. Air-sea surface eddy flux measurement

(1) Personnel

Osamu Tsukamoto	(Okayama University)	Principal Investigator	* not on board
Fumiyoshi Kondo	(University of Tokyo)		
Hiroshi Ishida	(Kobe University)		* not on board
Kazuho Yoshida	(GODI)		
Norio Nagahama	(GODI)		

(2) Objective

To better understand the air-sea interaction, accurate measurements of surface heat and fresh water budgets are necessary as well as momentum exchange through the sea surface. In addition, the evaluation of surface flux of carbon dioxide is also indispensable for the study of global warming. Sea surface turbulent fluxes of momentum, sensible heat, latent heat, and carbon dioxide were measured by using the eddy correlation method that is thought to be most accurate and free from assumptions. These surface heat flux data are combined with radiation fluxes and water temperature profiles to derive the surface energy budget.

(3) Instruments and Methods

The surface turbulent flux measurement system (Fig. 2.7-1) consists of turbulence instruments (Kaijo Co., Ltd.) and ship motion sensors (Kanto Aircraft Instrument Co., Ltd.). The turbulence sensors include a three-dimensional sonic anemometer-thermometer (Kaijo, DA-600) and an infrared hygrometer (LICOR, LI-7500). The sonic anemometer measures three-dimensional wind components relative to the ship. The ship motion sensors include a two-axis inclinometer (Applied Geomechanics, MD-900-T), a three-axis accelerometer (Applied Signal Inc., QA-700-020), and a three-axis rate gyro (Systron Donner, QRS-0050-100). LI7500 is a CO₂/H₂O turbulence sensor that measures turbulent signals of carbon dioxide and water vapor simultaneously. These signals are sampled at 10 Hz by a PC-based data logging system (Labview, National Instruments Co., Ltd.). By obtaining the ship speed and heading information through the Mirai network system it yields the absolute wind components relative to the ground. Combining wind data with the turbulence data, turbulent fluxes and statistics are calculated in a real-time basis. These data are also saved in digital files every 0.1 second for raw data and every 1 minute for statistic data.

(4) Observation log

The observation was carried out throughout this cruise.

(5) Data Policy and citation

All data are archived at Okayama University, and will be open to public after quality checks and corrections. Corrected data will be submitted to Data Management Office (DMO) of JAMSTEC.

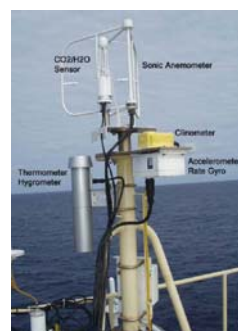

Fig. 2.7-1. Turbulent flux measurement system on the top deck of the foremast.

2.8. Lidar observations of clouds and aerosols

(1) Personnel

Nobuo Sugimoto (National Institute for Environmental Studies):

Principal Investigator/ not on board

Ichiro Matsui (National Institute for Environmental Studies): not on board

Atsushi Shimizu (National Institute for Environmental Studies): not on board

Tomoaki Nishizawa (National Institute for Environmental Studies): not on board

lidar operation was supported by GODI

(2) Objectives

Objectives of the observations in this cruise is to study distribution and optical characteristics of ice/water clouds and marine aerosols using a two-wavelength lidar.

(3) Measured parameters

- Vertical profiles of backscattering coefficient at 532 nm
- Vertical profiles of backscattering coefficient at 1064 nm
- Depolarization ratio at 532 nm

(4) Method

Vertical profiles of aerosols and clouds were measured with a two-wavelength lidar. The lidar employs a Nd:YAG laser as a light source which generates the fundamental output at 1064 nm and the second harmonic at 532 nm. Transmitted laser energy is typically 30 mJ per pulse at both of 1064 and 532 nm. The pulse repetition rate is 10 Hz. The receiver telescope has a diameter of 20 cm. The receiver has three detection channels to receive the lidar signals at 1064 nm and the parallel and perpendicular polarization components at 532 nm. An analog-mode avalanche photo diode (APD) is used as a detector for 1064 nm, and photomultiplier tubes (PMTs) are used for 532 nm. The detected signals are recorded with a transient recorder and stored on a hard disk with a computer. The lidar system was installed in a container which has a glass window on the roof, and the lidar was operated continuously regardless of weather. Every 10 minutes vertical profiles of four channels (532 parallel, 532 perpendicular, 1064, 532 near range) are recorded.

(5) Results

As lidar data has not been brought to NIES, a quick-look of lidar observation on September 12 is shown in Figure 2.8-1. Although data duration is one day, multi-layered structure of the atmosphere is depicted. Cirrus clouds appeared between 8 – 10 km around 03:00 UTC where lower cloud disappears, and in other period cloud base at 1-4 km are clearly recognized. Backscatter from aerosols below 0.5 km were stronger

in later half of the day.

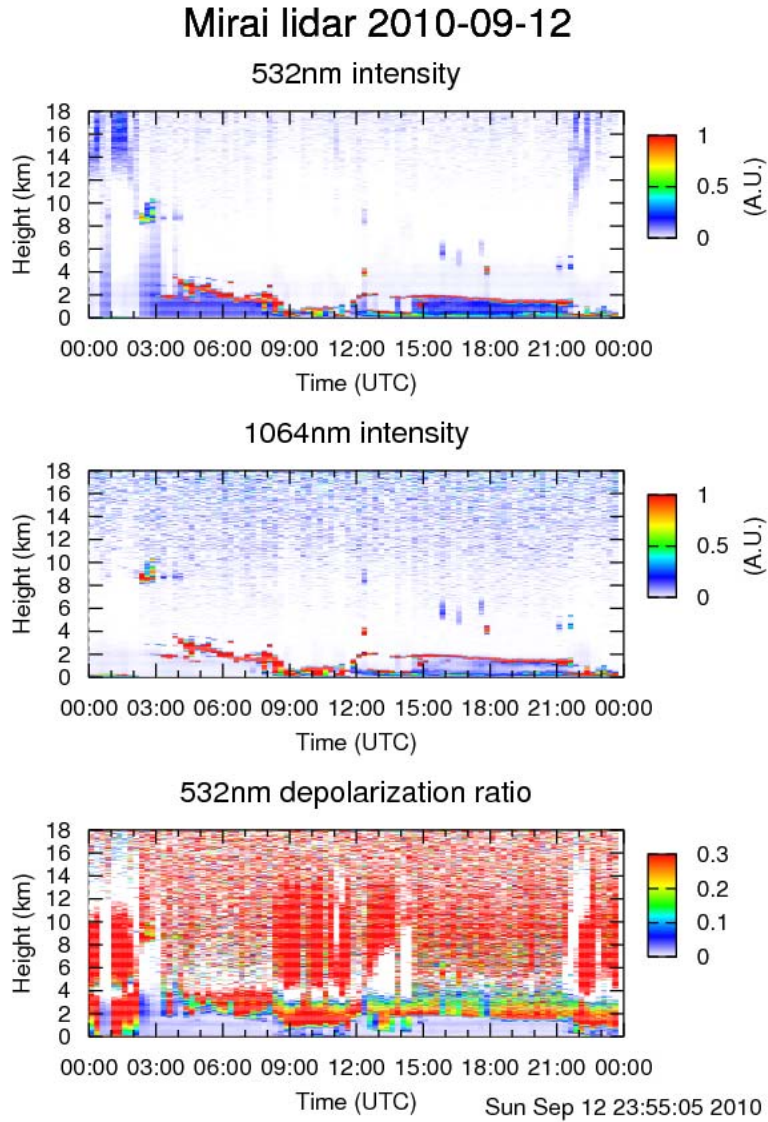

Figure 2.8-1. Time-height sections of (top) backscatter intensity at 532 nm, (middle) backscatter intensity at 1064 nm, and (bottom) depolarization ratio at 532 nm on September 12, 2010.

(6) Data archive

- raw data

lidar signal at 532 nm

lidar signal at 1064 nm

depolarization ratio at 532 nm

temporal resolution 10min/ vertical resolution 6 m

data period (UTC): August 25 – October 16, 2010

- processed data (plan)

cloud base height, apparent cloud top height

phase of clouds (ice/water)

cloud fraction

boundary layer height (aerosol layer upper boundary height)

backscatter coefficient of aerosols

particle depolarization ratio of aerosols

(7) Data policy and Citation

Contact NIES lidar team (nsugimot/i-matsui/shimizua/nisizawa@nies.go.jp)

to utilize lidar data for productive use.

2.9. Sky radiometer (operated by K. Aoki, Univ. of Toyama)

(1) Personnel

Kazuma Aoki (University of Toyama) Principal Investigator / not onboard
Tadahiro Hayasaka (Tohoku University) Co-worker / not onboard

(2) Objective

Objective of the observations in this aerosol is to study distribution and optical characteristics of marine aerosols by using a ship-borne sky radiometer (POM-01 MKII: PREDE Co. Ltd., Japan). Furthermore, collections of the data for calibration and validation to the remote sensing data were performed simultaneously.

(3) Parameters

@ Measured parameters

- Aerosol optical thickness at five wavelengths (400, 500, 675, 870 and 1020 nm)
- Ångström exponent
- Single scattering albedo at five wavelengths
- Size distribution of volume (0.01 μm – 20 μm)

GPS provides the position with longitude and latitude and heading direction of the vessel, and azimuth and elevation angle of sun. Horizon sensor provides rolling and pitching angles.

(4) Instruments and Methods

Sky radiometer is measuring the direct solar irradiance and the solar aureole radiance distribution, has seven interference filters (0.34, 0.4, 0.5, 0.675, 0.87, 0.94, and 1.02 μm). Analysis of these data is performed by SKYRAD.pack version 4.2 developed by Nakajima *et al.* 1996.

(5) Observation log (Preliminary results)

This study is not onboard. Data obtained in this cruise will be analyzed at University of Toyama.

(6) Data archives

Measurements of aerosol optical data are not archived so soon and developed, examined, arranged and finally provided as available data after certain duration. All data will be archived at University of Toyama (K.Aoki, SKYNET/SKY: <http://skyrad.sci.u-toyama.ac.jp/>) after the quality check and submitted to JAMSTEC.

2.10. Tropospheric aerosol and gas profile observations by MAX-DOAS on a research vessel

(1) Personnel

Hisahiro TAKASHIMA (PI, JAMSTEC/RIGC, not on board)
Hitoshi IRIE (JAMSTEC/RIGC)
Yugo KANAYA (JAMSTEC/RIGC)

(2) Objectives

- To quantify typical background values of atmospheric aerosol and gas over the ocean
- To clarify transport processes from source over Asia to the ocean (and also clarify the gas emission from the ocean (including organic gas))
- To validate satellite measurements (as well as chemical transport model)

(3) Methods

Multi-Axis Differential Optical Absorption Spectroscopy (MAX-DOAS) is a passive remote sensing technique using scattered visible and ultraviolet (UV) solar radiation at several elevation angles. The MAX-DOAS system used in this study records spectra of scattered solar radiation every 0.5 second. Measurements were made at several elevation angles of 0, 3, 4, 5, 10, 20, 30, 70, 110, 150, 160, 170, 175, 176 and 177 degrees using a movable mirror, which repeated the same sequence of elevation angles every 30-min. The UV/visible spectra range was changed every min (284-423 nm and 391-528 nm). On the roof top of the anti-rolling system of R/V *Mirai*, the telescope unit was installed on a gimbal mount, which compensates for the pitch and roll of the ship. A sensor measuring pitch and roll of the telescope unit (10Hz) is used together to measure an offset of elevation angle due to incomplete compensation by the gimbal. The line of sight was in directions of the starboard and portside of the ship.

After measurements were made, we first selected spectrum data with an elevation angle offset less than ± 0.2 degrees. For those spectra, DOAS spectral fitting was performed to quantify the slant column density (SCD), defined as the concentration integrated along the light path, for each elevation angle. In this analysis, SCDs of NO₂ (and other gases) and O₄ (O₂-O₂, collision complex of oxygen) were obtained together. Next, O₄ SCDs were converted to the aerosol optical depth (AOD) and the vertical profile of aerosol extinction coefficient (AEC) at a wavelength of 476 nm using an optimal estimation inversion method with a radiative transfer model. Using derived aerosol information, another inversion is performed to retrieve the tropospheric vertical column/profile of NO₂ and other gases.

(4) Preliminary results

These data for the whole cruise period will be analyzed.

(5) Data archives

The data will be submitted to the Marine-Earth Data and Information Department (MEDID) of JAMSTEC after the full analysis of the raw spectrum data is completed, which will be <2 years after the end of the cruise.

2.11. Sampling for rainfall, atmospheric vapor, seawaters

(1) Personnel

Naoyuki Kurita (JAMSTEC) Principal Investigator (not on-board)
Operator
Norio Nagahama, Kazuho Yoshida (GODI) Operator

(2) Objective

It is well known that the variability of stable water isotopes (HDO and H₂¹⁸O) is closely related with the moisture origin and hydrological processes during the transportation from the source region to deposition site. Thus, water isotope tracer is recognized as the powerful tool to study of the hydrological cycles in the atmosphere. However, oceanic region is one of sparse region of the isotope data, it is necessary to fill the data to identify the moisture sources by using the isotope tracer. In this study, to fill this sparse observation area, intense water isotopes observation was conducted along the cruise track of MR10-05.

(3) Method

Following observation was carried out throughout this cruise.

- Atmospheric moisture sampling:

Water vapor was sampled from the height about 20m above the sea level. The air was drawn at rate of 2-5 L/min through a plastic tube attached to top of the compass deck. The flow rate is regulated according to the water vapor content to collect the sample amount 5-20ml. The water vapor was trapped in a glass trap submerged into an ethanol cooled to 100 degree C by radiator, and then they are collected every 12 hour during the cruise. After collection, water in the trap was subsequently thawed and poured into the 6ml glass bottle.

- Rainwater sampling

Rainwater samples gathered in rain/snow collector were collected just after precipitation events have ended. The collected sample was then transferred into glass bottle (6ml) immediately after the measurement of precipitation amount.

- Surface seawater sampling

Seawater sample taken by the pump from 4m depth were collected in glass bottle (6ml) around the noon at the local time.

(4) Results

Sampling of water vapor for isotope analysis is summarized in Table 2.11-1 (97 samples). The detail of rainfall sampling (23 samples) is summarized in Table 2.11-2. Described rainfall amount is calculated from the collected amount of precipitation. Sampling of surface seawater taken by pump from 4m depths is summarized in Table 2.11-3 (51 samples).

(5) Data archive

Isotopes (HDO, H₂¹⁸O) analysis will be done at RIGC/JAMSTEC, and then analyzed isotopes data will be submitted to JAMSTEC Data Integration and Analysis Group (DIAG).

Table 2.11-1. Summary of water vapor sampling for isotope analysis

Sample	Date	Time (UT)	Date	Time (UT)	Lon	Lat	T.M. (m ³)	Sam. (ml)	H2O ppm
V-1	8.24	09:23	8.25	00:35	141-29E	40-34N	1.98	36.0	22626
V-2	8.25	00:45	8.25	12:36	143-13E	40-23N	0.88	19.7	27859
V-3	8.25	12:45	8.26	00:15	147-02E	40-24N	1.03	15.0	18123
V-4	8.26	00:22	8.27	00:06	153-34E	42-30N	2.13	28.0	16359
V-5	8.27	00:01	8.28	00:04	159-34E	46-09N	2.13	18.0	10516
V-6	8.28	00:11	8.29	00:03	165-49E	49-49N	2.12	16.0	9392
V-7	8.29	00:08	8.30	00:06	172-39E	53-19N	2.16	16.0	9218
V-8	8.30	00:12	8.31	00:52	177-59W	53-45N	2.20	15.0	8485
V-9	8.31	00:58	9.1	00:14	171-37W	54-13N	2.18	14.0	7992
V-10	9.1	00:20	9.1	18:14	166-32W	53-54N	1.61	9.4	7266
V-11	9.2	18:20	9.3	12:00	167-29W	58-15N	2.10	13.2	7822
V-12	9.3	12:03	9.4	00:00	167-33W	61-18N	1.43	9.0	7832
V-13	9.4	00:04	9.4	12:00	168-16W	64-18N	1.42	9.4	8238
V-14	9.4	12:02	9.5	00:00	168-49W	66-00N	1.44	9.2	7951
V-15	9.5	00:02	9.5	12:00	168-50W	68-05N	1.44	9.0	7778
V-16	9.5	12:02	9.6	00:28	167-59W	70-00N	1.50	8.9	7384
V-17	9.6	00:31	9.6	12:02	167-59W	71-36N	1.40	N/A	N/A
V-18	9.6	12:04	9.7	00:09	168-00W	73-37N	1.48	7.1	5970
V-19	9.7	10:14	9.7	12:00	169058W	74-44N	1.56	6.2	4946
V-20	9.7	12:02	9.8	00:00	171-00W	74-36N	1.60	6.1	4744
V-21	9.8	00:08	9.8	12:01	162-26W	74-17N	1.79	7.6	5284
V-22	9.8	12:03	9.9	00:00	162-42W	73-32N	1.82	7.8	5333
V-23	9.9	00:03	9.9	12:00	154-46W	72-09N	1.81	7.6	5225
V-24	9.9	12:02	9.10	00:00	151-40W	71-31N	1.81	8.0	5500
V-25	9.10	00:05	9.10	12:00	150-14W	71-58N	1.79	7.2	5006
V-26	9.10	12:02	9.11	00:03	151-40W	71:30N	1.87	7.4	4925
V-27	9.11	00:09	9.11	12:00	155-21W	71-49N	1.84	7.4	5005
V-28	9.11	12:02	9.12	00:09	155-19W	71-48N	1.89	7.8	5136
V-29	9.12	00:12	9.12	12:00	155-21W	71-48N	1.85	10.0	6727
V-30	9.12	12:02	9.13	00:00	154-54W	71-46N	1.87	10.2	6788

V-31	9.13	00:03	9.13	12:00	160-29W	71-04N	1.87	10.2	6788
V-32	9.13	12:02	9.14	00:00	162-03W	72-36N	1.87	9.8	6522
V-33	9.14	00:04	9.14	12:00	162-02W	74-37N	1.86	8.0	5352
V-34	9.14	12:02	9.15	00:09	165-11W	76-51N	1.89	8.2	5399
V-35	9.15	00:12	9.15	12:00	168-24W	77-52N	1.84	6.0	4058
V-36	9.15	12:02	9.16	00:00	170-00W	78-14N	1.87	6.0	3993
V-37	9.16	00:02	9.16	12:00	169-59W	78-15N	1.86	6.0	4014
V-38	9.16	12:02	9.17	00:00	167-29W	77-38N	1.97	6.2	3917
V-39	9.17	00:02	9.17	12:00	173-08W	76-00N	1.94	6.2	3977
V-40	9.17	12:02	9.18	00:00	175-01W	76-00N	1.95	6.2	3957
V-41	9.18	00:02	9.18	12:00	179-36E	76-27N	1.94	6.6	4234
V-42	9.18	12:02	9.19	00:00	178-10E	75-22N	1.95	6.8	4340
V-43	9.19	00:02	9.19	12:00	178-33W	75-00N	2.15	6.8	3936
V-44	9.19	12:02	9.20	00:00	173-57W	75-09N	2.16	6.5	3745
V-45	9.20	00:10	9.20	12:00	171-03W	74-40N	2.26	6.6	3634
V-46	9.20	12:02	9.21	00:08	170-58W	74-36N	2.33	7.3	3899
V-47	9.21	00:13	9.21	12:00	174-00W	75-24N	2.26	7.0	3854
V-48	9.21	12:02	9.22	00:01	174-00W	76-15N	2.32	6.2	3326
V-49	9.22	00:06	9.22	12:00	170-57W	76-35N	2.31	6.4	3448
V-50	9.22	12:02	9.23	00:00	168-56W	77-09N	2.88	7.9	3414
V-51	9.23	00:02	9.23	12:00	165-06W	77-57N	2.85	8.2	3581
V-52	9.23	12:02	9.24	00:00	164-57W	79-07N	2.88	9.2	3975
V-53	9.24	00:03	9.24	12:00	164-58W	77-51N	2.85	8.0	3493
V-54	9.24	12:02	9.25	00:00	162-00W	77-45N	2.86	4.5	1958
V-55	9.25	00:02	9.25	12:00	160-05W	76-58N	2.85	4.0	1747
V-56	9.25	12:02	9.26	00:00	155-25W	76-30N	3.26	6.2	2367
V-57	9.26	00:02	9.26	12:00	154-44W	75-48N	3.57	8.0	2789
V-58	9.26	12:02	9.27	00:00	156-18W	75-40N	3.60	8.0	2765
V-59	9.27	00:03	9.27	12:00	160-28W	75-20N	3.58	7.2	2503
V-60	9.27	12:02	9.28	00:00	161-58W	73-24N	3.61	7.9	2723
V-61	9.28	00:02	9.28	12:00	161-59W	71-25N	3.55	8.2	2874
V-62	9.28	12:02	9.29	00:00	157-11W	71-15N	3.59	8.4	2912
V-63	9.29	00:02	9.29	12:00	155-13W	71-45N	3.60	9.8	3388
V-64	9.29	12:02	9.30	00:00	154-59W	71-41N	3.61	8.2	2827
V-65	9.30	00:03	9.30	12:00	159-06W	72-25N	3.58	7.6	2642
V-66	9.30	12:02	10.1	00:00	158-30W	73-00N	3.60	7.2	2489
V-67	10.1	00:02	10.1	12:00	156-35W	73-36N	3.58	8.5	2955
V-68	10.1	12:02	10.2	00:00	157-00W	74-24N	3.58	11.8	4102

V-69	10.2	00:02	10.2	12:00	161-33W	74-37N	3.57	9.4	3277
V-70	10.2	12:02	10.3	00:02	165-21W	74-23N	3.58	9.4	3268
V-71	10.3	00:05	10.3	12:00	164-15W	74-35N	3.57	8.0	2789
V-72	10.3	12:02	10.4	00:00	161-59W	75-00N	3.60	7.5	2593
V-73	10.4	00:04	10.4	12:00	165-30W	75-45N	3.57	7.8	2719
V-74	10.4	12:03	10.5	00:00	167-26W	76-34N	3.58	7.0	2433
V-75	10.5	00:02	10.5	12:00	162-57W	75-44N	3.60	6.0	2074
V-76	10.5	12:02	10.6	00:00	166-00W	75-00N	3.60	7.4	2558
V-77	10.6	00:03	10.6	12:00	167-54W	74-38N	3.57	7.6	2649
V-78	10.6	12:02	10.7	00:00	162-46W	73-43N	3.58	7.8	2711
V-79	10.7	00:02	10.7	12:00	160-59W	73-29N	3.57	7.8	2719
V-80	10.7	12:02	10.8	00:00	156-47W	73-43N	3.58	8.3	2885
V-81	10.8	00:02	10.8	11:58	158-27W	73-44N	3.58	6.4	2225
V-82	10.8	12:00	10.9	00:00	157-31W	74-01N	3.62	6.0	2063
V-83	10.9	00:02	10.9	12:00	158-53W	73-48N	3.60	5.0	1728
V-84	10.9	12:03	10.10	00:00	160-29W	74-12N	3.60	5.7	1970
V-85	10.10	00:02	10.10	12:00	162-48W	74-48N	3.67	5.8	1967
V-86	10.10	12:02	10.11	00:00	162-00W	73-23N	3.68	7.0	2367
V-87	10.11	00:02	10.11	12:00	162-00W	71-24N	3.67	6.0	2035
V-88	10.11	12:02	10.12	00:00	166-00W	70-18N	3.68	6.0	2029
V-89	10.12	00:02	10.12	12:00	168-50W	69-30N	3.67	6.0	2035
V-90	10.12	12:03	10.13	00:00	168-49W	67-28W	3.67	7.7	2611
V-91	10.13	00:02	10.13	12:02	168-48W	66-17N	3.68	14.0	4734
V-92	10.13	12:05	10.13	23:56	168-22W	65-40N	2.85	13.8	6026
V-93	10.13	23:57	10.14	12:00	167-42W	63-27N	2.89	13.6	5856
V-94	10.14	12:02	10.15	00:00	167-32W	61-20N	2.51	11.8	5850
V-95	10.15	00:02	10.15	12:00	167-32W	58-24N	2.29	9.8	5326
V-96	10.15	12:04	10.16	00:00	166-44W	56-20N	2.28	12.0	6550
V-97	10.16	00:02	10.16	18:10	166-29W	53-54N	2.16	11.4	6568

Table 2.11-2. Summary of precipitation sampling for isotope analysis.

	Date	Time (UT)	Lon	Lat	Date	Time (UT)	Lon	Lat	Rain (mm)
R-1	8.24	09:00	141-27E	41-32N	8.31	04:25	176-37W	53-49N	N/A
R-2	8.31	04:25	176-37W	53-49N	9.01	18:11	166-32W	53-54N	N/A
R-3	9.02	18:00	N/A	N/A	9.04	07:52	167-35W	63-16N	5.5
R-4	9.04	07:52	167-35W	63-16N	9.05	02:37	168-50W	66-26N	1.4
R-5	9.05	02:37	168-50W	66-26N	9.13	23:46	162-03W	72-32N	0.5

R-6	9.13	23:46	162-03W	72-32N	9.18	16:59	178-54E	76-00N	3.5
R-7	9.22	06:11	172-59W	76-39N	9.22	18:35	170-00W	77-05N	0.0
R-8	9.22	18:35	170-00W	77-05N	9.23	08:55	166-12W	77-23N	6.3
R-9	9.23	08:55	166-12W	77-23N	9.23	22:00	164-59W	79-11N	0.6
R-10	9.23	22:00	164-59W	79-11N	9.24	00:02	164-56W	79-07N	1.8
R-11	9.24	00:02	164-56W	79-07N	9.24	05:50	165-01W	78-52N	0.5
R-12	9.24	05:50	165-01W	78-52N	9.25	03:02	161-16W	77-45N	3.6
R-13	9.25	03:02	161-16W	77-45N	9.26	23:37	156-17W	75-39N	3.3
R-14	9.26	23:37	156-17W	75-39N	9.27	20:52	162-01W	74-00N	2.9
R-15	9.27	20:52	162-01W	74-00N	9.29	05:07	157-40W	71-29N	5.6
R-16	9.29	05:10	157-40W	71-29N	9.29	17:20	155-20W	71-47N	6.7
R-17	9.29	17:20	155-20W	71-47N	10.01	10:20	156-59W	73-28N	0.6
R-18	10.01	10:20	156-59W	73-28N	10.02	09:21	159-44W	74-45N	0.5
R-19	10.02	09:21	159-44W	74-45N	10.05	17:03	163-27W	75-10N	2.2
R-20	10.05	17:03	163-27W	75-10N	10.06	23:57	162-45W	73-42N	2.50
R-21	10.06	23:58	162-45W	73-42N	10.07	07:24	162-41W	73-13N	1.0
R-22	10.07	07:24	162-41W	73-13N	10.10	03:02	163-02W	74-23N	3.7
R-23	10.10	03:02	163-04W	74-23N	10.16	18:08	166-29W	53-55N	19.7

Table 2.11-3. Summary of water vapor sampling for isotope analysis

Sampling No.	Date	Time (UTC)	Position		
			LON	LAT	
MR10-05 O-	1	8.26	02:30	147-48E	40-25N
MR10-05 O-	2	8.27	01:00	153-54E	42-38N
MR10-05 O-	3	8.28	00:00	159-33E	46-08N
MR10-05 O-	4	8.28	23:01	165-32E	49-39N
MR10-05 O-	5	8.29	22:00	171-59E	53-03N
MR10-05 O-	6	8.31	00:45	178-02W	53-45N
MR10-05 O-	7	8.31	20:08	172-09W	54-08N
MR10-05 O-	8	9.2	20:38	166-35W	54-27N
MR10-05 O-	9	9.3	20:01	167-58W	60-15N
MR10-05 O-	10	9.4	20:00	168-24W	65-44N
MR10-05 O-	11	9.5	20:03	168-50W	69-30N
MR10-05 O-	12	9.6	20:00	168-00W	73-00N
MR10-05 O-	13	9.7	20:00	170-54W	74-36N
MR10-05 O-	14	9.8	20:00	163-44W	73-48N
MR10-05 O-	15	9.9	20:01	152-50W	71-44N
MR10-05 O-	16	9.10	20:00	151-14W	71-39N

MR10-05 O-	17	9.11	22:17	155-00W	71-46N
MR10-05 O-	18	9.12	20:01	155-01W	71-42N
MR10-05 O-	19	9.13	20:00	161-59W	72-00N
MR10-05 O-	20	9.14	21:11	163-52W	76-15N
MR10-05 O-	21	9.15	20:00	169-41W	78-36N
MR10-05 O-	22	9.16	20:00	168-24W	77-51N
MR10-05 O-	23	9.17	20:00	175-16W	76-00N
MR10-05 O-	24	9.18	20:00	178-27E	75-36N
MR10-05 O-	25	9.19	20:02	174-34W	75-11N
MR10-05 O-	26	9.20	20:24	171-00W	74-36N
MR10-05 O-	27	9.21	20:00	171-00W	76-05N
MR10-05 O-	28	9.22	20:00	169-30W	77-07N
MR10-05 O-	29	9.23	20:03	165-00W	79-07N
MR10-05 O-	30	9.24	20:02	163-47W	77-46N
MR10-05 O-	31	9.25	20:04	157-03W	76-37N
MR10-05 O-	32	9.26	20:03	156-07W	75-38N
MR10-05 O-	33	9.27	20:00	162-01W	74-04N
MR10-05 O-	34	9.28	20:03	159-19W	71-06N
MR10-05 O-	35	9.29	20:03	155-39W	71-56N
MR10-05 O-	36	9.30	19:57	158-48W	72-53N
MR10-05 O-	37	10.1	20:05	155-26W	74-05N
MR10-05 O-	38	10.2	20:00	165-15W	74-23N
MR10-05 O-	39	10.3	20:00	162-01W	75-00N
MR10-05 O-	40	10.4	20:00	1667-57W	76-36N
MR10-05 O-	41	10.5	20:00	164-15W	75-00N
MR10-05 O-	42	10.6	20:00	162-56W	73-44N
MR10-05 O-	43	10.7	20:00	159-02W	73-48N
MR10-05 O-	44	10.8	21:55	160-02W	74-04N
MR10-05 O-	45	10.9	20:41	159-55W	74-01N
MR10-05 O-	46	10.10	20:00	162-00W	74-01N
MR10-05 O-	47	10.11	20:00	164-28W	70-33N
MR10-05 O-	48	10.12	20:00	168-50W	68-00N
MR10-05 O-	49	10.13	20:00	168-29W	65-45N
MR10-05 O-	50	10.14	20:01	167-22W	62-15N
MR10-05 O-	51	10.15	20:00	167-08W	56-46N

3. Physical Oceanographic Observation

3.1. CTD/LADCP and water sampling

(1) Personnel

Motoyo Itoh	(JAMSTEC): Principal investigator
Shigeto Nishino	(JAMSTEC)
Yusuke Kawaguchi	(JAMSTEC)
Shinsuke Toyoda	(MWJ): Operation leader
Satoshi Ozawa	(MWJ)
Hirokatsu Uno	(MWJ)
Tomohide Noguchi	(MWJ)
Tatsuya Tanaka	(MWJ)

(2) Objective

Investigation of oceanic structure and water sampling.

(3) Parameters

Temperature (Primary and Secondary)
Conductivity (Primary and Secondary)
Pressure
Dissolved Oxygen (Primary and Secondary)
Fluorescence
Photosynthetically Active Radiation

(4) Instruments and Methods

CTD/Carousel Water Sampling System, which is a 36-position Carousel water sampler (CWS) with Sea-Bird Electronics, Inc. CTD (SBE9plus), was used during this cruise. 12-liter Niskin Bottles, which were washed by alkaline detergent and 1 N HCl, were used for sampling seawater. The sensors attached to the CTD were temperature (Primary and Secondary), conductivity (Primary and Secondary), pressure, dissolved oxygen (Primary and Secondary), deep ocean standards thermometer, altimeter, fluorescence, and PAR sensor. Salinity was calculated by measured values of pressure, conductivity and temperature. The CTD/CWS was deployed from starboard on working deck.

The CTD raw data were acquired on real time using the Seasave-Win32 (ver.7.20g) provided by Sea-Bird Electronics, Inc. and stored on the hard disk of the personal computer. Seawater was sampled during the up cast by sending fire commands from the personal computer.

179 casts of CTD measurements were conducted (Table 3-1-1). Stn.000 was in Leg1. Other casts were in Leg2.

Data processing procedures and used utilities of SBE Data Processing-Win32 (ver.7.18d) and SEASOFT were as follows:

DATCNV: Convert the binary raw data to engineering unit data. DATCNV also extracts bottle information where scans were marked with the bottle confirm bit during acquisition. The duration was set to 4.4 seconds, and the offset was set to 0.0 seconds.

BOTTLESUM: Create a summary of the bottle data. The data were averaged over 4.4 seconds.

ALIGNCTD: Convert the time-sequence of sensor outputs into the pressure sequence to ensure that all calculations were made using measurements from the same parcel of water. Dissolved oxygen data are systematically delayed with respect to depth mainly because of the long time constant of the dissolved oxygen sensor and of an additional delay from the transit time of water in the pumped plumbing line. This delay was compensated by 6 seconds advancing dissolved oxygen sensor output (dissolved oxygen voltage) relative to the temperature data.

WILDEDIT: Mark extreme outliers in the data files. The first pass of WILDEDIT obtained an accurate estimate of the true standard deviation of the data. The data were read in blocks of 1000 scans. Data greater than 10 standard deviations were flagged. The second pass computed a standard deviation over the same 1000 scans excluding the flagged values. Values greater than 20 standard deviations were marked bad. This process was applied to pressure, depth, temperature, conductivity, dissolved oxygen voltage, altimeter and decent rate.

CELLTM: Remove conductivity cell thermal mass effects from the measured conductivity. Typical values used were thermal anomaly amplitude $\alpha = 0.03$ and the time constant $1/\beta = 7.0$.

FILTER: Perform a low pass filter on pressure with a time constant of 0.15 second. In order to produce zero phase lag (no time shift) the filter runs forward first then backward

WFILTER: Perform a median filter to remove spikes in the fluorescence data. A median value was determined by 49 scans of the window.

SECTIONU (original module of SECTION): Select a time span of data based on scan number in order to reduce a file size. The minimum number was set to be the starting time when the CTD package was beneath the sea-surface after activation of the pump. The maximum number of was set to be the end time when the package came up from the surface.

LOOPEDIT: Mark scans where the CTD was moving less than the minimum velocity of

0.0 m/s (traveling backwards due to ship roll).

DESPIKE (original module): Remove spikes of the data. A median and mean absolute deviation was calculated in 1-dbar pressure bins for both down and up cast, excluding the flagged values. Values greater than 4 mean absolute deviations from the median were marked bad for each bin. This process was performed 2 times for temperature, conductivity and dissolved oxygen voltage.

DERIVE: Compute dissolved oxygen.

BINAVG: Average the data into 1-dbar pressure bins.

DERIVE: Compute salinity, potential temperature, and sigma-theta.

SPLIT: Separate the data from an input cnv file into down cast and up cast files.

* Salinity is PSS-78 (Practical Salinity). Dissolved oxygen, potential temperature and density are computed by the salinity.

Configuration file: MR1005A.con

Specifications of the sensors are listed below.

CTD: SBE911plus CTD system

Under water unit:

SBE9plus (S/N 09P79492-0575, Sea-Bird Electronics, Inc.)

Pressure sensor: Digiquartz pressure sensor (S/N 79492)

Calibrated Date: 08 Jul. 2010

Temperature sensors:

Primary: SBE03-04/F (S/N 031524, Sea-Bird Electronics, Inc.)

Calibrated Date: 11 Dec. 2009

Secondary: SBE03-04/F (S/N 031525, Sea-Bird Electronics, Inc.)

Calibrated Date: 29 Jun. 2010

Conductivity sensors:

Primary: SBE04-04/O (S/N 042854, Sea-Bird Electronics, Inc.)

Calibrated Date: 09 Jun. 2010

Secondary: SBE04-04/O (S/N 041172, Sea-Bird Electronics, Inc.)

Calibrated Date: 09 Jun. 2010

Dissolved Oxygen sensors:

Primary: SBE43 (S/N 430394, Sea-Bird Electronics, Inc.)

Calibrated Date: 04 Jun. 2010

Secondary: SBE43 (S/N 430391, Sea-Bird Electronics, Inc.)

Calibrated Date: 19 May 2009

Deep Ocean Standards Thermometer:

SBE35 (S/N 0053, Sea-Bird Electronics, Inc.)

Calibrated Date: 08 Sep. 2010

Altimeter: Benthos PSA-916T (S/N 1100, Teledyne Benthos, Inc.)

Fluorescence: Chlorophyll Fluorometer (S/N 3054, Seapoint Sensors, Inc.)

Photosynthetically Active Radiation: PAR sensor (S/N 0049, Satlantic Inc.)

Carousel water sampler:

SBE32 (S/N 3227443-0391, Sea-Bird Electronics, Inc.)

Deck unit: SBE11plus (S/N 11P7030-0272, Sea-Bird Electronics, Inc.)

(5) Observation log

Table 3-1-1 shows CTD cast table of this cruise. At the last column (Remarks), the kinds of CTD cast are indicated as follows.

CTD: CTD cast only

CTD/R: routine sampling

CTD/RM: sampling for RM

CTD/2L: 2layers sampling

CTD/CN: routine sampling

and sampling for carbon and nitrogen uptake rate (CN)

In some casts, an altimeter did not have a response. So we used a bottom contact sensor.

(6) Preliminary Results

Fig 3-1-1 shows the time drift and the difference between CTD temperature and SBE35, Fig 3-1-2 shows the time drift and the difference between CTD salinity and BTL salinity, Fig 3-1-3 shows the time drift and the difference between CTD oxygen and BTL oxygen, respectively.

In the down cast at 11 - 21dbars of Stn.005, noise was observed in secondary temperature, secondary conductivity and secondary dissolved oxygen raw data.

In the down cast at 59dbar of Stn.080, spike was observed in primary temperature, primary conductivity, primary dissolved oxygen, secondary temperature, secondary conductivity and secondary dissolved oxygen raw data.

In the down cast at 57dbar of Stn.100, spike was observed in primary temperature, primary conductivity, primary dissolved oxygen and secondary dissolved oxygen raw data.

In the down cast at 94dbar of Stn.143, spike was observed in secondary conductivity raw data.

In the down cast at 106 -117dbars of Stn.150, noise was observed in primary temperature and primary conductivity raw data.

In the bottle data at 75 dbar of Stn.163, noise was observed in primary conductivity and dissolved oxygen voltage raw data.

(7) Data archive

All raw and processed data files were copied onto HD provided by Data Management Office (DMO); JAMSTEC will be opened to public via “R/V MIRAI Data Web Page” in the JAMSTEC home page.

Table 3.1-1. MR10-05 CTD Cast table

Stnnbr	Castno	Date(UTC)	Time(UTC)		Bottom Position		Depth	Wire Out	HT Above Bottom	Max Depth	Max Pressure	CTD Filename	Remark
		(mmddy)	Start	End	Latitude	Longitude							
000	1	082610	21:05	21:48	42-09.88N	153-11.19E	5348.0	1002.9	-	1002.0	1012.0	000M01	CTD/RM
001	1	090410	18:06	18:24	65-45.36N	168-29.83W	56.0	43.5	-	45.5	46.0	001M01	CTD/R
002	1	090410	20:43	20:57	65-42.86N	168-15.23W	45.0	37.6	-	40.5	41.0	002M01	CTD/R
003	1	090410	22:37	22:49	65-49.13N	168-49.93W	49.0	40.7	-	43.0	44.0	003M01	CTD/R
004	1	090510	00:25	00:38	66-00.29N	168-49.81W	53.0	42.4	10.0	44.2	44.8	004M01	CTD/R
005	1	090510	03:07	03:11	66-29.83N	168-50.17W	52.0	43.9	-	45.8	46.8	005M01	CTD
006	1	090510	05:33	05:45	67-00.13N	168-50.22W	47.0	38.4	-	40.3	40.8	006M01	CTD/R
007	1	090510	09:08	09:20	67-39.98N	168-55.37W	50.0	37.3	10.0	40.4	40.7	007M01	CTD/R
008	1	090510	11:04	11:19	68-00.05N	168-50.11W	58.0	48.1	-	50.7	51.3	008M01	CTD/R
009	1	090510	14:00	14:03	68-29.93N	168-50.06W	53.0	40.7	10.0	43.2	43.8	009M01	CTD
010	1	090510	16:34	16:47	69-00.04N	168-50.32W	52.0	40.4	10.0	42.4	42.6	010M01	CTD/R
011	1	090510	19:43	19:55	69-30.03N	168-49.91W	52.0	39.3	10.0	42.0	42.1	011M01	CTD/2L
012	1	090510	23:14	23:29	70-00.02N	167-59.88W	48.0	34.7	10.0	37.7	38.3	012M01	CTD/R
013	1	090610	08:06	08:17	71-00.02N	168-00.12W	54.0	39.6	10.0	43.1	43.3	013M01	CTD/R
014	1	090610	14:05	14:18	72-00.04N	167-59.79W	50.0	37.4	10.0	39.6	40.1	014M01	CTD/R
015	1	090610	19:49	20:03	72-59.99N	168-00.06W	64.0	51.4	10.0	53.4	54.1	015M01	CTD/R
016	1	090710	01:59	02:25	74-00.08N	168-00.25W	204.0	184.3	10.0	185.5	187.1	016M01	CTD/R
017	1	090710	08:39	09:03	74-59.89N	168-00.42W	170.0	153.9	9.0	156.1	158.0	017M01	CTD/R
018	1	090710	17:22	17:40	74-36.11N	170-56.22W	227.0	211.3	9.6	212.8	215.0	018M01	CTD/2L
018	2	090710	19:57	20:37	74-35.96N	170-54.21W	224.0	208.0	10.0	209.6	212.0	018M02	CTD/R
019	1	090810	13:20	14:34	74-15.28N	162-35.41W	1084.0	1072.2	7.3	1068.5	1082.6	019M01	CTD/R
020	1	090810	17:44	18:21	74-00.13N	163-13.50W	300.0	286.2	8.7	287.4	290.9	020M01	CTD/R
021	1	090810	20:53	21:19	73-40.23N	164-06.06W	171.0	157.3	9.5	159.0	160.2	021M01	CTD/R

022	1	091010	12:07	14:12	71-57.80N	150-14.00W	3018.0	3006.9	9.2	3000.6	3053.5	022M01	CTD/R
023	1	091010	18:52	20:30	71-39.54N	151-13.97W	2021.0	2015.9	8.5	2009.1	2039.8	023M01	CTD/R
024	1	091010	23:13	00:15	71-30.09N	151-39.44W	997.0	986.9	9.4	986.1	998.7	024M01	CTD/R
025	1	091110	01:47	02:29	71-27.28N	151-48.51W	430.0	415.4	10.1	416.9	421.6	025M01	CTD/R
026	1	091110	04:39	04:52	71-22.04N	152-07.15W	64.8	52.9	10.0	54.5	55.1	026M01	CTD/R
027	1	091110	17:37	17:58	71-43.57N	155-10.75W	282.0	269.9	9.8	270.6	273.7	027M01	CTD/2L
028	1	091210	20:56	21:37	71-44.07N	155-05.88W	246.0	234.8	-	236.8	238.8	028M01	CTD/R
029	1	091310	06:25	06:37	71-20.32N	157-59.12W	120.0	104.9	9.5	107.5	109.0	029M01	CTD/2L
030	1	091310	09:31	09:48	71-06.36N	159-19.39W	83.0	74.0	10.0	76.8	77.5	030M01	CTD/R
031	1	091310	14:17	14:26	71-00.03N	161-59.98W	45.0	32.7	10.0	35.0	35.3	031M01	CTD/R
032	1	091310	19:59	20:06	72-00.00N	161-59.82W	29.0	15.0	10.0	18.8	18.9	032M01	CTD/R
033	1	091410	01:57	02:12	72-59.95N	161-59.83W	112.0	96.1	10.0	98.5	99.5	033M01	CTD/R
034	1	091410	07:37	08:21	74-00.00N	161-59.73W	361.0	346.7	9.2	348.2	352.6	034M01	CTD/R
035	1	091610	12:22	14:19	78-15.51N	169-59.52W	2534.0	2523.3	9.8	2519.7	2561.1	035M01	CTD/R
036	1	091610	17:01	18:10	78-04.34N	169-20.51W	1186.0	1167.2	32.7	1166.0	1182.1	036M01	CTD/R
037	1	091610	20:03	20:53	77-51.02N	168-23.38W	497.0	481.8	10.1	484.2	489.7	037M01	CTD/R
038	1	091710	00:20	01:01	77-37.78N	167-28.40W	430.0	422.8	7.9	422.5	427.7	038M01	CTD/R
039	1	091710	16:06	17:54	75-59.99N	175-14.98W	2100.0	2089.4	9.9	2085.8	2118.4	039M01	CTD/R
040	1	091810	12:02	13:12	76-26.99N	179-35.99E	1156.0	1141.4	8.9	1139.9	1155.1	040M01	CTD/R
041	1	091810	16:17	17:23	76-00.06N	178-54.25E	1073.0	1060.4	9.8	1058.5	1072.2	041M01	CTD/R
042	1	091810	21:52	22:43	75-24.64N	178-12.73E	497.0	483.2	9.1	484.8	490.4	042M01	CTD/R
043	1	091910	00:54	01:34	75-13.99N	177-59.05E	352.0	335.7	9.7	336.3	340.5	043M01	CTD/R
044	1	091910	03:33	04:02	75-00.00N	177-43.09E	217.0	203.2	7.8	204.6	207.1	044M01	CTD/R
045	1	091910	06:58	07:17	74-59.87N	179-00.04E	261.0	252.4	9.1	254.6	257.6	045M01	CTD/2L
046	1	091910	08:57	09:38	74-59.90N	179-59.89E	397.0	377.2	9.0	380.2	384.6	046M01	CTD/R
047	1	091910	12:54	13:29	74-59.89N	178-00.33W	328.0	308.7	9.8	310.7	313.2	047M01	CTD/R
048	1	091910	16:30	17:00	74-59.99N	176-00.38W	260.0	249.5	9.1	251.1	254.2	048M01	CTD/R

049	1	091910	21:16	21:58	75-15.02N	174-00.68W	401.0	384.0	9.5	386.6	390.8	049M01	CTD/R
050	1	092010	00:51	01:21	74-59.98N	174-00.15W	304.0	287.2	9.8	288.0	291.5	050M01	CTD/R
051	1	092010	02:41	03:13	74-45.06N	174-00.21W	262.0	246.6	7.8	247.4	249.7	051M01	CTD/R
052	1	092010	06:17	06:48	74-59.97N	172-00.30W	384.0	370.6	9.3	372.0	376.1	052M01	CTD/R
053	1	092110	12:05	13:08	75-23.99N	174-00.14W	992.0	968.7	10.6	968.4	980.9	053M01	CTD/R
054	1	092110	14:36	15:54	75-35.02N	173-59.99W	1556.0	1537.8	9.2	1535.1	1557.3	054M01	CTD/R
055	1	092110	17:27	18:39	75-50.13N	173-59.96W	1997.0	1983.6	9.5	1978.8	2009.3	055M01	CTD/2L
056	1	092110	21:22	23:13	76-15.10N	173-59.56W	2229.0	2208.5	8.8	2207.7	2242.8	056M01	CTD/R
057	1	092210	04:13	04:50	76-40.02N	173-59.85W	2176.0	1086.0	-	1086.3	1100.0	057M01	CTD
058	1	092210	07:36	09:20	76-40.08N	171-59.85W	2270.0	2256.1	8.8	2250.5	2286.7	058M01	CTD/R
059	1	092210	13:26	14:06	76-40.02N	169-59.57W	2227.0	1101.9	-	1101.1	1114.2	059M01	CTD
060	1	092210	16:30	18:08	77-04.98N	169-59.90W	2218.0	2205.0	9.1	2201.7	2236.4	060M01	CTD/R
061	1	092210	20:27	21:31	77-08.17N	169-20.11W	1944.0	1934.5	8.5	1929.8	1959.1	061M01	CTD
062	1	092210	22:19	23:44	77-08.59N	168-55.95W	1669.0	1649.0	9.0	1647.6	1671.8	062M01	CTD/R
063	1	092310	01:22	02:21	77-10.51N	168-23.25W	934.0	914.0	9.3	914.8	926.0	063M01	CTD/R
064	1	092310	03:17	03:39	77-12.54N	167-54.17W	532.0	516.5	9.2	519.0	525.3	064M01	CTD
065	1	092310	06:22	07:14	77-15.78N	166-20.32W	822.0	800.6	9.5	800.2	809.7	065M01	CTD/R
066	1	092310	12:27	12:46	78-00.01N	164-59.49W	450.0	438.6	9.6	439.9	445.0	066M01	CTD
067	1	092310	15:39	16:03	78-29.96N	164-59.84W	606.0	596.6	8.8	596.3	603.5	067M01	CTD
068	1	092310	21:29	23:25	79-11.35N	164-58.48W	2425.0	2418.0	9.2	2413.1	2453.0	068M01	CTD/R
069	1	092410	01:19	02:05	78-57.99N	164-59.93W	2034.0	1002.2	-	1001.6	1014.9	069M01	CTD/2L
070	1	092410	02:58	04:21	78-52.04N	164-59.90W	1516.0	1520.4	7.6	1515.8	1537.8	070M01	CTD/R
071	1	092410	19:41	20:18	77-45.92N	163-47.10W	278.0	260.0	8.7	267.0	269.9	071M01	CTD/R
072	1	092410	22:46	00:46	77-45.43N	161-59.97W	2700.0	2719.9	8.6	2682.9	2728.7	072M01	CTD/R
073	1	092510	04:47	05:24	77-46.05N	160-00.47W	1836.0	1088.7	-	1086.5	1100.6	073M01	CTD
074	1	092510	07:50	08:23	77-22.16N	160-02.10W	849.0	842.8	7.4	842.7	853.4	074M01	CTD
075	1	092510	10:53	12:32	76-58.48N	160-04.22W	2043.0	2024.8	8.5	2024.3	2054.6	075M01	CTD/R

076	1	092510	15:15	15:58	76-47.42N	158-29.87W	1205.0	1087.4	-	1088.2	1101.4	076M01	CTD
077	1	092510	18:14	19:19	76-36.92N	157-00.78W	1064.0	1063.2	8.4	1067.2	1080.3	077M01	CTD/R
078	1	092610	06:40	08:55	76-23.52N	154-44.41W	3031.0	3143.8	8.3	3121.5	3178.4	078M01	CTD/R
079	1	092610	14:19	16:55	75-30.74N	155-16.78W	3854.0	3845.6	8.6	3831.8	3907.6	079M01	CTD/R
080	1	092610	19:06	19:48	75-36.83N	156-04.01W	2459.0	1092.0	-	1087.2	1100.7	080M01	CTD
081	1	092610	21:08	22:38	75-39.79N	156-17.02W	1494.0	1494.8	8.8	1494.2	1515.3	081M01	CTD/R
082	1	092710	03:22	04:19	75-44.81N	157-05.95W	974.0	961.6	7.6	962.0	974.5	082M01	CTD/R
083	1	092710	07:08	07:50	75-51.90N	158-05.05W	550.0	538.7	8.7	540.7	547.4	083M01	CTD/R
084	1	092710	20:50	21:05	74-00.17N	162-00.74W	363.0	347.4	7.5	354.2	357.7	084M01	CTD
085	1	092810	02:45	02:51	72-59.86N	161-59.64W	116.0	99.0	10.0	103.1	105.0	085M01	CTD
086	1	092810	14:42	14:52	71-00.02N	161-59.89W	45.0	28.8	10.0	34.5	34.7	086M01	CTD/R
087	1	092810	20:00	20:15	71-06.35N	159-19.39W	82.0	62.8	10.0	71.5	71.9	087M01	CTD/R
088	1	092910	00:13	00:21	71-14.94N	157-09.53W	47.0	34.5	10.0	37.7	37.8	088M01	CTD/R
089	1	092910	01:01	01:05	71-17.26N	157-14.83W	57.0	41.9	10.0	46.7	47.3	089M01	CTD
090	1	092910	01:37	01:42	71-19.79N	157-19.44W	92.0	75.3	10.0	80.3	80.6	090M01	CTD
091	1	092910	02:17	02:23	71-22.28N	157-24.74W	111.0	95.7	10.0	99.3	100.1	091M01	CTD
092	1	092910	02:54	03:11	71-24.79N	157-29.48W	126.0	108.7	10.0	11.2	113.7	092M01	CTD/R
093	1	092910	04:33	04:39	71-27.20N	157-34.79W	111.0	95.1	10.0	99.7	100.7	093M01	CTD
094	1	092910	05:11	05:16	71-29.73N	157-40.03W	86.0	69.0	10.0	74.5	75.6	094M01	CTD
095	1	092910	05:51	05:54	71-32.16N	157-45.29W	71.0	54.5	10.0	60.3	60.7	095M01	CTD
096	1	092910	06:26	06:37	71-34.63N	157-50.37W	64.0	51.0	10.0	54.0	54.8	096M01	CTD/R
097	1	092910	19:50	19:57	71-55.93N	155-39.10W	142.0	128.2	10.0	131.6	132.4	097M01	CTD
098	1	092910	20:42	20:50	71-51.99N	155-29.55W	158.0	140.0	8.0	145.1	147.0	098M01	CTD
099	1	092910	21:32	21:42	71-48.80N	155-17.31W	197.0	183.2	7.4	186.6	189.0	099M01	CTD
100	1	092910	22:15	22:28	71-45.84N	155-14.42W	236.0	212.7	9.3	216.1	218.8	100M01	CTD/CN
101	1	092910	23:01	23:12	71-43.98N	155-06.88W	251.0	240.9	8.7	243.0	245.9	101M01	CTD
102	1	092910	23:43	23:50	71-41.97N	155-03.31W	161.0	144.6	9.0	150.4	151.4	102M01	CTD

103	1	093010	00:14	00:19	71-40.86N	154-58.09W	109.0	96.6	10.0	98.0	99.2	103M01	CTD
104	1	093010	00:47	00:51	71-38.38N	154-55.34W	62.0	47.2	10.0	51.2	51.7	104M01	CTD
105	1	093010	01:22	01:30	71-36.05N	154-50.29W	42.0	28.8	10.0	32.0	32.4	105M01	CTD/R
106	1	093010	07:29	07:45	72-10.96N	157-10.88W	125.0	108.0	10.0	111.2	112.1	106M01	CTD/R
107	1	093010	13:35	13:45	72-30.00N	159-59.80W	47.0	34.7	10.0	36.7	37.4	107M01	CTD/R
108	1	093010	15:17	15:22	72-34.98N	159-41.84W	55.0	42.2	10.0	44.9	45.1	108M01	CTD
109	1	093010	16:19	16:32	72-40.97N	159-24.08W	76.0	63.5	10.0	65.9	66.4	109M01	CTD/R
110	1	093010	17:28	17:35	72-46.97N	159-06.18W	191.0	174.3	9.4	175.2	177.0	110M01	CTD
111	1	093010	18:53	19:33	72-52.97N	158-47.96W	358.0	341.4	9.2	342.4	346.4	111M01	CTD/R
112	1	093010	23:10	23:53	72-59.93N	158-30.09W	1277.0	1251.5	9.0	1256.9	1270.9	112M01	CTD
113	1	100110	02:37	04:22	73-09.02N	157-59.90W	2399.0	2389.5	8.1	2328.0	2421.3	113M01	CTD/R
114	1	100110	05:56	07:04	73-19.95N	157-28.41W	2991.0	2004.2	-	2000.6	2031.0	114M01	CTD/2L
115	1	100110	08:31	10:53	73-28.63N	156-59.57W	3316.0	3291.4	8.2	3289.7	3350.4	115M01	CTD/R
116	1	100110	15:11	17:41	74-04.33N	155-19.71W	3863.0	3843.0	8.4	3837.8	3913.4	116M01	CTD/R
117	1	100110	23:14	00:18	74-23.93N	157-00.38W	3861.0	1084.3	-	1086.3	1100.2	117M01	CTD/R
118	1	100210	02:10	02:49	74-34.51N	157-55.44W	1333.0	1088.2	-	1087.0	1100.6	118M01	CTD
119	1	100210	04:41	05:44	74-40.65N	158-18.86W	1168.0	1180.8	6.7	1150.1	1165.7	119M01	CTD/R
120	1	100210	07:30	08:12	74-47.99N	158-59.74W	1152.0	1085.2	31.9	1087.0	1100.8	120M01	CTD/2L
121	1	100210	23:03	23:37	74-22.75N	165-16.19W	361.0	345.0	9.1	347.0	351.1	121M01	CTD/R
122	1	100310	01:08	01:22	74-15.10N	166-00.12W	274.0	261.4	7.9	262.6	265.4	122M01	CTD
123	1	100310	02:43	03:05	74-06.76N	166-47.21W	215.0	196.6	11.0	198.2	200.4	123M01	CTD/R
124	1	100310	03:55	04:03	74-02.33N	167-14.21W	219.0	205.9	7.2	206.8	208.9	124M01	CTD
125	1	100310	04:51	05:10	73-58.94N	167-35.87W	207.0	187.2	9.7	188.7	190.9	125M01	CTD/R
126	1	100310	18:31	20:04	74-59.99N	162-00.22W	1974.0	1964.1	8.4	1960.1	1989.8	126M01	CTD/R
127	1	100410	12:05	12:25	75-44.97N	165-30.06W	505.0	492.8	9.0	494.1	500.1	127M01	CTD
128	1	100410	13:58	14:44	76-00.09N	165-29.94W	456.0	443.2	9.1	442.6	448.0	128M01	CTD/R
129	1	100410	20:41	22:08	76-37.45N	168-04.80W	1806.0	1794.3	7.4	1790.1	1816.9	129M01	CTD/R

130	1	100410	23:32	00:10	76-33.92N	167-26.24W	1101.0	1087.8	6.9	1085.7	1100.1	130M01	CTD
131	1	100510	01:15	02:01	76-30.99N	166-51.82W	607.0	591.8	9.3	593.0	600.3	131M01	CTD/R
132	1	100510	04:14	04:56	76-26.51N	165-48.99W	1094.0	1082.5	5.3	1081.7	1096.0	132M01	CTD/2L
133	1	100510	06:34	07:10	76-15.75N	164-58.49W	457.0	446.3	8.8	448.4	453.2	133M01	CTD/R
134	1	100510	09:41	10:19	75-56.54N	163-47.19W	1019.0	1019.2	8.7	1020.1	1033.2	134M01	CTD
135	1	100510	12:06	13:42	75-44.23N	162-56.73W	2040.0	2030.6	7.8	2027.4	2058.3	135M01	CTD/R
136	1	100510	18:17	19:06	75-00.02N	163-36.10W	1531.0	1522.0	7.2	1518.6	1540.5	136M01	CTD
137	1	100510	21:10	22:02	75-00.02N	165-00.61W	544.0	529.0	9.8	530.7	536.2	137M01	CTD/R
138	1	100510	23:57	00:15	75-00.00N	166-00.31W	486.0	472.6	9.2	473.0	477.9	138M01	CTD
139	1	100610	02:00	02:32	75-00.23N	167-13.94W	260.0	242.0	8.8	243.7	246.3	139M01	CTD/R
140	1	100610	04:16	04:36	75-00.01N	167-59.98W	170.0	155.4	9.8	157.1	158.9	140M01	CTD/R
141	1	100610	06:05	06:16	75-00.03N	169-00.16W	215.0	204.8	5.8	206.2	208.1	141M01	CTD
142	1	100610	07:46	08:14	74-59.97N	170-00.24W	258.0	246.9	9.2	248.6	251.7	142M01	CTD/R
143	1	100610	23:13	23:37	73-42.81N	162-45.80W	195.0	181.9	7.3	184.7	186.5	143M01	CTD/R
144	1	100710	04:13	04:30	73-03.43N	163-44.70W	101.0	88.9	10.0	90.8	91.8	144M01	CTD/R
145	1	100710	08:47	08:54	73-19.56N	161-59.45W	168.0	153.2	9.4	155.7	157.6	145M01	CTD
146	1	100710	10:54	11:33	73-28.79N	160-59.84W	375.0	357.9	9.3	360.0	364.2	146M01	CTD/R
147	1	100710	13:51	15:07	73-38.08N	160-00.11W	2276.0	2254.8	8.8	2251.2	2286.5	147M01	CTD
148	1	100710	17:02	19:13	73-47.42N	159-00.06W	3149.0	3120.3	8.6	3144.9	3171.2	148M01	CTD/R
149	1	100810	00:24	01:38	73-43.22N	156-41.06W	3573.0	1188.7	-	1185.0	1200.4	149M01	CTD/R
150	1	100810	05:57	07:04	73-35.41N	157-39.11W	3172.0	1088.0	-	1086.0	1100.8	150M01	CTD/R
151	1	100810	10:28	11:46	73-44.67N	158-25.82W	3271.0	1090.4	-	1088.4	1102.6	151M01	CTD/R
152	1	100810	14:06	14:45	73-49.40N	158-49.35W	3272.0	1089.1	-	1087.7	1102.0	152M01	CTD
153	1	100810	15:53	16:58	73-54.08N	159-13.11W	3191.0	1090.9	-	1086.9	1101.2	153M01	CTD/R
154	1	100910	00:23	02:56	74-01.01N	157-30.18W	3847.0	3839.2	6.9	3828.1	3903.4	154M01	CTD/R
155	1	100910	08:31	09:45	73-54.07N	158-15.08W	3584.0	1088.2	-	1086.4	1100.4	155M01	CTD/R
156	1	100910	14:08	15:16	73-42.89N	159-30.56W	2749.0	1088.7	-	1086.6	1100.8	156M01	CTD/R

157	1	100910	18:11	19:15	73-57.63N	159-30.25W	2258.0	1091.5	-	1087.0	1101.1	157M01	CTD/R
158	1	100910	21:54	22:42	74-11.12N	160-30.01W	536.0	518.9	8.8	520.6	526.4	158M01	CTD/R
159	1	101010	04:53	05:33	74-30.03N	164-29.56W	399.0	386.8	9.7	387.5	391.8	159M01	CTD/R
160	1	101010	07:17	08:19	74-37.39N	163-44.79W	1010.0	1002.7	6.3	1001.0	1014.3	160M01	CTD/R
161	1	101010	09:55	11:27	74-45.06N	162-59.75W	1564.0	1550.1	9.1	1547.5	1569.5	161M01	CTD/R
162	1	101010	20:18	20:55	74-00.10N	162-00.57W	361.0	348.9	9.0	349.2	353.6	162M01	CTD/R
163	1	101110	01:53	02:08	72-59.97N	161-59.85W	118.0	101.2	10.0	102.8	103.9	163M01	CTD/R
164	1	101110	14:08	14:18	70-59.96N	161-59.92W	45.0	32.8	10.0	35.3	35.7	164M01	CTD/R
165	1	101110	21:07	21:28	70-29.75N	164-45.30W	45.0	32.1	10.0	35.0	35.2	165M01	CTD/R
166	1	101210	03:11	03:21	69-59.94N	167-59.94W	47.0	35.1	10.0	37.6	37.7	166M01	CTD/R
167	1	101210	12:04	12:09	69-30.05N	168-49.88W	52.0	37.8	10.0	41.6	41.8	167M01	CTD
168	1	101210	14:31	14:43	68-59.98N	168-50.02W	51.0	37.6	10.0	41.1	42.0	168M01	CTD/R
169	1	101210	17:34	17:37	68-29.94N	168-49.93W	52.0	39.5	10.0	42.6	43.0	169M01	CTD
170	1	101210	19:57	20:09	67-59.97N	168-49.97W	57.0	44.6	10.0	46.9	47.7	170M01	CTD/R
171	1	101210	23:37	23:41	67-30.27N	168-49.17W	49.0	39.5	-	42.5	43.0	171M01	CTD
172	1	101310	02:34	02:44	67-00.09N	168-49.91W	47.0	30.8	10.0	35.9	36.2	172M01	CTD/R
173	1	101310	05:48	05:55	66-30.26N	168-49.61W	49.0	39.3	-	43.2	44.0	173M01	CTD
174	1	101310	16:03	16:13	66-00.05N	168-49.98W	53.0	40.6	10.0	42.7	43.1	174M01	CTD/R
175	1	101310	18:43	18:54	65-45.31N	168-29.86W	56.0	42.8	10.0	46.0	46.4	175M01	CTD/R
176	1	101310	21:36	21:40	65-49.13N	168-49.90W	49.0	35.4	10.0	38.7	38.9	176M01	CTD
177	1	101310	23:21	23:25	65-42.40N	168-15.00W	44.0	34.7	-	38.0	38.4	177M01	CTD

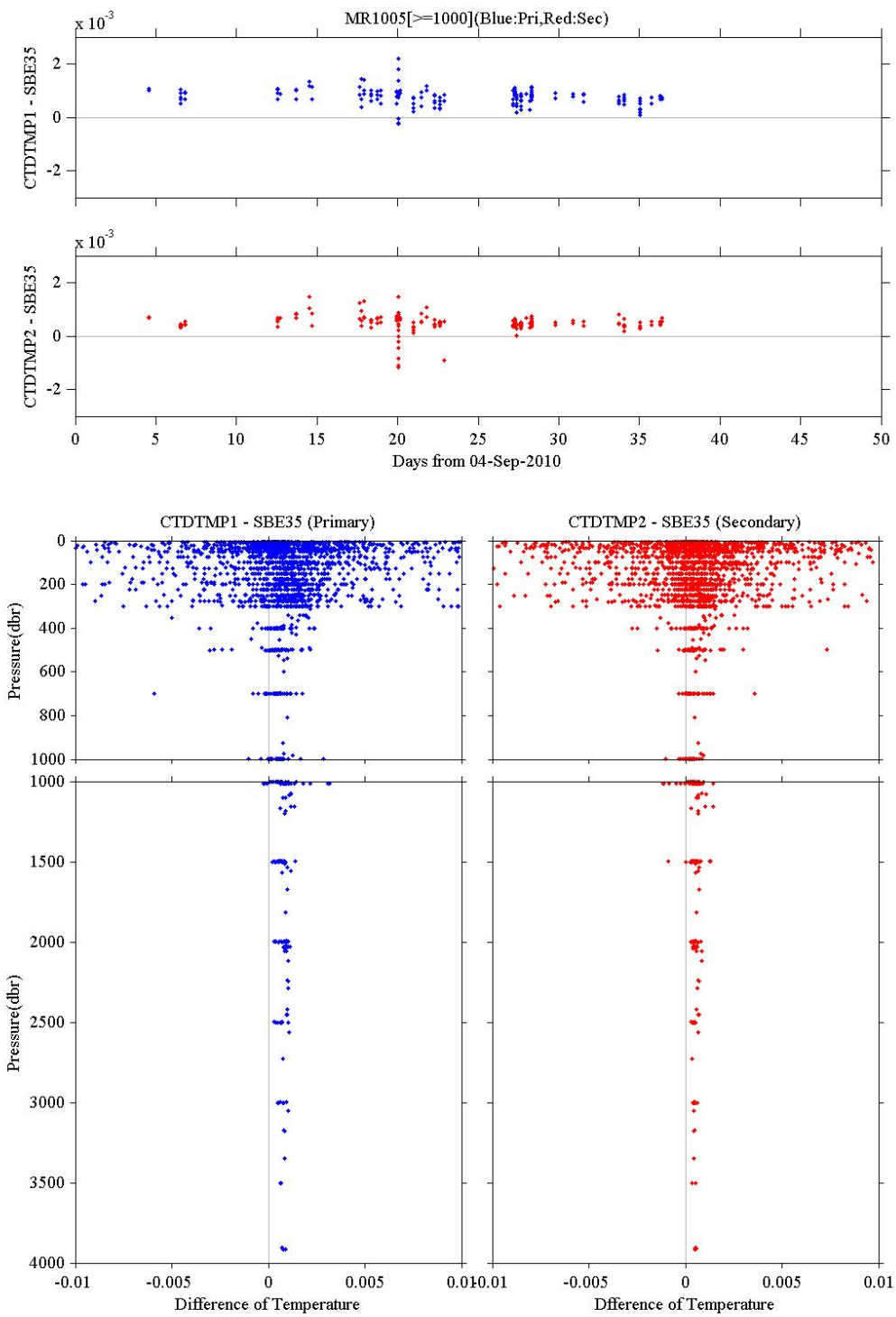

Fig. 3.1-1. Time drift and the difference between CTD temperature and SBE35.

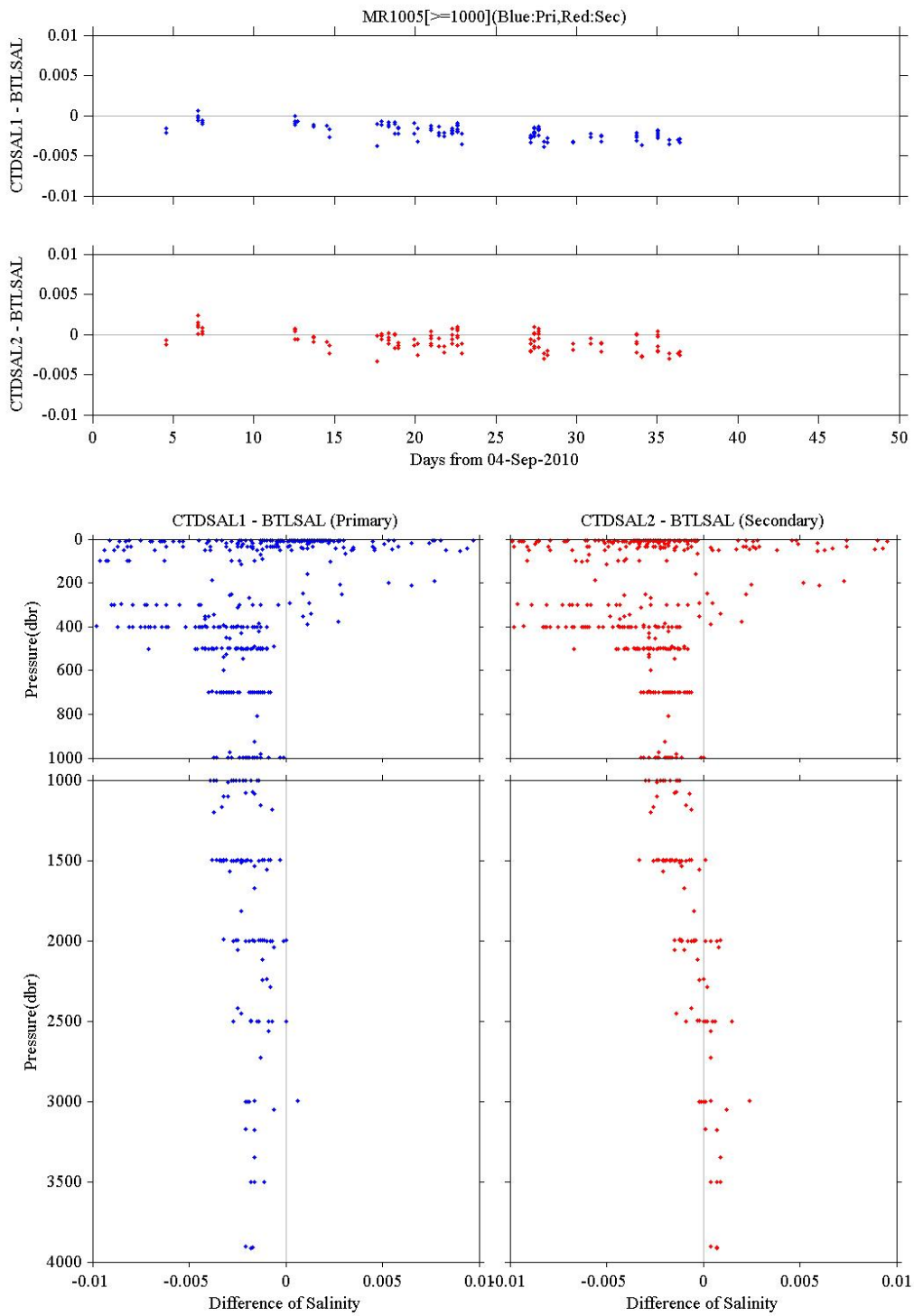

Fig. 3.1-2. Time drift and the difference between CTD salinity and BTL salinity.

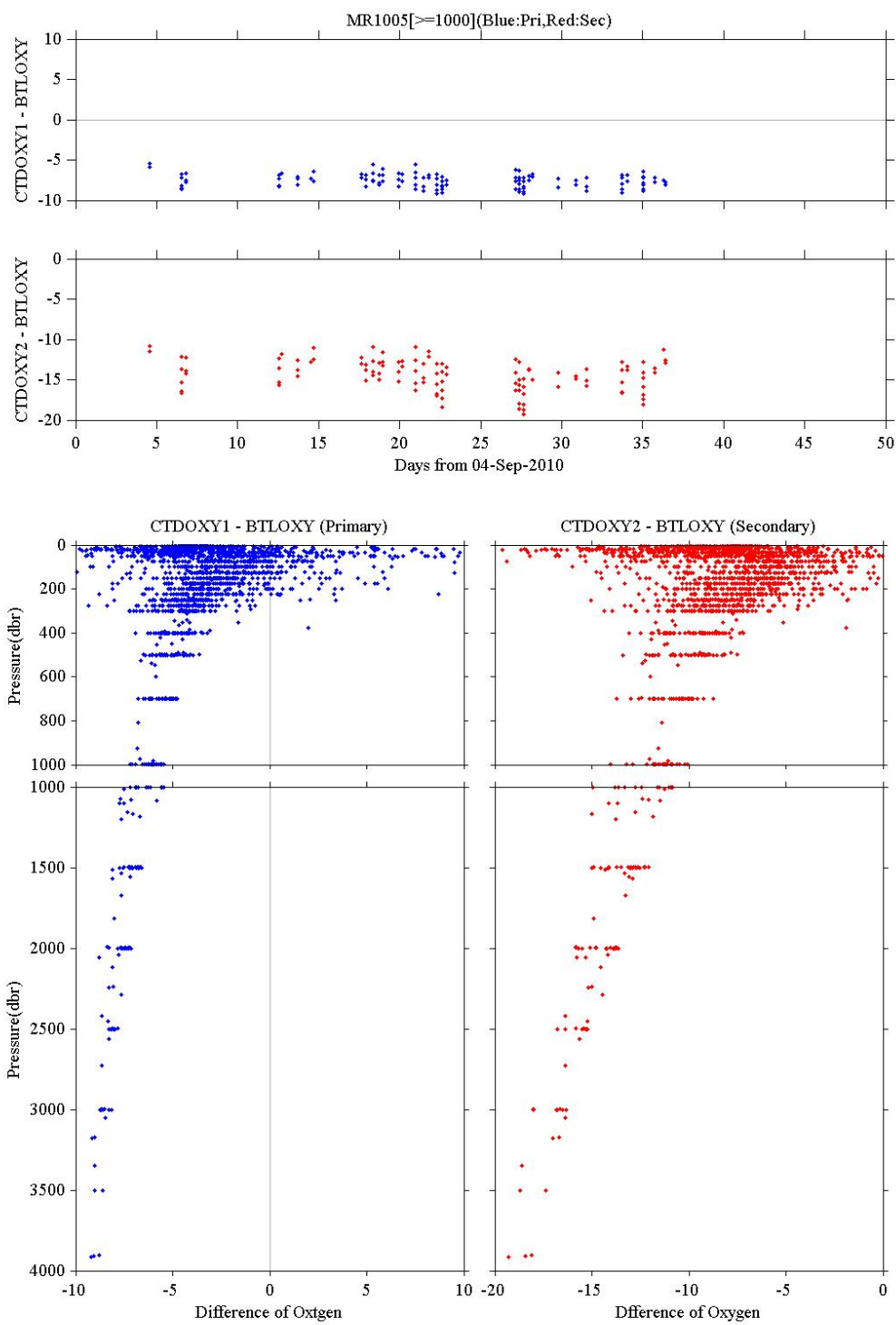

Fig. 3.1-3. Time drift and the difference between CTD oxygen and BTL oxygen.

3.2. Salinity measurement of sampled water

(1) Personnel

Shigeto Nishino (JAMSTEC): Principal Investigator
Motoyo Itoh (JAMSTEC)
Tatsuya Tanaka (MWJ)

(2) Objective

To provide calibrations for the measurements of salinity collected from CTD and TSG (Underway surface water monitoring).

(3) Parameters

The specifications of the AUTOSAL salinometer are shown as follows ;

Salinometer (Model 8400B “AUTOSAL” ; Guildline Instruments Ltd.)

Measurement Range : 0.005 to 42 (PSU)

Accuracy : Better than ± 0.002 (PSU) over 24 hours
without re-standardization

Maximum Resolution : Better than ± 0.0002 (PSU) at 35 (PSU)

(4) Instruments and Methods

a. Salinity Sample Collection

Seawater samples were collected with 12 liter Niskin-X bottles, bucket, and TSG. The salinity sample bottle of 250ml brown glass with screw cap was used for collecting the sample water. Each bottle was rinsed 3 times with the sample water, and was filled with sample water to the bottle shoulder. All of sample bottles for TSG and for shallower than 100dbar were sealed with a plastic insert thimble and a screw cap because we took into consideration the possibility of storage for about a month. The thimble was rinsed 3 times with the sample water before use. The bottle was stored for more than 24 hours in the laboratory before the salinity measurement.

Types and numbers (n) of the samples are shown in Table 3.2-1.

Table 3.2-1. Types and numbers (n) of samples

Types	n
Samples for CTD and bucket	1296
Samples for TSG	42
Total	1338

b. Instruments and Method

The salinity analysis was carried out on R/V MIRAI during the cruise of MR10-05 Leg2 using the salinometer (Model 8400B “AUTOSAL” ; Guildline

Instruments Ltd.: S/N 62827 and S/N 62556) with an additional peristaltic-type intake pump (Ocean Scientific International, Ltd.). S/N 62827 was used to measure samples shallower than 100dbar and TSG. S/N 62556 was used for samples from 100 dbar or deeper.

Two pair of precision digital thermometers (Model 9540 ; Guildline Instruments Ltd.) were used. The thermometer monitored the ambient temperature and the other monitored a bath temperature.

The specifications of the thermometer are shown as follows ;

Thermometer (Model 9540 ; Guildline Instruments Ltd.)

Measurement Range : -40 to +180 deg C

Resolution : 0.001

Limits of error \pm deg C : 0.01 (24 hours @ 23 deg C \pm 1 deg C)

Repeatability : \pm 2 least significant digits

The measurement system was almost the same as Aoyama *et al.* (2002). The salinometer was operated in the air-conditioned ship's laboratory at a bath temperature of 24 deg C. The ambient temperature varied from approximately 21 deg C to 25 deg C, while the bath temperature was very stable and varied within \pm 0.002 deg C on rare occasion.

The measurement for each sample was done with a double conductivity ratio and defined as the median of 31 readings of the salinometer. Data collection was started 10 seconds after filling the cell with the sample and it took about 15 seconds to collect 31 readings by a personal computer. Data were taken for the sixth and seventh filling of the cell after rinsing 5 times. In the case of the difference between the double conductivity ratio or the salinity of these two fillings being smaller than the criteria* we decided, the average value of the double conductivity ratio was used to calculate the bottle salinity with the algorithm for the practical salinity scale, 1978 (UNESCO, 1981). If the difference was greater than or equal to the criteria, an eighth filling of the cell was done. In the case of the difference between these two fillings of the double conductivity ratio or the salinity being smaller than the criteria, the average value of the double conductivity ratio was used to calculate the bottle salinity. In the case of the double conductivity ratio of eighth filling did not satisfy the criteria above, the operator measured a ninth and tenth filling of the cell and calculated the bottle salinity above. The cell was cleaned with soap after the measurement of the day.

*criteria:

for samples from 100 dbar or deeper: 0.00002 in double conductivity ratio

for samples shallower than 100dbar and TSG : 0.001 in salinity

(5) Results

a. Standard Seawater (SSW)

The specifications of SSW used in this cruise are shown as follows ;

<For standardization>

Batch : P152
conductivity ratio : 0.99981
salinity : 34.993
preparation date : 5th May 2010

Batch : P150
conductivity ratio : 0.99978
salinity : 34.991
preparation date : 22nd May 2008

<For check of the linearity for the salinometer (Linearity Pack)>

Batch : 38H10
conductivity ratio : 1.07562 (at 24 deg C)
salinity : 37.997
preparation date : 1st Oct 2008

Batch : 30L14
conductivity ratio : 0.87154 (at 24 deg C)
salinity : 30.003
preparation date : 29th Sep 2008

Batch : 10L11
conductivity ratio : 0.32060 (at 24 deg C)
salinity : 9.998
preparation date : 23rd July 2008

Standardization control of the salinometer S/N 62827 was set to 447 (5 Sep.). The value of STANDBY was 5380 +/- 0003 and that of ZERO was 0.0+0001 +/- 0001. SSW (P150) was used as the standard for salinity. 20 bottles of SSW were measured (3 bad bottles were excluded). SSW (Linearity Pack) was used to check the linearity of the salinometer within the measurement range. The difference between the certificated value and the measurement value was 0.000 +/- 0.001, the salinometer showed the linearity sufficiently.

Standardization control of the salinometer S/N 62556 was set to 749 (4 Sep.)

and measurements were done at this setting before 26 Sep. The value of STANDBY was 5468 +/- 0002 and that of ZERO was 0.0-0000 +/- 0001. Because the salinometer drifted - 0.00007 of the double conductivity ratio, standardization control was set to 760 (27 Sep.) and measurements were done at this setting before 13 Oct. The value of STANDBY was 5474 +/- 0001 and that of ZERO was 0.0-0000 +/- 0001. SSW (P152) was used as the standard for salinity. SSW was measured 20 bottles before 26 Sep. and 20 bottles after 27 Sep.

Figure 3.2-1 shows the history of the double conductivity ratio of the Standard Seawater batch P152 measured by S/N 62556 before correction. The average of the double conductivity ratio before 26 Sep. was 1.99958 and the standard deviation was 0.00003, which is equivalent to 0.0005 in salinity. The average of the double conductivity ratio after 27 Sep. was 1.99961 and the standard deviation was 0.00001, which is equivalent to 0.0003 in salinity.

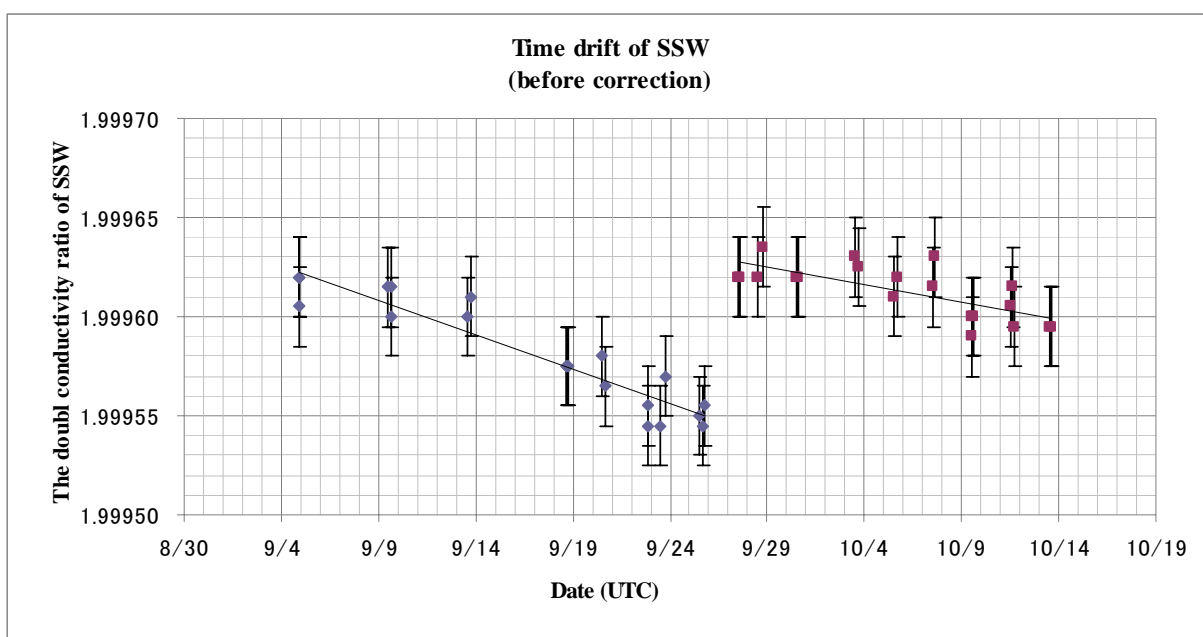

Fig. 3.2-1. History of double conductivity ratio for the Standard Seawater batch P152 (S/N 62556: before correction).

Figure 3.2-2 shows the history of the double conductivity ratio of the Standard Seawater batch P152 measured by S/N 62556 after correction. The average of the double conductivity ratio after correction before 26 Sep. was 1.99962 and the standard deviation was 0.00001, which is equivalent to 0.0001 in salinity. The average of the double conductivity ratio after correction after 27 Sep. was 1.99962 and the standard deviation was 0.00001, which is equivalent to 0.0001 in salinity.

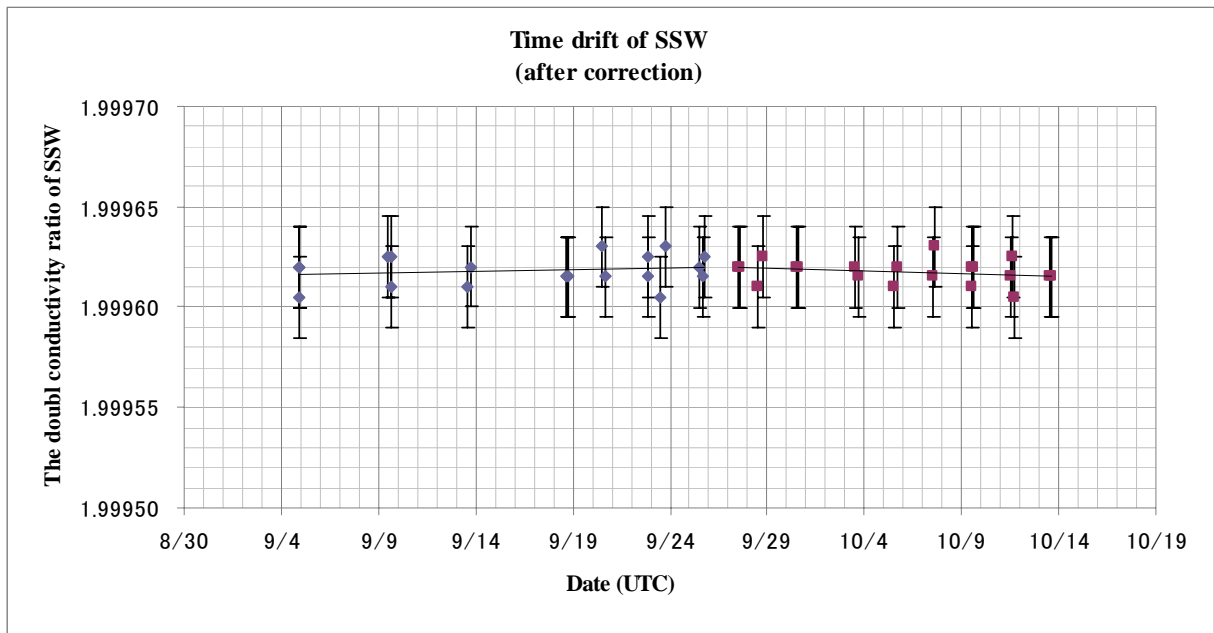

Fig. 3.2-2. History of double conductivity ratio for the Standard Seawater batch P152 (S/N 62556: after correction).

Figure 3.2-3 shows the history of the double conductivity ratio of the Standard Seawater batch P150 measured by S/N 62827. The average of the double conductivity ratio was 1.99953 and the standard deviation was 0.00003, which is equivalent to 0.0006 in salinity.

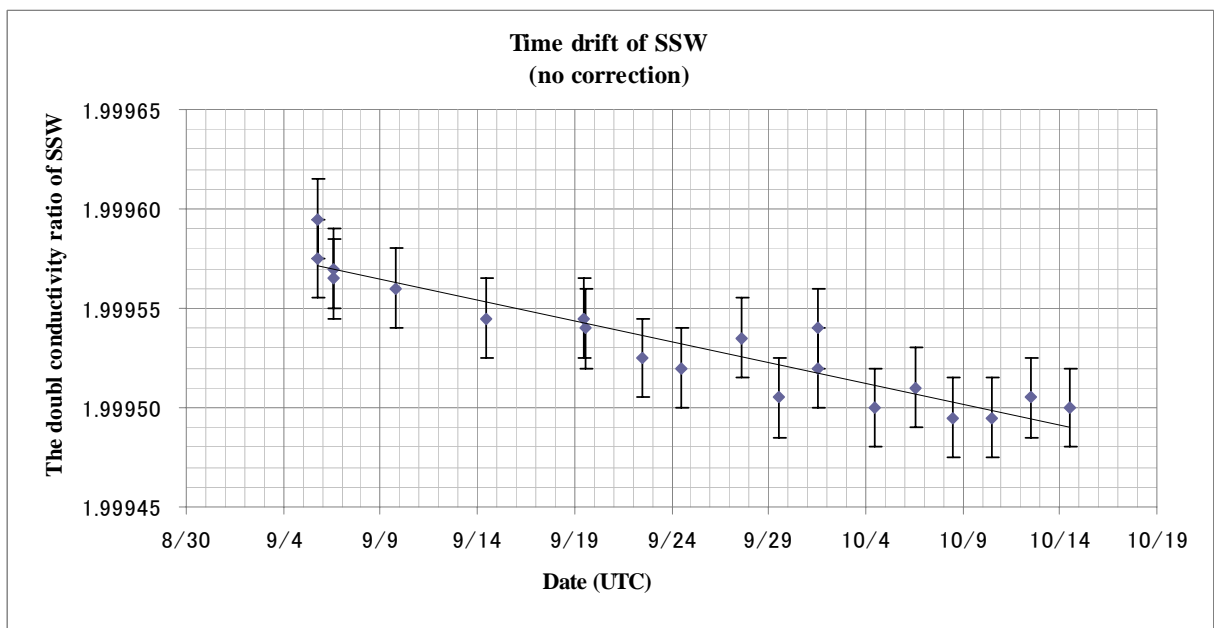

Fig. 3.2-3. History of double conductivity ratio for the Standard Seawater batch P150 (S/N 62827: no correction).

b. Sub-Standard Seawater

Sub-standard seawater was made from deep-sea water filtered by a pore size of 0.45 micrometer and stored in a 20 liter container made of polyethylene and stirred for at least 24 hours before measuring. It was measured about every 6 samples in order to check for the possible sudden drifts of the salinometer.

c. Replicate Samples

We estimated the precision of this method using 80 pairs of replicate samples taken from the same Niskin bottle. The average and the standard deviation of absolute difference among 78 pairs except 2 bad pairs were 0.0003 and 0.0003 in salinity, respectively.

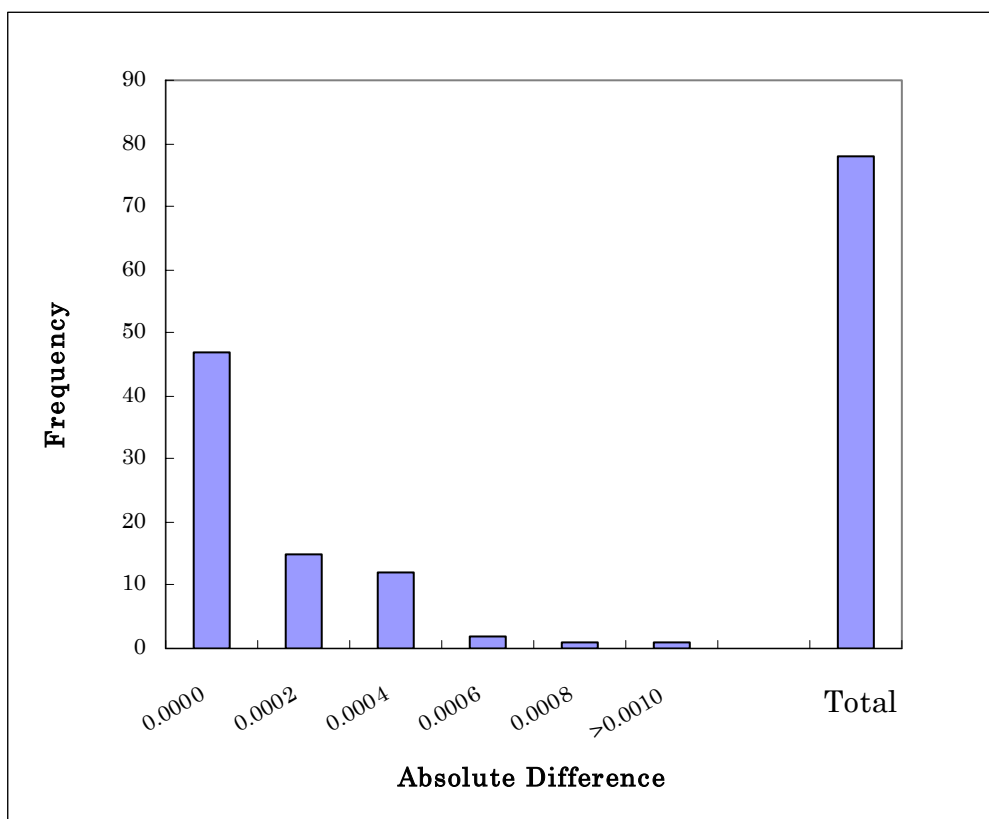

Fig. 3.2-4. Absolute difference of replicate samples.

d. Data Correction for Samples

For samples from 100 dbar or deeper, the data were corrected according to the result of the correction for SSW measured by S/N 62556. For samples shallower than 100dbar and TSG, the data were not corrected.

(6) Data archives

a. Data Policy

These raw datasets will be submitted to JAMSTEC Data Management Office (DMO) and corrected datasets are available from Mirai Web site.

b. Citation

- Aoyama, M., T. Joyce, T. Kawano and Y. Takatsuki : Standard seawater comparison up to P129. Deep-Sea Research, I, Vol. 49, 1103~1114, 2002
- UNESCO : Tenth report of the Joint Panel on Oceanographic Tables and Standards. UNESCO Tech. Papers in Mar. Sci., 36, 25 pp., 1981

3.3. XCTD observation

(1) Personnel

Motoyo Itoh	JAMSTEC: Principal Investigator
Norio Nagahama	Global Ocean Development Inc.: GODI
Satoshi Okumura	GODI
Souichiro Sueyoshi	GODI
Asuka Doi	GODI
Wataru Tokunaga	MIRAI Crew

(2) Objective

XCTD observations were performed between CTD stations and were substituted for CTD.

(3) Parameters

According to the manufacturer's nominal specifications, the range and accuracy of parameters measured by the XCTD (eXpendable Conductivity, Temperature & Depth profiler) are as follows;

<u>XCTD-1</u>	<u>Parameter</u>	<u>Range</u>	<u>Accuracy</u>
	Conductivity	0 ~ 60 [mS/cm]	+/- 0.03 [mS/cm]
	Temperature	-2 ~ 35 [deg-C]	+/- 0.02 [deg-C]
	Depth	0 ~ 1000 [m]	5 [m] or 2 [%] (either of them is major)

<u>XCTD-2</u>	<u>Parameter</u>	<u>Range</u>	<u>Accuracy</u>
	Conductivity	10 ~ 60 [mS/cm]	+/- 0.03 [mS/cm]
	Temperature	-2 ~ 35 [deg-C]	+/- 0.02 [deg-C]
	Depth	0 ~ 1850 [m]	5 [m] or 2 [%] (either of them is major)

(4) Methods

We observed the vertical profiles of the sea water temperature and salinity measured by XCTD-1 and XCTD-2. The signal was converted by digital converter MK-130 and was recorded by MK-130 software (Ver.3.11). Above system was manufactured by Tsurumi-Seiki Co.. We cast 168 probes by automatic and hand launcher.

(5) Observation log

Table3.3-1 XCTD observation log

Station No.	Date [YYYY/MM/DD]	Time [hh:mm]	Latitude [degN]	Longitude [degW]	Depth [m]	SST [deg-C]	SSS [PSU]	Probe S/N	
1	X001	2010/09/06	02:35	70-00.07	167-59.30	-	7.595	31.600	08069628
2	X002	2010/09/06	05:45	70-29.93	167-58.65	46	5.892	30.394	10027244
3	X003	2010/09/06	11:17	71-30.04	168-01.32	-	6.131	30.660	10027240
4	X004	2010/09/06	17:24	72-29.95	167-59.33	46	5.038	31.337	05032435
5	X005	2010/09/06	23:13	73-30.18	168-00.75	102	2.320	28.627	08069625
6	X006	2010/09/07	05:20	74-30.11	167-59.69	275	2.318	27.435	05032434
7	X007	2010/09/07	11:20	74-47.77	169-29.97	211	1.384	27.187	10027247
8	X008	2010/09/08	04:11	74-33.04	169-48.06	119	1.260	27.236	10027243
9	X009	2010/09/08	05:49	74-30.97	168-35.41	211	1.931	27.126	10027242
10	X010	2010/09/08	07:11	74-27.29	167-23.97	304	2.595	27.920	10024246
11	X011	2010/09/08	08:35	74-24.08	166-12.01	312	2.507	27.661	10027245
12	X012	2010/09/08	09:59	74-21.17	164-59.96	344	3.363	28.761	10027239
13	X013	2010/09/08	11:38	74-16.99	163-47.04	410	3.544	28.759	10027250
14	X014	2010/09/08	16:43	74-07.99	162-53.67	407	3.815	29.392	10027241
15	X015	2010/09/08	19:34	73-53.44	163-32.02	248	3.302	28.923	10027249
16	X016	2010/09/08	23:40	73-33.36	162-59.96	165	2.949	28.963	10027168
17	X017	2010/09/09	00:53	73-29.31	161-59.98	198	3.399	29.073	10027172
18	X018	2010/09/09	02:28	73-24.20	161-00.00	340	3.862	28.843	10027248
19	X019	2010/09/09	03:25	73-19.00	159-59.97	1366	3.775	28.750	10027173
20	X020	2010/09/09	04:51	73-07.43	159-04.98	1244	3.705	28.685	10027167
21	X021	2010/09/09	06:20	72-54.94	158-10.00	1459	2.965	29.650	10027171
22	X022	2010/09/09	07:46	72-42.56	157-14.98	1179	5.182	30.265	10027170
23	X023	2010/09/09	08:58	72-32.74	156-30.00	1463	5.286	30.472	10027169
24	X024	2010/09/09	10:33	72-19.95	155-35.02	1330	3.534	28.703	10027175
25	X025	2010/09/09	12:11	72-07.46	154-39.99	1096	5.823	30.166	10027174
26	X026	2010/09/10	17:50	71-44.61	150-47.28	2276	4.652	25.156	10037320
27	X027	2010/09/10	22:16	71-36.92	151-22.00	1768	4.579	25.335	10027176
28	X028	2010/09/11	02:59	71-23.91	151-59.97	157	3.362	27.039	10027177
29	X029	2010/09/12	07:06	71-36.57	154-50.82	38	7.679	31.055	10037322
30	X030	2010/09/12	07:20	71-38.51	154-55.32	57	8.073	31.071	10037319
31	X031	2010/09/12	07:32	71-40.26	154-59.71	109	8.085	31.035	10037317
32	X032	2010/09/12	07:43	71-41.88	155-04.13	161	5.930	30.347	10037315
33	X033	2010/09/12	07:54	71-54.39	155-08.63	248	5.228	29.790	10027178
34	X034	2010/09/12	08:08	71-45.48	155-14.46	238	5.058	29.672	10037316
35	X035	2010/09/12	08:21	71-47.47	155-19.75	175	4.623	29.382	10037321
36	X036	2010/09/12	08:46	71-51.36	155-29.69	148	4.551	29.468	10037318
37	X037	2010/09/12	09:10	71-55.05	155-38.96	140	4.508	29.500	10037314
38	X038	2010/09/12	18:42	71-47.85	155-18.70	187	4.538	29.397	10037312

Table3.3-1 Continued

39	X039	2010/09/12	19:49	71-41.04	154-57.38	108	6.468	30.628	10037311
40	X040	2010/09/13	02:45	71-35.22	155-56.54	207	5.213	29.687	10037274
41	X041	2010/09/13	17:20	71-30.00	161-59.98	39	4.555	29.275	10037270
42	X042	2010/09/13	23:20	72-30.00	161-59.04	70	4.558	30.216	10037269
43	X043	2010/09/14	05:18	73-30.00	161-59.22	200	3.576	29.183	10037271
44	X044	2010/09/14	11:15	74-29.99	161-56.88	1646	3.197	28.076	10037313
45	X045	2010/09/14	15:48	75-07.91	161-47.36	2065	2.935	25.847	10037273
46	X046	2010/09/14	17:35	75-29.84	162-33.81	2061	2.221	25.850	10037266
47	X047	2010/09/14	19:29	75-55.09	163-13.18	2062	1.206	25.849	10037272
48	X048	2010/09/14	20:34	76-07.43	163-30.06	709	1.765	26.219	10037267
49	X049	2010/09/14	21:30	76-19.85	163-58.20	937	1.756	26.502	10037310
50	X050	2010/09/14	23:33	76-44.86	164-52.82	408	0.714	26.436	10037309
51	X051	2010/09/15	01:30	77-04.99	165-47.74	830	0.462	26.316	10037263
52	X052	2010/09/15	02:33	77-14.99	166-22.99	804	0.435	26.250	10037265
53	X053	2010/09/15	03:29	77-26.06	166-53.50	572	0.178	25.977	10037268
54	X054	2010/09/15	05:30	77-46.85	168-07.36	486	-0.777	26.288	10037264
55	X055	2010/09/15	17:30	78-19.50	169-53.92	2270	-1.264	27.176	10037308
56	X056	2010/09/15	19:30	78-34.48	169-43.47	2303	-1.275	27.346	10037306
57	X057	2010/09/17	03:34	77-04.93	168-16.32	1311	-0.712	26.330	10037301
58	X058	2010/09/17	04:08	76-59.10	168-30.28	1791	-0.737	26.263	10037300
59	X059	2010/09/17	05:28	76-42.64	169-11.86	2201	-0.931	26.265	10037299
60	X060	2010/09/17	07:34	76-17.11	170-18.54	2159	-0.561	26.204	10037304
61	X061	2010/09/17	09:30	76-00.12	171-18.24	1743	-0.830	26.018	10037303
62	X062	2010/09/17	11:33	76-00.16	172-50.39	2036	-0.715	26.011	10037305
63	X063	2010/09/17	13:51	75-59.98	174-16.40	2161	-0.648	26.252	10037302
64	X064	2010/09/18	03:30	76-05.04	175-57.98	2032	-0.987	26.366	10037290
65	X065	2010/09/18	04:43	76-10.87	177-07.98	1384	-0.591	23.855	10037287
66	X066	2010/09/18	06:02	76-16.80	178-22.02	881	-0.907	26.593	10037289
67	X067	2010/09/18	07:13	76-21.56	179-17.97	1074	-0.700	27.036	10037288
68	X068	2010/09/18	14:57	76-12.01	-179-12.25	1196	-0.834	26.909	10037307
69	X069	2010/09/18	19:57	75-36.99	-178-27.65	720	-0.497	27.559	10037291
70	X070	2010/09/19	11:22	74-59.46	178-59.99	377	-0.269	28.146	10037295
71	X071	2010/09/19	14:55	75-00.07	176-59.99	257	0.096	27.532	10037293
72	X072	2010/09/19	19:32	75-07.69	175-00.12	312	0.052	26.427	10037292
73	X073	2010/09/20	04:55	74-52.79	172-59.98	326	0.611	27.002	10037298
74	X074	2010/09/20	08:07	74-47.99	171-29.69	292	1.271	27.527	10037294
75	X075	2010/09/21	19:48	76-02.77	174-00.27	2157	-0.537	26.293	10037297
76	X076	2010/09/22	03:00	76-27.50	173-59.95	2229	-0.765	26.285	09064540
77	X077	2010/09/22	06:11	76-39.87	172-59.74	2244	-1.150	26.206	09064537
78	X078	2010/09/22	11:55	76-35.40	170-59.92	2231	-0.985	26.225	10037196
79	X079	2010/09/22	15:15	76-52.49	169-59.79	2226	-0.977	26.342	08069623

Table3.3-1 Continued

80	X080	2010/09/23	05:09	77-14.29	149-07.01	586	0.201	26.369	09064466
81	X081	2010/09/23	10:10	77-37.00	165-44.89	450	-0.008	26.225	09064543
82	X082	2010/09/23	17:33	78-44.81	165-02.15	772	-1.312	26.744	08069627
83	X083	2010/09/23	20:28	79-09.24	165-00.32	2304	-1.382	27.180	09064541
84	X084	2010/09/24	07:26	78-44.31	164-56.94	763	-1.279	26.733	09064539
85	X085	2010/09/24	08:30	78-32.02	164-53.69	664	-1.113	26.620	09064544
86	X086	2010/09/24	10:11	78-11.99	165-00.04	501	-0.804	26.444	09064536
87	X087	2010/09/24	11:30	77-56.14	164-57.84	357	-0.227	26.209	09064538
88	X088	2010/09/24	14:29	77-50.31	165-09.35	481	-0.155	26.241	10027150
89	X089	2010/09/24	17:29	77-48.96	165-01.60	458	-0.193	26.218	08069624
90	X090	2010/09/24	21:37	77-45.88	162-45.97	541	-0.649	26.173	10027144
91	X091	2010/09/24	21:52	77-45.91	162-31.97	1655	-0.713	26.035	10027147
92	X092	2010/09/25	02:30	77-45.11	161-43.17	2706	-0.935	26.017	10027145
93	X093	2010/09/25	03:20	77-45.60	161-00.00	563	-0.942	26.003	10027148
94	X094	2010/09/25	14:01	76-52.93	159-16.98	2113	-0.937	25.382	10027151
95	X095	2010/09/25	16:59	76-42.39	157-45.02	1118	-0.534	25.439	10027154
96	X096	2010/09/25	22:22	76-33.44	156-15.03	1377	-1.022	24.763	10027152
97	X097	2010/09/25	23:34	76-29.86	155-31.87	1108	0.176	24.962	10027149
98	X098	2010/09/25	23:38	76-29.92	155-32.15	1100	0.174	24.962	10027153
99	X099	2010/09/26	01:15	76-22.42	154-35.89	3848	-1.257	24.754	10027208
100	X100	2010/09/26	11:23	75-55.27	154-45.73	3851	0.801	25.346	10027212
101	X101	2010/09/27	11:12	75-26.00	156-03.78	1501	0.240	25.673	10027213
102	X102	2010/09/27	14:27	75-00.11	162-01.12	1970	0.625	26.326	10027146
103	X103	2010/09/27	17:41	74-27.72	161-58.76	1570	1.289	27.953	10027143
104	X104	2010/09/27	23:27	73-29.99	162-00.45	197	2.302	28.320	10027211
105	X105	2010/09/28	05:30	72-29.53	161-58.70	35	2.933	31.246	10027210
106	X106	2010/09/28	08:27	71-59.98	162-00.31	22	3.403	30.335	10027269
107	X107	2010/09/28	11:28	71-29.98	162-00.19	40	3.015	29.619	10027203
108	X108	2010/09/30	06:06	72-04.32	156-30.02	141	2.033	29.097	10027205
109	X109	2010/09/30	11:16	72-22.14	158-44.98	46	2.391	30.395	10027204
110	X110	2010/10/01	12:09	73-38.00	156-30.78	3660	0.654	25.693	10027207
111	X111	2010/10/01	13:06	73-46.99	156-08.77	3674	0.386	25.628	10027165
112	X112	2010/10/01	14:06	73-56.00	155-43.52	3861	0.864	25.838	10027206
113	X113	2010/10/01	21:29	74-14.12	156-09.98	3858	0.787	25.690	10027164
114	X114	2010/10/02	01:24	74-29.19	157-27.50	3858	-0.573	25.231	10027166
115	X115	2010/10/02	10:25	74-42.16	160-30.01	1293	0.816	26.859	10027162
116	X116	2010/10/02	13:35	74-35.81	161-59.99	1759	0.768	26.100	10027159
117	X117	2010/10/02	14:19	74-30.62	163-17.00	1066	0.412	27.776	10027158
118	X118	2010/10/02	14:58	74-28.75	163-45.03	789	0.400	27.438	10027163
119	X119	2010/10/02	15:39	74-26.64	164-15.03	423	0.348	27.711	10027161
120	X120	2010/10/04	03:38	75-15.01	162-44.67	2026	0.338	26.413	09022851

Table3.3-1 Continued

121	X121	2010/10/04	05:25	75-29.96	163-29.83	1678	-0.079	26.362	09022848
122	X122	2010/10/04	06:44	75-30.32	164-25.52	664	0.036	26.510	10027160
123	X123	2010/10/04	07:43	75-30.06	165-13.01	583	-0.010	26.530	10027156
124	X124	2010/10/04	08:41	75-30.00	166-00.00	536	-0.066	26.658	10027155
125	X125	2010/10/04	16:54	76-12.01	166-17.46	360	-0.452	26.998	10027157
126	X126	2010/10/04	18:26	76-24.00	167-11.07	621	-0.997	26.135	10027215
127	X127	2010/10/05	08:22	76-06.07	164-22.45	944	-0.094	27.183	10027216
128	X128	2010/10/05	19:27	75-00.10	163-50.00	1144	-0.182	26.339	10027217
129	X129	2010/10/06	10:56	74-45.08	168-33.00	179	0.090	29.210	10027220
130	X130	2010/10/06	13:13	74-20.73	167-05.88	298	-0.234	27.492	10027218
131	X131	2010/10/06	17:57	73-58.60	164-12.01	231	0.174	26.519	10027219
132	X132	2010/10/07	02:17	73-23.02	163-14.85	79	0.374	29.541	10027223
133	X133	2010/10/07	07:04	73-11.51	162-53.05	122	0.549	29.035	10027222
134	X134	2010/10/07	21:31	73-45.95	158-13.61	3367	0.003	25.961	09022852
135	X135	2010/10/07	22:49	73-44.72	157-27.22	3651	-0.046	26.020	09022849
136	X136	2010/10/08	02:27	73-37.34	157-00.68	3320	-0.074	25.630	09022858
137	X137	2010/10/08	03:20	73-31.52	157-20.00	2994	0.006	25.649	09022856
138	X138	2010/10/08	04:08	73-35.35	157-39.08	3165	0.419	25.744	09022854
139	X139	2010/10/08	04:54	73-39.24	157-57.99	2127	-0.120	26.093	09022859
140	X140	2010/10/08	08:37	73-37.25	157-48.48	3254	-0.285	25.867	09022855
141	X141	2010/10/08	09:42	73-43.04	158-16.97	3246	-0.033	26.003	09022850
142	X142	2010/10/08	15:13	73-51.69	159-00.81	3235	0.211	26.153	09022857
143	X143	2010/10/08	18:15	73-56.01	159-22.36	2865	0.081	26.152	09022853
144	X144	2010/10/08	18:55	73-59.16	159-37.18	1198	-0.116	26.091	09022871
145	X145	2010/10/08	19:31	74-02.26	159-51.98	888	0.282	26.003	09022870
146	X146	2010/10/08	20:18	74-05.97	160-09.76	893	-0.233	25.650	10027224
147	X147	2010/10/08	21:04	74-04.82	159-37.89	720	0.032	25.827	10027221
148	X148	2010/10/08	21:48	74-03.91	159-06.02	2738	-0.229	25.994	10027225
149	X149	2010/10/08	22:31	74-02.85	158-34.01	3596	-0.017	26.495	10037444
150	X150	2010/10/08	23:14	74-02.23	158-02.03	3745	-0.170	25.980	10027226
151	X151	2010/10/09	06:15	74-04.09	157-09.00	3858	-0.085	26.178	09022869
152	X152	2010/10/09	07:41	73-57.50	157-52.65	3751	-0.394	26.325	09022869
153	X153	2010/10/09	11:21	73-51.50	158-32.00	3432	-0.268	26.152	09064456
154	X154	2010/10/09	12:59	73-47.66	159-01.54	3141	-0.073	26.193	09022866
155	X155	2010/10/09	13:31	73-45.12	159-15.02	2941	-0.127	26.058	09064452
156	X156	2010/10/09	16:23	73-40.75	159-44.97	2545	-0.602	25.786	09064454
157	X157	2010/10/09	20:30	74-01.66	159-51.10	942	-0.197	26.141	09064455
158	X158	2010/10/09	21:19	74-08.50	160-18.79	665	-0.248	25.960	09064453
159	X159	2010/10/10	01:32	74-17.40	161-50.00	1407	-0.212	25.856	09064459
160	X160	2010/10/10	03:10	74-23.71	163-10.42	1040	-0.102	26.083	09064458

Table3.3-1 Continued

161	X161	2010/10/10	14:00	74-58.95	161-59.89	1968	-0.900	26.078	09022867
162	X162	2010/10/10	17:13	74-30.14	161-59.75	1636	-0.536	25.959	09022865
163	X163	2010/10/10	23:26	73-30.03	161-59.39	200	-0.352	26.546	09022860
164	X164	2010/10/11	05:30	72-29.31	161-59.89	35	1.236	31.118	09022863
165	X165	2010/10/11	08:29	71-59.71	162-00.09	25	1.488	31.208	09022864
166	X166	2010/10/11	11:23	71-30.00	162-00.43	40	1.024	29.831	09022868
167	X167	2010/10/11	18:22	70-44.43	163-23.01	37	0.107	31.620	09064460
168	X168	2010/10/11	22:57	70-24.67	165-17.03	37	3.048	31.549	09064463

Acronyms in Table XCTD observation log are as follows;

Depth: Water Depth [m]

SST: Sea Surface Temperature [deg-C] measured by Continuous Sea Surface Monitoring System

SSS: Sea Surface Salinity [PSU] measured by Continuous Sea Surface Monitoring System

(6) Data archive

These data obtained in this cruise will be submitted to the Data Integration and Analysis Group (DIAG) of JAMSTEC, and will be opened to the public via “R/V Mirai Data Web Page” in JAMSTEC home page.

3.4. Shipboard ADCP

(1) Personnel

Motoyo Itoh	JAMSTEC: Principal Investigator	
Kazuho Yoshida	Global Ocean Development Inc.: GODI	- Leg1 -
Norio Nagahama	GODI	- Leg2 -
Satoshi Okumura	GODI	- Leg2 -
Souichiro Sueyoshi	GODI	- Leg2 -
Asuka Doi	GODI	- Leg2 -
Wataru Tokunaga	MIRAI Crew	

(2) Objective

To obtain continuous measurement of the current profile along the ship's track.

(3) Methods

Upper ocean current measurements were made in MR10-05 cruise, using the hull-mounted Acoustic Doppler Current Profiler (ADCP) system. For most of its operation in the Arctic Ocean, bottom-tracking mode, interleaved bottom-ping with water-ping, was made to get the calibration data for evaluating transducer misalignment angle. The system consists of following components;

- i) R/V MIRAI has installed the Ocean Surveyor for vessel-mount (acoustic frequency 75 kHz; Teledyne RD Instruments). It has a phased-array transducer with single ceramic assembly and creates 4 acoustic beams electronically. We mounted the transducer head rotated to a ship-relative angle of 45 degrees azimuth from the keel
- ii) For heading source, we use ship's gyro compass (Tokimec, Japan), continuously providing heading to the ADCP system directory. Additionally, we have Inertial Navigation System (INS) which provide high-precision heading, attitude information, pitch and roll, are stored in ".N2R" data files with a time stamp.
- iii) DGPS system (Trimble SPS751 & StarFixXP) providing position fixes.
- iv) We used VmDas version 1.4.2 (TRD Instruments) for data acquisition.
- v) To synchronize time stamp of ping with GPS time, the clock of the logging computer is adjusted to GPS time every 1 minute
- vi) We have placed ethylene glycol into the fresh water to prevent freezing in the sea chest.
- vii) The sound speed at the transducer does affect the vertical bin mapping and vertical velocity measurement, is calculated from temperature, salinity (constant value; 35.0 psu) and depth (6.5 m; transducer depth) by equation in Medwin (1975).

Data was configured for 8-m intervals starting 23-m below the surface. Every ping

was recorded as raw ensemble data (.ENR). Also, 60 seconds and 300 seconds averaged data were recorded as short term average (.STA) and long term average (.LTA) data, respectively. Major parameters for the measurement (Direct Command) are shown in Table 3.4-1.

(4) Preliminary results

Fig. 3.4-1 shows vertical cross section plot of water current in the mooring area of Barrow Canyon.

(5) Data archive

These data obtained in this cruise will be submitted to the Data Integration and Analysis Group (DIAG) of JAMSTEC, and will be opened to the public via “R/V MIRAI Data Web Page” in JAMSTEC home page.

(6) Remarks

The following period, data was not available.
06:54UTC - 07:14UTC 12 Oct. 2010

Table 3.4-1 Major parameters

<i>Bottom-Track Commands</i>	
BP = 000	Pings per Ensemble (almost over 1000m depth) 25 Aug. 2010 12:20UTC – 29 Aug. 2010 21:25UTC 29 Aug. 2010 22:45UTC – 1 Sep. 2010 14:40UTC 14 Sep. 2010 12:12UTC – 14 Sep. 2010 20:40UTC 30 Sep. 2010 07:37UTC – 2 Oct. 2010 04:41UTC
BP = 001	Pings per Ensemble (almost less than 1000m depth) 24 Aug. 2010 07:00UTC – 25 Aug. 2010 12:20UTC 29 Aug. 2010 21:25UTC – 29 Aug. 2010 22:45UTC 1 Sep. 2010 14:40UTC – 1 Sep. 2010 17:49UTC 2 Sep. 2010 16:39UTC – 14 Sep. 2010 12:12UTC 14 Sep. 2010 20:40UTC – 30 Sep. 2010 07:37UTC 2 Oct. 2010 04:41UTC – 16 Oct. 2010 19:04UTC
<i>Environmental Sensor Commands</i>	
EA = +04500	Heading Alignment (1/100 deg)
EB = +00000	Heading Bias (1/100 deg)
ED = 00065	Transducer Depth (0 - 65535 dm)
EF = +001	Pitch/Roll Divisor/Multiplier (pos/neg) [1/99 - 99]

EH = 00000	Heading (1/100 deg)
ES = 35	Salinity (0-40 pp thousand)
EX = 00000	Coord Transform (Xform:Type; Tilts; 3Bm; Map)
EZ = 10200010	Sensor Source (C; D; H; P; R; S; T; U)
	C (1): Sound velocity calculates using ED, ES, ET (temp.)
	D (0): Manual ED
	H (2): External synchro
	P (0), R (0): Manual EP, ER (0 degree)
	S (0): Manual ES
	T (1): Internal transducer sensor
	U (0): Manual EU

Timing Commands

TE = 00:00:02.00	Time per Ensemble (hrs:min:sec.sec/100)
TP = 00:02.00	Time per Ping (min:sec.sec/100)

Water-Track Commands

WA = 255	False Target Threshold (Max) (0-255 count)
WB = 1	Mode 1 Bandwidth Control (0=Wid, 1=Med, 2=Nar)
WC = 120	Low Correlation Threshold (0-255)
WD = 111 100 000	Data Out (V; C; A; PG; St; Vsum; Vsum^2;#G;P0)
WE = 1000	Error Velocity Threshold (0-5000 mm/s)
WF = 0800	Blank After Transmit (cm)
WG = 001	Percent Good Minimum (0-100%)
WI = 0	Clip Data Past Bottom (0 = OFF, 1 = ON)
WJ = 1	Rcvr Gain Select (0 = Low, 1 = High)
WM = 1	Profiling Mode (1-8)
WN = 100	Number of depth cells (1-128)
WP = 00001	Pings per Ensemble (0-16384)
WS = 0800	Depth Cell Size (cm)
WT = 000	Transmit Length (cm) [0 = Bin Length]
WV = 0390	Mode 1 Ambiguity Velocity (cm/s radial)

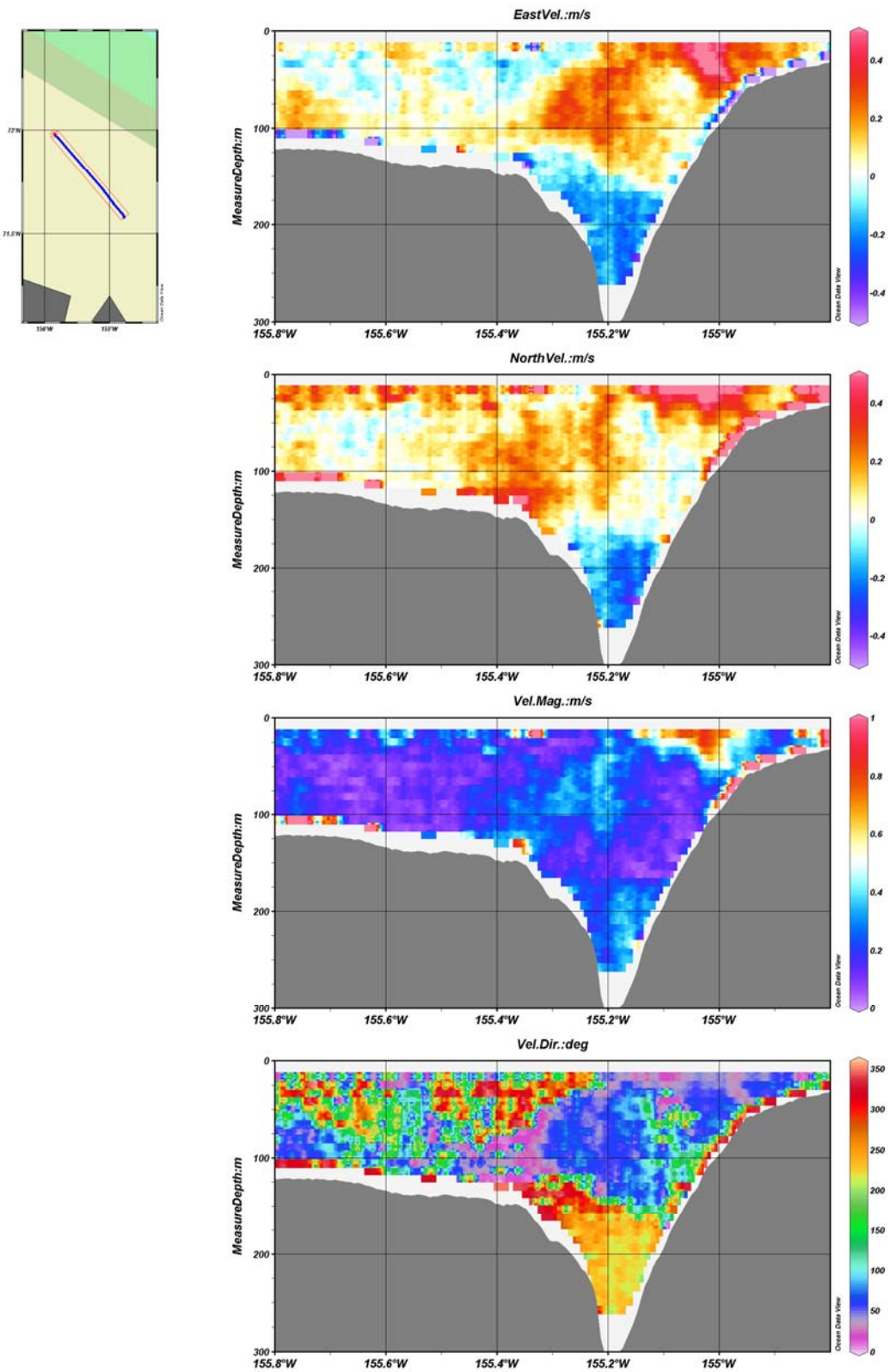

Fig 3.4-1 Cross section of water current in the Barrow Canyon on 30 Sep.

3.5. Micro structure observations

(1) Personnel

Motoyo Itoh (JAMSTEC): Principal Investigator

Yusuke Kawaguchi (JAMSTEC)

Shigeto Nishino (JAMSTEC)

Norio Nagahama (GODI): Operation leader

Satoshi Okumura (GODI): Technical staff

Soichiro Sueyoshi (GODI): Technical staff

Asuka Doi (GODI): Technical staff

(2) Objectives

To understand the Arctic Ocean circulation and mixing, turbulence-scale temperature, conductivity and shear were observed. Most of micro structure observations were performed at CTD stations.

(3) Parameters

According to the manufacture's nominal specifications, the range, accuracy and sample rate of parameters are as follows

Parameter	Type	Range	Accuracy	Sample Rate
$\partial u/\partial z$ (Primary)	Shear probe	0~10 /s	5%	512Hz
$T+\partial T/\partial z$	EPO-7 thermistor	-5~45°C	$\pm 0.01^\circ\text{C}$	512Hz
T	Platinum wire thermometer	-5~45°C	$\pm 0.01^\circ\text{C}$	64Hz
Conductivity	Inductive Cell	0~70mS	$\pm 0.01\text{mS}$	64Hz
Depth	Semiconductor strain gauge	0~1000m	$\pm 0.2\%$	64Hz
x- acceleration	Solid-state fixed mass	$\pm 2\text{G}$	$\pm 1\%$	256Hz
y- acceleration	Solid-state fixed mass	$\pm 2\text{G}$	$\pm 1\%$	256Hz
z- acceleration	Solid-state fixed mass	$\pm 2\text{G}$	$\pm 1\%$	64Hz
Chlorophyll	Fluorescence	0~100 $\mu\text{g/Lm}$	0.5 $\mu\text{g/L}$ or $\pm 1\%$	256Hz
Turbidity	Backscatter	0~100ppm	1ppm or $\pm 2\%$	256Hz
$\partial u/\partial z$ (Secondary)	$\partial u/\partial z$ Shear	0~10 /s	5%	512Hz

(4) Instruments

Turbulence Ocean Microstructure Acquisition Profiles (TurboMAP-L, build by Alec Electronics Co Ltd.) was used to measure turbulence-scale temperature, conductivity, and shear. Turbo Map is a quasi-free-falling instrument that measures turbulence parameter ($\partial u/\partial z$ and $\partial T/\partial z$), bio-optical parameters (in vivo fluorescence and back scatter) and hydrographic parameter (C, T, D).

(5) Station List

No.	Date [YYYY/MM/DD]	Longitude [degN]	Latitude [degW]	Logging Time		Depth [m]	Observation Depth[m]	Wire Length [m]
				Start	Stop			
01	2010/09/08	74-15.76	162-35.07	14:48	15:08	1107	900	1100
02	2010/09/08	74-00.25	163-13.85	18:29	18:41	300	268	300
03	2010/09/10	71-57.53	150-14.36	15:22	15:53	3002	1036	1100
04	2010/09/11	71-36.09	151-39.54	00:21	00:52	998	950	1000
05	2010/09/11	71-22.01	152-06.99	03:31	03:35	68	54.5	70
06	2010/09/12	71-47.85	155-19.99	18:12	18:21	180	138	170
07	2010/09/12	71-47.85	155-19.99	18:23	18:29	180	157	200
08	2010/09/12	71-40.80	154-58.47	19:33	19:42	109	84	105
09	2010/09/12	71-45.27	154-58.73	23:01	23:11	223	181	250
10	2010/09/13	71-35.06	155-59.34	02:20	02:27	196	165	260
11	2010/09/13	71-35.12	155-58.17	02:31	02:39	201	181	300
12	2010/09/13	71-20.36	157-58.33	06:45	06:50	120	111	140
13	2010/09/13	71-06.56	159-17.57	09:57	10:06	85	78	100
14	2010/09/16	77-34.90	167-29.06	22:20	22:36	432	425	500
15	2010/09/22	76-15.47	173-59.47	01:00	01:34	2225	1062	1100
16	2010/09/22	77-04.99	170-00.03	18:24	18:55	2221	1091	1100
17	2010/09/23	77-12.56	167-54.14	03:46	04:02	530	521	550
18	2010/09/27	75-39.61	156-18.38	00:54	01:27	1434	1084	1100
19	2010/09/27	75-44.79	157-06.30	04:26	04:55	965	966	1050
20	2010/09/30	72-52.93	158-48.62	21:40	21:55	351	326	380
21	2010/10/02	74-34.48	157-55.68	02:59	03:20	1309	598	1100
22	2010/10/08	73-35.39	157-39.17	07:15	07:27	3170	1066	1100
23	2010/10/08	73-44.20	158-27.60	12:26	12:48	3245	759	1100
24	2010/10/08	73-54.41	159-13.30	17:09	17:36	3195	840	1100
25	2010/10/09	74-00.05	157-30.38	04:57	05:18	3850	582	730
26	2010/10/09	73-53.85	158-15.42	10:15	10:36	3577	530	780
27	2010/10/09	73-47.45	159-00.39	12:14	12:34	3138	527	700
28	2010/10/09	73-43.09	159-31.25	15:26	15:43	2748	520	750
29	2010/10/09	73-57.99	159-31.57	19:28	19:45	2054	522	950
30	2010/10/12	69-59.98	167-59.99	03:44	03:48	46	45	50

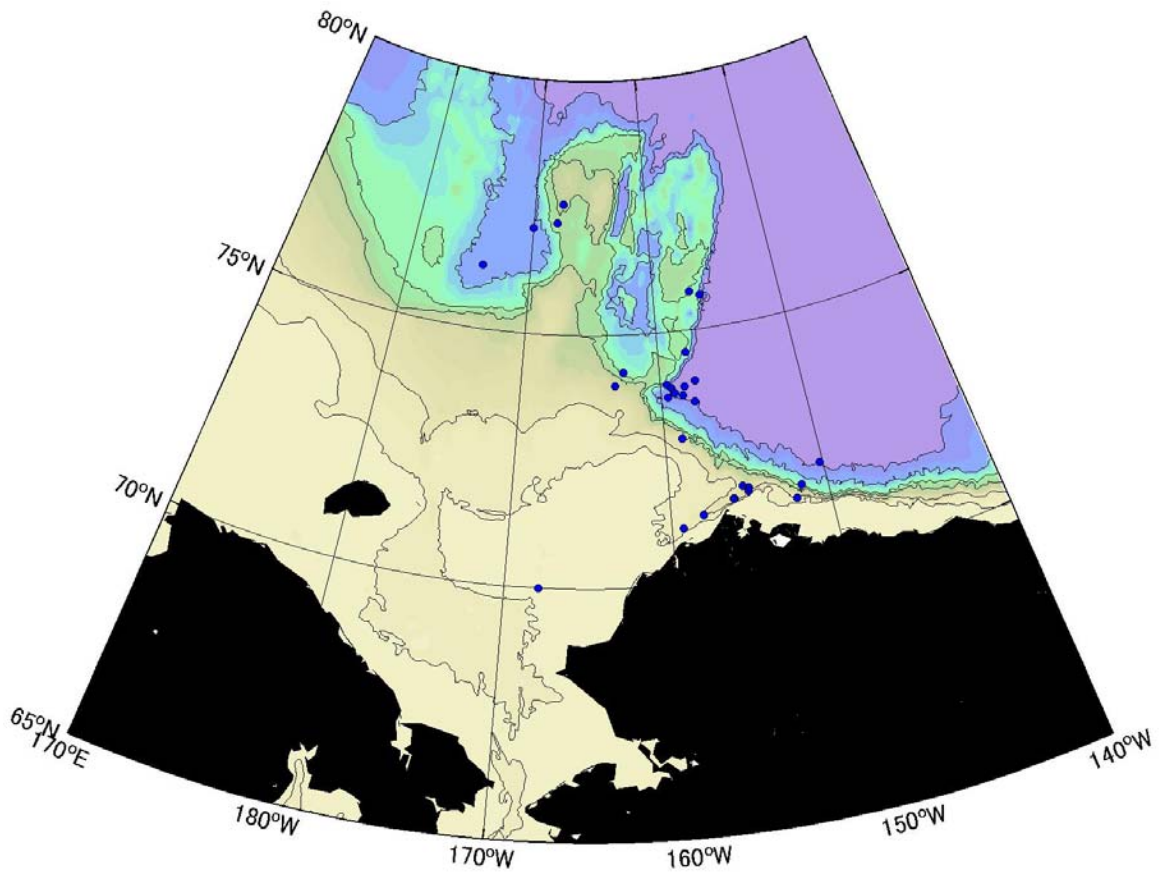

Figure 3.5-1 Blue dots indicate the Turbo Map station.

(5) Data archives

All raw and processed data files were copied onto HD provided by Data Management Office (DMO); JAMSTEC will be opened to public via “R/V MIRAI Data Web Page” in the JAMSTEC home page.

3.6. Mooring Deployment

We have deployed three moorings in the Barrow Canyon (BCE-10, BCC-10, BCW-10) and one mooring in the Chukchi Abyssal Plain (CAP-10). Two sediment trap moorings (CAP-10t and NAP-10t) were also deployed during MR10-05. Detail of the sediment trap moorings is described in section 4-15 (PI: Naomi Harada, JAMSTEC).

(1) Personnel

Motoyo Itoh (JAMSTEC): Principal Investigator

Takashi Kikuchi (JAMSTEC)

Shigeto Nishino (JAMSTEC)

Tomohide Noguchi (MWJ): Operation leader

Hirokatsu Uno (MWJ): Technical staff

Satoshi Ozawa (MWJ): Technical staff

Shinsuke Toyoda (MWJ): Technical staff

Tatsuya Tanaka (MWJ): Technical staff

(2) Objectives

The purpose of mooring measurements in the Barrow Canyon (BCE-10, BCC-10, BCW-10) is to monitor the variations of volume, heat and fresh water flux of Pacific Water through the Barrow Canyon. The purpose of mooring measurements in the Chukchi Abyssal Plain (CAP-10) is to monitor the variations of Pacific Water and East Siberian Shelf Water inflow. Components of this mooring are depicted in Figures 3.6-1.

(3) Parameters

- Ocean current velocities
- Echo intensity, bottom tracking range and velocities for sea ice measurements
- Pressure, Temperature and Conductivity

(4) Instruments

1) CTD or CT sensors

SBE37-SM (Sea Bird Electronics Inc.)

SBE16 (Sea Bird Electronics Inc.)

2) Current meters

Workhorse ADCP 300 kHz (Teledyne RD Instruments, Inc.)

RCM-7 (AANDERAA DATA INSTRUMENTS)

RCM-8 (AANDERAA DATA INSTRUMENTS)

RCM-9 (AANDERAA DATA INSTRUMENTS)

S4 current meter (InterOcean systems, Inc.)

3) Acoustic Releaser

Model- L (Nichiyu giken kogyo co., LTD)

Model-Lti (Nichiyu giken kogyo co., LTD)

8202 (ORE offshore)

8242XS (ORE offshore)

4) Transponder
XT-6000 (BENTHOS, Inc.)

(5) List of deployed mooring

Deployment mooring

Mooring ID	Deployment Date	Latitude	Longitude
BCC-10	2010/09/11	71-43.5496'N	155-10.8963'W
BCE-10	2010/09/11	71-40.3526'N	154-59.7418'W
BCW-10	2010/09/29	71-47.8495'N	155-20.3220'W
CAP-10	2010/09/17	76-00.1932'N	175-15.3937'W
CAP-10t	2010/09/17	75-59.98'N	175-00.28'W
NAP-10t	2010/10/3	75-00.01' N	162-00.17' W

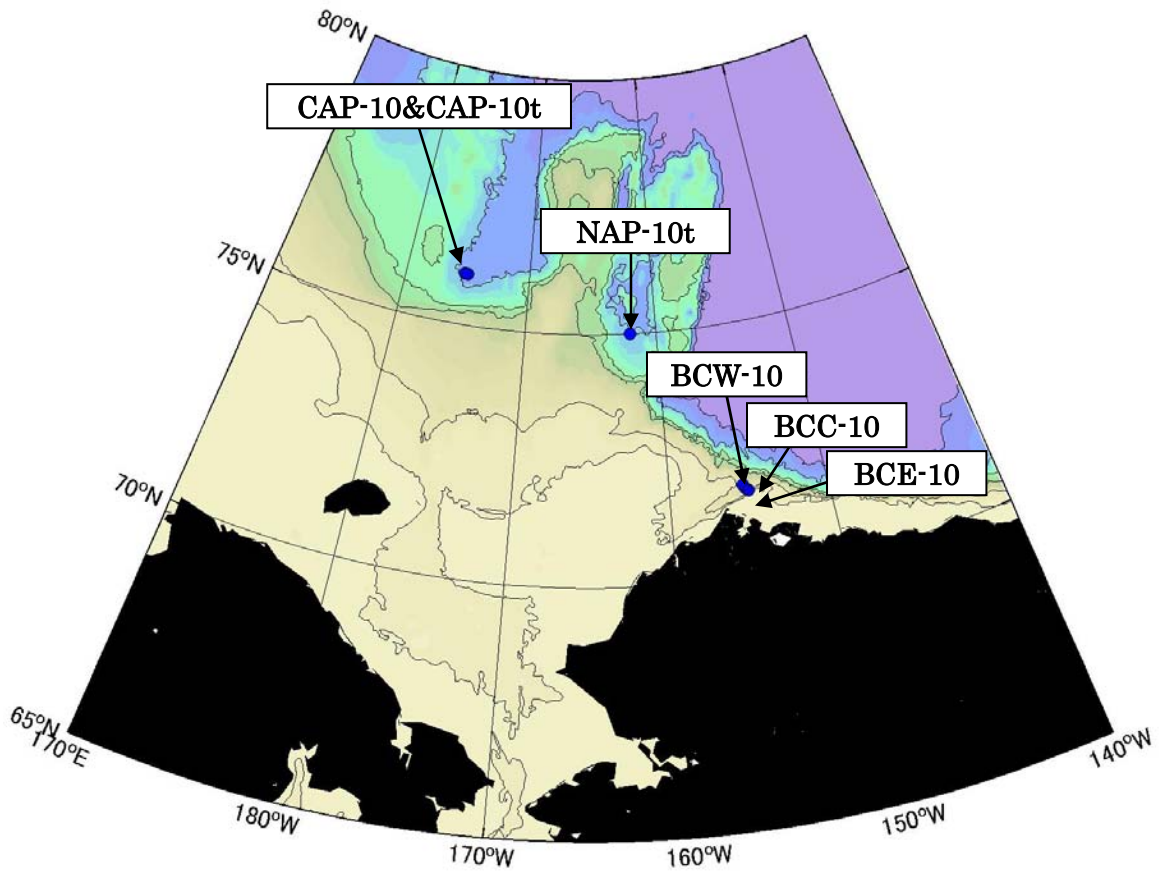
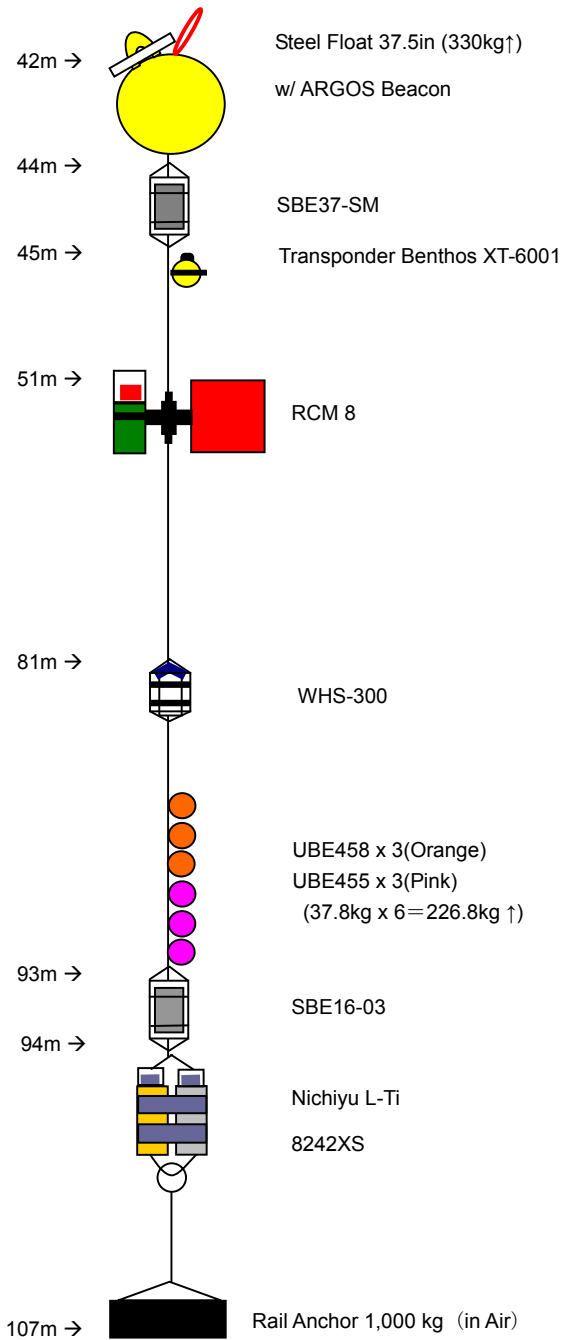

Figure 3.6-1 Blue dots indicate the mooring station.

BCE – 10



Position: 71° 40.3526' N
 (@Sinker drop) 154° 59.7418' W

Depth: 107m

Figure 3.6-2 Diagram of BCE-10.

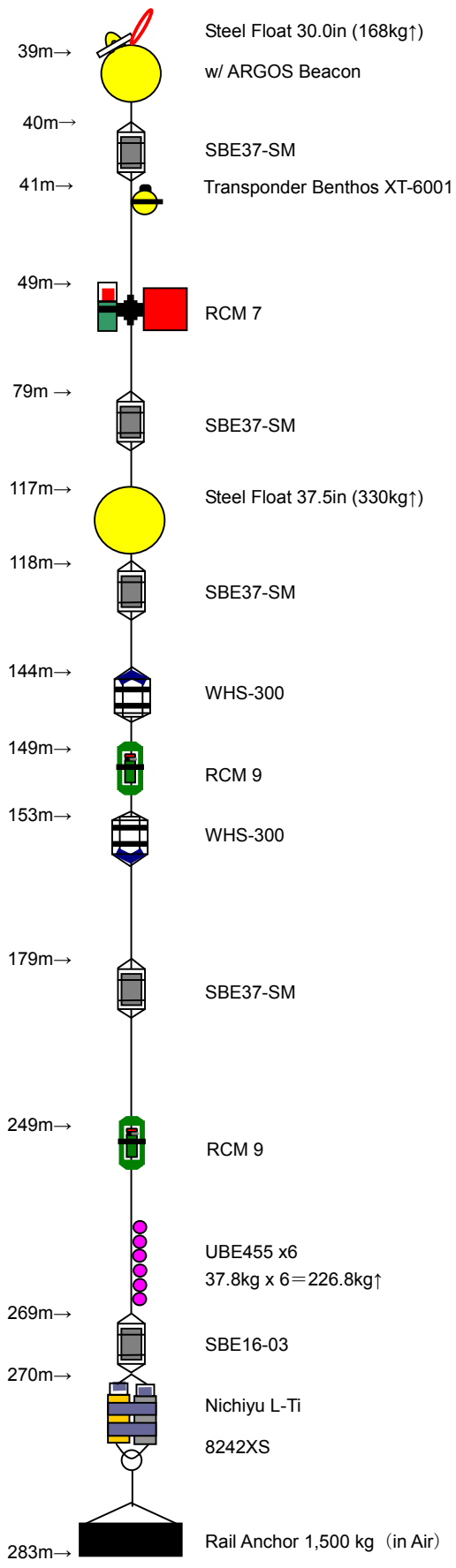

BCC – 10

Position: 71° 43.5496' N
 (@Sinker drop) 155° 10.8963' W

Depth: 283m

Figure 3.6-3 Diagram of BCC-10.

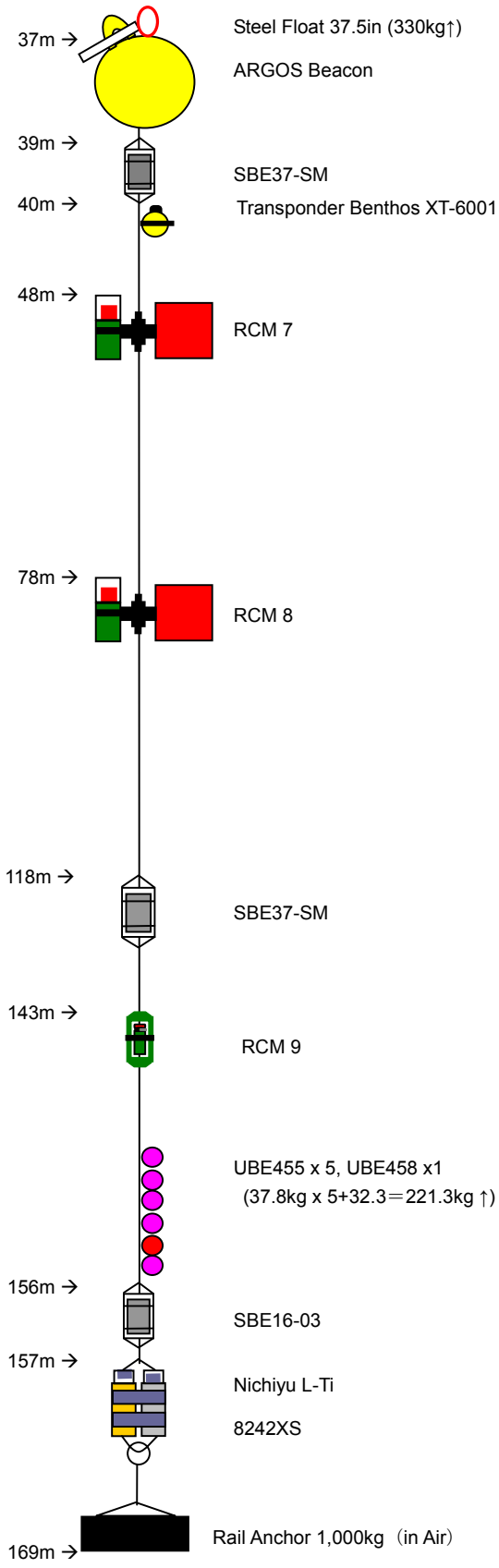

BCW – 10

Re-Deployment

Position: 71° 47.8495'N
(@Sinker drop) 155° 20.3220'W

Depth: 170m

Figure 3.6-4 Diagram of BCW-10.

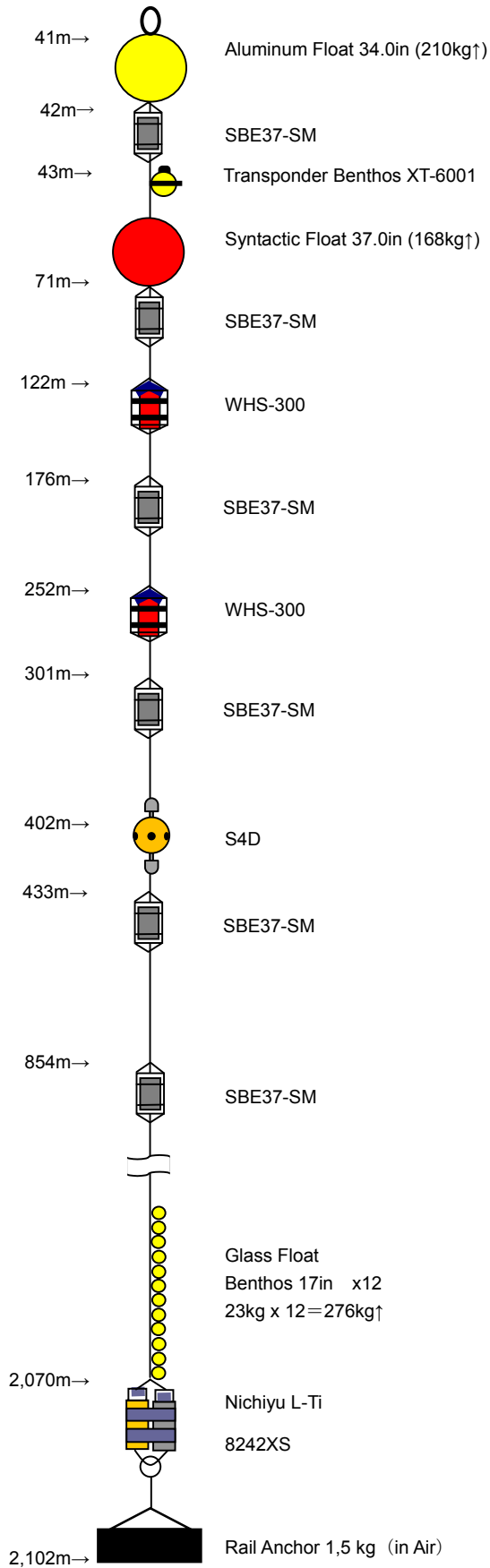

CAP – 10

Position: 76° 00.1932' N
 (@Transponder) 175° 15.3937' W

Depth: 2,102m

Figure 3.6-5 Diagram of CAP-10.

3.7. ADCP and Plankton Net tow

(1) Personnel

Motoyo Itoh (JAMSTEC): Principal Investigator

Jonaotaro Onodera (JAMSTEC)

Tomohide Noguchi (MWJ): Technical staff

Hirokatsu Uno (MWJ): Technical staff

(2) Objectives

To evaluate biomass of zooplankton, acoustic echo intensity measurement and vertical plankton net tow were conducted.

(3) Parameters

Echo intensity is measured by Workhorse ADCP 300 kHz (Teledyne RD Instruments, Inc.) at 150m (or bottom -5m to surface if water depth is shallower than 150m). Plankton sample were collected by Twin NORPAC net (mesh is 0.1mm). The twin NORPAC net is towed from 150 m (or bottom -5m) to surface. Collected zooplankton samples from each net were fixed with formalin or filtered. The filters were frozen during the cruise.

(4) Station List

No.	CTD station	Time (LT)	Latitude	Longitude	Depth (m)
1	12	2010/09/05 16:17	70 00.32 N	167 59.46 W	40
2	18	2010/09/07 10:16	74 36.10 N	170 56.01 W	150
3	23	2010/09/10 13:08	71 39.65 N	151 14.18 W	150
4	26	2010/09/10 20:03	71 21.98 N	152 06.99 W	60
5	28	2010/09/12 14:37	71 44.88 N	155 01.44 W	150
6	35	2010/09/16 07:02	78 15.52 N	169 58.98 W	150
7	42	2010/09/18 15:30	75 24.26 N	178 12.78 E	150
8	44	2010/09/18 20:49	74 59.87 N	177 43.59 E	150
9	48	2010/09/19 10:04	74 59.94 N	176 01.82 W	150
10	58	2010/09/22 02:04	76 40.49 N	171 59.48 W	150
11	65	2010/09/22 23:28	77 15.91 N	166 20.21 W	150
12	70	2010/09/23 21:15	78 52.30 N	165 00.62 W	150
13	72	2010/09/24 17:43	77 44.96 N	162 01.59 W	150
14	77	2010/09/25 12:35	76 37.02 N	157 03.74 W	150
15	86	2010/09/28 07:17	70 59.92 N	162 01.59 W	40
16	92	2010/09/28 19:40	71 24.70 N	157 28.27 W	115
17	106	2010/09/30 00:32	72 10.98 N	157 11.04 W	110
18	107	2010/09/30 06:21	72 29.99 N	159 59.70 W	38
19	111	2010/09/30 12:27	72 53.03 N	158 48.56 W	150
20	116	2010/10/01 11:18	74 03.64 N	155 17.86 W	150
21	121	2010/10/02 09:52	74 22.53 N	165 14.76 W	150
22	125	2010/10/02 22:12	73 58.86 N	167 36.56 W	155
23	126	2010/10/03 17:08	75 00.24 N	161 59.61 W	150

24	128	2010/10/04 07:19	76	00.06	N	165	29.68	W	150
25	139	2010/10/05 19:07	75	00.41	N	167	14.63	W	150
26	143	2010/10/06 16:22	73	42.79	N	162	45.85	W	150
27	144	2010/10/06 21:26	73	03.36	N	163	45.19	W	85
28	154	2010/10/08 19:28	74	00.99	N	157	30.19	W	150
29	158	2010/10/09 15:30	74	11.44	N	160	29.76	W	150
30	165	2010/10/11 13:51	70	29.73	N	164	45.23	W	35
31	170	2010/10/12 12:53	68	00.05	N	168	49.92	W	50
32	175	2010/10/13 11:41	65	45.71	N	168	29.73	W	50

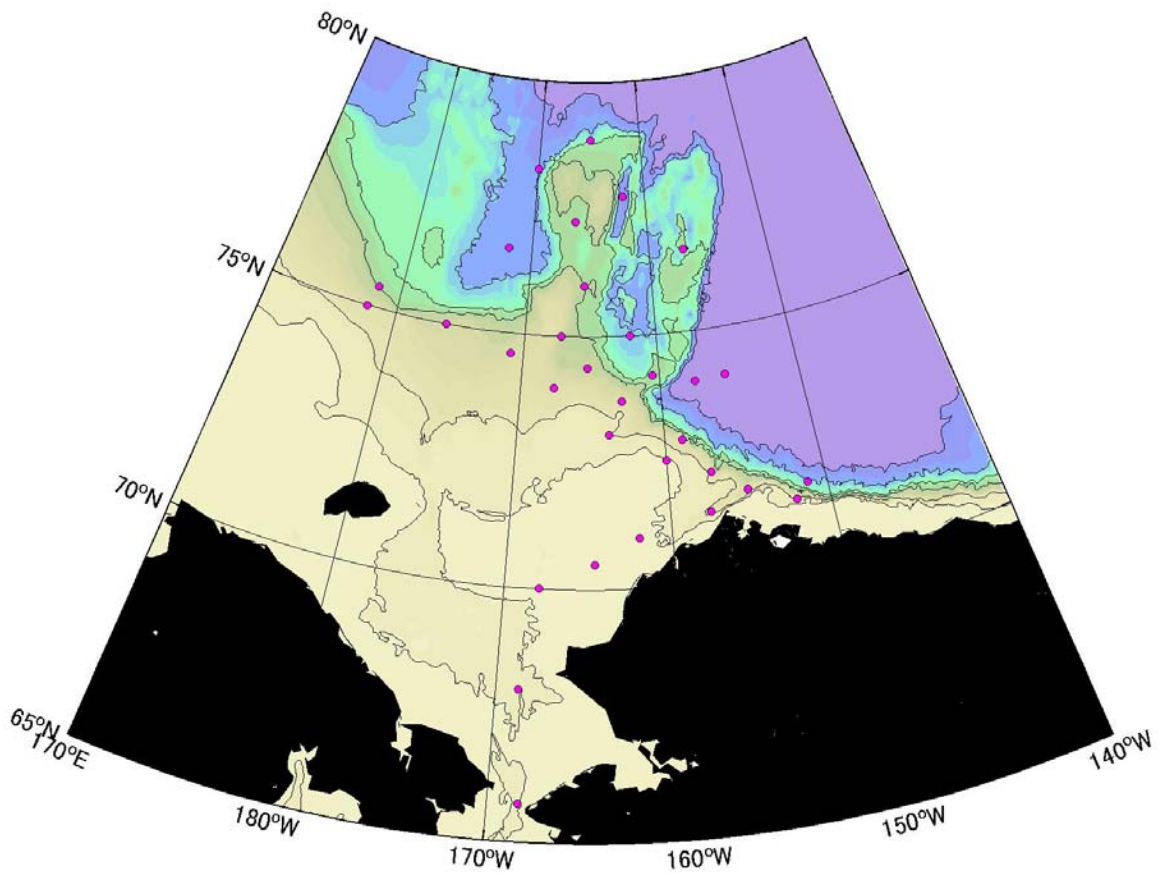

Figure 3.7-1 Pink dots indicate the plankton net and ADCP station.

(5) Data archives

All raw and processed data files were copied onto HD provided by Data Management Office (DMO); JAMSTEC will be opened to public via “R/V MIRAI Data Web Page” in the JAMSTEC home page.

4. Chemical and Biological Observations

4.1. Dissolved Oxygen

(1) Personnel

Shigeto NISHINO (JAMSTEC): Principal Investigator

Motoyo ITOH (JAMSTEC)

Misato KUWAHARA (MWJ): Operation Leader

Hironori SATO (MWJ)

Fuyuki SHIBATA (MWJ)

(2) Objectives

Determination of dissolved oxygen in seawater by Winkler titration.

(3) Parameter

Dissolved Oxygen

(4) Instruments and Methods

Following procedure is based on an analytical method, entitled by “Determination of dissolved oxygen in sea water by Winkler titration”, in the WHP Operations and Methods (Dickson, 1996).

a. Instruments

Burette for sodium thiosulfate and potassium iodate;

APB-510 manufactured by Kyoto Electronic Co. Ltd. / 10 cm³ of titration vessel

Detector;

Automatic photometric titrator (DOT-01) manufactured by Kimoto Electronic Co. Ltd.

Software;

DOT controller Ver.2.2.1

b. Reagents

Pickling Reagent I: Manganese chloride solution (3 mol dm⁻³)

Pickling Reagent II:

Sodium hydroxide (8 mol dm⁻³) / sodium iodide solution (4 mol dm⁻³)

Sulfuric acid solution (5 mol dm⁻³)

Sodium thiosulfate (0.025 mol dm⁻³)

Potassium iodide ($0.001667 \text{ mol dm}^{-3}$)

CSK standard of potassium iodide:

Lot TSK3592, Wako Pure Chemical Industries Ltd., 0.0100N

c. Sampling

Seawater samples were collected with Niskin bottle attached to the CTD-system and surface bucket sampler. Seawater for oxygen measurement was transferred from sampler to a volume calibrated flask (ca. 100 cm^3). Three times volume of the flask of seawater was overflowed. Temperature was measured by digital thermometer during the overflowing. Then two reagent solutions (Reagent I and II) of 0.5 cm^3 each were added immediately into the sample flask and the stopper was inserted carefully into the flask. The sample flask was then shaken vigorously to mix the contents and to disperse the precipitate finely throughout. After the precipitate has settled at least halfway down the flask, the flask was shaken again vigorously to disperse the precipitate. The sample flasks containing pickled samples were stored in a laboratory until they were titrated.

d. Sample measurement

At least two hours after the re-shaking, the pickled samples were measured on board. 1 cm^3 sulfuric acid solution and a magnetic stirrer bar were added into the sample flask and stirring began. Samples were titrated by sodium thiosulfate solution whose morality was determined by potassium iodate solution. Temperature of sodium thiosulfate during titration was recorded by a digital thermometer. During this cruise, we measured dissolved oxygen concentration using 2 sets of the titration apparatus. Dissolved oxygen concentration ($\mu\text{mol kg}^{-1}$) was calculated by sample temperature during seawater sampling, salinity of the CTD sensor, flask volume, and titrated volume of sodium thiosulfate solution without the blank. When we measured high or low concentration samples, titration procedure was adjusted manually.

e. Standardization and determination of the blank

Concentration of sodium thiosulfate titrant was determined by potassium iodate solution. Pure potassium iodate was dried in an oven at $130 \text{ }^\circ\text{C}$. 1.7835 g potassium iodate weighed out accurately was dissolved in deionized water and diluted to final volume of 5 dm^3 in a calibrated volumetric flask ($0.001667 \text{ mol dm}^{-3}$). 10 cm^3 of the standard potassium iodate solution was added to a flask using a volume-calibrated dispenser. Then 90 cm^3 of deionized water, 1 cm^3 of sulfuric acid solution, and 0.5 cm^3 of

pickling reagent solution II and I were added into the flask in order. Amount of titrated volume of sodium thiosulfate (usually 5 times measurements average) gave the morality of sodium thiosulfate titrant.

The oxygen in the pickling reagents I (0.5 cm³) and II (0.5 cm³) was assumed to be 3.8 x 10⁻⁸ mol (Murray *et al.*, 1968). The blank due to other than oxygen was determined as follows. 1 and 2 cm³ of the standard potassium iodate solution were added to two flasks respectively using a calibrated dispenser. Then 100 cm³ of deionized water, 1 cm³ of sulfuric acid solution, and 0.5 cm³ of pickling reagent solution II and I each were added into the flask in order. The blank was determined by difference between the first (1 cm³ of KIO₃) titrated volume of the sodium thiosulfate and the second (2 cm³ of KIO₃) one. The results of 3 times blank determinations were averaged.

Table 4.1-1 shows results of the standardization and the blank determination during this cruise.

Table 4.1-1. Results of the standardization and the blank determinations during this cruise

Date	KIO ₃ ID	Na ₂ S ₂ O ₃	DOT-01(No.1)		DOT-01(No.2)		Stations
			E.P.	Blank	E.P.	Blank	
2010/9/3	20091215-04-01	20091207-07-1	3.960	-0.001	3.962	0.001	001,002,003,004,006, 007,008,010
2010/9/3	CSK	20091207-07-1	3.961	-0.001	3.963	0.001	
2010/9/3	20091215-03-11	20091207-07-1	3.961	-0.001			
2010/9/7	20091215-04-02	20091207-07-1	3.962	0.001	3.960	0.001	013,014,015,016,017, 018
2010/9/8	20091215-04-03	20091207-07-1	3.960	-0.001	3.958	0.000	
2010/9/9	20091215-04-03	20091207-07-2	3.960	0.001	3.958	-0.001	019,020,021,022,023, 024,025,026,028,030, 031,032
2010/9/14	20091215-04-04	20091207-07-2	3.957	0.000	3.955	0.001	
2010/9/14	20091215-04-04	20091207-08	3.960	0.001	3.958	-0.001	034,035,036,037,038, 039
2010/9/18	20091215-04-05	20091207-08	3.961	0.002	3.959	-0.001	040,041,042,043,044, 046,047,048,049,050, 051,052
2010/9/21	20091215-04-06	20091207-08	3.958	0.001	3.957	0.000	

2010/9/21	20091216-06-01	20091207-08	3.959	0.000	3.960	-0.001	053,054,056
2010/9/22	20091216-06-02	20091207-08	3.962	0.000	3.960	0.000	
2010/9/22	20091216-06-02	20091207-08	3.961	-0.001	3.962	0.000	058,060,062,063,065, 068,070,071,072,075, 077
2010/9/26	20091216-06-03	20091207-09	3.959	-0.001	3.961	-0.002	079,081,082,083,086, 087,088,092,096
2010/9/29	20091216-06-04	20091207-09	3.960	-0.001	3.958	-0.001	
2010/9/29	20091216-06-04	20091207-10	3.962	-0.001	3.962	-0.001	105,106,107,109,111, 113,115,116,117,119
2010/10/2	20091216-06-05	20091207-10	3.960	0.000	3.959	0.000	121,123,125,126,128, 129,131,133,135,137, 139
2010/10/6	20091216-06-06	20091207-10	3.966	0.000	3.966	0.001	
2010/10/6	20091216-06-06	20091207-11	3.961	-0.001	3.962	-0.002	140,142,143,144,146, 148,149,150,151,153
2010/10/9	20091216-06-07	20091207-11	3.960	-0.001	3.959	-0.001	154,155,156,157,158, 159,160,161,162,163
2010/10/11	20091216-06-08	20091207-11	3.961	-0.001	3.961	-0.002	
2010/10/11	20091216-06-08	20091207-12	3.961	0.000	3.962	-0.002	164,165,166,168,170, 172,174,175
2010/10/14	20091216-06-09	20091207-12	3.961	0.000	3.958	-0.001	
2010/10/14	20100630-01-01	20091207-12	3.969	0.000	3.966	-0.001	
2010/10/14	CSK	20091207-12	3.963	0.000	3.961	-0.001	

f. Repeatability of sample measurement

Replicate samples were taken at every CTD casts. Total amount of the replicate sample pairs of good measurement was 324. The standard deviation of the replicate measurement was 0.29 $\mu\text{mol kg}^{-1}$ that was calculated by a procedure in Guide to best practices for ocean CO₂ measurements Chapter4 SOP23 Ver.3.0 (2007). Results of replicate samples were shown in Table 4.1-2 and this diagram shown in Fig. 4.1-1 and -2.

Table 4.1-2. Results of the replicate sample measurements

Layer	Number of replicate sample pairs	Oxygen concentration ($\mu\text{mol kg}^{-1}$) Standard Deviation.
1000m \geq	271	0.31
>1000m	53	0.09
All	324	0.29

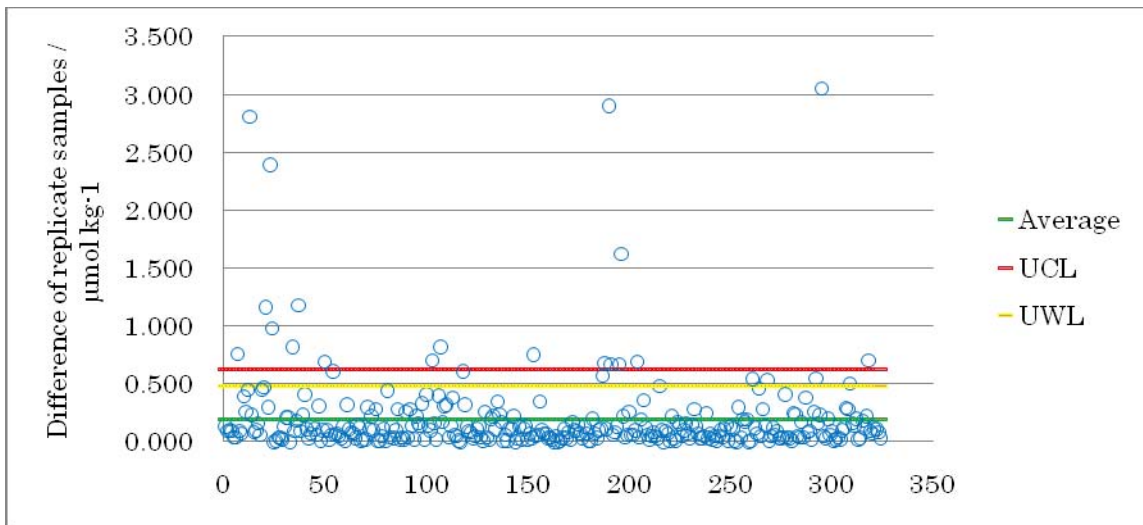

Fig. 4.1-1. Differences of replicate samples against sequence number.

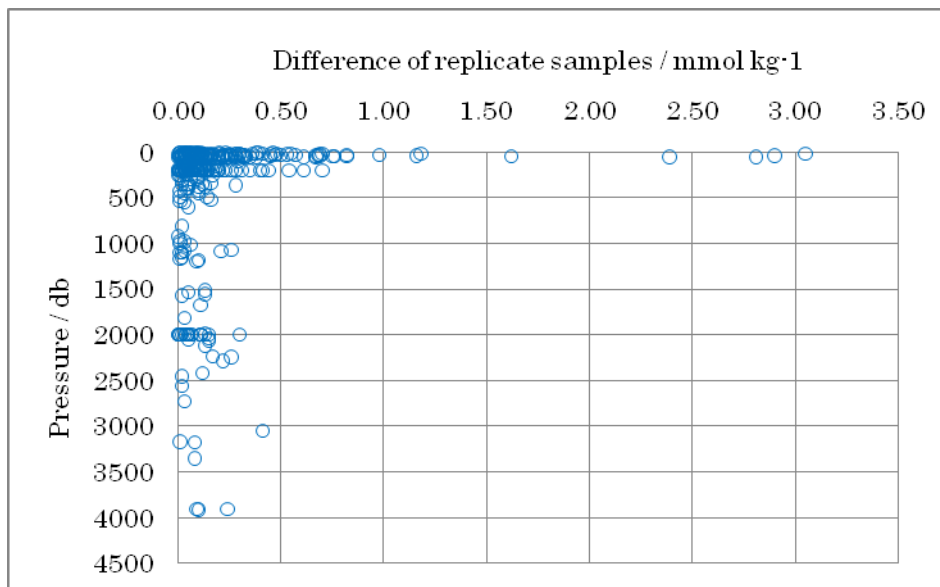

Fig. 4.1-2. Differences of replicate samples against pressure.

(5) Data archive

These data obtained in this cruise will be submitted to the Data Management Office (DMO) of JAMSTEC, and will be opened to the public via “R/V Mirai Data Web Page” in JAMSTEC home page.

(6) References

Dickson, A.G., Determination of dissolved oxygen in sea water by Winkler titration. (1996)

Dickson, A.G., Sabine, C.L. and Christian, J.R. (Eds.), Guide to best practices for ocean CO₂ measurements. (2007)

Culberson, C.H., WHP Operations and Methods July-1991 “Dissolved Oxygen”, (1991)
Japan Meteorological Agency, Oceanographic research guidelines (Part 1). (1999)

KIMOTO electric CO. LTD., Automatic photometric titrator DOT-01 Instruction manual

4.2. Nutrients

(1) Personnel

Michio AOYAMA (MRI/JMA) :Principal investigator

Shigeto Nishino (JAMSTEC)

Kimiko NISHIJIMA (MWJ) :Operation leader

Junji MATSUSHITA (MWJ)

Ai TAKANO (MWJ)

Kenichiro SATO (MWJ)

(2) Objectives

The objectives of nutrients analyses during the R/V Mirai MR10-05 cruise in the Arctic Ocean are as follows:

- Describe the present status of nutrients concentration with excellent comparability.

(3) Parameters

The determinants are nitrate, nitrite, phosphate, silicate and ammonia in the Arctic Ocean.

(4) Summary of nutrients analysis

We made 85 QuAAtro runs for the samples at 119 stations in MR10-05. The total amount of layers of the seawater sample reached up to 2012 for MR10-05. We made duplicate measurement at all layers. The station locations for nutrients measurement is shown in Figure 4.2-1

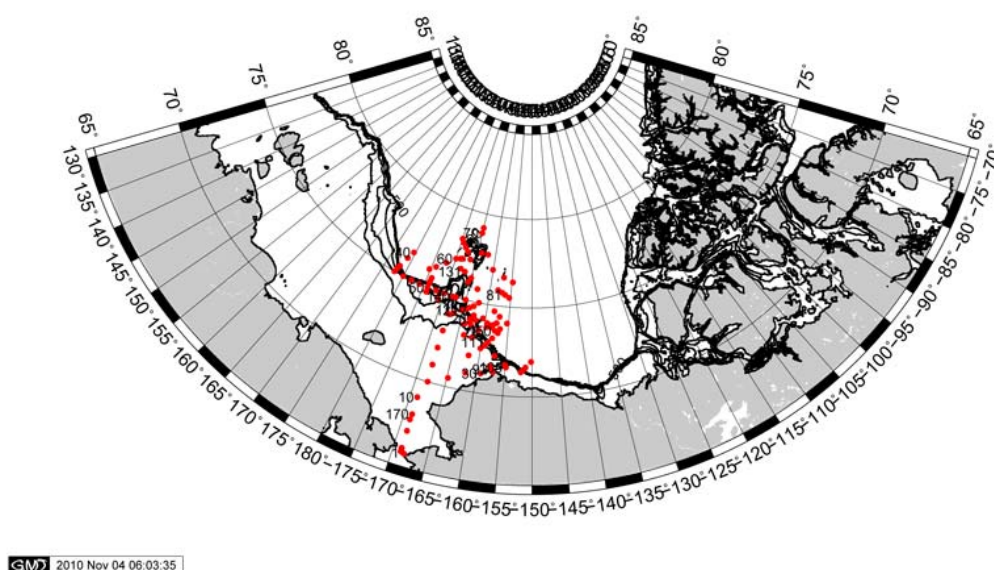

Figure 4.2-1 Sampling positions of nutrients sample.

(5) Instrument and Method

a. Protocol of seawater sampling and pasteurization for RMNS

To stop the biological is a main issue to keep the nutrient concentrations in seawater sampled. To ensure this onboard, we need to keep seawater as a condition “85 deg. C, 5 hours in cap tighten”, pasteurization, for deep seawater samples. Therefore, we carry out as follow;

Rinse out drops at the outside of NISKIN bottles with fresh waters before start drawing the deep seawater. Because drops of surface seawater will work as bad boy, it enhances biological activity of the deep seawater. Rinse cubitainers and tubes with seawater from NISKIN bottles. Fill the cubitainer with seawater from two NISKIN bottles using tubes. During the seawater is flowing out, you wash the cap with seawater and cover the cubitainer without any air completely. Heat the seawater at 60 deg. C using the warm water in a bath after check the cap of cubitainers is tightly closed. Heat the seawater at 85 deg. C and keep them for 5 hours in the sauna of onboard. Cool down the seawater at the room temperature and pack it.

b. Analytical detail using QuAAtro system

The phosphate analysis is a modification of the procedure of Murphy and Riley (1962).

Molybdcic acid is added to the seawater sample to form phosphomolybdcic acid which is in turn reduced to phosphomolybdous acid using L-ascorbic acid as the reductant.

Nitrate + nitrite and nitrite are analyzed according to the modification method of Grasshoff (1970). The sample nitrate is reduced to nitrite in a cadmium tube inside of which is coated with metallic copper. The sample stream with its equivalent nitrite is treated with an acidic, sulfanilamide reagent and the nitrite forms nitrous acid which reacts with the sulfanilamide to produce a diazonium ion. N-1-Naphthylethylene-diamine added to the sample stream then couples with the diazonium ion to produce a red, azo dye. With reduction of the nitrate to nitrite, both nitrate and nitrite react and are measured; without reduction, only nitrite reacts. Thus, for the nitrite analysis, no reduction is performed and the alkaline buffer is not necessary. Nitrate is computed by difference.

The silicate method is analogous to that described for phosphate. The method used is essentially that of Grasshoff et al. (1983), wherein silicomolybdcic acid is first formed from the silicate in the sample and added molybdcic acid; then the silicomolybdcic acid is reduced to silicomolybdous acid, or "molybdenum blue," using ascorbic acid as the reductant. The analytical methods of the nutrients, nitrate, nitrite, silicate and phosphate, during this cruise are same as the methods used in (Kawano et al. 2009).

The ammonia in seawater is mixed with an alkaline containing EDTA, ammonia as gas state is formed from seawater. The ammonia (gas) is absorbed in sulfuric acid by way of 0.5 µm pore size membrane filter (ADVANTEC PTFE) at the dialyzer attached to analytical system. The ammonia absorbed in sulfuric acid is determined by coupling with phenol and hypochlorite to form indophenols blue. Wavelength using ammonia analysis is 630 nm, which is absorbance of indophenols blue.

The flow diagrams and reagents for each parameter are shown in Figures 4.2-2 to 4.2-6.

c. Nitrate + Nitrite Reagents

Imidazole (buffer), 0.06 M (0.4 % w/v)

Dissolve 4 g imidazole, $C_3H_4N_2$, in ca. 1000 ml DIW; add 2 ml concentrated HCl. After mixing, 1 ml Triton®X-100 (50 % solution in ethanol) is added.

Sulfanilamide, 0.06 M (1 % w/v) in 1.2M HCl

Dissolve 10 g sulfanilamide, $4-NH_2C_6H_4SO_3H$, in 900 ml of DIW, add 100 ml concentrated HCl. After mixing, 2 ml Triton®X-100 (50 % solution in ethanol) is added.

N-1-Naphthylethylene-diamine dihydrochloride, 0.004 M (0.1 % w/v)

Dissolve 1 g NED, $C_{10}H_7NHCH_2CH_2NH_2 \cdot 2HCl$, in 1000 ml of DIW and add 10 ml concentrated HCl. After mixing, 1 ml Triton®X-100 (50 % solution in ethanol) is added. This reagent is stored in a dark bottle.

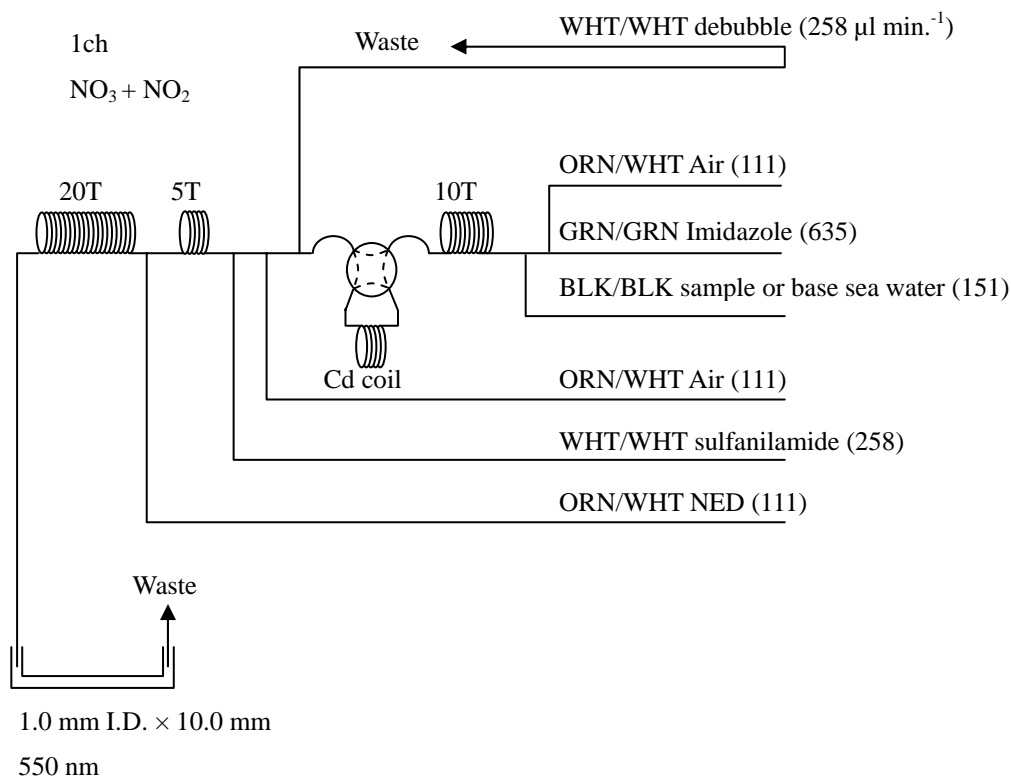

Figure 4.2-2 NO₃+NO₂ (1ch.) Flow diagram.

d. Nitrite Reagents

Sulfanilamide, 0.06 M (1 % w/v) in 1.2 M HCl

Dissolve 10g sulfanilamide, 4-NH₂C₆H₄SO₃H, in 900 ml of DIW, add 100 ml concentrated HCl. After mixing, 2 ml Triton®X-100 (50 % solution in ethanol) is added.

N-1-Naphthylethylene-diamine dihydrochloride, 0.004 M (0.1 % w/v)

Dissolve 1 g NED, C₁₀H₇NHCH₂CH₂NH₂ · 2HCl, in 1000 ml of DIW and add 10 ml concentrated HCl. After mixing, 1 ml Triton®X-100 (50 % solution in ethanol) is added. This reagent is stored in a dark bottle.

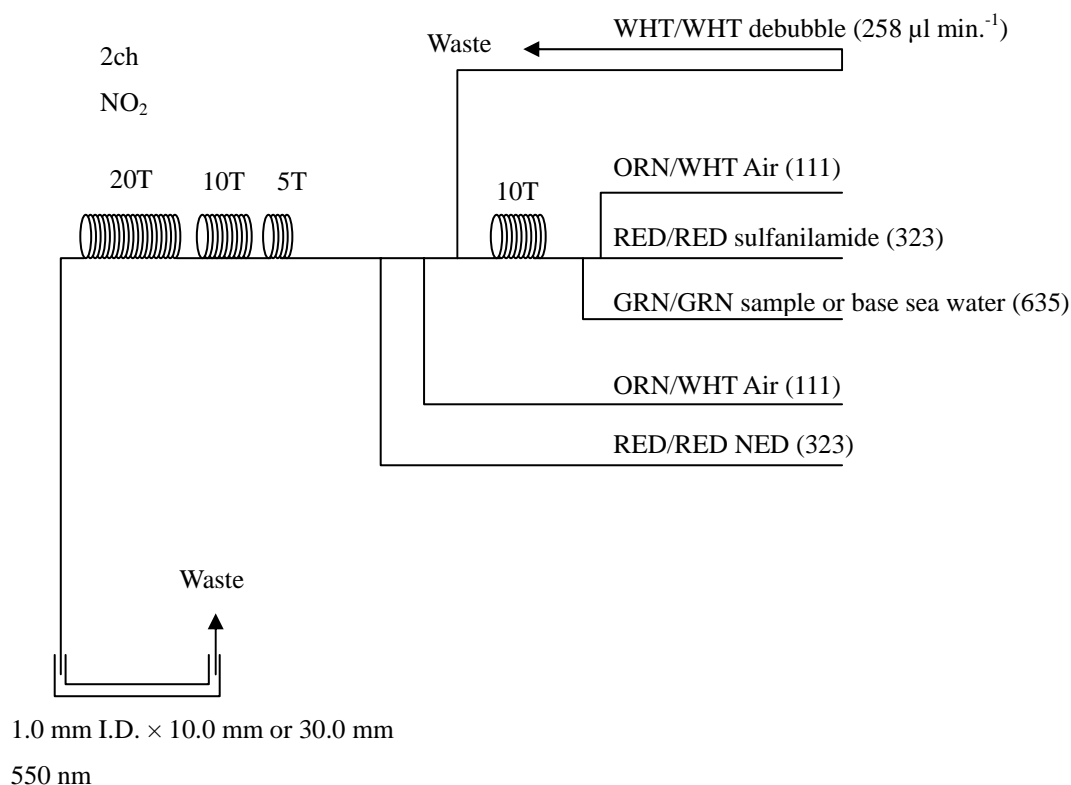

Figure 4.2-3 NO₂ (2ch.) Flow diagram.

e. Silicate Reagents

Molybdic acid, 0.06 M (2 % w/v)

Dissolve 15 g disodium molybdate(VI) dihydrate, Na₂MoO₄ · 2H₂O, in 980 ml DIW, add 8 ml concentrated H₂SO₄. After mixing, 20 ml sodium dodecyl sulphate (15 % solution in water) is added.

Oxalic acid, 0.6 M (5 % w/v)

Dissolve 50 g oxalic acid anhydrous, HOOC: COOH, in 950 ml of DIW.

Ascorbic acid, 0.01M (3 % w/v)

Dissolve 2.5g L (+)-ascorbic acid, $C_6H_8O_6$, in 100 ml of DIW. Stored in a dark bottle and freshly prepared before every measurement.

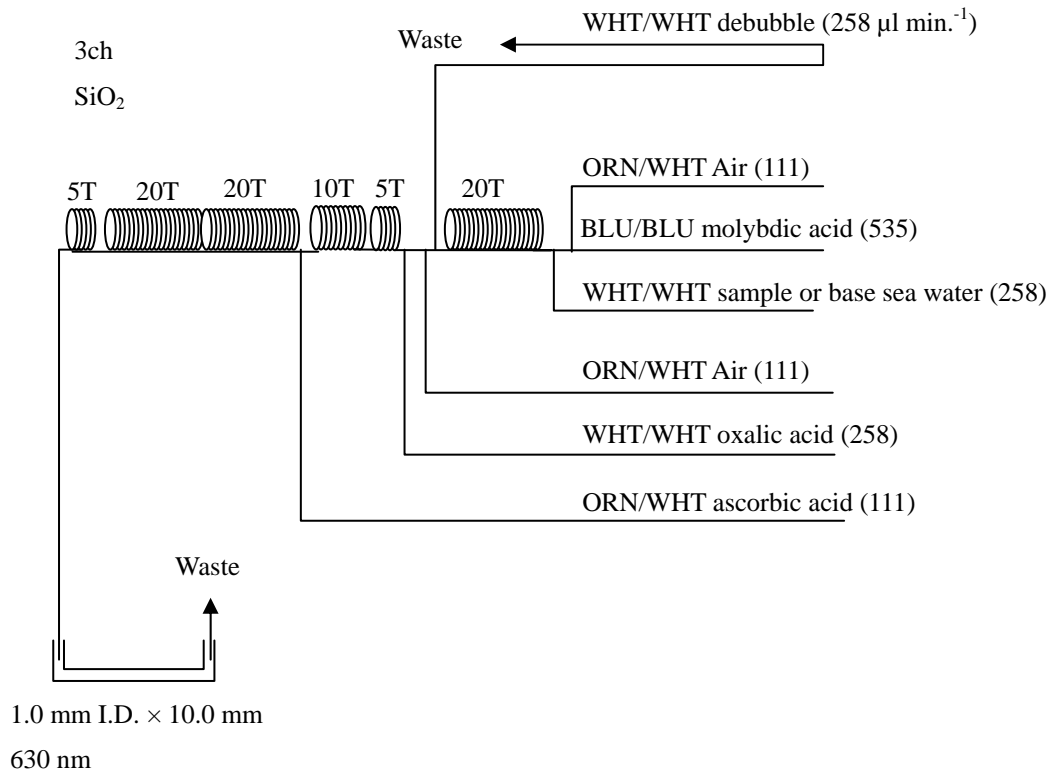

Figure4.2-4 SiO₂ (3ch.) Flow diagram.

f. Phosphate Reagents

Stock molybdate solution, 0.03M (0.8 % w/v)

Dissolve 8 g disodium molybdate(VI) dihydrate, $Na_2MoO_4 \cdot 2H_2O$, and 0.17 g antimony potassium tartrate, $C_8H_4K_2O_{12}Sb_2 \cdot 3H_2O$, in 950 ml of DIW and add 50 ml concentrated H_2SO_4 .

Mixed Reagent ···

Dissolve 0.8 g L (+)-ascorbic acid, $C_6H_8O_6$, in 100 ml of stock molybdate solution. After mixing, 2 ml sodium dodecyl sulphate (15 % solution in water) is added. Stored in a dark bottle and freshly prepared before every measurement.

Reagent for sample dilution

Dissolve sodium chloride, NaCl, 10 g in ca. 950 ml of DIW, add 50 ml acetone and 4 ml

concentrated H_2SO_4 . After mixing, 5 ml sodium dodecyl sulphate (15 % solution in water) is added.

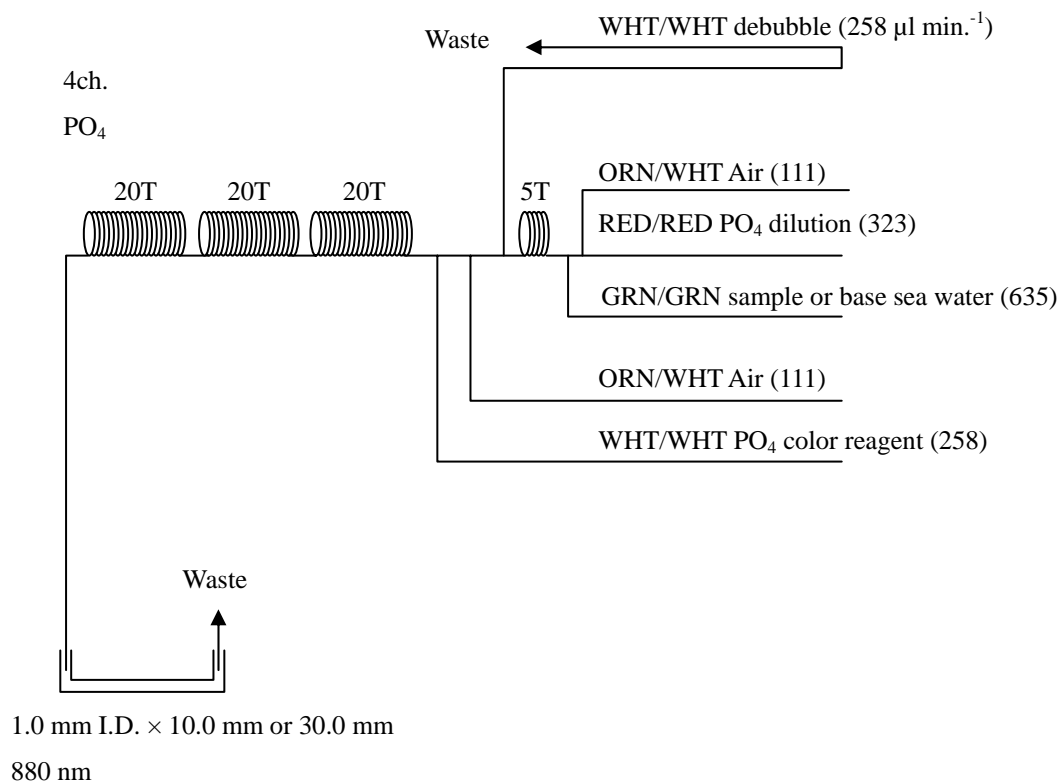

Figure 4.2-5 PO₄ (4ch.) Flow diagram.

g. Ammonia Reagents

EDTA

Dissolve 25 g EDTA (ethylenediaminetetraacetic acid tetrasodium salt), $\text{C}_{10}\text{H}_{12}\text{N}_2\text{O}_8\text{Na}_4 \cdot 4\text{H}_2\text{O}$, and 2 g boric acid, H_3BO_3 , in 200 ml of DIW. After mixing, 1 ml Triton®X-100 (30 % solution in DIW) is added. This reagent is prepared at a week about.

NaOH

Dissolve 5 g sodium hydroxide, NaOH, and 16 g EDTA in 100 ml of DIW. This reagent is prepared at a week about.

Stock Nitroprusside

Dissolved 0.25 g sodium pentacyanonitrosylferrate(II), $\text{Na}_2[\text{Fe}(\text{CN})_5\text{NO}]$, in 100 ml of DIW and add 0.2 ml 1N H_2SO_4 . Stored in a refrigerator with in a dark bottle and prepared at a month about.

Nitroprusside solution

Mixed 4 ml stock nitroprusside and 5 ml 1N H₂SO₄ in 500 ml of DIW. After mixing, 1 ml Triton®X-100 (30 % solution in DIW) is added. This reagent is stored in a dark bottle and prepared at every 2 or 3 days.

Alkaline phenol

Dissolved 10 g phenol, C₆H₅OH, 5 g sodium hydroxide and citric acid, C₆H₈O₇, in 200 ml DIW. Stored in a dark bottle and prepared at a week about.

NaClO solution

Mixed 3 ml sodium hypochlorite solution, NaClO, in 47 ml DIW. Stored in a dark bottle and freshly prepared before every measurement. This reagent is prepared 0.3% available chlorine.

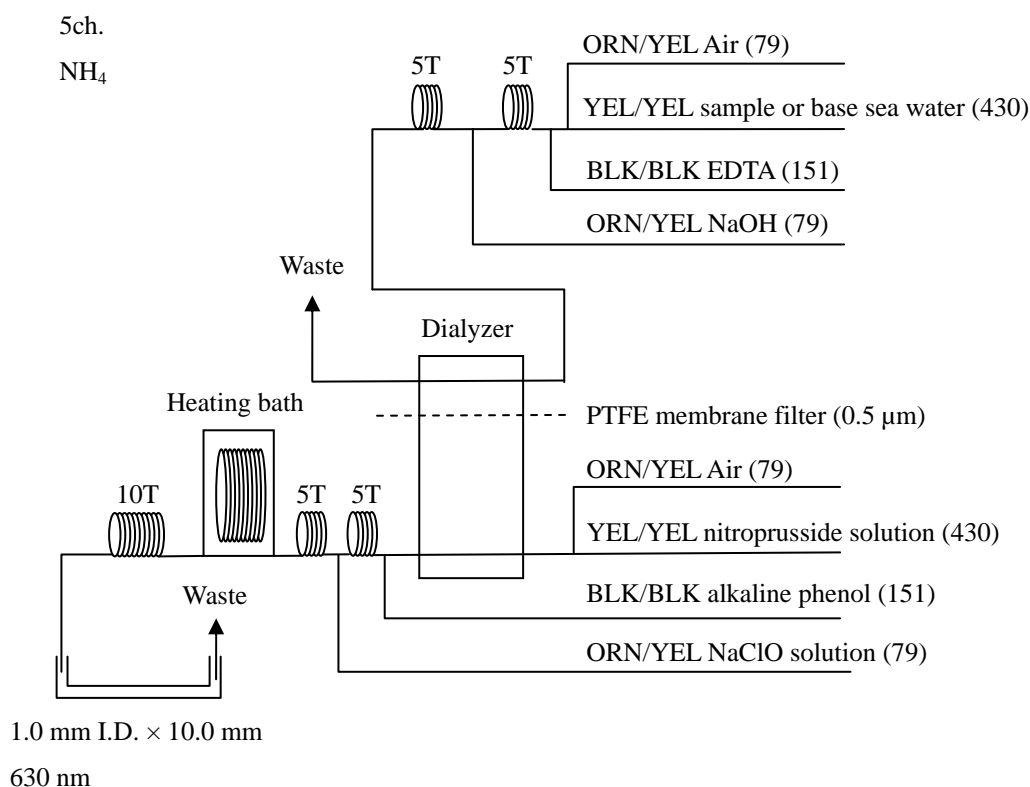

Figure 4.2-6 NH₄ (5ch.) Flow diagram.

h. Sampling procedures

Sampling of nutrients followed that oxygen, salinity and trace gases. Samples were drawn into two of virgin 10 ml polyacrylates vials without sample drawing tubes. These were rinsed three times before filling and vials were capped immediately after the

drawing. The vials are put into water bath adjusted to ambient temperature, 24 ± 1 deg. C, in about 30 minutes before use to stabilize the temperature of samples in MR10-05.

No transfer was made and the vials were set an auto sampler tray directly. Samples were analyzed after collection basically within 24 hours in MR10-05.

In Chukchi sea, we filtered out a suspended material in the sample using syringe driven unit (MILLEXR-HV, PVDF, 0.45 μm) just before analysis as occasion demands.

i. Data processing

Raw data from QuAAtro were treated as follows:

- Check baseline shift.
- Check the shape of each peak and positions of peak values taken, and then change the positions of peak values taken if necessary.
- Carry-over correction and baseline drift correction were applied to peak heights of each samples followed by sensitivity correction.
- Baseline correction and sensitivity correction were done basically using liner regression.
- Load pressure and salinity from CTD data to calculate density of seawater.
- Calibration curves to get nutrients concentration were assumed second order equations.

(5) Nutrients standards

a. Volumetric laboratory ware of in-house standards

All volumetric glass ware and polymethylpentene (PMP) ware used were gravimetrically calibrated. Plastic volumetric flasks were gravimetrically calibrated at the temperature of use within 0 to 4 K.

Volumetric flasks

Volumetric flasks of Class quality (Class A) are used because their nominal tolerances are 0.05 % or less over the size ranges likely to be used in this work. Class A flasks are made of borosilicate glass, and the standard solutions were transferred to plastic bottles as quickly as possible after they are made up to volume and well mixed in order to prevent excessive dissolution of silicate from the glass. PMP volumetric flasks were gravimetrically calibrated and used only within 0 to 4 K of the calibration temperature.

The computation of volume contained by glass flasks at various temperatures other than the calibration temperatures were done by using the coefficient of linear expansion of borosilicate crown glass.

Because of their larger temperature coefficients of cubical expansion and lack of tables constructed for these materials, the plastic volumetric flasks were gravimetrically calibrated over the temperature range of intended use and used at the temperature of calibration within 0 to 4 K. The weights obtained in the calibration weightings were corrected for the density of water and air buoyancy.

Pipettes and pipettors

All pipettes have nominal calibration tolerances of 0.1 % or better. These were gravimetrically calibrated in order to verify and improve upon this nominal tolerance.

b. Reagents, general considerations

Specifications

For nitrate standard, “potassium nitrate 99.995 suprapur®” provided by Merck, CAS No.: 7757-91-1, was used.

For phosphate standard, “potassium dihydrogen phosphate anhydrous 99.995 suprapur®” provided by Merck, CAS No.: 7778-77-0, was used.

For nitrite standard, “sodium nitrate” provided by Wako, CAS No.: 7632-00-0, was used. And assay of nitrite was determined according JIS K8019 and assays of nitrite salts were 98.04 %. We use that value to adjust the weights taken.

For the silicate standard, we use “Silicon standard solution SiO₂ in NaOH 0.5 mol/l CertiPUR®” provided by Merck, CAS No.: 1310-73-2, of which lot number is HC814662 and HC074650 are used. The silicate concentration is certified by NIST-SRM3150 with the uncertainty of 0.5 %. Factor of HC074650 is signed 1.000, however we reassigned the factor as 0.975 from the result of comparison among HC814662, HC074650 and RMNS.

For ammonia standard, “ammonia sulfate” provided by Wako, CAS No.: 7783-20-2, was used.

Ultra pure water

Ultra pure water (Milli-Q) freshly drawn was used for preparation of reagents, higher concentration standards and for measurement of reagent and system blanks.

Low-nutrients seawater (LNSW)

Surface water having low nutrient concentration was taken and filtered using 0.45 µm pore size membrane filter. This water is stored in 20 liter cubitainer with paper box. The concentrations of nutrient of this water were measured carefully in Jul 2008.

c. Concentrations of nutrients for A, B and C standards

Concentrations of nutrients for A, B and C standards are set as shown in Table 4.2-1. The C standard is prepared according recipes as shown in Table 4.2-2. All volumetric laboratory tools were calibrated prior the cruise as stated in chapter (5). Then the actual concentration of nutrients in each fresh standard was calculated based on the ambient, solution temperature and determined factors of volumetric laboratory wares.

The calibration curves for each run were obtained using 4 levels, C-1, C-2, C-3 and C-4.

Table 4.2-1 Nominal concentrations of nutrients for A, B and C standards.

	A	B	C-1	C-2	C-3	C-4
NO ₃ (µM)	22000	670	0.03	7	20	34
NO ₂ (µM)	4000	20	0.00	0.2	0.6	1
SiO ₂ (µM)	36000	1400	0.80	15	40	70
PO ₄ (µM)	3000	60	0.03	0.6	1.8	3
NH ₄ (µM)	4000	160	0.00	1.6	3.2	6

Table 4.2-2 Working calibration standard recipes.

C Std.	B-1 Std.	B-2 Std.	B-3 Std.	DIW
C-1	0 ml	0 ml	0 ml	70 ml
C-2	5 ml	5 ml	5 ml	55 ml
C-3	15 ml	15 ml	10 ml	30 ml
C-4	25 ml	25 ml	20 ml	0 ml

B-1 Std.: Mixture of nitrate, silicate and phosphate

B-2 Std.: Nitrite

B-3 Std.: Ammonia

d. Renewal of in-house standard solutions

In-house standard solutions as stated in paragraph c were renewed as shown in Table 4.2-3(a) to (c).

Table 4.2-3(a) Timing of renewal of in-house standards.

NO ₃ , NO ₂ , SiO ₂ , PO ₄ , NH ₄	Renewal
A-1 Std. (NO ₃)	maximum 1 month
A-2 Std. (NO ₂)	maximum 1 month
A-3 Std. (SiO ₂)	commercial prepared solution
A-4 Std. (PO ₄)	maximum 1 month
A-5 Std. (NH ₄)	maximum 1 month
B-1 Std. (mixture of NO ₃ , SiO ₂ , PO ₄)	8 days
B-2 Std. (NO ₂)	8 days
B-3 Std. (NH ₄)	8 days

Table 4.2-3(b) Timing of renewal of working calibration standards.

C Std.	Renewal
C Std. (mixture of B-1, B-2 and B-3 Std.)	24 hours

Table 4.2-3(c) Timing of renewal of in-house standards for reduction estimation.

Reduction estimation	Renewal
D-1 Std. (3600 $\mu\text{M NO}_3$)	8 days
22 $\mu\text{M NO}_3$	when C Std. renewed
24 $\mu\text{M NO}_2$	when C Std. renewed

(6) Reference material of nutrients in seawater

To get the more accurate and high quality nutrients data to achieve the objectives stated above, huge numbers of the bottles of the reference material of nutrients in seawater (hereafter RMNS) are prepared (Aoyama et al., 2006, 2007, 2008, 2009). In the previous worldwide expeditions, such as WOCE cruises, the higher reproducibility and precision of nutrients measurements were required (Joyce and Corry, 1994). Since no standards were available for the measurement of nutrients in seawater at that time, the requirements were described in term of reproducibility. The required reproducibility was 1 %, 1 to 2 %, 1 to 3 % for nitrate, phosphate and silicate, respectively. Although nutrient data from the WOCE one-time survey was of unprecedented quality and coverage due to much care in sampling and measurements, the differences of nutrients concentration at crossover points are still found among the expeditions (Aoyama and Joyce, 1996, Mordy et al., 2000, Gouretski and Jancke, 2001). For instance, the mean offset of nitrate concentration at deep waters was $0.5 \mu\text{mol kg}^{-1}$ for 345 crossovers at world oceans, though the maximum was $1.7 \mu\text{mol kg}^{-1}$ (Gouretski and Jancke, 2001). At the 31 crossover points in the Pacific WHP one-time lines, the WOCE standard of reproducibility for nitrate of 1 % was fulfilled at about half of the crossover points and the maximum difference was 7 % at deeper layers below 1.6 deg. C in potential temperature (Aoyama and Joyce, 1996).

a. RMNS for this cruise

RMNS lots BA, AY, AX, BD and AR, which cover full range of nutrients concentrations in the Arctic ocean are prepared. 50 sets of BA, AY, AX, BD and AR are prepared.

These RMNS assignment were completely done based on random number. The RMNS bottles were stored at a room in the ship, REAGENT STORE, where the temperature was maintained around 20 deg. C.

b. Assigned concentration for RMNSs

We assigned nutrients concentrations for RMNS lots BA, AY, AX, BD and AR as shown in Table 4.2-4.

Table 4.2-4 Assigned concentration of RMNSs.

	unit: $\mu\text{mol kg}^{-1}$				
	Nitrate	Phosphate	Silicate	Nitrite	Ammonia
BA	0.07	0.061	1.61	0.02	0.97
AY	5.61	0.516	29.40	0.63	0.81
AX	21.44	1.614	58.05	0.35	0.69
BD	29.74	2.176	64.43	0.03	2.45
AR	0.10	0.064	2.02	0.02	4.97

(7) Quality control

a. Precision of nutrients analyses during the cruise

Precision of nutrients analyses during the cruise was evaluated based on the 5 to 7 measurements, which are measured every 5 to 13 samples, during a run at the concentration of C-4 std. Summary of precisions are shown as shown in Table 4.2-7 and Figures 4.2-17 to 4.2-21, Analytical precisions previously evaluated were 0.08 % for nitrate, 0.10 % for phosphate and 0.07 % for silicate in WOCE P21 revisited cruise of MR09-01 cruise in 2009, respectively. During this cruise, analytical precisions were 0.12% for nitrate, 0.12 % for phosphate, 0.18 % for silicate and 0.37 % for ammonia in terms of median of precision, respectively. Then we can conclude that the analytical precisions for nitrate, phosphate and silicate were maintained throughout this cruise. The time series of precision are shown in Figures 4.2-5 to 4.2-7.

Table 4.2-7 Summary of precision based on the replicate analyses.

	Nitrate	Phosphate	Silicate	Ammonia
	CV %	CV %	CV %	CV%
Median	0.12	0.12	0.18	0.37
Mean	0.12	0.12	0.19	0.40
Maximum	0.47	0.24	0.67	1.34
Minimum	0.02	0.04	0.04	0.04
N	125	125	125	125

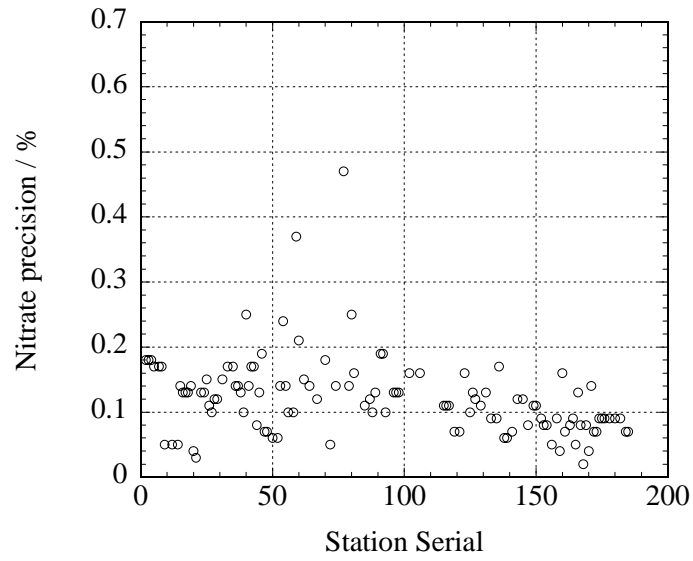

Figure 4.2-17 Time series of precision of nitrate for MR10-05.

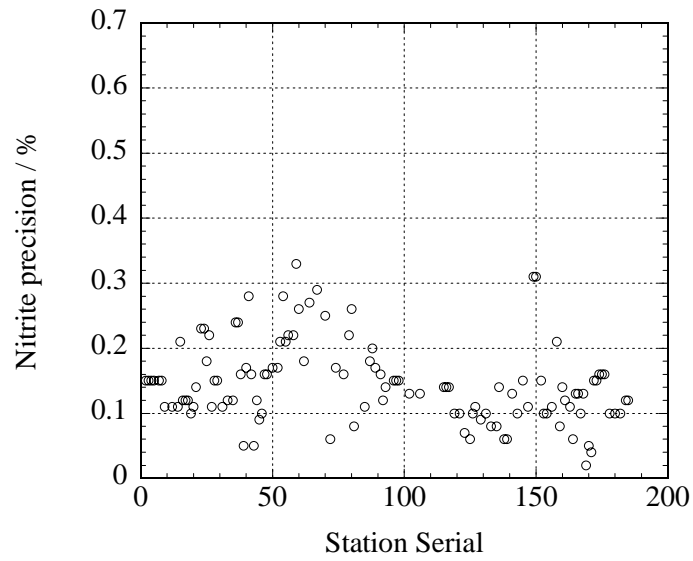

Figure 4.2-18 Time series of precision of nitrite for MR10-05.

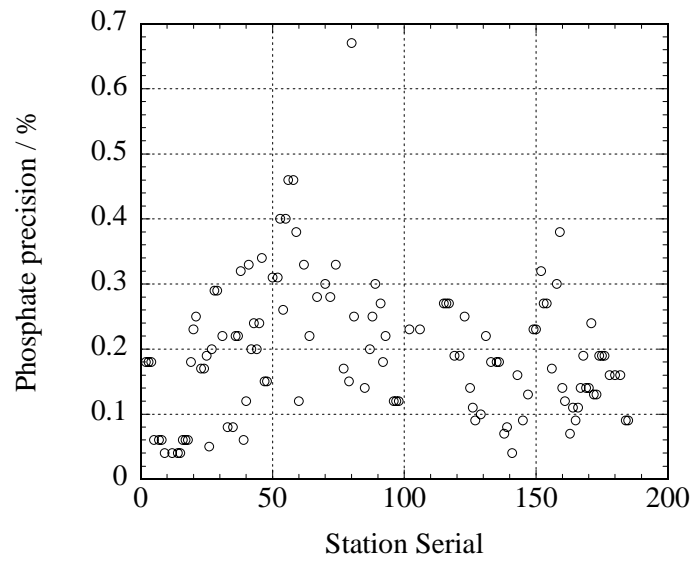

Figure 4.2-19 Time series of precision of phosphate for MR10-05.

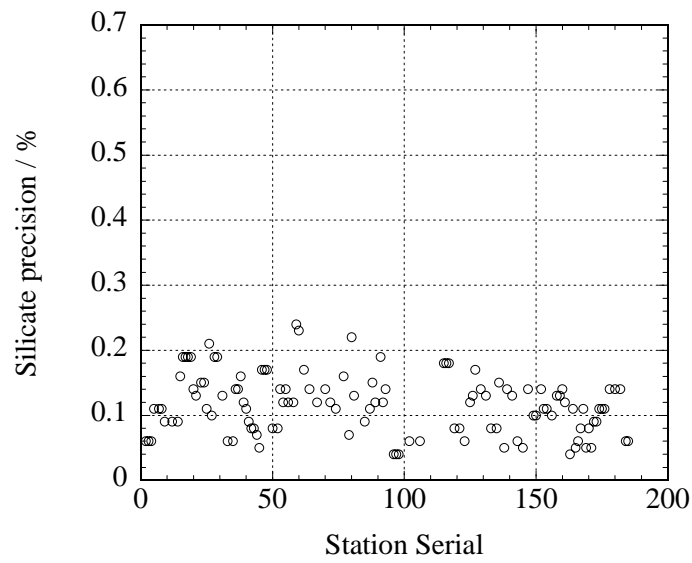

Figure 4.2-20 Time series of precision of silicate for MR10-05.

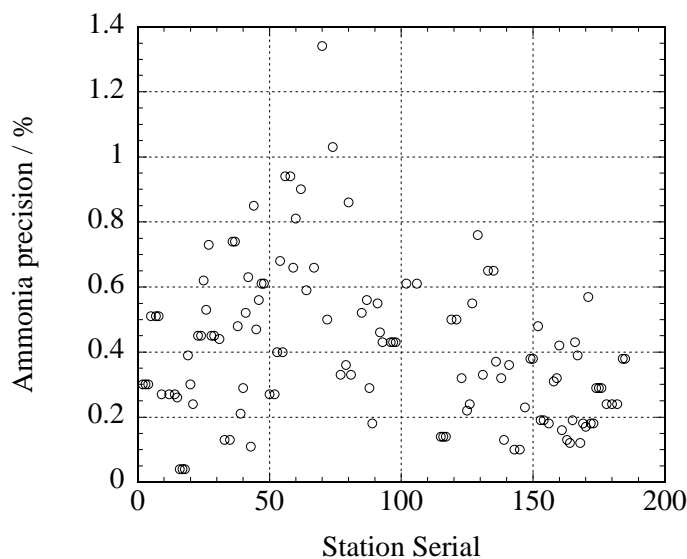

Figure 4.2-21 Time series of precision of ammonia for MR10-05.

b. Carry over

We can also summarize the magnitudes of carry over throughout the cruise. These are small enough within acceptable levels as shown in Table 4.2-9.

Table 4.2-9 Summary of carry over throughout MR10-05.

	Nitrate	Phosphate	Silicate	Ammonia
	%	%	%	%
Median	0.11	0.09	0.17	0.59
Mean	0.12	0.09	0.18	0.64
Maximum	0.36	0.35	0.99	2.22
Minimum	0.00	0.00	0.00	0.00
N	125	125	125	125

(8) Problems/improvements occurred and solutions.

a. Deterioration of pump tubes of QuAAtro

We used pump tubes of QuAAtro, standard pump tube by BL TEC. The pump tube, especially sample line, was deteriorated at 40 to 80 hours. Therefore, we need to examine a material of the pump tube.

b. Precipitation at ammonia line

There was a precipitation at the point of mixed seawater sample, EDTA and NaOH in ammonia line. We need to examine the quantity of EDTA.

c. Noises accompanying the ship's rolling at the rough weather

When the rough weather, noises were detected in all parameter chart. We attached a

damper for removed vibration under the QuAAtro. However, we could not remove noises completely.

(9) Station list

Table 4.2-10 List of stations

Cruise	Leg	Station	Year	Month	Date	Latitude	Longitude
MR1005	2	1	2010	9	5	65.756 N	191.503 E
MR1005	2	2	2010	9	5	65.714 N	191.746 E
MR1005	2	3	2010	9	5	65.819 N	191.168 E
MR1005	2	4	2010	9	5	66.005 N	191.17 E
MR1005	2	6	2010	9	5	67.002 N	191.163 E
MR1005	2	7	2010	9	5	67.666 N	191.077 E
MR1005	2	8	2010	9	6	68.001 N	191.165 E
MR1005	2	10	2010	9	6	69.001 N	191.161 E
MR1005	2	12	2010	9	6	70 N	192.002 E
MR1005	2	13	2010	9	6	71 N	191.998 E
MR1005	2	14	2010	9	7	72.001 N	192.004 E
MR1005	2	15	2010	9	7	73 N	191.999 E
MR1005	2	16	2010	9	7	74.001 N	191.996 E
MR1005	2	17	2010	9	7	74.998 N	191.993 E
MR1005	2	18	2010	9	8	74.602 N	189.063 E
MR1005	2	19	2010	9	8	74.255 N	197.41 E
MR1005	2	20	2010	9	9	74.002 N	196.775 E
MR1005	2	21	2010	9	9	73.671 N	195.899 E
MR1005	2	22	2010	9	10	71.963 N	209.767 E
MR1005	2	23	2010	9	11	71.659 N	208.767 E
MR1005	2	24	2010	9	11	71.502 N	208.343 E
MR1005	2	25	2010	9	11	71.455 N	208.192 E
MR1005	2	26	2010	9	11	71.367 N	207.881 E
MR1005	2	28	2010	9	10	71.735 N	204.902 E
MR1005	2	30	2010	9	13	71.106 N	200.677 E
MR1005	2	31	2010	9	13	71.001 N	198 E
MR1005	2	32	2010	9	14	72 N	198.003 E
MR1005	2	33	2010	9	14	72.999 N	198.003 E
MR1005	2	34	2010	9	14	74 N	198.005 E
MR1005	2	35	2010	9	16	78.259 N	190.008 E
MR1005	2	36	2010	9	17	78.072 N	190.658 E

MR1005	2	37	2010	9	17	77.85	N	191.61	E
MR1005	2	38	2010	9	17	77.63	N	192.527	E
MR1005	2	39	2010	9	17	76	N	184.75	E
MR1005	2	40	2010	9	18	76.45	N	179.6	E
MR1005	2	41	2010	9	19	76.001	N	178.904	E
MR1005	2	42	2010	9	19	75.411	N	178.212	E
MR1005	2	43	2010	9	19	75.233	N	177.984	E
MR1005	2	44	2010	9	19	75	N	177.718	E
MR1005	2	46	2010	9	20	74.998	N	179.998	E
MR1005	2	47	2010	9	20	74.998	N	181.995	E
MR1005	2	48	2010	9	20	75	N	183.994	E
MR1005	2	49	2010	9	20	75.25	N	185.989	E
MR1005	2	50	2010	9	20	75	N	185.998	E
MR1005	2	51	2010	9	21	74.751	N	185.997	E
MR1005	2	52	2010	9	21	75	N	187.995	E
MR1005	2	53	2010	9	21	75.4	N	185.998	E
MR1005	2	54	2010	9	21	75.584	N	186	E
MR1005	2	56	2010	9	22	76.252	N	186.007	E
MR1005	2	58	2010	9	22	76.668	N	188.003	E
MR1005	2	60	2010	9	22	77.083	N	190.002	E
MR1005	2	62	2010	9	23	77.143	N	191.068	E
MR1005	2	63	2010	9	23	77.175	N	191.613	E
MR1005	2	65	2010	9	23	77.263	N	193.661	E
MR1005	2	68	2010	9	24	79.189	N	195.025	E
MR1005	2	70	2010	9	24	78.867	N	195.002	E
MR1005	2	71	2010	9	24	77.765	N	196.215	E
MR1005	2	72	2010	9	25	77.757	N	198.001	E
MR1005	2	75	2010	9	26	76.975	N	199.93	E
MR1005	2	77	2010	9	26	76.615	N	202.987	E
MR1005	2	78	2010	9	26	76.392	N	205.26	E
MR1005	2	79	2010	9	27	75.512	N	204.72	E
MR1005	2	81	2010	9	27	75.663	N	203.716	E
MR1005	2	82	2010	9	27	75.747	N	202.901	E
MR1005	2	83	2010	9	28	75.865	N	201.916	E
MR1005	2	86	2010	9	29	71	N	198.002	E
MR1005	2	87	2010	9	29	71.106	N	200.677	E
MR1005	2	88	2010	9	29	71.249	N	202.841	E
MR1005	2	92	2010	9	29	71.413	N	202.509	E
MR1005	2	96	2010	9	29	71.577	N	202.161	E

MR1005	2	105	2010	9	30	71.601	N	205.162	E
MR1005	2	106	2010	9	30	72.183	N	202.819	E
MR1005	2	107	2010	9	30	72.5	N	200.003	E
MR1005	2	109	2010	9	30	72.683	N	200.599	E
MR1005	2	111	2010	9	30	72.883	N	201.201	E
MR1005	2	113	2010	10	1	73.15	N	202.002	E
MR1005	2	115	2010	10	1	73.477	N	203.007	E
MR1005	2	116	2010	10	2	74.072	N	204.672	E
MR1005	2	117	2010	10	2	74.399	N	202.994	E
MR1005	2	119	2010	10	2	74.678	N	201.686	E
MR1005	2	121	2010	10	3	74.379	N	194.73	E
MR1005	2	123	2010	10	3	74.113	N	193.213	E
MR1005	2	125	2010	10	3	73.982	N	192.402	E
MR1005	2	126	2010	10	4	75	N	197.996	E
MR1005	2	128	2010	10	4	76.002	N	194.501	E
MR1005	2	128	2010	10	4	76.624	N	191.92	E
MR1005	2	129	2010	10	5	76.624	N	191.92	E
MR1005	2	131	2010	10	5	76.517	N	193.136	E
MR1005	2	133	2010	10	5	76.263	N	195.025	E
MR1005	2	135	2010	10	6	75.737	N	197.055	E
MR1005	2	137	2010	10	6	75	N	194.99	E
MR1005	2	139	2010	10	6	75.004	N	192.768	E
MR1005	2	140	2010	10	6	75	N	192	E
MR1005	2	142	2010	10	6	75	N	189.996	E
MR1005	2	143	2010	10	7	73.714	N	197.237	E
MR1005	2	144	2010	10	7	73.057	N	196.255	E
MR1005	2	146	2010	10	7	73.48	N	199.003	E
MR1005	2	148	2010	10	8	73.79	N	200.999	E
MR1005	2	149	2010	10	8	73.72	N	203.316	E
MR1005	2	150	2010	10	8	73.59	N	202.348	E
MR1005	2	151	2010	10	9	73.745	N	201.57	E
MR1005	2	153	2010	10	9	73.901	N	200.782	E
MR1005	2	154	2010	10	9	74.017	N	202.497	E
MR1005	2	155	2010	10	9	73.901	N	201.749	E
MR1005	2	156	2010	10	10	73.715	N	200.491	E
MR1005	2	157	2010	10	10	73.961	N	200.496	E
MR1005	2	158	2010	10	10	74.185	N	199.5	E
MR1005	2	159	2010	10	10	74.501	N	195.507	E
MR1005	2	160	2010	10	11	74.623	N	196.254	E

MR1005	2	161	2010	10	11	74.751	N	197.004	E
MR1005	2	162	2010	10	11	74.002	N	197.991	E
MR1005	2	163	2010	10	11	73	N	198.003	E
MR1005	2	164	2010	10	12	70.999	N	198.001	E
MR1005	2	165	2010	10	12	70.496	N	195.245	E
MR1005	2	166	2010	10	12	69.999	N	192.001	E
MR1005	2	168	2010	10	13	69	N	191.166	E
MR1005	2	170	2010	10	13	68	N	191.167	E
MR1005	2	172	2010	10	13	67.002	N	191.168	E
MR1005	2	174	2010	10	13	66.001	N	191.167	E
MR1005	2	175	2010	10	13	65.755	N	191.502	E

(10) Data archive

These data obtained in this cruise will be submitted to the Data Management Office (DMO) of JAMSTEC, and will be opened to the public via “R/V Mirai Data Web Page” in JAMSTEC home page.

References

- Aminot, A. and Kerouel, R. 1991. Autoclaved seawater as a reference material for the determination of nitrate and phosphate in seawater. *Anal. Chim. Acta*, 248: 277-283.
- Aminot, A. and Kirkwood, D.S. 1995. Report on the results of the fifth ICES intercomparison exercise for nutrients in sea water, ICES coop. Res. Rep. Ser., 213.
- Aminot, A. and Kerouel, R. 1995. Reference material for nutrients in seawater: stability of nitrate, nitrite, ammonia and phosphate in autoclaved samples. *Mar. Chem.*, 49: 221-232.
- Aoyama M., and Joyce T.M. 1996, WHP property comparisons from crossing lines in North Pacific. In Abstracts, 1996 WOCE Pacific Workshop, Newport Beach, California.
- Aoyama, M., 2006: 2003 Intercomparison Exercise for Reference Material for Nutrients in Seawater in a Seawater Matrix, Technical Reports of the Meteorological Research Institute No.50, 91pp, Tsukuba, Japan.
- Aoyama, M., Susan B., Minhan, D., Hideshi, D., Louis, I. G., Kasai, H., Roger, K., Nurit, K., Doug, M., Murata, A., Nagai, N., Ogawa, H., Ota, H., Saito, H., Saito, K., Shimizu, T., Takano, H., Tsuda, A., Yokouchi, K., and Agnes, Y. 2007. Recent Comparability of Oceanographic Nutrients Data: Results of a 2003 Intercomparison Exercise Using Reference Materials. *Analytical Sciences*, 23: 1151-1154.
- Aoyama M., J. Barwell-Clarke, S. Becker, M. Blum, Braga E. S., S. C. Coverly, E. Czobik, I. Dahllhof, M. H. Dai, G. O. Donnell, C. Engelke, G. C. Gong, Gi-Hoon Hong, D. J. Hydes, M. M. Jin, H. Kasai, R. Kerouel, Y. Kiyomono, M. Knockaert, N. Kress, K. A. Kroglund, M. Kumagai, S. Leterme, Yarong Li, S. Masuda, T. Miyao, T. Moutin, A. Murata, N.

- Nagai, G., Nausch, M. K., Ngirchchol, A., Nybakk, H., Ogawa, J., van Ooijen, H., Ota, J. M., Pan, C., Payne, O., Pierre-Duplessix, M., Pujo-Pay, T., Raabe, K., Saito, K., Sato, C., Schmidt, M., Schuett, T. M., Shammon, J., Sun, T., Tanhua, L., White, E.M.S., Woodward, P., Worsfold, P., Yeats, T., Yoshimura, A., Youenou, J., Z. Zhang, 2008: 2006 Intercomparison Exercise for Reference Material for Nutrients in Seawater in a Seawater Matrix, Technical Reports of the Meteorological Research Institute No. 58, 104pp.
- Gouretski, V.V. and Jancke, K. 2001. Systematic errors as the cause for an apparent deep water property variability: global analysis of the WOCE and historical hydrographic data • REVIEW ARTICLE, *Progress In Oceanography*, 48: Issue 4, 337-402.
- Grasshoff, K., Ehrhardt, M., Kremling K. et al. 1983. *Methods of seawater analysis*. 2nd rev. Weinheim: Verlag Chemie, Germany, West.
- Joyce, T. and Corry, C. 1994. Requirements for WOCE hydrographic programmed data reporting. WHP0 Publication, 90-1, Revision 2, WOCE Report No. 67/91.
- Kawano, T., Uchida, H. and Doi, T. WHP P01, P14 REVISIT DATA BOOK, (Ryoin Co., Ltd., Yokohama, 2009).
- Kirkwood, D.S. 1992. Stability of solutions of nutrient salts during storage. *Mar. Chem.*, 38 : 151-164.
- Kirkwood, D.S., Aminot, A. and Perttila, M. 1991. Report on the results of the ICES fourth intercomparison exercise for nutrients in sea water. ICES coop. Res. Rep. Ser., 174.
- Mordy, C.W., Aoyama, M., Gordon, L.I., Johnson, G.C., Key, R.M., Ross, A.A., Jennings, J.C. and Wilson. J. 2000. Deep water comparison studies of the Pacific WOCE nutrient data set. *Eos Trans-American Geophysical Union*. 80 (supplement), OS43.
- Murphy, J., and Riley, J.P. 1962. *Analytica chim. Acta* 27, 31-36.
- Uchida, H. & Fukasawa, M. WHP P6, A10, I3/I4 REVISIT DATA BOOK Blue Earth Global Expedition 2003 1, 2, (Aiwa Printing Co., Ltd., Tokyo, 2005).

4.3. Underway surface water monitoring

(1) Personnel

Shigeto NISHINO (JAMSTEC): Principal Investigator

Hironori SATO (MWJ): Operation Leader

Fuyuki SHIBATA (MWJ)

Misato KUWAHARA (MWJ)

(2) Objective

Our purpose is to obtain temperature, salinity, dissolved oxygen, and fluorescence data continuously in near-sea surface water.

(3) Parameters

Temperature (surface water)

Salinity (surface water)

Dissolved oxygen (surface water)

Fluorescence (surface water)

(4) Instruments and Methods

The Continuous Sea Surface Water Monitoring System (Marine Works Japan Co. Ltd.) has five sensors and automatically measures temperature, salinity, dissolved oxygen and fluorescence in near-sea surface water every one minute. This system is located in the “*sea surface monitoring laboratory*” and connected to shipboard LAN-system. Measured data, time, and location of the ship were stored in a data management PC. The near-surface water was continuously pumped up to the laboratory from about 4.5 m water depth and flowed into the system through a vinyl-chloride pipe. The flow rate of the surface seawater was adjusted to be $5 \text{ dm}^3 \text{ min}^{-1}$.

a. Instruments

Software

Seamoni-kun Ver.1.10

Sensors

Specifications of the each sensor in this system are listed below.

Temperature and Conductivity sensor

Model:	SBE-45, SEA-BIRD ELECTRONICS, INC.
Serial number:	4557820-0319
Measurement range:	Temperature -5 to +35 °C Conductivity 0 to 7 S m ⁻¹
Initial accuracy:	Temperature 0.002 °C Conductivity 0.0003 S m ⁻¹
Typical stability (per month):	Temperature 0.0002 °C Conductivity 0.0003 S m ⁻¹
Resolution:	Temperatures 0.0001 °C Conductivity 0.00001 S m ⁻¹

Bottom of ship thermometer

Model:	SBE 38, SEA-BIRD ELECTRONICS, INC.
Serial number:	3857820-0540
Measurement range:	-5 to +35 °C
Initial accuracy:	±0.001 °C
Typical stability (per 6 month):	0.001 °C
Resolution:	0.00025 °C

Dissolved oxygen sensor

Model:	OPTODE 3835, AANDERAA Instruments.
Serial number:	1233
Measuring range:	0 - 500 µmol dm ⁻³
Resolution:	<1 µmol dm ⁻³
Accuracy:	<8 µmol dm ⁻³ or 5% whichever is greater
Settling time:	<25 s

Fluorometer

2010/08/25 ~ 2010/09/23

Model:	C3, TURNER DESIGNS
Serial number:	2300123

2010/09/28 ~ 2010/10/15

Model:	10-AU, TURNER DESIGNS
Serial number:	5562 FRXX

b. Measurements

Periods of measurement, maintenance, and problems during MR10-05 are listed in Table 4.3-1.

Table 4.3-1. Events list of the Sea surface water monitoring during MR10-05

System Date [UTC]	System Time [UTC]	Events	Remarks
2010/08/25	09:46	All the measurements started and data was available.	Leg 1 start
2010/09/01	16:28	All the measurements stopped.	Leg 1 end
2010/09/02	19:17	All the measurements started and data was available.	Leg 2 start
2010/09/04	00:25	Low flow (<0.2 dm ³ min ⁻¹)	Data was deleted.
2010/09/12	23:58	Low flow (<0.2 dm ³ min ⁻¹)	Data was deleted.
2010/09/13	00:21	All the measurements stopped.	maintenance
2010/09/13	00:54	All the measurements started and data was available.	
2010/09/23	08:00	Fluorometer (C3) measurement stopped.	C3 was out of order.
2010/09/23	13:56	T, S, DO measurements stopped.	maintenance
2010/09/23	13:58	T, S, DO measurements started.	
2010/09/23	14:49	T, S, DO measurements stopped.	maintenance
2010/09/23	16:28	T, S, DO measurements started.	
2010/09/26	06:36	T, S, DO measurements stopped.	maintenance
2010/09/26	07:36	T, S, DO measurements started and data was available.	
2010/09/28	02:36	T, S, DO measurements stopped.	maintenance
2010/09/28	02:55	T, S, DO measurements started and data was available.	
2010/09/28	06:04	Fluorometer (10-AU) measurement started.	
2010/09/29	11:02	Low flow (<0.2 dm ³ min ⁻¹)	Data was deleted.
2010/09/29	23:53	Fluorometer (10-AU) data was not acquisition.	
2010/09/30	00:18		

2010/10/03	21:26~21:28	Low flow (<0.2 dm ³ min ⁻¹)	Data was deleted.
2010/10/04	04:55	Low flow (<0.2 dm ³ min ⁻¹)	Data was deleted.
2010/10/04	05:04	Low flow (<0.2 dm ³ min ⁻¹)	Data was deleted.
2010/10/04	05:28	Low flow (<0.2 dm ³ min ⁻¹)	Data was deleted.
2010/10/04	05:49	Low flow (<0.2 dm ³ min ⁻¹)	Data was deleted.
2010/10/04	05:51	Low flow (<0.2 dm ³ min ⁻¹)	Data was deleted.
2010/10/04	05:55	Low flow (<0.2 dm ³ min ⁻¹)	Data was deleted.
2010/10/04	05:57	Low flow (<0.2 dm ³ min ⁻¹)	Data was deleted.
2010/10/04	07:22	Low flow (<0.2 dm ³ min ⁻¹)	Data was deleted.
2010/10/04	07:53	Low flow (<0.2 dm ³ min ⁻¹)	Data was deleted.
2010/10/04	07:55	Low flow (<0.2 dm ³ min ⁻¹)	Data was deleted.
2010/10/04	08:09	Low flow (<0.2 dm ³ min ⁻¹)	Data was deleted.
2010/10/04	08:11	Low flow (<0.2 dm ³ min ⁻¹)	Data was deleted.
2010/10/04	08:14	Low flow (<0.2 dm ³ min ⁻¹)	Data was deleted.
2010/10/04	08:16	Low flow (<0.2 dm ³ min ⁻¹)	Data was deleted.
2010/10/04	08:18~08:19	Low flow (<0.2 dm ³ min ⁻¹)	Data was deleted.
2010/10/04	08:34	Low flow (<0.2 dm ³ min ⁻¹)	Data was deleted.
2010/10/09	00:39	Fluorometer (10-AU) value was invalid.	Maintenance
2010/10/10	07:29	Fluorometer (10-AU) value was invalid.	Maintenance
2010/10/12	06:54	All the measurements stopped.	Maintenance
2010/10/12	07:16	All the measurements started.	
2010/10/15	23:27	All the measurements stopped.	Leg 2 end

(5) Preliminary Result

Preliminary data of temperature, salinity, dissolved oxygen and fluorescence at sea surface is shown in Fig. 4.3-1.

Since 2010/9/23 8:00(UTC), we could not receive Fluorometer C3 data. We didn't know why, maybe C3 was out of order. So we changed Fluorometer from C3 to 10-AU. Since 2010/9/28 6:04(UTC), we restarted to obtain fluorescence data.

We took the surface water samples once a day to compare sensor data with bottle data of salinity, dissolved oxygen and fluorescence. The results are shown in Figs. 4.3-2 - 4. All the salinity samples were analyzed by the Guideline 8400B "AUTOSAL" (see 3.2), and dissolve oxygen samples were analyzed by Winkler method (see 4.1), and

fluorescence were analyzed by 10-AU (see 4.8).

(6) Data archive

These data obtained in this cruise will be submitted to the Data Management Office (DMO) of JAMSTEC, and will be opened to the public via “R/V Mirai Data Web Page” in JAMSTEC home page.

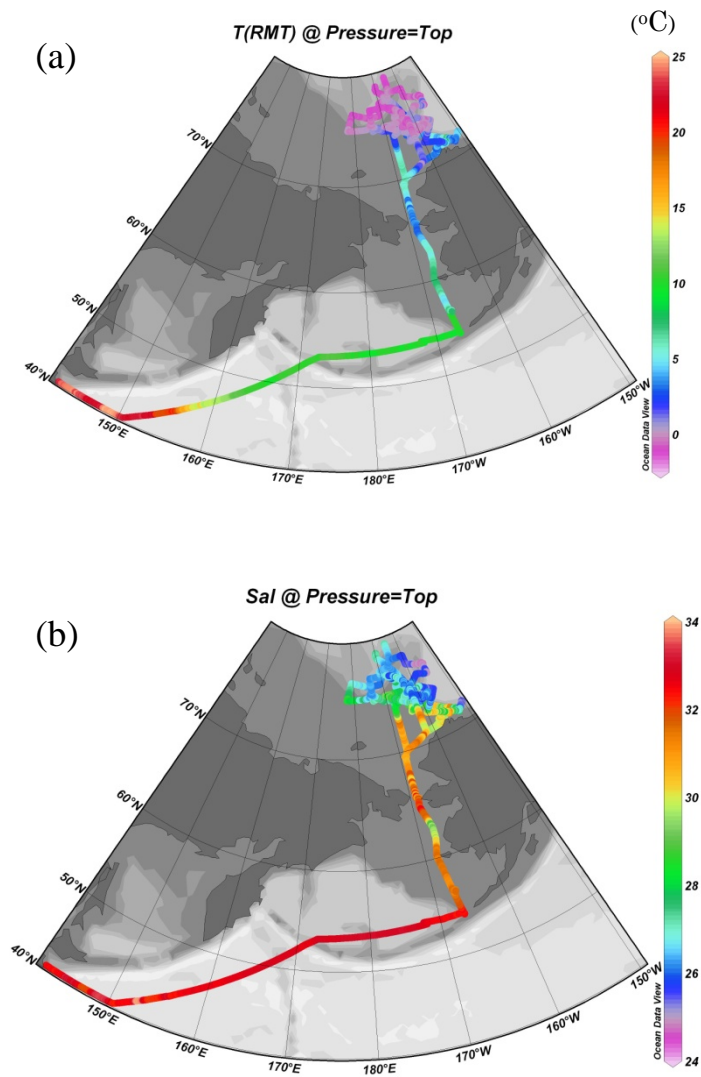

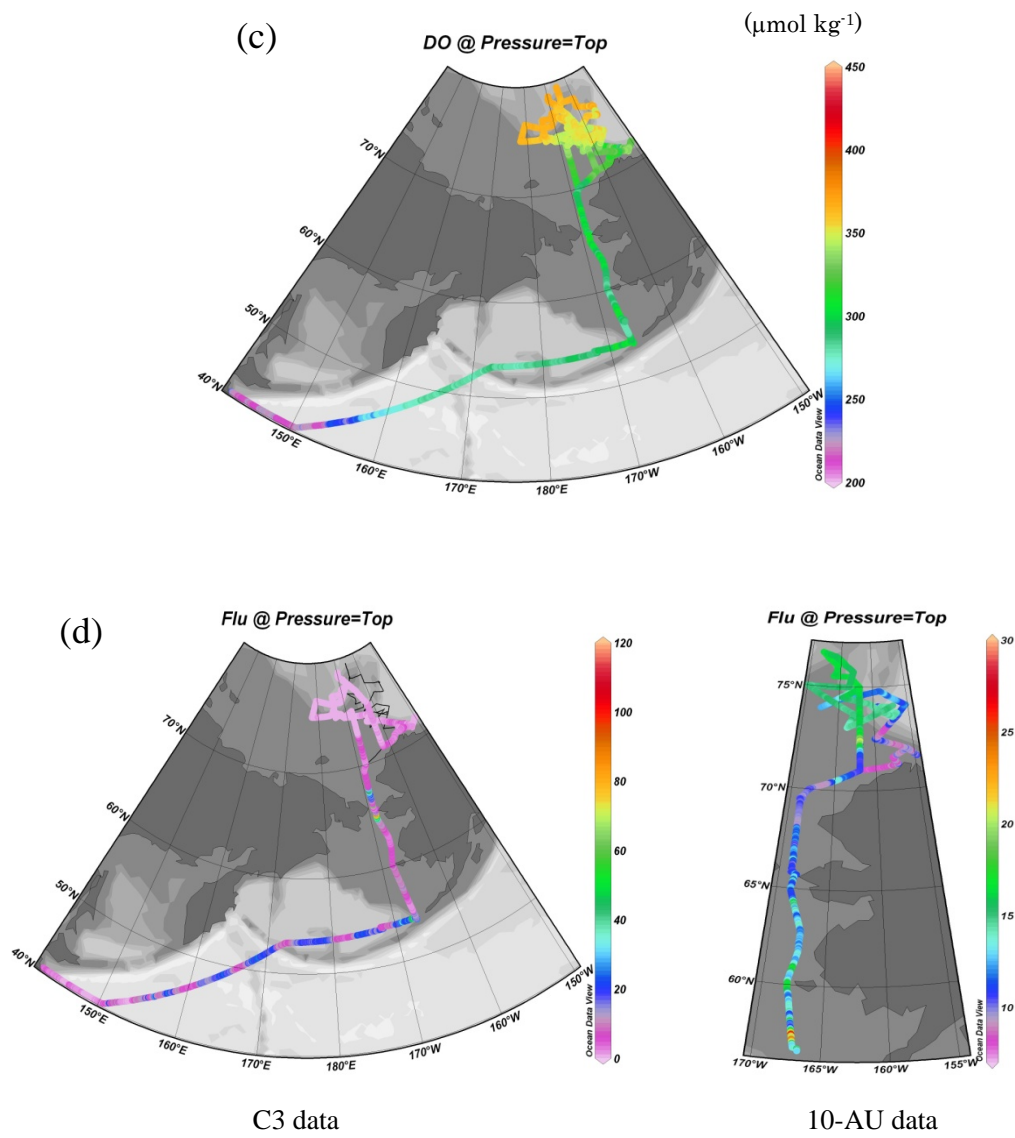

Fig. 4.3-1. Spatial and temporal distribution of (a) temperature, (b) salinity, (c) dissolved oxygen and (d) fluorescence in MR10-05 cruise.

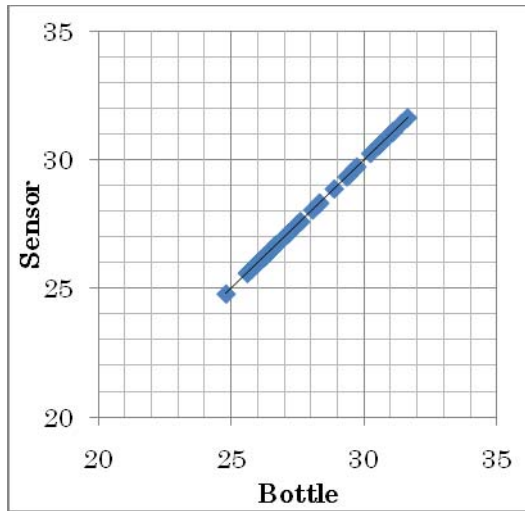

Fig. 4.3-2. Correlation of salinity between sensor data and bottle data.

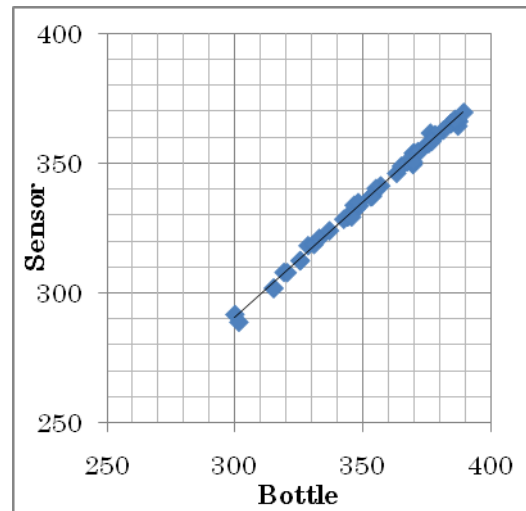

Fig. 4.3-3. Correlation of dissolved oxygen between sensor data and bottle data.

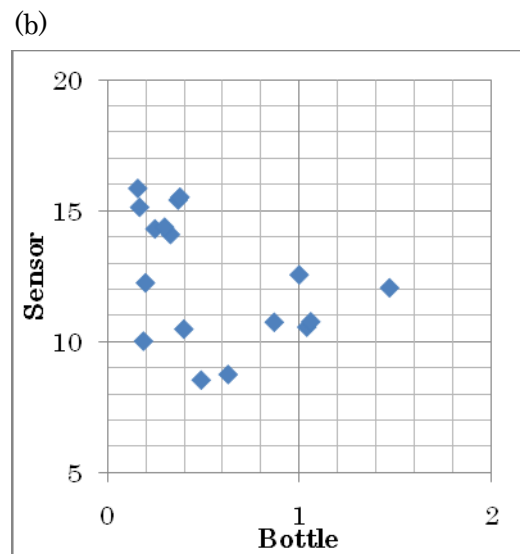
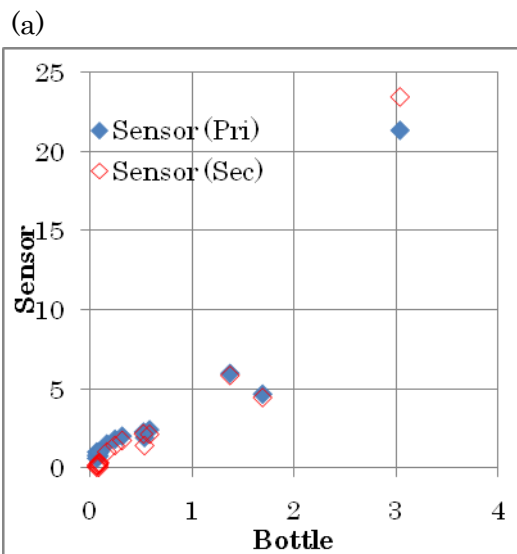

Fig. 4.3-4. Correlation of fluorescence between sensor data and bottle data.

(a) Fluorometer, C3 data and (b) Fluorometer, 10-AU data.

4.4. pCO₂

(1) Personnel

Shigeto NISHINO (JAMSTEC) : Principal Investigator

Fuyuki SHIBATA (MWJ)

Yoshiko ISHIKAWA (MWJ)

Hatsumi AOYAMA (MWJ)

(2) Objective

Magnitude of the anticipated global warming depends on the levels of CO₂ in the atmosphere, however, the ocean have an important role because one third of the 6 Gt of carbon emitted into the atmosphere by human activities each year is absorbed into the ocean. Hence, the clarification of both mechanism and capacity of oceanic CO₂ uptake are urgent tasks. Furthermore, in recent years, sea ice in the Arctic Ocean melts in vast area in summer relative to decades ago. The CO₂ flux between atmosphere and ocean directly depends on their CO₂ partial pressure (pCO₂) difference, therefore, the recent Arctic summer open ocean is considered to play an important role for global carbon cycle. We here report onboard measurements of pCO₂ during MR10-05 cruise.

(3) Parameter

Atmospheric and oceanic CO₂ partial pressure (pCO₂)

(4) Instruments and Method

Concentrations of atmospheric and oceanic CO₂ were measured onboard during the cruise using an automated system with a non-dispersive infrared gas analyzer (NDIR; MLT 3T-IR). Four standard gases, atmospheric air and CO₂ equilibrated air with surface seawater were analyzed every one and half hour. The CO₂ in air with their concentrations of 249, 301, 351 and 401 ppmv were used for the standard gases.

Atmospheric air was introduced from the bow of the ship (approx.30m above the sea level) into the analyzer through 1) a mass flow controller with its flow rate of 0.5 L min⁻¹, 2) a electric cooling unit, 3) a perma-pure dryer (GL Sciences Inc.) and 4) a chemical desiccant (Mg(ClO₄)₂).

Oceanic CO₂ concentration was measured by analyzing the CO₂ equilibrated air with surface seawater. Seawater pumped up from approx. 4.5 m below the sea

surface was continuously showered into an equilibrator at a rate of 5 L min^{-1} and the CO_2 concentration in the equilibrator was equal to that of surface seawater within 6 minutes. The CO_2 equilibrated air was then introduced into the analyzer by another pump with its flow rate of $0.7 - 0.8 \text{ L min}^{-1}$ through 1) two electronic cooling units, 2) the perma-pure dryer and 3) the chemical desiccant.

(5) Observation log

The track observed pCO_2 is shown in Fig. 4.4-1.

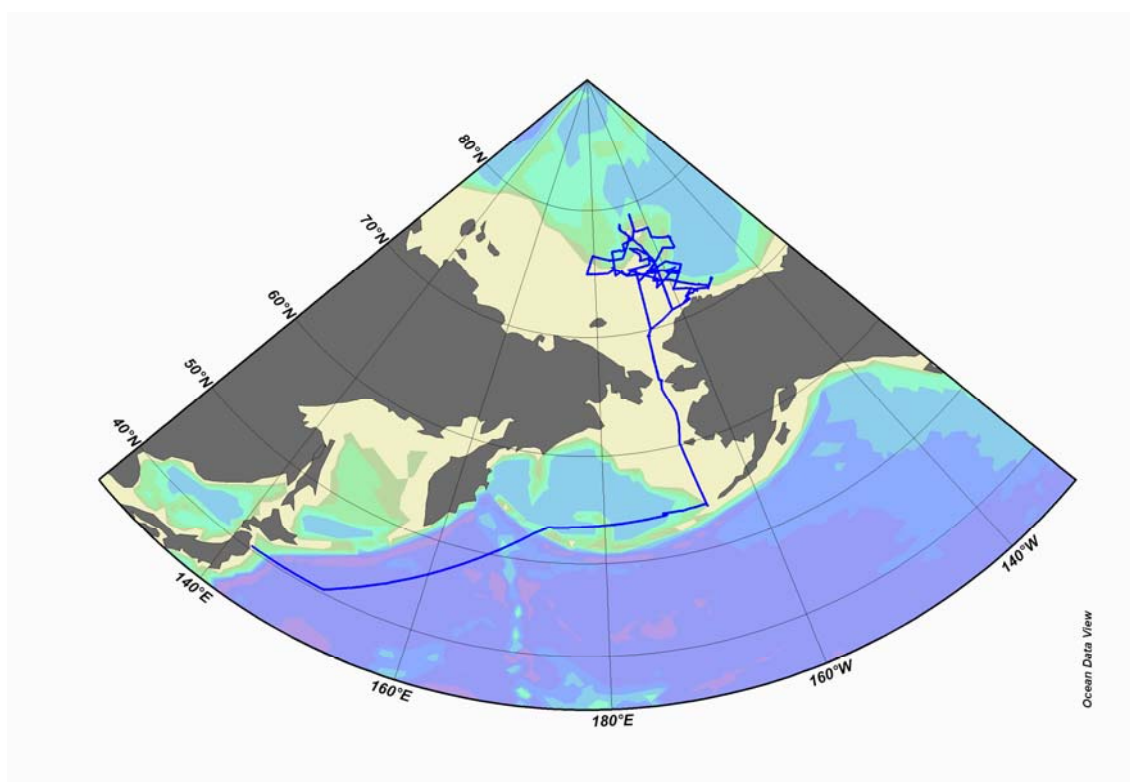

Fig. 4.4-1. Observation map.

(6) Results

Temporal variations of atmospheric and oceanic CO_2 concentration ($x\text{CO}_2$) are shown in Fig. 4.4-2.

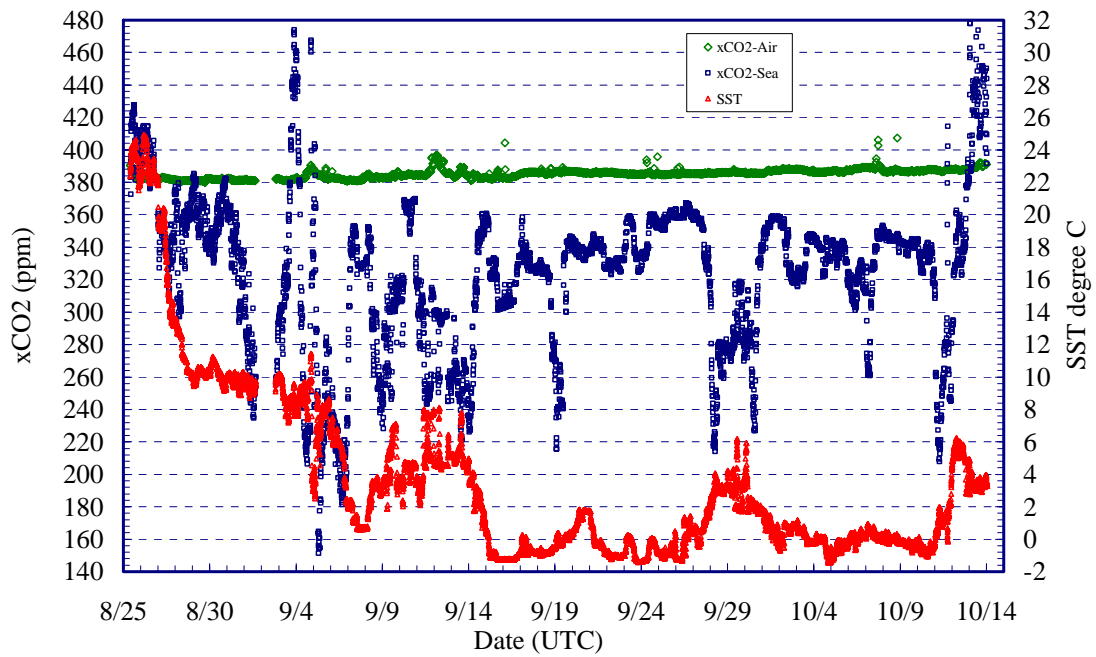

Fig. 4.4-2. Temporal variations of atmospheric and oceanic CO₂ concentration (xCO₂). Green dots represent atmosphere xCO₂ variation and blue is oceanic xCO₂. SST variation (red) is also shown.

(6) Date archives

These data obtained in this cruise will be submitted to the Data Management Office (DMO) of JAMSTEC, and will be opened to the public via "R/V Mirai Data Web Page" in JAMSTEC home page.

4.5. Dissolved Inorganic Carbon

(1) Personnel

Shigeto NISHINO (JAMSTEC) : Principal Investigator

Yoshiko ISHIKAWA (MWJ)

Hatsumi AOYAMA (MWJ)

(2) Objective

The Arctic Ocean has the feature that Dissolved Inorganic Carbon(DIC) concentration is low, under the influence of inflow of a large amount of river water and dilution by sea ice melt water, and high biological productivity. Recently, surface undersaturation of calcium carbonate was observed caused by sea ice dilution and we are anxious about its influences on growth of biota which forms shells of calcium carbonate. The percentage saturation of seawater in respect to calcium carbonate can be computed from DIC and TA(ref. section 4.6). We here report on-board measurements of DIC performed during the MR10-05 cruise.

(3) Parameters

Dissolved Inorganic Carbon, DIC

(4) Instruments and Methods

(4)-1 Seawater sampling

Seawater samples were collected by 12 L Niskin bottles and by a bucket at 70 stations. Seawater was then transferred into a 300ml glass bottle (SCHOTT DURAN) that was previously soaked in 5 % non-phosphoric acid detergent (pH13) solution at least 3 hours, and rinsed with fresh water for 5 times and Milli-Q deionized water for 3 times. A sampling tube was connected to the Niskin bottle when the sampling was carried out. The glass bottles were filled from the bottom, without rinsing, and were overflowed for 20 seconds. They were sealed using the 29 mm polyethylene inner lids with care not to leave any bubbles in the bottle. After collecting the samples on the deck, the glass bottles were moved to the lab to be measured. Prior to the analysis, 3 ml of the sample (1 % of the bottle volume) was removed from the glass bottle in order to make a headspace. The samples were then poisoned with 100 μ l of over saturated solution of mercury chloride within one hour after the sampling. After poisoning, the samples were sealed using the 31.9 mm polyethylene inner lids and stored in a refrigerator at approximately 5degC until being analyzed.

(4)-2 Seawater analysis

Measurements of DIC were made with total CO₂ measuring system (systems A; Nippon ANS,

Inc.). The system comprise of seawater dispensing system, a CO₂ extraction system and a coulometer (Model seacat2000, Nippon ANS, Inc.)

The seawater dispensing system has an auto-sampler (6 ports), which takes seawater from a glass bottle to a pipette of nominal 21ml volume by PC control. The pipette was kept at 20 ± 0.05 degC by a water jacket, in which water is circulated from a thermostatic water bath (RTE 10, Thermo) set at 20 degC.

DIC dissolved in a seawater sample is extracted in a stripping chamber of the CO₂ extraction system by adding phosphoric acid (10 % v/v). The stripping chamber is made approx. 20 cm long and has a fine frit at the bottom. A constant volume of acid is added to the stripping chamber from its bottom by pressurizing an acid bottle with nitrogen gas (99.9999 %). A seawater sample kept in a constant volume pipette is then introduced to the stripping chamber by the same method. Nitrogen gas is bubbled through a fine frit at the bottom of the stripping chamber to make the reaction well. The stripped CO₂ is carried by the nitrogen gas (flow rates of 140 ml min⁻¹) to the coulometer through a dehydrating module consists of two electric dehumidifiers (kept at 0.5 degC) and a chemical desiccant (Mg(ClO₄)₂).

The measurement sequence such as 1.8 % CO₂ gas in a nitrogen base, system blank (phosphoric acid blank), and seawater samples (6 samples) was programmed to repeat. The measurement of 1.8 % CO₂ gas was made to monitor response of coulometer solutions (from UIC, Inc.).

(5) Observation log

The sampling stations for DIC are shown in Fig. 4.5-1.

(6) Preliminary results

During the cruise, 1260 samples were analyzed for DIC. A few replicate samples were taken at most of stations and the difference between each pair of analyses was plotted on a range control chart (see Fig. 4.5-2). The average of the differences was 0.91 $\mu\text{mol kg}^{-1}$ (n=174). The standard deviation was 0.94 $\mu\text{mol kg}^{-1}$, which indicates that the analysis was accurate enough according to the Guide to best practices for ocean CO₂ measurements (Dickson et al., 2007).

(7) Data archives

These data obtained in this cruise will be submitted to the Data Management Office (DMO) of JAMSTEC, and will opened to the public via “R/V Mirai Data Web Page” in JAMSTEC home page.

(8) Reference

Dickson, A. G., Sabine, C. L. & Christian, J. R. (2007), Guide to best practices for ocean CO₂

measurements; PICES Special Publication 3, 199pp.

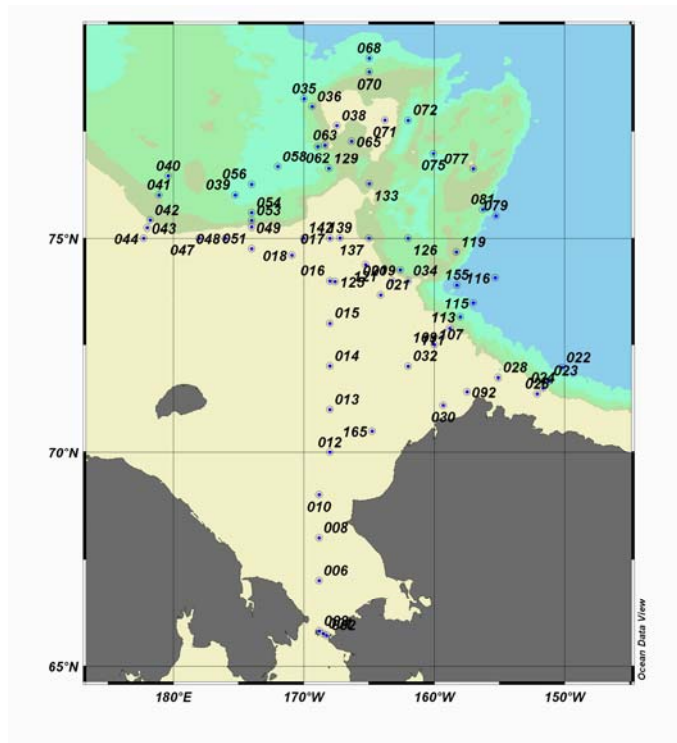

Fig. 4.5-1. Map of sampling stations.

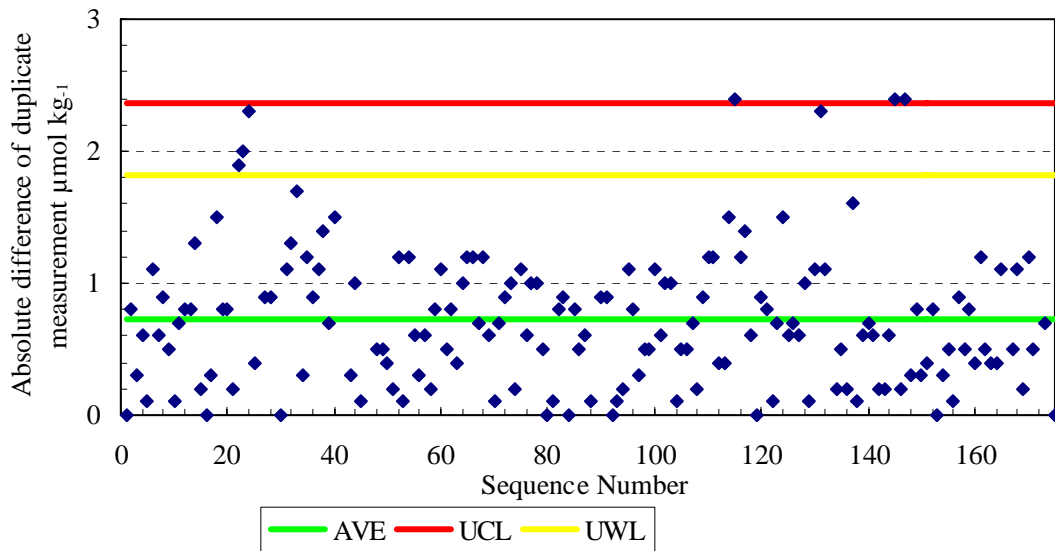

Fig. 4.5-2. Range control chart of the absolute differences of replicate measurements carried out in the analysis of DIC during the MR10-05 cruise. UCL and UWL represents the upper control limit ($\text{UCL}=\text{AVE}\times 3.267$) and upper warning limit ($\text{UWL}=\text{AVE}\times 2.512$), respectively.

4.6. Total Alkalinity, TA

(1) Personnel

Shigeto NISHINO (JAMSTEC): Principal Investigator

Minoru KAMATA (MWJ)

Ayaka HATSUYAMA (MWJ)

(2) Objective

The Arctic Ocean receives a large amount of river water from the surrounding continents. Since river water carries not only freshwater but also carbon, nutrients, contaminants etc., changes in distribution and residence time of river water in the Arctic Ocean may affect regional and global climate, productivity and human health. In order to trace river water in the Arctic Ocean, we have analyzed total alkalinity (TA) of seawater, with which river runoff (TA $\sim 1000 \mu\text{mol kg}^{-1}$) can be distinguished from sea ice meltwater (TA $\sim 260 \mu\text{mol kg}^{-1}$). Moreover, by using TA with oxygen isotope ratio (ref. section 4.7), the source of river water can be further distinguished between North American rivers (TA $\sim 1600 \mu\text{mol kg}^{-1}$) and Eurasian rivers (TA $\sim 800 \mu\text{mol kg}^{-1}$). We here report on-board measurements of total alkalinity performed during the MR10-05 cruise.

(3) Parameters

Total Alkalinity, TA

(4) Instruments and Methods

a. Seawater sampling

Seawater samples were collected in 12 L Niskin bottles mounted on the CTD-rosette system. A sampling silicone rubber with PFA tip was connected to the Niskin bottle when the sampling was carried out. The 125 ml borosilicate glass bottles (SHOTT DURAN) were filled from the bottom smoothly, without rinsing, and were overflowed for 2 times bottle volume (10 seconds) with care not to leave any bubbles in the bottle. These bottles were pre-washed by soaking in 5 % non-phosphoric acid detergent (pH = 13) for more than 3 hours and then rinsed 5 times with tap water and 3 times with Milli-Q deionized water. After collecting the samples on the deck, the bottles were carried into the lab and put in the water bath kept about 25° C for one hour before the measurement.

b. Seawater analysis

Measurement of alkalinity was made using a spectrophotometric system (Nippon ANS, Inc.) with a scheme of Yao and Byrne (1998). The sampled seawater in the glass bottle is transferred to a sample cell in the spectrophotometer (Carry 50 Scan, Varian) via dispensing unit. The length and volume of the cell are 8 cm and 13 ml, respectively, and its temperature is kept at 25° C in a thermostated compartment. The TA is calculated by measuring two sets of absorbance at three wavelengths (750, 616 and 444 nm). One is the absorbance of seawater sample before injecting an acid with indicator solution (bromocresol green sodium) and another is the one after the injection. For mixing the acid with indicator solution and the seawater sufficiently, they are circulated through the line by a peristaltic pump 7 and half minutes before the measurement.

The TA is calculated based on the following equation:

$$\begin{aligned} \text{pH}_T = & 4.2699 + 0.002578 * (35 - S) \\ & + \log ((R(25) - 0.00131) / (2.3148 - 0.1299 * R(25))) \\ & - \log (1 - 0.001005 * S), \end{aligned} \quad (1)$$

$$\begin{aligned} A_T = & (N_A * V_A - 10^{-\text{pH}_T} * \text{DensSW}(T, S) * (V_S + V_A)) \\ & * (\text{DensSW}(T, S) * V_S)^{-1}, \end{aligned} \quad (2)$$

where R(25) represents the difference of absorbance at 616 and 444 nm between before and after the injection. The absorbance of wavelength at 750 nm is used to subtract the variation of absorbance caused by the system. DensSW (T, S) is the density of seawater at temperature (T) and salinity (S), N_A the concentration of the added acid, V_A and V_S the volume of added acid and seawater, respectively.

To keep the high analysis precision, some treatments were carried out during the cruise. The acid with indicator solution stored in 1 L DURAN bottle is kept in a bath with its temperature of 25° C, and about 10 ml of it is discarded at first before the batch of measurement. For mixing the seawater and the acid with indicator solution sufficiently, TYGON tube used on the peristaltic pump was periodically renewed. Absorbance measurements were done 10 times during each analysis, and the stable last five and three values are averaged and used for above listed calculation for before and after the injection, respectively.

(5) Observation log

Seawater samples were collected at 70 stations (See Fig. 4.6-1).

(6) Preliminary results

A few duplicate samples were taken at most of stations and the difference between each pair of analyses was plotted on a range control chart (Fig. 4.6-2). The average of the difference was $0.4 \mu\text{mol kg}^{-1}$ ($n = 178$ pair) with its standard deviation of $0.4 \mu\text{mol kg}^{-1}$, which indicates that the analysis was accurate enough according to Guide to best practices for ocean CO_2 measurements (Dickson et al., 2007).

(7) Data Archive

These data obtained in this cruise will be submitted to the Data Management Office (DMO) of JAMSTEC, and will be opened to the public via “R/V Mirai Data Web Page” in JAMSTEC home page.

(8) References

Yao, W. and Byrne, R. H. (1998), Simplified seawater alkalinity analysis: Use of linear array spectrometers. *Deep-Sea Research Part I*, Vol. 45, 1383-1392.

Guide to best practices for ocean CO_2 measurements (2007); PICES Special Publication 3, 199pp. A. G. Dickson, C. L. Sabine & J. R. Christian, Eds.

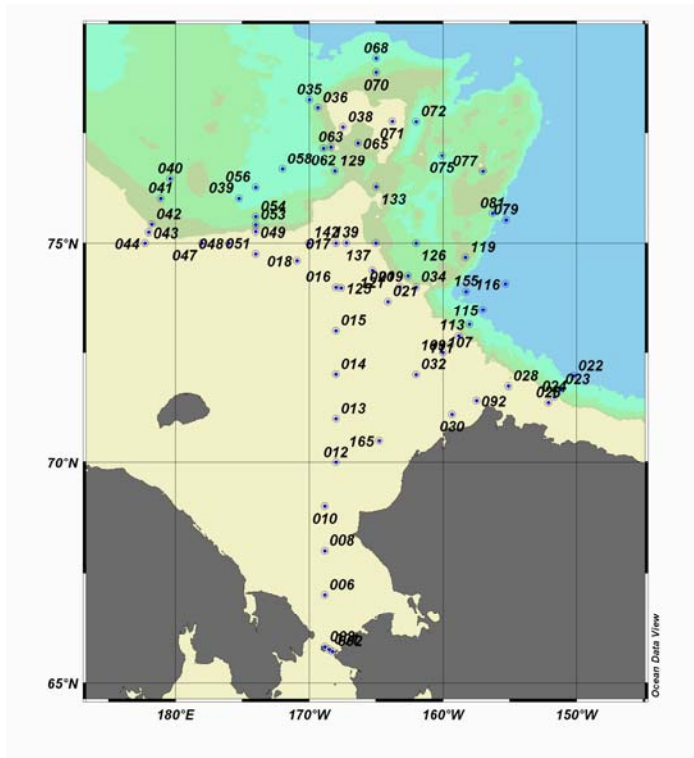

Fig. 4.6-1. Map of sampling stations.

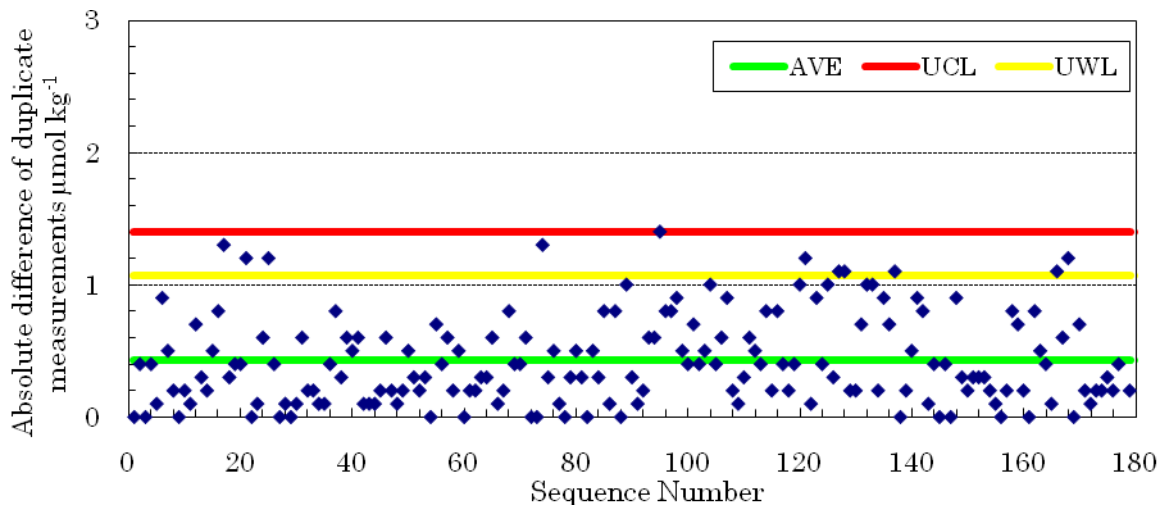

Fig. 4.6-2. Range control chart of the absolute differences of duplicate measurements carried out in the analysis of TA during this cruise. UCL and UWL represents the upper control limit ($\text{UCL}=\text{AVE}\times 3.267$) and upper warning limit ($\text{UWL}=\text{AVE}\times 2.512$), respectively.

4.7. Oxygen isotope ratio ($\delta^{18}\text{O}$)

(1) Personnel

Shigeto Nishino

(JAMSTEC): Principal Investigator

(2) Objectives

Oxygen isotope ratio ($\delta^{18}\text{O}$) of seawater is a tracer to distinguish the source of freshwater between sea ice meltwater and meteoric water (river runoff and precipitation). We have collected seawater samples for $\delta^{18}\text{O}$ analysis during the cruise. Results will be compared with previous observations observed during cruises of R/V Mirai in 2002, 2008, and 2009 in order to detect on-going changes in freshwater distributions in the Arctic Ocean under the recent conditions of warming and attendant increase in sea ice melt. Furthermore, a combination of $\delta^{18}\text{O}$ with total alkalinity (ref. Section 4.6) may provide additional information about the distribution of North American river runoff because, although American and Eurasian rivers have identical oxygen isotope ratios, the total alkalinity of American river water is higher than Eurasian river water.

(3) Parameter

Oxygen isotope ratio ($\delta^{18}\text{O}$)

(4) Instruments and methods

Seawater samples were collected in 12L Niskin bottles mounted on the CTD-rosette system and then transferred into 10 ml glass vials for $\delta^{18}\text{O}$ analysis. The sampling list is summarized in Table 4.7-1. Samples are stored in room temperature and will be analyzed at JAMSTEC. Results will be reported as a permil deviation of oxygen isotope ratio of the sample from that of international standard seawater (VSMOW):

$$\delta^{18}\text{O} = \left\{ \left(\frac{\text{H}_2^{18}\text{O}}{\text{H}_2^{16}\text{O}} \right)_{\text{sample}} - \left(\frac{\text{H}_2^{18}\text{O}}{\text{H}_2^{16}\text{O}} \right)_{\text{VSMOW}} \right\} / \left(\frac{\text{H}_2^{18}\text{O}}{\text{H}_2^{16}\text{O}} \right)_{\text{VSMOW}} \times 1000 \text{ [‰]}.$$

(5) Data archives

These data obtained in this cruise will be submitted to the Data Integration and Analysis Group (DIAG) of JAMSTEC, and will be opened to the public via “R/V Mirai Data Web Page” in JAMSTEC home page.

Table 4.7-1 Sampling list for $\delta^{18}\text{O}$

Sample #	Sta	Niskin #	Sample #	Sta	Niskin #	Sample #	Sta	Niskin #
1	001	0	51	010	22	101	016	23
2	001	1	52	010	23	102	016	24
3	001	1dup	53	010	24	103	016	24dup
4	001	21	54	010	24dup	104	017	0
5	001	22	55	012	0	105	017	1
6	001	23	56	012	1	106	017	1dup
7	001	24	57	012	1dup	107	017	16
8	001	24dup	58	012	21	108	017	17
9	002	1	59	012	22	109	017	18
10	002	1dup	60	012	23	110	017	19
11	002	21	61	012	24	111	017	20
12	002	22	62	012	24dup	112	017	20dup
13	002	23	63	013	0	113	017	21
14	002	24	64	013	1	114	017	22
15	002	24dup	65	013	1dup	115	017	23
16	003	1	66	013	21	116	017	24
17	003	1dup	67	013	22	117	017	24dup
18	003	21	68	013	23	118	018	0
19	003	22	69	013	24	119	018	1
20	003	23	70	013	24dup	120	018	1dup
21	003	24	71	014	0	121	018	12
22	003	24dup	72	014	1	122	018	13
23	006	0	73	014	1dup	123	018	14
24	006	1	74	014	21	124	018	15
25	006	1dup	75	014	25	125	018	16
26	006	21	76	014	23	126	018	17
27	006	22	77	014	24	127	018	18
28	006	23	78	014	24dup	128	018	18dup
29	006	24	79	015	0	129	018	19
30	006	24dup	80	015	1	130	018	20
31	007	0	81	015	1dup	131	018	21
32	007	1	82	015	20	132	018	22
33	007	1dup	83	015	20dup	133	018	22dup
34	007	21	84	015	21	134	019	0
35	007	22	85	015	22	135	019	1
36	007	23	86	015	23	136	019	1dup
37	007	24	87	015	24	137	019	6
38	007	24dup	88	015	24dup	138	019	7
39	008	0	89	016	0	139	019	8
40	008	1	90	016	1	140	019	9
41	008	1dup	91	016	1dup	141	019	10
42	008	21	92	016	15	142	019	11
43	008	22	93	016	16	143	019	12
44	008	23	94	016	17	144	019	13
45	008	24	95	016	18	145	019	14
46	008	24dup	96	016	19	146	019	15
47	010	0	97	016	20	147	019	16
48	010	1	98	016	20dup	148	019	17
49	010	1dup	99	016	21	149	019	18
50	010	21	100	016	22	150	019	19

Table 4.7-1 Sampling list for $\delta^{18}\text{O}$

Sample #	Sta	Niskin #	Sample #	Sta	Niskin #	Sample #	Sta	Niskin #
151	019	20	201	022	15	251	028	0
152	019	21	202	022	16	252	028	1
153	019	22	203	022	17	253	028	1dup
154	019	23	204	022	18	254	028	12
155	019	24	205	022	19	255	028	13
156	020	0	206	022	20	256	028	14
157	020	1	207	022	21	257	028	15
158	020	1dup	208	022	22	258	028	16
159	020	11	209	022	23	259	028	17
160	020	12	210	022	24	260	028	18
161	020	13	211	023	0	261	028	19
162	020	14	212	023	1	262	028	20
163	020	15	213	023	1dup	263	028	21
164	020	16	214	023	10	264	028	22
165	020	17	215	023	12	265	030	0
166	020	18	216	023	14	266	030	1
167	020	19	217	023	15	267	030	1dup
168	020	20	218	023	16	268	030	19
169	020	21	219	023	17	269	030	20
170	020	22	220	023	18	270	030	21
171	020	23	221	023	19	271	030	22
172	020	24	222	023	20	272	030	23
173	021	0	223	023	21	273	030	24
174	021	1	224	023	22	274	032	0
175	021	1dup	225	023	23	275	032	1
176	021	16	226	023	24	276	032	1dup
177	021	17	227	024	0	277	032	23
178	021	18	228	024	1	278	032	24
179	021	19	229	024	1dup	279	034	0
180	021	20	230	024	10	280	034	1
181	021	21	231	024	12	281	034	1dup
182	021	22	232	024	14	282	034	10
183	021	23	233	024	15	283	034	11
184	021	24	234	024	16	284	034	12
185	022	0	235	024	17	285	034	13
186	022	1	236	024	18	286	034	14
187	022	1dup	237	024	19	287	034	15
188	022	2	238	024	20	288	034	16
189	022	3	239	024	21	289	034	17
190	022	4	240	024	22	290	034	18
191	022	5	241	024	23	291	034	19
192	022	6	242	024	24	292	034	20
193	022	7	243	026	0	293	034	21
194	022	8	244	026	1	294	034	22
195	022	9	245	026	1dup	295	034	23
196	022	10	246	026	20	296	034	24
197	022	11	247	026	21	297	035	0
198	022	12	248	026	22	298	035	1
199	022	13	249	026	23	299	035	1dup
200	022	14	250	026	24	300	035	3

Table 4.7-1 Sampling list for $\delta^{18}\text{O}$

Sample #	Sta	Niskin #	Sample #	Sta	Niskin #	Sample #	Sta	Niskin #
301	035	4	351	038	18	401	040	22
302	035	5	352	038	19	402	040	23
303	035	6	353	038	20	403	040	24
304	035	7	354	038	21	404	041	0
305	035	8	355	038	22	405	041	1
306	035	9	356	038	23	406	041	1dup
307	035	10	357	038	24	407	041	10
308	035	11	358	039	0	408	041	11
309	035	12	359	039	1	409	041	12
310	035	13	360	039	1dup	410	041	13
311	035	14	361	039	4	411	041	14
312	035	15	362	039	5	412	041	15
313	035	16	363	039	6	413	041	16
314	035	17	364	039	7	414	041	17
315	035	18	365	039	8	415	041	18
316	035	19	366	039	9	416	041	19
317	035	20	367	039	10	417	041	20
318	035	21	368	039	11	418	041	21
319	035	22	369	039	12	419	041	22
320	035	23	370	039	13	420	041	23
321	035	24	371	039	14	421	041	24
322	036	0	372	039	15	422	042	0
323	036	1	373	039	16	423	042	1
324	036	1dup	374	039	17	424	042	1dup
325	036	10	375	039	18	425	042	10
326	036	11	376	039	19	426	042	11
327	036	12	377	039	20	427	042	12
328	036	13	378	039	21	428	042	13
329	036	14	379	039	22	429	042	14
330	036	15	380	039	23	430	042	15
331	036	16	381	039	24	431	042	16
332	036	17	382	040	0	432	042	17
333	036	18	383	040	1	433	042	18
334	036	19	384	040	1dup	434	042	19
335	036	20	385	040	6	435	042	20
336	036	21	386	040	7	436	042	21
337	036	22	387	040	8	437	042	22
338	036	23	388	040	9	438	043	0
339	036	24	389	040	10	439	043	1
340	038	0	390	040	11	440	043	1dup
341	038	1	391	040	12	441	043	10
342	038	1dup	392	040	13	442	043	11
343	038	10	393	040	14	443	043	12
344	038	11	394	040	15	444	043	13
345	038	12	395	040	16	445	043	14
346	038	13	396	040	17	446	043	15
347	038	14	397	040	18	447	043	16
348	038	15	398	040	19	448	043	17
349	038	16	399	040	20	449	043	18
350	038	17	400	040	21	450	043	19

Table 4.7-1 Sampling list for $\delta^{18}\text{O}$

Sample #	Sta	Niskin #	Sample #	Sta	Niskin #	Sample #	Sta	Niskin #
451	043	20	501	049	19	551	054	19
452	043	21	502	049	20	552	054	20
453	043	22	503	049	21	553	054	21
454	043	23	504	049	22	554	054	22
455	043	24	505	051	0	555	054	23
456	043	27	506	051	1	556	054	24
457	044	0	507	051	1dup	557	056	0
458	044	1	508	051	12	558	056	1
459	044	1dup	509	051	13	559	056	1dup
460	044	14	510	051	14	560	056	10
461	044	15	511	051	15	561	056	11
462	044	16	512	051	16	562	056	12
463	044	17	513	051	17	563	056	13
464	044	18	514	051	18	564	056	14
465	044	19	515	051	19	565	056	15
466	044	20	516	051	20	566	056	16
467	044	21	517	051	21	567	056	17
468	044	22	518	051	22	568	056	18
469	044	23	519	051	23	569	056	19
470	044	24	520	051	24	570	056	20
471	047	0	521	053	0	571	056	21
472	047	1	522	053	1	572	056	22
473	047	1dup	523	053	1dup	573	058	0
474	047	10	524	053	10	574	058	1
475	047	11	525	053	11	575	058	1dup
476	047	12	526	053	12	576	058	10
477	047	13	527	053	13	577	058	11
478	047	14	528	053	14	578	058	12
479	047	15	529	053	15	579	058	13
480	047	16	530	053	16	580	058	14
481	047	17	531	053	17	581	058	15
482	047	18	532	053	18	582	058	16
483	047	19	533	053	19	583	058	17
484	047	20	534	053	20	584	058	18
485	047	21	535	053	21	585	058	19
486	047	22	536	053	22	586	058	20
487	047	23	537	053	23	587	058	21
488	047	24	538	053	24	588	058	22
489	049	0	539	054	0	589	058	23
490	049	1	540	054	1	590	058	24
491	049	1dup	541	054	1dup	591	062	0
492	049	10	542	054	10	592	062	1
493	049	11	543	054	11	593	062	1dup
494	049	12	544	054	12	594	062	10
495	049	13	545	054	13	595	062	11
496	049	14	546	054	14	596	062	12
497	049	15	547	054	15	597	062	13
498	049	16	548	054	16	598	062	14
499	049	17	549	054	17	599	062	15
500	049	18	550	054	18	600	062	16

Table 4.7-1 Sampling list for $\delta^{18}\text{O}$

Sample #	Sta	Niskin #	Sample #	Sta	Niskin #	Sample #	Sta	Niskin #
601	062	17	651	071	13	701	075	20
602	062	18	652	071	14	702	075	21
603	062	19	653	071	15	703	075	22
604	062	20	654	071	16	704	075	23
605	062	21	655	071	17	705	075	24
606	062	22	656	071	18	706	077	0
607	062	23	657	071	19	707	077	1
608	062	24	658	071	20	708	077	1dup
609	065	0	659	071	21	709	077	10
610	065	1	660	071	22	710	077	11
611	065	1dup	661	071	23	711	077	12
612	065	10	662	071	24	712	077	13
613	065	11	663	072	0	713	077	14
614	065	12	664	072	1	714	077	15
615	065	13	665	072	1dup	715	077	16
616	065	14	666	072	3	716	077	17
617	065	15	667	072	4	717	077	18
618	065	16	668	072	5	718	077	19
619	065	17	669	072	6	719	077	20
620	065	18	670	072	7	720	077	21
621	065	19	671	072	8	721	077	22
622	065	20	672	072	9	722	077	23
623	065	21	673	072	10	723	077	24
624	065	22	674	072	11	724	079	0
625	065	23	675	072	12	725	079	1
626	065	24	676	072	13	726	079	1dup
627	068	0	677	072	14	727	079	2
628	068	1	678	072	15	728	079	3
629	068	1dup	679	072	16	729	079	5
630	068	4	680	072	17	730	079	6
631	068	6	681	072	18	731	079	8
632	068	8	682	072	19	732	079	9
633	068	9	683	072	20	733	079	10
634	068	10	684	072	21	734	079	11
635	068	11	685	072	22	735	079	12
636	068	12	686	072	23	736	079	13
637	068	13	687	072	24	737	079	14
638	068	14	688	075	0	738	079	15
639	068	15	689	075	1	739	079	16
640	068	16	690	075	1dup	740	079	17
641	068	17	691	075	10	741	079	18
642	068	18	692	075	11	742	079	19
643	068	19	693	075	12	743	079	20
644	068	20	694	075	13	744	079	21
645	068	21	695	075	14	745	079	22
646	068	22	696	075	15	746	079	23
647	071	0	697	075	16	747	079	24
648	071	1	698	075	17	748	079	26
649	071	1dup	699	075	18	749	079	4or7-1
650	071	12	700	075	19	750	079	4or7-2

Table 4.7-1 Sampling list for $\delta^{18}\text{O}$

Sample #	Sta	Niskin #	Sample #	Sta	Niskin #	Sample #	Sta	Niskin #
751	081	0	801	113	10	851	116	16
752	081	1	802	113	11	852	116	17
753	081	1dup	803	113	12	853	116	18
754	081	10	804	113	13	854	116	19
755	081	11	805	113	14	855	116	20
756	081	12	806	113	15	856	116	21
757	081	13	807	113	16	857	116	22
758	081	14	808	113	17	858	116	23
759	081	15	809	113	18	859	116	24
760	081	16	810	113	19	860	119	0
761	081	30	811	113	20	861	119	1
762	081	18	812	113	21	862	119	1dup
763	081	19	813	113	22	863	119	10
764	081	20	814	113	23	864	119	11
765	081	21	815	113	24	865	119	12
766	081	22	816	115	0	866	119	13
767	107	0	817	115	1	867	119	14
768	107	1	818	115	1dup	868	119	15
769	107	1dup	819	115	2	869	119	16
770	107	21	820	115	3	870	119	17
771	107	22	821	115	4	871	119	18
772	107	23	822	115	5	872	119	19
773	107	24	823	115	6	873	119	20
774	109	0	824	115	7	874	119	21
775	109	1	825	115	8	875	119	22
776	109	1dup	826	115	9	876	119	23
777	109	20	827	115	10	877	119	24
778	109	21	828	115	11	878	121	0
779	109	22	829	115	12	879	121	1
780	109	23	830	115	13	880	121	1dup
781	109	24	831	115	14	881	121	10
782	111	0	832	115	15	882	121	11
783	111	1	833	115	16	883	121	12
784	111	1dup	834	115	17	884	121	13
785	111	10	835	115	18	885	121	14
786	111	11	836	115	19	886	121	15
787	111	12	837	115	20	887	121	16
788	111	13	838	115	21	888	121	17
789	111	14	839	115	22	889	121	18
790	111	15	840	115	23	890	121	19
791	111	16	841	115	24	891	121	20
792	111	17	842	116	0	892	121	21
793	111	18	843	116	1	893	121	22
794	111	19	844	116	1dup	894	121	23
795	111	20	845	116	10	895	121	24
796	111	21	846	116	11	896	125	0
797	111	22	847	116	12	897	125	1
798	113	0	848	116	13	898	125	15
799	113	1	849	116	14	899	125	16
800	113	1dup	850	116	15	900	125	17

Sample #	Sta	Niskin #	Sample #	Sta	Niskin #	Sample #	Sta	Niskin #
901	125	18	951	133	17			
902	125	19	952	133	18			
903	125	20	953	133	19			
904	125	21	954	133	20			
905	125	22	955	133	21			
906	125	23	956	133	22			
907	125	24	957	133	23			
908	126	0	958	133	24			
909	126	1	959	139	0			
910	126	1dup	960	139	1			
911	126	10	961	139	1dup			
912	126	11	962	139	13			
913	126	12	963	139	14			
914	126	13	964	139	15			
915	126	14	965	139	16			
916	126	15	966	139	17			
917	126	16	967	139	18			
918	126	17	968	139	19			
919	126	18	969	139	20			
920	126	19	970	139	21			
921	126	20	971	139	22			
922	126	21	972	139	23			
923	126	22	973	139	24			
924	129	0	974	142	0			
925	129	1	975	142	1			
926	129	1dup	976	142	1dup			
927	129	10	977	142	13			
928	129	11	978	142	14			
929	129	12	979	142	15			
930	129	13	980	142	16			
931	129	14	981	142	17			
932	129	15	982	142	18			
933	129	16	983	142	19			
934	129	17	984	142	20			
935	129	18	985	142	21			
936	129	19	986	142	22			
937	129	20	987	142	23			
938	129	21	988	142	24			
939	129	22	989	155	1			
940	129	23	990	155	4			
941	129	24	991	155	20			
942	133	0	992	155	22			
943	133	1	993	155	24			
944	133	1dup						
945	133	10						
946	133	12						
947	133	13						
948	133	14						
949	133	15						
950	133	16						

4.8. Chlorophyll *a* measurements of total and size-fractionated phytoplankton

(1) Personnel

Shigeto Nishino	(JAMSTEC) : Principal Investigator
Jonaotaro Onodera	(JAMSTEC)
Manami Satoh	(Tsukuba University)
Amane Fujiwara	(Hokkaido University)
Masanori Enoki	(MWJ) : Operation Leader
Masahiro Orui	(MWJ)

(2) Objective

Phytoplankton distributes in various species and sizes in the ocean. Phytoplankton species are roughly characterized by the cell size. The object of this study is to investigate the vertical and horizontal distributions of phytoplankton in the Arctic Ocean by using the size-fractionated filtration method.

(3) Parameters

Total chlorophyll *a*
Size-fractionated chlorophyll *a*

(4) Instruments and methods

We collected samples for total chlorophyll *a* (chl-*a*) from 13 depths between the surface and 200 m during routine casts. In some routine casts, we also collected samples for size-fractionated chl-*a* from 9 depths including a chl-*a* maximum depth, which was determined by a fluorometer (Seapoint Sensors, Inc.) attached to the CTD system. Furthermore, we collected samples for total chl-*a* and size-fractionated chl-*a* from 14 depths within the euphotic layer and the layer below down to 200 m during the casts where the primary productivity measurements were performed. The euphotic layer was determined by a downward irradiance sensor for the experiments of primary productivity, and the sampling depths were determined as light intensities of 50, 25, 10, 5, 2.5, 1 and 0.5% for the surface incident irradiance.

Water samples for total chl-*a* were vacuum-filtrated (<0.02MPa) through 25mm-diameter Whatman GF/F filter. Water samples for size-fractionated chl-*a* were sequentially vacuum-filtrated (<0.02MPa) through the three types of 47mm-diameter nuclepore filters (pore size of 10.0 μ m, 5.0 μ m and 2.0 μ m) and the 25mm-diameter Whatman GF/F filter. Phytoplankton pigments retained on the filters were

immediately extracted in a polypropylene tube with 7 ml of N,N-dimethylformamide. The tubes were stored at -20°C under the dark condition to extract chl-*a* for 24 hours or more.

Fluorescences of each sample were measured by Turner Design fluorometer (10-AU-005), which was calibrated against a pure chl-*a* (Sigma chemical Co.). We applied fluorometric determination for the samples of chl-*a*: “Non-acidification method” (Welschmeyer, 1994). Analytical conditions of this method were listed in Table 4.8-1.

(5) Results

Samples for total and size-fractionated chl-*a* were collected at 78 and 36 stations, respectively (See Fig. 4.8-1). The numbers of samples for total and size-fractionated chl-*a* were 978 and 1356, respectively.

The analytical precision of total chl-*a* is 3.5% ($n = 146$).

(6) Data archives

These data obtained in this cruise will be submitted to the Data Management Office (DMO) of JAMSTEC, and will be opened to the public via “R/V Mirai Data Web Page” in JAMSTEC home page.

(7) Reference

Welschmeyer, N. A. (1994): Fluorometric analysis of chlorophyll *a* in the presence of chlorophyll *b* and pheopigments. *Limnol. Oceanogr.*, 39, 1985–1992.

Table 4.8-1. Analytical conditions of non-acidification method for chlorophyll *a* with Turner Design fluorometer (10-AU-005)

	Non-acidification method
Excitation filter (nm)	436
Emission filter (nm)	680
Lamp	Blue F4T5,B2/BP

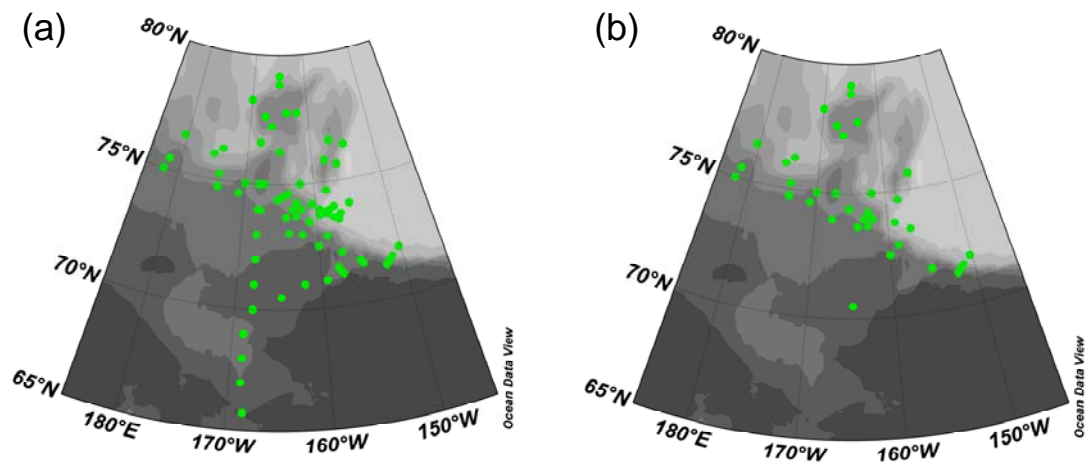

Fig. 4.8-1. Maps of stations for (a) total and (b) size-fractionated chlorophyll *a* measurements.

4.9. Primary, new and regenerated productions

(1) Personnel

Shigeto Nishino	(JAMSTEC): Principal Investigator
Toru Hirawake	(Hokkaido University)
Amane Fujiwara	(Hokkaido University)
Miyo Ikeda	(MWJ): Operation Leader
Kanako Yoshida	(MWJ)

(2) Objectives

Primary production was measured to estimate underwater photosynthesis by phytoplankton in the Arctic Ocean. New and regenerated productions were measured to examine biological activities associated with nutrient and chlorophyll *a* distributions and light conditions, especially focused on how the primary production is sustained by nitrate supplied from deeper layers or ammonium regenerated from organisms.

(3) Parameters

Primary production
New production
Regenerated production

(4) Instruments and methods

a. Instruments

Stable isotope analyzer

ANCA-SL SYSTEM by Europa Scientific Ltd.; now SerCon Ltd.

Software

ANCA Ver.3.6

b. Methods

Primary production was measured at 10 stations (Sts. 018, 028, 042, 049, 056, 068, 081, 111, 126 and 165), and new and regenerated productions were measured at 8 stations (Sts. 018, 028, 042, 049, 056, 068, 081, and 111) by simulated *in situ* incubation method (See Fig. 4.9-1 and Table 4.9-1). We sampled seawater using light-blocking and acid-treatment bottles and tubes connected to the Niskin bottles, which are derived from 7 or 8 optical depths, 100%, 50% 25%, 10%, 5%, 2.5%, 1% and 0.5% of surface irradiance.

After sampling, in a dark room seawater was dispensed into 1 L Nalgene polycarbonate bottles for incubation. The Nalgene bottles were used after acid treatment. These seawater samples were inoculated with labeled carbon substrate ($\text{NaH}^{13}\text{CO}_3$) for the measurements of primary production, and labeled nitrate (K^{15}NO_3) and ammonium ($^{15}\text{NH}_4\text{Cl}$) substrates for the measurements of new and regenerated productions. The concentration of labeled carbon ($\text{NaH}^{13}\text{CO}_3$) was 200 μM that was ca. 10 % enrichment to the total inorganic carbon in the ambient water. The concentrations of labeled nitrate (K^{15}NO_3) and ammonium ($^{15}\text{NH}_4\text{Cl}$) were 0.05 μM , except for the deepest layer (0.5% of surface irradiance) where the labeled nitrate concentration was 0.5 μM . (Only at St. 018, the first station for the measurements, the concentrations of labeled nitrate and ammonium were in the ranges from 0.05 to 1 μM and 0.05 to 0.1 μM , respectively, on a trial basis.) The bottles were placed into incubators with neutral density filters corresponding to light levels at the seawater sampling depths. Incubations using dark bottles were also conducted at each light level.

Samples for the measurements of primary production at Sts. 126 and 165 were incubated in a bath on the deck for 24 hours. On the other hand, samples for the measurements of new and regenerated productions at the rest of the stations, where primary productions were also measured, were incubated in the bath on the deck for 3 hours. At the end of the incubation period, samples were filtered through glass fiber filters (Whatman GF/F 25mm, pre-combusted under 450 degC over 6 hours). The filters were kept to freeze -20 degC until measurements. Before the measurements, the filters were oven-dried at 45 degC for at least 20 hours and treated with hydrochloric acid to remove the inorganic carbon. The measurements were performed on board the ship using a stable isotope analyzer (ANCA-NT, Europa Scientific Ltd.; now SerCon Ltd.).

(5) Station list

Table 4.9-1 shows a station list including optical depths, incubation times, and measured parameters with or without zero time (natural abundance) measurements.

(6) Data archives

These data obtained in this cruise will be submitted to the Data Management Office (DMO) of JAMSTEC, and will be opened to the public via “R/V Mirai Data Web Page” in JAMSTEC home page.

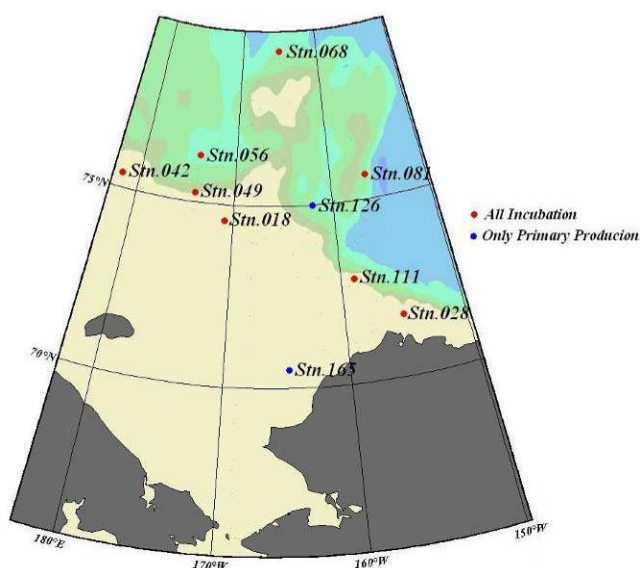

Fig. 4.9-1. Map of stations with station numbers for the measurements of new and regenerated productions with primary production (red dots) and primary production alone (blue dots).

Table 4.9-1. List of stations, optical depths, incubation times, and measured parameters with or without zero time (natural abundance) measurements

Stations	Optical Depths (%)	Incubation time (hrs)	Primary Production	New and regenerated production
018	0.5, 1, 2.5, 5, 10, 25, 100	3	x&0	x&0
028	0.5, 1, 2.5, 5, 10, 25, 100	3	x	x
042	0.5, 1, 2.5, 5, 10, 25, 100	3	x&0	x&0
049	0.5, 1, 2.5, 5, 10, 25, 100	3	x	x
056	0.5, 1, 2.5, 5, 10, 25, 100	3	x	x
068	0.5, 1, 2.5, 5, 10, 25, 100	3	x&0	x&0
081	0.5, 1, 2.5, 5, 10, 25, 100	3	x	x
111	0.5, 1, 2.5, 5, 10, 25, 100	3	x&0	x&0
126	0.5, 1, 2.5, 5, 10, 25, 50, 100	24	x&0	
165	1, 2.5, 5, 10, 25, 50, 100	24	x&0	

x: measurements without zero time

x&0: measurements with zero time

4.10. Bio-optical Observation

(1) Personnel

Toru Hirawake (P.I.) Hokkaido University (non-boarding)

Amane Fujiwara Hokkaido University

(2) Objectives

Objectives of these observations are (1) to investigate how phytoplankton biomass and community structures distribute due to the distribution of water mass and (2) to develop and evaluate an ocean color algorithm to estimate algal size using optical properties of seawater. Results from these investigations will be applied to satellite remote sensing and used to clarify the responses of phytoplankton to the recent climate change in the western Arctic Ocean.

(3) Parameters

A) Underwater spectral irradiance and radiance (PRR-800/810)

B) *In-situ* backscattering coefficients (HydroScat-6)

C) Light absorption coefficients of particles and colored dissolved organic materials (CDOM)

D) Phytoplankton pigments (detected by HPLC)

E) Copepods grazing rate (see details in Section 14.14)

(4) Instruments and methods

Bio-optical measurements were carried out at 31 stations (Figure 4.10-1). Most of the PRR800/810 observations were performed at 3 hours before/after noon.

A) PRR-800/810

Underwater spectral downwelling irradiance $E_d(\lambda, z)$ ($\mu\text{W cm}^{-2}\text{nm}^{-1}$) and upwelling radiance $L_u(\lambda, z)$ ($\mu\text{W cm}^{-2}\text{nm}^{-1}\text{sr}^{-1}$) at 17 wavelength over 380-765 nm were measured with a spectroradiometer PRR-800 (Biospherical Instrument Inc.). The PRR-800 was deployed in free-fall made up to 80-120 m deep distancing from the stern of ship to avoid her shadow. Incident downwelling irradiance to sea surface $E_d(\lambda, 0^+)$ was monitored by reference spectroradiometer, PRR-810 (Biospherical Instrument Inc.) with same

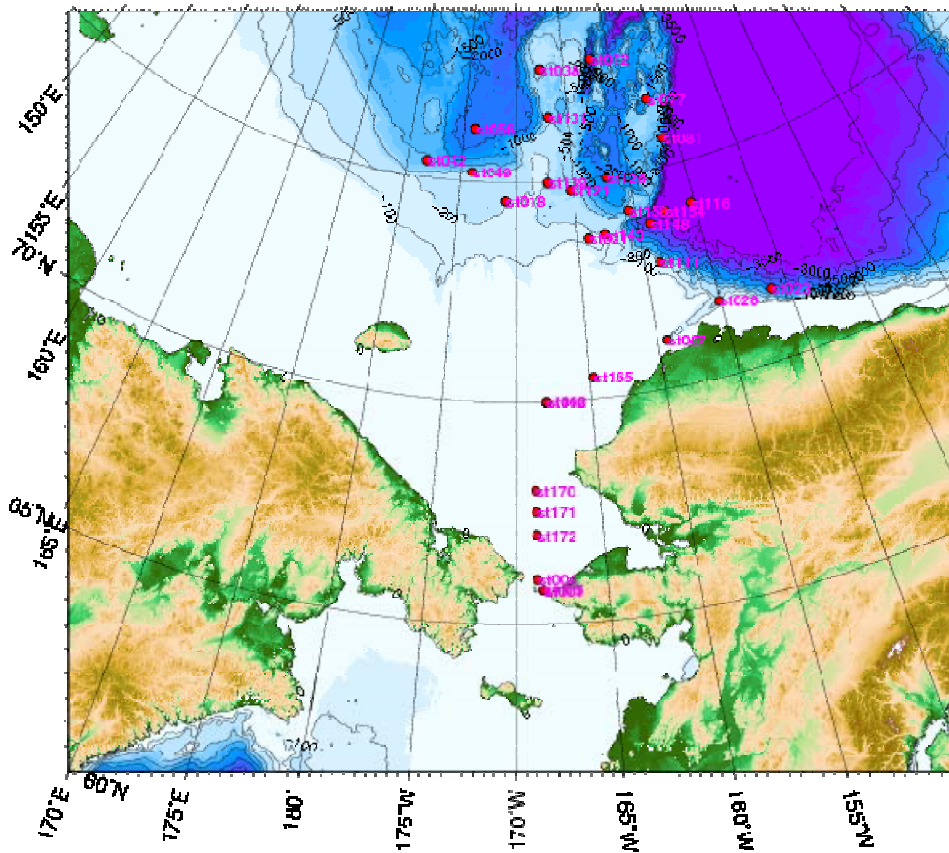

Figure 4.10-1. Map of bio-optical sampling stations

specification with PRR-800. After each deployment of the instrument, dark values were recorded for about 30 seconds.

B) HydroScat-6

In-situ volume scattering function at 140° angle of 6 wavelengths (420, 442, 488, 510, 550 and 676 nm) to determine backscattering coefficient of light $b_{bp}(\lambda)$ and fluorescence at 2 wavelengths (510 and 676 nm) were measured with a backscattering sensor – fluorometer HydroScat-6 (HOBI Labs). It is deployed up to 200 m deep.

C) Light absorption coefficients of particles and colored dissolved organic materials (CDOM)

Seawater samples for absorption coefficients measurement were collected from

the sea surface and fixed depths (10, 20, 35, 50 and 75 m) or depths corresponding to 25%, 10%, 5%, 2.5% and 1% of incident PAR using Niskin-X bottles on a CTD/Rosset Multi Sampler (Sea-Bird Electronics Inc.). For measurements of spectral absorption coefficient of particles, particles in 1-4 L of water sample were concentrated on a glass fiber filter (Whatman GF/F, ϕ 25 mm). Optical density (OD) of particles on the filter pad was measured with a spectrophotometer, MPS-2400 (Shimadzu) equipped an end-on type detector, and absorption coefficient of particles ($a_p(\lambda, z)$) was determined from the OD according to the Quantitative Filter Technique (QFT) (Mitchell, 1990). The filter was then soaked in methanol to extract and remove the pigments (Kishino et al., 1985) and absorption coefficient of detritus ($a_d(\lambda, z)$) was quantified again. Absorption coefficient of phytoplankton, $a_{ph}(\lambda, z)$, was calculated as a difference between values before and after the pigments extraction. After optical density of the suspended sample (OD_s) was measured, the sample was filtrated on a GF/F filter and its optical density (OD_f) was measured. For measurements of spectral absorption coefficient of CDOM ($a_{CDOM}(\lambda, z)$), 250 ml of water sample was filtrated through a 0.2 μ m Nuclepore filter (Whatman, ϕ 47 mm). OD of the filtrate water against pure water (Milli-Q) was measured with 10 cm cylindrical quartz cell and spectrophotometer, MPS-2400 (Shimadzu), and calculated $a_{CDOM}(\lambda, z)$.

D) Phytoplankton pigments (HPLC)

Seawater samples for phytoplankton pigments were collected from the sea surface and fixed depths (10, 20, 35, 50 and 75 m) or depths corresponding to 25%, 10%, 5%, 2.5% and 1% of incident PAR using Niskin-X bottles on a CTD/Rosset Multi Sampler (Sea-Bird Electronics Inc.).

Phytoplankton in 2.2 L of water samples were filtered on a glass fiber filter (Whatman GF/F, ϕ 25 mm) and stored in liquid nitrogen. Pigments concentration will be determined with a high performance liquid chromatography (HPLC) according to a method of Van Heukelem and Thomas (2001) in a laboratory after the cruise.

(5) Results

As a preliminary result, validation of an algorithm to estimate phytoplankton size index S_f . S_f is defined as the fraction of chlorophyll-*a* attribute to larger than 5 μm cells to total and calculated by following equation,

$$S_f = \frac{C_{>5}}{C_{\text{total}}},$$

where, $C_{>5}$ and C_{total} indicate chlorophyll-*a* detected from larger than 5 μm sized meshes and sum of all sized ones when filtered (see 4.8). S_f values were estimated from remote sensing reflectance ($R_{rs}(\lambda)$), which calculated from $L_w(\lambda,0^-)$ and $E_d(\lambda,0^+)$ measured by PRR-800/810 (see (4)-A), using a size index derivation model (SDM) proposed in Fujiwara et al. in prep.. Figure 2 present the performance of SDM comparing modeled S_f with *in-situ* S_f . Data was combined with the same data taken in other cruises (R/V Mirai MR09-03 and R/V Hakuho-maru KH09-4). This result exhibits that it is expected to be retrieve S_f with 76% accuracy within $\pm 20\%$ error range using satellite remote sensing. SDM is the first ocean color algorithm that can estimate algal size structure with its ratio. Thus, near future when the SDM applied to satellite ocean color remote sensing for the study area, it is expected that variability of not only chlorophyll-*a* but also S_f will be assessed in spatial and temporal scales.

(6) Data archives

These data obtained in this cruise will be submitted to the Data Integration and Analysis Group (DIAG) of JAMSTEC, and will be opened to the public via “R/V Mirai Data Web Page” in JAMSTEC home page.

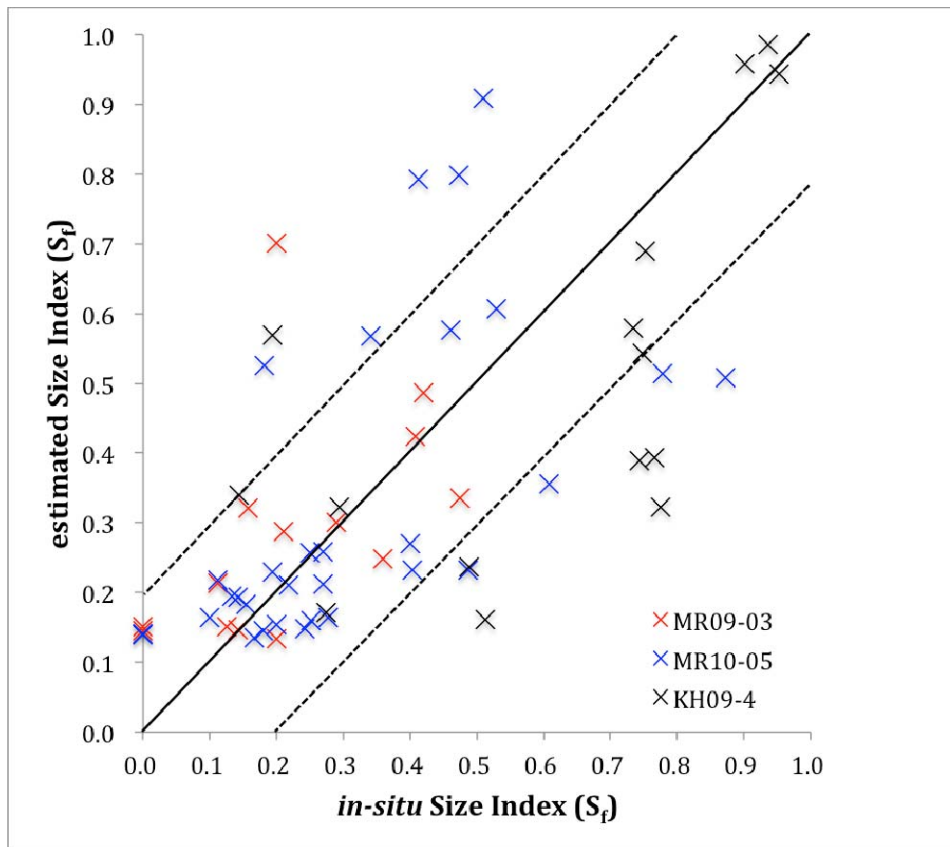

Figure 4.10-2. Comparison between model-derived and *in-situ* S_f . We used 60 valid retrievals.

4.11. Dissolved Iron (Fe)

(1) Personnel

Robert Rember	(IARC/UAF): Principal Investigator (PI)
Ana Aguilar-Islas	(IMS/UAF): Co-PI

(2) Objectives

Iron is an essential micronutrient with a hybrid-type distribution (Bruland and Lohan, 2004) influenced by essentially all the external and internal inputs and all the removal processes. With the current interest in iron's role as an important limiting micronutrient and in Fe fertilization of the oceans (de Baar et al., 2005; Boyd et al., 2007), there is a pressing need to better understand the natural Fe distribution and cycling. We have collected seawater samples for Fe analysis during this cruise. Results will be compared with previous observations observed during cruises of R/V Mirai in 2008. For stations collected where dissolved Fe was collected in concert with productivity casts, data will be used to determine whether Fe plays a role in limiting production in this region of the Arctic Ocean.

(3) Parameter

Dissolved Fe

(4) Instruments and methods

Seawater samples were collected in clean teflon-lined 12L Niskin bottles mounted directly on the provided Kevlar wire and then transferred into clean fluorinated 1L LDPE bottles. The sampling list is summarized in Table 4.11-1. Samples are filtered in the ships' clean room and stored at room temperature and will be analyzed by isotope dilution HR-ICPMS at the International Arctic Research Center at the University of Alaska, Fairbanks. Results will be reported as nanomole per liter (nM).

(5) Data archives

These data obtained in this cruise will be submitted to the Data Integration and Analysis Group (DIAG) of JAMSTEC, and will be opened to the public via "R/V Mirai Data Web Page" in JAMSTEC home page.

Table 4.11-1 Sampling list for Dissolved Fe

Sample #	Station	Niskin #	Depth (m)
1	28	1	20
2	28	2	50
3	28	3	80
4	28	4	120
5	28	5	160
6	49	1	10
7	49	2	20
8	49	3	50
9	49	4	110
10	49	5	150
11	56	1	15
12	56	2	55
13	56	3	120
14	56	4	240
15	56	5	320
16	70	1	20
17	70	2	53
18	70	3	250
19	70	4	445
20	70	5	750
21	81	1	20
22	81	2	55
23	81	3	260
24	81	4	450
25	81	5	750
26	111	1	15
27	111	2	50
28	111	3	23
29	111	4	93
30	111	5	193
31	154	1	20
32	154	2	70
33	154	3	236
34	154	4	470
35	154	5	750

4.12. Bacterial community structures and its growth characteristics in the Pacific Arctic Ocean

(1) Personnel

Motoo UTSUMI (Univ. of Tsukuba)

Chie SATO (Univ. of Tsukuba)

Shohei AKIYAMA (Univ. of Tsukuba)

Masao Uchida (NIES; National Institute for Environmental Studies)

(2) Objectives

Marine microbes, especially bacteria, are large and essential components of food webs and elemental cycles in the water column and sediment. Marine bacteria include the two deepest divisions, or domains, Bacteria and Archaea. These domains are identified by genetic distance in the composition of the 16S rRNA gene (Woese et al., 1990). Marine bacteria are small and morphologically simple: rods, spheres and filaments generally less than 1-2 μm in size, but they are highly diverse in terms of both taxonomy and metabolism. There are many different varieties of bacteria existing in the marine ecosystem, but it has been long noted a discrepancy of several orders of magnitude between the number of bacterial cells that can be seen in the oceans by direct count (by epifluorescence microscopy) (Hobbie et al., 1977) and the number of colonies that appear on agar plates (Jannasch and Jones, 1959). In terms of carbon cycling in marine ecosystems, especially for dissolved organic carbon (DOC), one of the most important activities of bacteria is aerobic decomposition. In recent years, it is reported that nonthermophilic Archaea, named Crenarchaeota, represent up to 40% of the free-living prokaryotic bacteria community in the water column of the world's oceans (DeLong, 1992), and some of their population is chemoautotrophy (Pearson et al., 2001). Therefore, it is important to study the relationship between carbon cycling and archaeal metabolic information in marine systems.

The key aim of this study is to analyze the metabolic characteristics of marine archaea, and relationship between their biomass, community structures and carbon cycling in Arctic Ocean ecosystem.

We also collected sea-water samples for measuring the radioactive isotope ratio and concentration of DIC and DOC, and for counting bacterial population density (Bacteria and Archaea) in the water column. One of the final goals of this study is making a mass balance model for carbon in the water column of Arctic Ocean.

(3) Parameters

Sample collection

< For analysis of marine bacterial community structure and their growth rate >

To collect filter samples for studying the diversity of bacterial community and their

functional genes, we collected water sample with CTD Niskin bottle from stations (Table 1). The water samples were moved to glass on deck. Then the samples were filtrated through 0.2 μm polycarbonate membrane filter (Whatman, 47 mm in diameter), and stored in -80°C during the cruise.

We also collected bacterial incubation samples to analyze the metabolic characteristics and growth rate of marine Bacteria and Archaea with CTD Niskin bottles from 1 or 2 depths per 1 station (Table. 2). These sea water samples were transformed to 2 L glass brown bottles, and were added ^{13}C labeled Bicarbonate or Leucine as soon as possible and immediately start the incubation in cold boxes adjusted at in situ water temperature. After ca. 6, 18, 27h, incubation was stopped, and these samples were fixed with parahormaldehyde (final conc. 2~4%) or filtrated with 47 mm polycarbonate membrane filter (Whatman, 47 mm in diameter) for extraction DNA/RNA. We also collected samples in the same sampling station of DNA extraction and incubation. These samples with fixing paraformaldehyde (final concentration in the sample was 2~4%, 100 mL plastic bottle) were then filtered with 0.2 μm polycarbonate membrane filter (Whatman, 25 mm in diameter) for counting the population density of Bacteria and Archaea (Table 3) on board. The filters were frozen at -80°C during the cruise.

<For analysis of isotope carbon contents of marine bacteria, DIC, DOC, and POC>

To analyze stable and radioactive carbon isotope ratio of POC and bacterial cell membrane lipids (especially GDGTs), we filtered 200 to 400 L sea-water samples at the stations (Table 4). These samples were collected from one or two depths (from 42 to 2,032 dBar) with X-Niskin water samplers (12 L, General Oceanic). Sea-water in the samplers immediately transferred to 10 L plastic canteens on deck. All water samples were filtered with quartz fiber filters (Whatman QM-A, 142 mm in diameter) as soon as possible on board. Then, the filtrates filtered again with 0.2 μm polycarbonate membrane filter (Advantec, 142 mm in diameter). The both filters were frozen at -20°C during the cruise.

Also we collected filter (POC) and filtrate (DOC) samples, and DIC and DI14C samples from routine water sampling of some CTD stations (Table 5 and 6). Sea-water in the samplers immediately transferred to 2 L plastic bottles for POC and DOC analysis, 250 ml glass bottles for DIC and DI14C on deck. All water samples for POC and DOC were filtered with QM-A filters (47 mm in diameter) and filtrate was collected in 1L PE bottles, as soon as possible on board. The filters and filtrates are frozen at -20°C during the cruise. DIC and DI14C samples were then immediately poisoned with 0.1 mL of a 7.0 % HgCl_2 solution and stored at 4°C during the cruise.

(4) Instruments and methods

To study the radioactive isotope ratio of POC and bacterial cell membrane lipids, and diversity of bacterial community in surface sea-water, we filtered surface sea-water (total 144,500 L, see Table 7) continuously during the cruise. The filtration system was set up in the surface sea-water analysis room in R/V MIRAI. The equipment was consist of steel-wool part, 10 µm size filter part, 1.0 µm size filter part, 0.2µm size filter part, and flowmeters (inflow and outflow, respectively). The maximum filtration velocity was about 8 L/min. Each filter was exchanged new one when the filtration velocity declined under 3 L/min or the filtration period exceeded 7 days. The collected filters were frozen at -20°C during the cruise. Radiocarbon measurements for DIC, POC, DOC, and biomarkers such as GDGTs derived from marine Crenarchaeota membrane lipids will be measured by Accelerator Mass Spectrometry (AMS) at AMS facility(NIES-TERRA), National Institute for Environmental Studies.

References

- DeLong, E.F. 1992. Archaea in coastal marine environments: *Proc Natl Acad Sci U S A*, **89**: 5685-5689.
- Hobbie, J.E., Daley, R.J., and Jasper, S. 1977. Use of nuclepore filters for counting bacteria by fluorescence microscopy: *Appl Environ Microbiol*, **33**: 1225-1228.
- Jannasch, H.W., and Jones, G.E. 1959. Bacterial populations in sea water as determined by different methods of enumeration: *Limnol. Oceanogr.*, **4**: 128-139.
- Pearson, A., McNichol, A.P., Benitez-Nelson, B.C., Hayes, J.M., and Eglinton, T.I. 2001. Origins of lipid biomarkers in Santa Monica Basin surface sediment: A case study using compound-specific Delta C-14 analysis: *Geochimica Et Cosmochimica Acta*, **65**: 3123-3137.
- Woese, C.R., Kandler, O., and Wheelis, M.L. 1990. Towards a natural system of organisms: proposal for the domains Archaea, Bacteria, and Eucarya: *Proc Natl Acad Sci U S A*, **87**: 4576-4579.

Table 4.12-1. List of filtrated sea-water samples for analysis of bacterial community structure during MR10-05.

Date	Station No.	Longitude	Latitude	Sampling depth (db)
2010/9/10	22	150-13.80 W	71-57.60 N	5, 10, 50, 100, 200, 300, 499, 1000, 1500, 1999, 2500, 2999
2010/9/16	35	169-59.40 W	78-15.60 N	5, 10, 50, 100, 200, 300, 500, 1000, 1499, 2000, 2500, 2561
2010/9/18	40	179-36.00 E	76-27.00 N	5, 10, 50, 101, 200, 300, 500, 1000, 1155
2010/9/21	56	173-59.40 W	76-15.00 N	5, 10, 50, 100, 200, 300, 499, 1000, 1500, 2243

2010/9/23	65	166-20.40 W	77-15.60 N	5, 10, 50, 100, 200, 300, 499, 810
2010/9/23	68	164-58.20 W	79-11.40 N	5, 10, 50, 100, 200, 300, 500, 1000, 1500, 2000, 2453
2010/9/25	77	157-0.60 W	76-37.20 N	5, 10, 50, 100, 200, 300, 500, 1000, 1080
2010/9/30	109	159-24.00 W	72-40.80 N	5, 10, 50, 67
2010/10/1	116	155-19.68 W	74-4.30 N	5, 10, 50, 100, 200, 300, 500, 1000, 1499, 2000, 2501, 3000
2010/10/3	126	167-35.88 W	73-58.90 N	5, 10, 50, 100, 200, 300, 500, 1000, 1498, 1990
2010/10/5	133	164-58.50 W	76-15.80 N	5, 10, 50, 100, 200, 300, 454
2010/10/8	149	156-41.04 W	76-15.80 N	5, 10, 50, 100, 200, 300, 500, 1000, 1200
2010/10/9	154	157-30.18 W	74-1.00 N	5, 10, 50, 100, 200, 300, 500, 1000, 1500, 1998, 2500, 3000
2010/10/10	160	163-44.76 W	74-37.40 N	5, 10, 50, 100, 200, 300, 500, 1000, 1014
2010/10/12	166	167-59.94 W	69-59.90 N	5, 10, 20, 35, 38
2010/10/13	172	168-49.92 W	67-0.10 N	5, 10, 20, 36

Table 4.12-2. List of filtrated sea-water samples for calculating bacterial growth rate and their metabolisms, MR10-05.

Date	Station No.	Longitude	Latitude	Sampling depth (db)
2010/9/5	12	168-0.00 W	70-0.00 N	10, 38
2010/9/10	22	150-13.80 W	71-57.60 N	250,
2010/9/16	35	169-59.40 W	78-15.60 N	212, 1000
2010/9/19	43	177-58.80 E	75-13.80 N	185, 341
2010/9/23	68	164-58.20 W	79-11.40 N	215, 2453
2010/10/1	116	155-19.68 W	74-4.30 N	264, 3914
2010/10/6	140	168-0.00 W	75-0.00 N	159,
2010/10/8	149	156-41.04 W	73-43.20 N	264, 1000
2010/10/10	160	163-44.76 W	74-37.40 N	1014,
2010/10/12	166	167-59.94 W	69-59.90 N	10, 38
2010/10/13	172	168-49.92 W	67-0.10 N	10, 36

Table 4.12-3. List of filtrated sea-water samples for counting Bacterial and Archaeal cell number, MR10-05.

Date	Station No.	Longitude	Latitude	Sampling depth (db)
2010/9/5	7	168-55.20 W	67-40.20 N	5, 10, 20, 35, 41
2010/9/5	12	168-0.00 W	70-0.00 N	5, 10, 20, 35, 38
2010/9/7	18	170-56.40 W	74-36.00 N	100, 200
2010/9/10	22	150-13.80 W	71-57.60 N	5, 10, 50, 100, 200, 300, 500, 1000, 1500, 2000, 2500, 3000, 3054
2010/9/12	28	155-6.00 W	71-43.80 N	5, 10, 20, 50, 100, 150, 239
2010/9/13	29	157-58.80 W	71-20.40 N	109
2010/9/16	35	169-59.40 W	78-15.60 N	5, 10, 50, 100, 200, 300, 500, 1000, 1500, 2000, 2500, 2561
2010/9/18	40	179-36.00 E	76-27.00 N	5, 10, 50, 101, 200, 300, 500, 1000, 1155
2010/9/19	43	177-58.80 E	75-13.80 N	5, 50, 100, 200, 300, 341
2010/9/19	45	179-0.00 E	75-0.00 N	180, 257
2010/9/21	55	174-0.00 W	75-50.40 N	300, 1000
2010/9/21	56	173-59.40 W	76-15.00 N	5, 10, 50, 100, 200, 300, 500, 1000, 1500, 2243
2010/9/23	65	166-20.40 W	77-15.60 N	5, 10, 50, 100, 200, 300, 500, 810
2010/9/23	68	164-58.20 W	79-11.40 N	5, 10, 50, 100, 200, 300, 500, 1000, 1500, 2000, 2453
2010/9/24	69	165-0.00 W	78-58.20 N	278, 1015
2010/9/25	77	157-0.60 W	76-37.20 N	5, 10, 50, 100, 199, 300, 500, 1000, 1080
2010/9/30	109	159-24.00 W	72-40.80 N	5, 10, 50, 67
2010/10/1	114	157-28.38 W	73-19.90 N	267, 2032
2010/10/1	116	155-19.68 W	74-4.30 N	5, 10, 50, 100, 200, 300, 500, 1000, 1500, 2000, 2500, 3000, 3914
2010/10/2	120	158-59.76 W	74-48.00 N	191, 1014
2010/10/3	126	167-35.88 W	73-58.90 N	5, 10, 50, 100, 200, 300, 500, 1000, 1500, 1990
2010/10/5	132	165-48.96 W	76-26.50 N	200
2010/10/5	133	164-58.50 W	76-15.80 N	5, 11, 50, 100, 200, 300, 454
2010/10/6	140	168-0.00 W	75-0.00 N	5, 10, 50, 100
2010/10/8	149	156-41.04 W	73-43.20 N	5, 10, 50, 100, 200, 300, 500, 1000, 1200
2010/10/9	154	157-30.18 W	74-1.00 N	5, 10, 50, 100, 200, 300, 500, 1000, 1500, 2000, 2500, 3000, 3903
2010/10/10	160	163-44.76 W	74-37.40 N	5, 10, 50, 100, 200, 300, 500, 1000, 1014
2010/10/12	166	167-59.94 W	69-59.90 N	5, 10, 20, 35, 38
2010/10/13	172	168-49.92 W	67-0.10 N	5, 10, 20, 36

Table 4.12-4. List of filtrated sea-water samples for stable and radioactive carbon isotope ratio of POM, DOM and bacterial cell membrane lipids during MR10-05.

Date	Station No.	Longitude	Latitude	Sampling depth (db)
2010/9/5	11	168-49.80 W	69-30.00 N	10, 42
2010/9/7	18	170-56.40 W	74-36.00 N	100, 200
2010/9/11	27	155-10.80 W	71-43.80 N	130, 201
2010/9/13	29	157-58.80 W	71-20.40 N	109
2010/9/19	45	179-0.00 E	75-0.00 N	180, 257
2010/9/21	55	174-0.00 W	75-50.40 N	300, 1000
2010/9/24	69	165-0.00 W	78-58.20 N	278, 1015
2010/10/1	114	157-28.38 W	73-19.90 N	267, 2032
2010/10/2	120	158-59.76 W	74-48.00 N	191, 1014
2010/10/5	132	165-48.96 W	76-26.50 N	200

Table 4.12-3. List of samples for stable and radioactive carbon isotope ratio, and concentration of DOC and POC during MR10-05.

Date	Station No.	Longitude	Latitude	Sampling depth (db)
2010/9/5	7	168-55.20 W	67-40.20 N	5, 10, 20, 35, 41
2010/9/5	11	168-49.80 W	69-30.00 N	10, 42
2010/9/5	12	168-0.00 W	70-0.00 N	5, 10, 20, 35, 38
2010/9/7	18	170-56.40 W	74-36.00 N	100, 200
2010/9/10	22	150-13.80 W	71-57.60 N	5, 10, 20, 35, 50, 75, 100, 125, 150, 175, 200, 225, 251, 275, 300, 400, 500, 700, 1000, 1500, 1999, 2500, 2999, 3054
2010/9/11	27	155-10.80 W	71-43.80 N	130, 201
2010/9/12	28	155-6.00 W	71-43.80 N	5, 10, 20, 35, 50, 75, 100, 125, 150, 175, 200, 239
2010/9/13	29	157-58.80 W	71-20.40 N	109
2010/9/16	35	169-59.40 W	78-15.60 N	5, 10, 20, 35, 50, 76, 100, 125, 150, 175, 200, 225, 250, 275, 300, 400, 500, 700, 1000, 1500, 2000, 2500, 2561,
2010/9/19	43	177-58.80 E	75-13.80 N	6, 11, 20, 35, 50, 75, 100, 125, 150, 175, 200, 225, 250, 275, 300, 341
2010/9/19	45	179-0.00 E	75-0.00 N	180, 257
2010/9/21	55	174-0.00 W	75-50.40 N	300, 1000
2010/9/22	62	168-55.80 W	77-8.40 N	5, 10, 20, 35, 50, 75, 100, 125, 150, 175, 200,

				225, 250, 275, 300, 400, 500, 700, 1000, 1500
2010/9/23	68	164-58.20 W	79-11.40 N	5, 10, 20, 35, 50, 75, 100, 125, 150, 175, 200, 250, 300, 400, 500, 700, 1000, 1500, 2000, 2453
2010/9/24	69	165-0.00 W	78-58.20 N	278, 1015
2010/9/25	77	157-0.60 W	76-37.20 N	5, 10, 20, 35, 50, 75, 100, 125, 150, 175, 200, 225, 250, 275, 300, 400, 500, 700, 1000, 1080
2010/10/1	114	157-28.38 W	73-19.90 N	267, 2032
2010/10/1	116	155-19.68 W	74-4.30 N	5, 10, 20, 35, 50, 75, 100, 125, 150, 175, 200, 225, 250, 275, 300, 400, 500, 700, 1000, 1500, 2000, 2500, 3000, 3914
2010/10/2	120	158-59.76 W	74-48.00 N	191, 1014
2010/10/5	132	165-48.96 W	76-26.50 N	200
2010/10/9	154	157-30.18 W	74-1.00 N	5, 10, 20, 35, 50, 75, 100, 125, 150, 175, 200, 225, 250, 275, 300, 400, 500, 700, 1000, 1500, 2000, 2500, 3000, 3903
2010/10/10	160	163-44.76 W	74-37.40 N	5, 10, 20, 35, 50, 75, 100, 125, 150, 175, 200, 225, 250, 275, 300, 400, 500, 700, 1000, 1014

Table 4.12-4. List of samples for DIC and DI¹⁴C during MR10-05.

Date	Station No.	Longitude	Latitude	Sampling depth (db)
2010/9/5	MC012	167-59.99 W	69-59.99 N	49
2010/9/7	18	170-56.40 W	74-36.00 N	100, 200
2010/9/9	MC01	153-46.69 W	71-57.30 N	408
2010/9/11	27	155-10.80 W	71-43.80 N	130, 200
2010/9/13	29	157-58.80 W	71-20.40 N	109
2010/9/16	35	169-59.40 W	78-15.60 N	5, 10, 20, 35, 50, 76, 100, 125, 150, 175, 200, 226, 250, 275, 299, 400, 500, 700, 1000, 1500, 2000, 2500, 2561
2010/9/17	39	175-15.00 W	76-0.00 N	5, 10, 20, 35, 50, 75, 100, 125, 150, 175, 200, 225, 250, 275, 301, 400, 500, 700, 1000, 1500, 2000, 2118
2010/9/18	MC039	175-15.00 W	76-0.00 N	2121
2010/9/19	45	179-0.00 E	75-0.00 N	180, 257
2010/9/21	55	174-0.00 W	75-50.40 N	300, 1000
2010/9/24	69	165-0.00 W	78-58.20 N	278, 1015
2010/10/1	114	157-28.38 W	73-19.90 N	267, 2032

2010/10/1	115	156-59.58 W	73-28.60 N	5, 10, 20, 35, 50, 75, 100, 125, 150, 175, 200, 300, 400, 500, 700, 1000, 1500, 2000, 2500, 3000, 3351
2010/10/2	120	158-59.76 W	74-48.00 N	191, 1014
2010/10/2	PL03	165-14.95 W	74-22.51 N	356
2010/10/3	MC126	162-0.29 W	75-0.03 N	1972
2010/10/5	132	165-48.96 W	76-26.50 N	200
2010/10/11	165	164-45.30 W	70-29.80 N	10, 20, 35

Table 4.12-5. List of samples for mega filtration of surface sea-water during MR10-05.

Start	Stop	Pore size (μm)	Sample No.	Filtered vol. (L)
2010/9/14	2010/9/16	0.2	1	15560
2010/9/16	2010/9/19	0.2	2	20690
2010/9/19	2010/9/21	0.2	3	18630
2010/9/21	2010/9/26	0.2	4	26820
2010/9/26	2010/9/28	0.2	5	15120
2010/10/5	2010/10/9	0.2	6	20900
2010/10/9	2010/10/11	0.2	7	26470
2010/9/14	2010/9/21	10, 1.0	1	55190
2010/9/21	2010/9/28	10, 1.0	2	41940
2010/10/5	2010/10/11	10, 1.0	3	47370

4.13. Phytoplankton and microzooplankton

(1) Personnel

Naomi Harada	(JAMSTEC): Principal Investigator
Katsunori Kimoto	(JAMSTEC)
Yusuke Okazaki	(JAMSTEC)
Yoshihiro Shiraiwa	(Tsukuba Univ.)
Manami Satoh	(Tsukuba Univ.)
Jonaotaro Onodera	(JSPS/JAMSTEC)

(2) Objective

1. Understanding of phytoplankton and microzooplankton assemblages. Shell bearing planktons such as diatoms and foraminifers are the main research targets.
 - Water sampling for phytoplankton floral analysis
 - Tow net for microzooplankton analysis
2. For phytoplankton culture, isolation of coccolithophores was performed in order to investigate the influence of drastic climate change of Arctic region on their physiological responses. With an eye to future Arctic environments, the culture experiments will be attempted on shore.

(3) Instruments and Methods

Phytoplankton assemblage analysis

Water samples were obtained by CTD, bucket, and from the water outlet in the “sea surface monitoring laboratory” on R/V MIRAI. The volume of sample waters was measured by measuring cylinder. The suspended particle matters including phytoplankton cells were gently gathered by suction filtration with vacuum pressure of -0.03MPa. The type of applied filter is the gridded mixed-cellulose ester filter with 0.45 μ m pore size. The filter diameter is 25mm for CTD and bucket waters, and 47mm for the pump waters. After desalting, the sample filter was dried in room-temperature, and was kept in sample box. These filters will be observed under light microscope and scanning electron microscope.

Microzooplankton

Microzooplankton samples were taken by vertical tow of single NORPAC plankton net (frame diameter: 45cm). Applied mesh size is 63 μ m. Target depth was 0-50m except for shallow stations. The towing was carried out from starboard side with vinyl-coated wire winch. The towing speed was 0.5 m s⁻¹. The obtained planktons were sieved by 45 μ m stainless-steel mesh and were gathered to one side of sieve with filtered sea water. The residue on 45 μ m sieve was washed down to the sample cup by ethanol. Foraminifers in these samples will be picked up during the MR10-06 cruise by Dr. Katsunori Kimoto. Further research will be continued after the sample arrival to laboratory.

Phytoplankton culture experiments

Collected natural sea water (NSW) was diluted with ESM medium or MNK medium (Table 4.13-1) and incubated in 24-well or 96-well plates under fluorescent light (light: dark=16:8) at 4 °C. After 1 week or more, microscopic observation was performed to check the growth of the phytoplankton. 1 L of NSW was concentrated to ca. 4 mL on filter paper ($\phi=47$ mm, 0.22 μm pore), in case of concentration. Concentrated NSW was used for culture sometimes.

Table 4.13-1. Compositions of media

Composition of ESM medium	
	Concentration
NaNO ₃ (anhydrous)	141 μM
K ₂ HPO ₄ (anhydrous)	28.7 μM
Thiamin HCl (VB1)	0.3 μM
Biotin (VH)	4.1 nM
Cyanocobalamine (VB12)	0.7 nM
Na ₂ SeO ₃	9.8 nM
Fe-EDTA Na \cdot 3H ₂ O	61.5 nM
Mn-EDTA \cdot 3H ₂ O	74.9 nM
pH 8.2 (in natural sea water)	
Composition of MNK medium	
	Concentration
NaNO ₃ (anhydrous)	235 μM
Na ₂ HPO ₄ \cdot 12H ₂ O	0.78 μM
K ₂ HPO ₄ (anhydrous)	5.7 μM
Thiamin HCl (VB1)	0.06 μM
Biotin (VH)	0.6 nM
Cyanocobalamine (VB12)	0.1 nM
Na ₂ SeO ₃	0.17 nM
Fe-EDTA Na \cdot 3H ₂ O	61.5 nM
Mn-EDTA \cdot 3H ₂ O	74.9 nM
Na ₂ EDTA \cdot 2H ₂ O	10 nM
MnCl ₂ \cdot 4H ₂ O	45 nM
ZnSO ₄ \cdot 7H ₂ O	8.3 nM
CoSO ₄ \cdot 7H ₂ O	4.3 nM
Na ₂ MoO ₄ \cdot 2H ₂ O	3 nM
CuSO ₄ \cdot 5H ₂ O	0.24 nM
pH 8.7 (in natural sea water)	

(5) Station list or Observation log

Phytoplankton assemblage analysis

The sample list in Tables 4.13-2 and 4.13-3

Microzooplankton analysis

The sample list in Table 4.13-4

Phytoplankton culture

The lists of the 7 stations during leg1 and 43 stations (14: surface water, 29: CTD) during leg2 were attached (Tables 4.13-5, 4.13-6, and 4.13-7). The 39 stations in arctic sea were shown in Figure 4.13-1. The other 11 stations in North Pacific and the Bering Sea were shown in Figure 4.13-2.

(6) Result

Phytoplankton culture

The cells looked like coccolithophores were investigated in the culture from st.024 and s10 by the end of the cruise.

(7) Data archives

These data obtained in this cruise will be submitted to the Data Integration and Analysis Group (DIAG) of JAMSTEC, and will be opened to the public via “R/V Mirai Data Web Page” in JAMSTEC home page.

Table 4.13-2. Filtered volume (L) of near-surface waters supplied at “sea surface monitoring laboratory” on R/V MIRAI. The data of SST and salinity are from SOJ monitor.

ID in Meta Date Sheet	Lat. (N)	Long. (E)	Date and Time (UTC)	Water Vol. (L)	SST (°C)	SAL
MR10-05 SPM-Pump01-W43	67.9667	-168.8167	2010/9/05 10:47	0.87	7.55	31.40
MR10-05 SPM-Pump02-W44	71.4950	-168.1167	2010/9/06 11:34	1.50	6.09	30.68
MR10-05 SPM-Pump03-W45	77.9667	-168.7167	2010/9/15 07:34	6.01	-1.10	26.80
MR10-05 SPM-Pump04-W46	78.5500	-169.0167	2010/9/15 20:31	4.99	-1.27	27.35
MR10-05 SPM-Pump05-W47	77.1762	-168.3803	2010/9/23 02:23	6.89	-0.70	26.34
MR10-05 SPM-Pump06-W48	74.0025	-162.0140	2010/9/27 21:03	5.02	1.42	27.76
MR10-05 SPM-Pump07-W49	72.4967	-162.0017	2010/9/28 05:27	2.00	2.96	31.26

Table 4.13-3. Filtered volume (L) of CTD waters. The symbol "--" represents no sample.

Sta._ Cast#	Lat. (N)	Long. (E)	Bucket	5m	10m	20m	35m	50m	75m	100m	150m	Chl. Max (Sampled Depth, m)
1_1	65.75	-168.50	0.35	0.40	0.40	0.40	0.50	--	--	--	--	0.40 (14)
6_1	67.00	-168.84	0.30	0.30	0.30	0.30	0.30	--	--	--	--	0.30 (4)
10_1	69.01	-168.84	0.35	0.35	0.35	0.35	0.35	--	--	--	--	0.35 (30)
12_1	72.00	-168.00	0.35	0.35	0.35	0.35	0.35	--	--	--	--	0.35 (14)
15_1	73.00	-168.00	0.40	0.50	0.35	0.40	0.40	--	--	--	--	0.26 (29)
16_1	74.00	-168.01	0.75	0.68	0.77	0.68	0.74	0.72	0.76	0.74	--	0.65 (40)
18_2	74.60	-171.10	0.76	0.64	0.67	0.64	0.72	0.75	0.74	0.69	0.63	0.68 (99)
22_1	71.96	-150.23	0.67	0.58	0.67	0.69	0.69	0.66	0.70	0.70	0.66	0.70 (50)
23_1	71.66	-151.23	0.63	0.67	0.69	0.68	0.71	0.68	0.81	0.79	0.67	0.77 (42)
25_1	71.46	-151.81	0.74	--	0.76	0.72	0.82	0.77	--	--	--	--
26_1	71.37	-153.28	0.62	--	0.68	0.72	0.72	0.73	--	--	--	--
28_1	71.74	-155.09	0.74	0.68	0.69	0.75	0.68	0.68	0.67	0.61	0.67	0.64 (21)
35_1	78.26	-169.99	0.73	0.72	0.67	0.63	0.64	0.63	0.81	0.63	0.59	0.63 (48)
39_1	76.00	-175.25	0.74	0.78	0.68	0.74	0.67	0.65	0.73	0.74	0.63	0.72 (53)
42_1	75.41	178.21	0.67	0.66	0.79	0.75	0.71	0.66	0.76	0.63	0.72	0.67 (63)
44_1	75.00	177.72	0.63	--	--	0.64	--	0.73	--	--	--	0.74 (35)
48_1	75.08	-176.00	0.67	0.71	0.73	0.74	0.70	0.66	0.68	0.60	0.68	0.65 (61)
58_1	76.67	-172.00	0.79	--	0.63	0.69	0.74	0.63	0.65	0.66	0.65	0.71 (55)
65_1	77.26	-166.34	0.71	--	0.63	0.67	0.70	0.69	0.61	0.71	--	0.66 (60)
68_1	79.19	-164.98	0.65	--	0.68	0.80	0.73	0.75	0.68	0.64	--	0.65 (50)
70_1	78.87	-165.00	0.65	--	--	--	--	--	--	--	--	0.72 (54)
71_1	77.76	-163.79	0.67	--	--	--	0.71	--	0.71	--	--	0.67 (64)
72_1	77.76	-161.99	0.65	--	--	--	0.71	--	0.73	--	--	0.71 (62)
77_1	76.62	-157.01	0.96	--	--	--	0.66	--	0.74	--	--	0.92 (61)
78_1	76.39	-154.72	0.71	--	--	--	0.62	--	0.68	--	--	0.96 (60)
83_1	75.86	-158.09	0.71	--	--	--	--	--	--	--	--	0.75 (45)
86_1	71.01	-162.00	0.50	--	--	0.35	--	--	--	--	--	0.28 (30)
87_1	71.11	-159.32	--	--	--	--	--	--	--	--	--	0.22 (39)
92_1	71.41	-157.50	0.50	--	--	--	--	--	--	--	--	0.43 (26)
106_1	72.18	-157.18	0.50	--	--	--	--	--	--	--	--	0.30 (33)
107_1	72.50	-160.00	0.50	--	--	--	--	--	--	--	--	0.40 (23)
111_1	72.88	-158.20	0.41	--	--	--	0.51	--	0.36	--	--	0.40 (16)
116_1	74.08	-155.33	0.70	--	--	--	0.68	--	0.70	--	--	0.61 (64)
121_1	74.38	-165.28	0.60	--	--	--	0.64	--	0.65	--	--	0.75 (35)
125_1	73.98	-167.58	0.66	--	--	--	0.66	--	0.65	--	--	0.67 (28)
126_1	75.00	-162.01	0.62	0.64	0.74	0.74	0.74	0.69	0.60	0.62	0.66	0.85 (30)
128_1	76.00	-165.50	0.70	--	--	--	0.69	--	0.68	--	--	0.76 (30)
131_1	76.52	-166.86	0.64	--	--	--	0.65	0.69	0.76	--	--	0.65 (25)
139_1	75.00	-167.23	0.83	--	--	--	0.74	--	0.63	--	--	0.76 (30)
143_1	73.71	-162.76	0.56	--	--	--	0.65	0.68	--	--	--	0.63 (15)
158_1	74.18	-160.50	0.62	--	--	--	0.68	0.70	--	--	--	0.67 (23)
161_1	74.75	-163.00	0.68	--	--	--	0.66	0.68	--	--	--	0.66 (15)

Table 4.13-4. Vertical tow samples of single NORPAC plankton net. The no log data was represented by the symbol “-”.

Station	Lat. (N)	Long. (E)	Date (LST)	Start Time (LST)	Wire Angle (°)	Wire Out (m)	End Time (LST)
1	65.7500	-168.5000	2010/09/04	15:00	5	50	-
6	67.7226	-168.0882	2010/09/04	10:00	2	50	16:00
12	70.2378	-167.9935	2010/09/05	42:00	0	40	48:00
17	74.9988	-168.3000	2010/09/07	16:00	4	40	22:00
18	74.6017	-170.9332	2010/09/07	28:00	4	50	-
23	71.6608	-151.2363	2010/09/10	29:00	0	50	-
26	71.3663	-152.1185	2010/09/10	19:00	0	50	-
28	71.7583	-155.0035	2010/09/12	48:00	0	50	55:00
35	78.2587	-169.9873	2010/09/16	40:00	0	50	46:00
39	76.0097	-174.9758	2010/09/17	14:00	0	50	20:00
42	75.4063	178.2142	2010/09/18	07:00	0	50	14:00
44	74.9982	177.7235	2010/09/18	25:00	4	50	30:00
48	74.9995	-176.0202	2010/09/19	38:00	0	50	44:00
58	76.6733	-171.9925	2010/09/22	42:00	2	50	48:00
65	77.2635	-166.3358	2010/09/22	36:00	2	50	42:00
70	78.8767	-165.0063	2010/09/23	54:00	2	50	59:00
72	77.7505	-162.0220	2010/09/24	22:00	0	50	27:00
77	76.6168	-157.0483	2010/09/25	03:00	2	50	09:00
86	70.9992	-162.0002	2010/09/28	10:00	2	40	15:00
92	71.4120	-157.4750	2010/09/28	32:00	3	50	38:00
106	72.1832	-157.1820	2010/09/30	07:00	0	50	14:00
107	72.4997	-159.9958	2010/09/30	04:00	0	40	09:00
111	72.8838	-158.8060	2010/09/30	06:00	0	50	11:00
116	74.0642	-155.3037	2010/10/01	56:00	0	50	02:00
121	74.3758	-165.2515	2010/10/02	31:00	6	50	37:00
125	73.9818	-167.2515	2010/10/02	52:00	2	50	-
126	75.0037	-161.9888	2010/10/03	46:00	0	50	52:00

Table 4.13-5. Stations, date, position (latitude and longitude), medium, dilution rate and plate during leg1. Surface sea water samples were obtained using the shipboard seawater supply for research use.

Station	Date (UTC) yyyy/m/d h:mm	Latitude	Longitude	medium	dilution rate	plate*
08	2010/8/26 4:08	40 24.67 N	148 22.71 E	ESM, MNK	1/1000 1/200	96 24
09	2010/8/26 22:04	42 10.64 N	153 12.13 E	ESM, MNK	1/1000 1/200	96 24
02	2010/8/28 1:23	46 20.94 N	159 53.94 E	ESM, MNK	1/1000 1/200	96 24
10	2010/8/28 20:53	49 19.34 N	164 58.09 E	ESM, MNK	1/1000 1/200	96 24
03	2010/8/29 15:03	52 03.19 N	169 55.56 E	ESM, MNK	1/1000 1/200	96 24
05	2010/8/30 19:39	53 40.54 N	179 58.97 W	ESM, MNK	1/1000 1/200	96 24
11	2010/8/31 16:42	54 01.90 N	171 55.95 W	ESM, MNK	1/1000 1/200	96 24

*Plate is indicated by the number of wells per plate.

Table 4.13-6. Stations, date, position (latitude and longitude), medium, dilution rate and plate during leg2. Surface sea water samples were obtained using the shipboard seawater supply for research use.

Station	Date (UTC) yyyy/m/d h:mm	Latitude	Longitude	Medium	Dilution Rate	Plate *
s01	2010/9/3 19:28	60 07.65 N	168 00.89 W	ESM, MNK	1/1000 1/200	96 24
s02	2010/9/4 2:03	61 47.23 N	167 21.97 W	ESM, MNK	1/1000 1/200	96 24
s03	2010/9/4 16:25	65 26.28 N	168 34.82 W	ESM, MNK	1/1000 1/200	96 24
s04	2010/9/5 19:07	69 25.67 N	168 49.81 W	ESM, MNK	1/1000 1/200	96 24
s05	2010/9/6 21:40	73 12.07 N	168 02.23 W	ESM, MNK	1/500 1/200	96 24
s06	2010/9/7 22:10	74 35.98 N	171 0.207 W	ESM, MNK	1/300 1/200	96 24
s07	2010/9/9 5:16	73 4.145 N	158 49.71 W	ESM, MNK	1/300	24
s08	2010/9/12 4:05	71 47.85 N	155 20.64 W	ESM MNK	2/5 10	24 24
s09	2010/9/13 3:30	71 38.58 N	156 22.87 W	MNK ESM MNK	1/2 10 10	24 96 96
s10	2010/9/14 0:40	72 46.04 N	162 1.732 W	ESM MNK	1/25 1/25	96 96
s11	2010/9/28 3:10	72 58.09 N	162 0.068 W	ESM, MNK	1/300	24
s12	2010/9/30 11:00	72 20.81 N	158 34.75 W	ESM	1/2 1/20	96 96
s13	2010/10/13 19:00	65 07.14 N	168 37.45 W	ESM	1/2 1/4 1/20 1/40	96 96 96 96
s14	2010/10/14 22:15	61 45.19 N	167 22.45 W	ESM	1/2 1/4 1/20 1/40	96 96 96 96
s15	2010/10/15 18:50	56 58.09 N	167 11.00 W	ESM	1/2 1/4 1/20 1/40	96 96 96 96

*Plate is indicated by the number of wells per plate.

Table 4.13-7. Stations, depth, medium, dilution rate and plate during leg2. The water samples were collected at CTD stations.

Station	Depth (m)	Medium	Dilution Rate	Plate*
st.024	20	ESM	1/2	24
		MNK	10	24
st.030	20	ESM	1/2	24
		MNK	10	24
st.035	20	ESM	1/2	24
		MNK	6	24
st.038	35	MNK	8	24
		MNK	1/2	24
st.043	20	ESM	1/10, 1/50, 1/100, 1/200, 1/500, 1/1000	96
		MNK	1/10, 1/50, 1/100, 1/200, 1/500, 1/1000	96
st.051	10	ESM	1/10, 1/50, 1/100, 1/200, 1/500, 1/1000	96
		MNK	1/10, 1/50, 1/100, 1/200, 1/500, 1/1000	96
st.058	10	ESM,	1/300	24
		MNK	1/4, 1/8, 1/16, 1/32, 1/64, 1/128, 1/256, 1/512	96
st.063	20	ESM, MNK	1/200	24
			1/4, 1/8, 1/16, 1/32, 1/64, 1/128, 1/256, 1/512	96
			1/200	24
st.068	20	ESM, MNK	1/4, 1/8, 1/16, 1/32, 1/64, 1/128, 1/256, 1/512	96
			1/300	24
st.075	35	ESM, MNK	1/4, 1/8, 1/16, 1/32, 1/64, 1/128, 1/256, 1/512	96
			1/300	24
st.078	50	ESM, MNK	1/4, 1/8, 1/16, 1/32, 1/64, 1/128, 1/256, 1/512	96
			1/300	24
st.082	50	ESM, MNK	1/300	24
st.113	50	ESM	1/2	96
			1/20	96
st.115	50	ESM	1/2	96
			1/20	96
st.116	50	ESM	1/2	96
			1/20	96
st.119	50	ESM	1/2	96
			1/20	96
st.123	20	ESM	1/2	96
st.126	35	ESM	1/20	96
			1/2	96
st.129	50	ESM	1/2	96
			1/20	96
			30	96

Table 4.13-7. (cont.)

st.137	35	ESM	1/2 1/20	96 96
st.142	35	ESM	1/2 1/20	96 96
st.143	20	ESM	1/2 1/20	96 96
st.148	20	ESM	1/2 1/20	96 96
st.150	20	ESM	1/2 1/20	96 96
st.154	35	ESM	1/2 1/20	96 96
st.158	Chl-max	ESM	1/2 1/20	96 96
st.162	20	ESM	1/2 1/20	96 96
st.165	10	ESM	1/2 1/20	96 96
st.166	10	ESM	1/2 1/20	96 96
st.171	0	ESM	1/4 1/40	96 96

*Plate is indicated by the number of wells per plate.

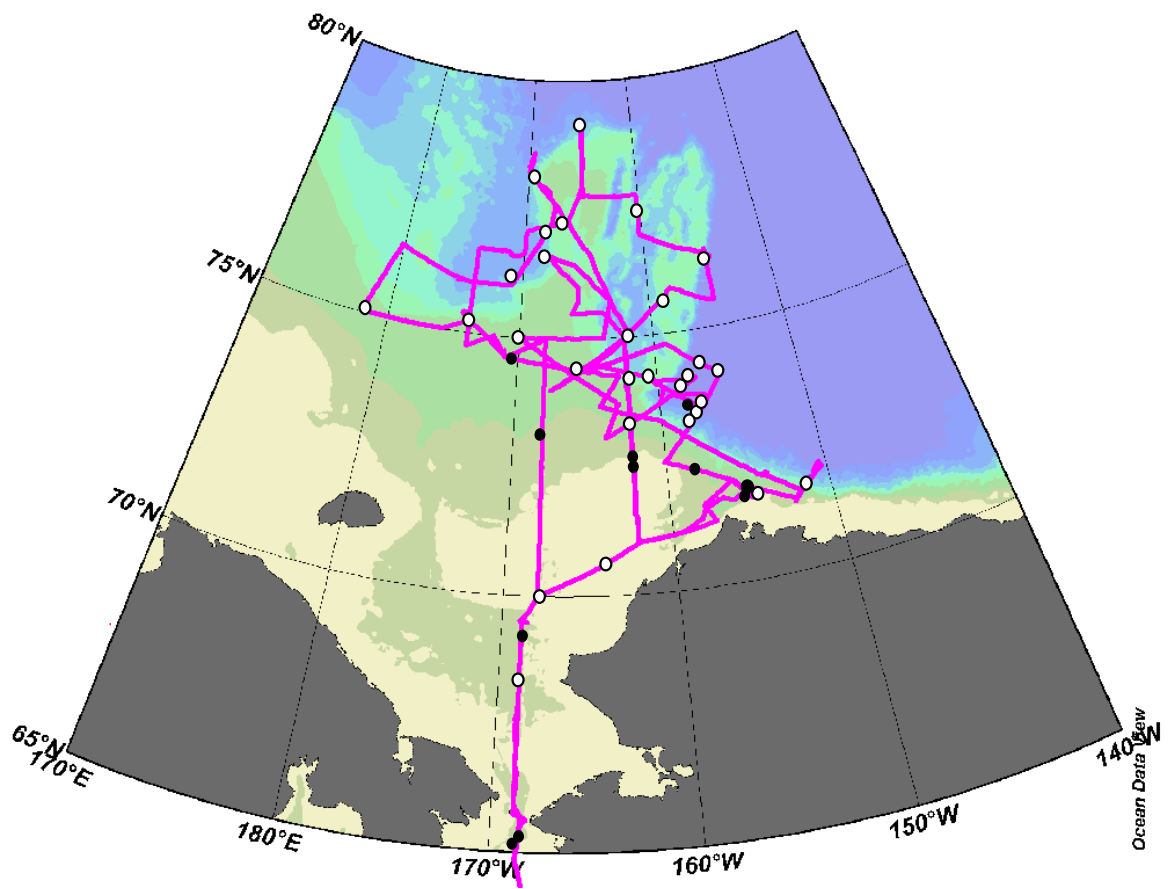

Figure 4.13-1. Water sampling stations for phytoplankton culture in arctic sea. (●), from shipboard supply waters in underway. (○), from CTD-Niskin bottle or bucket.

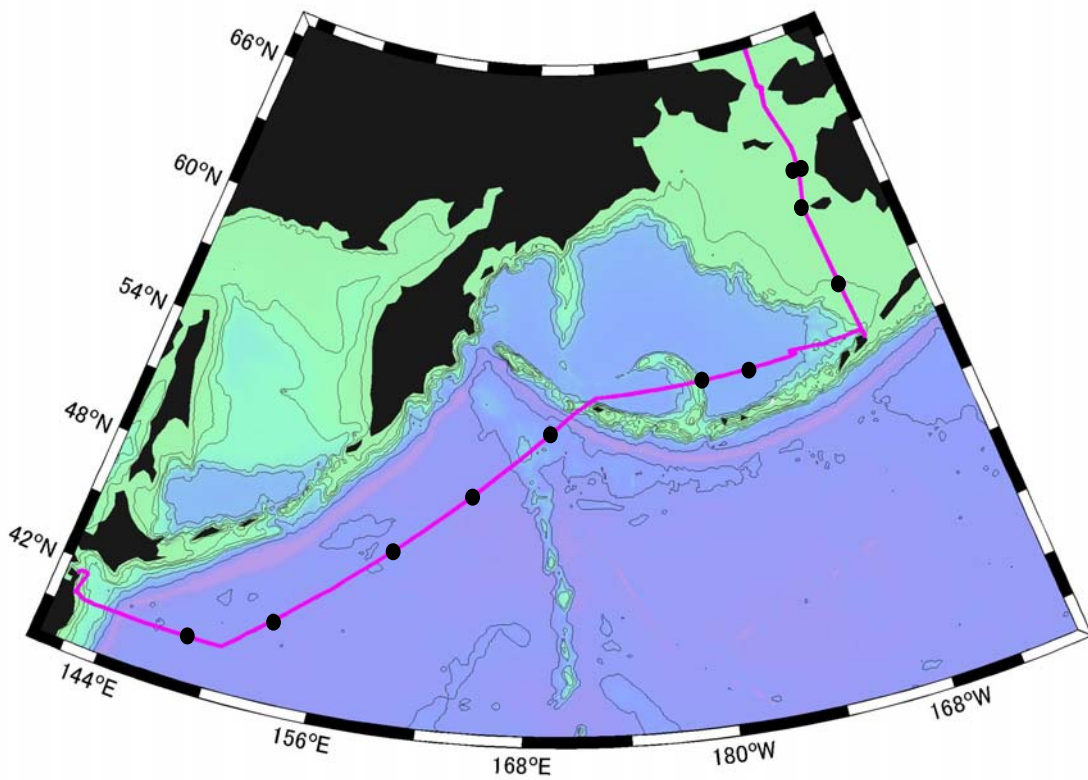

Figure 4.13-2. Water sampling stations for phytoplankton culture in North Pacific and the Bering Sea from shipboard supply waters in underway (●).

4.14. Zooplankton

(1) Personnel

Kohei Matsuno (Hokkaido University)

Atsushi Yamaguchi (Hokkaido University): Principal Investigator

(2) Objective

After 1990s, decreasing of sea ice in the Arctic Ocean is reported in the western Arctic Ocean because of increasing the amount of the warm Pacific water passed into the Arctic Ocean. The Pacific water passed through the Bering Strait may induce intrusion of the Pacific originated zooplankton to the Arctic Ocean. Previously, the transported Pacific zooplankton is considered to be died off. It has been reported to be extinct transportation (invalid dispersion) because the amount of the transported zooplankton was few before 1990s. The transported zooplankton by Pacific water is composed by mainly copepods (*Neocalanus cristatus*, *N. flemingeri*, *N. plumchrus*, *Eucalanus bungii*, *Metridia pacifica*) which dominant components in the North Pacific Ocean.

The zooplankton fauna in the Arctic Ocean is known to be completely varied with that in the North Pacific. Early copepodid stages of the Pacific copepods (e.g. *Neocalanus* spp.) grow and store oil in their body during phytoplankton bloom. Pre-adult stage (C5) of the Pacific copepods descent into deeper layer (>1000 m), mature and spawn at that depth. While the spawning of the Arctic copepods (e.g. *Calanus glacialis*, *C. hyperboreus*, *Metridia longa*) is known to occur at epipelagic zone with grazing during phytoplankton bloom. Thus, the utilization of phytoplankton bloom varied with species fauna: i.e. the Pacific species utilize as energy of growth of young, while the Arctic species as energy of reproduction of adults. Therefore, the Pacific copepods may use the energy of the phytoplankton bloom more efficiently than the Arctic copepods, and biological efficiency of the Pacific copepods is known to be higher than that of the Arctic copepods (Parsons and Lalli, 1988).

In the western Arctic Ocean where the sea ice is decreasing, the Pacific copepods may induce and be inhabited, but the details of their ecological impact has not been evaluated.

The goals of this study are following:

- 1) Estimate the amount of the transported Pacific copepods into the Arctic Ocean.
- 2) Evaluate physical conditions (gut pigment and lipid accumulation) of the Pacific and Arctic copepods in the Arctic Ocean.
- 3) Clarify the grazing impact of the transported Pacific copepods to the Arctic Ocean

ecosystem.

(3) Sampling

Zooplankton samples were collected by vertical haul of two types of nets at 63 stations in the western Arctic Ocean. Twin NORPAC net (mesh: 335 μm , mouth diameter: 45 cm) was towed between surface and 150 m depth or bottom -5 m (stations where the bottom shallower than 150 m) at all stations (Fig. 4.14-1 and Table 4.14-1 and 2). One zooplankton sample collected by the NORPAC net were immediately fixed with 5% buffered formalin for zooplankton structure analysis. Another sample was used for evaluation of the copepod physiological activity (i.e. wet mass, dry mass, ash-free dry mass and gut pigment). The volume of water filtered through the net was estimated from the reading of a flow-meter mounted in the mouth ring. Also, we collected some water samples from 0, 10, 20 m and chlorophyll maximum layer at towed NORPAC stations to investigate phytoplankton community in the western Arctic Ocean. The samples were immediately fixed with 1% glutaraldehyde.

80 cm ring net (mesh: 335 μm , mouth diameter: 80 cm) was towed between surface and 150 m depth or bottom -5 m at 13 stations (Table 4.14-3), fresh samples were used for grazing experiments and/or measurement of gut evacuation rate. Also, the 80 cm ring net was towed between surface and 100 or 1000 m depth at 6 stations, the fresh samples were immediately fixed with 99.5% ethyl alcohol for analysis DNA of zooplankton (investigator: Yasuhiro Takenaka [AIST] and John Nelson [IOS]).

Also, we collected six core samples from above 3 cm a part of the core with a multiple corer at 6 stations in Chukchi Sea in order to reveal geographical distribution of phytoplankton cyst abundance (Table 4-14-4) (investigator: Chiko Tsukazaki [Hokkaido University]).

(4) On-board treatment

[Individual wet weight, dry weight, ash-free dry mass and gut pigment]

Fresh zooplankton samples collected with NORPAC net were immediately added with 10% soda water (CO_2 water) used for gut pigment analysis. We sorted with late copepodid stages of the Pacific copepods (*Neocalanus cristatus*, *N. plumchrus*, *N. flemingeri*, *Eucalanus bungii*, *Metridia pacifica*) and the Arctic copepods (*Calanus glacialis*, *C. hyperboreus*, *M. longa*). Some specimens were rinsed with distilled water, transferred into pre-weighted aluminum pan and stored in -30°C . On land laboratory, these samples will be weighed for wet mass, dry mass, ash-free dry mass with a precision of 0.01 g using an electronic balance. Other specimens transferred into a

cuvette tube immersed with 6 ml dimethylformamide, stored and extracted for >24 hours. After extract the pigment, these samples were measured fluorescence with a Turner model 10-005-R Filter Fluorometer.

[Gut evacuation rate]

Calanus glacialis C5 or *Metridia longa* C6F were sorted from fresh zooplankton samples collected with 80 cm ring net using a dissection microscope every 5 to 10 minutes during 1 hour, and were placed into a cuvette tube. Gut pigments of these samples were measured by the same procedure shown previously.

[Grazing rate experiment] (by Matsuno, Fujiwara, Yamaguchi and Hirawake)

Pacific copepods (*Neocalanus cristatus* C5, *N. plumchrus* C5, *N. flemingeri* C5, *Eucalanus bungii* C4F or C5F) and Arctic copepods (*Calanus glacialis* C5, *C. hyperboreus* C6F and *Metridia longa* C6F) were sorted from fresh zooplankton samples collected with 80 cm ring net. This selection was made only individuals that were actively swimming and undamaged. A variable number of these specimen was restored into 0.6 or 2.4 L polycarbonate bottles filled ambient sea water filtered 200 µm mesh from chlorophyll maximum layer or surface, and were incubated for 24h in a experiment cistern on-deck with running surface sea water and ambient light condition. Pre- and after-incubated water was filtered gently (<100 mmHg) through three different sized meshes (<2, 2–10 and >10 µm). Chlorophyll-*a* was extracted by placing the filters in DMF (*N, N-dymethyl formamide*) for 24 h at -20°C. Chlorophyll-*a* concentrations were determined by a Turner Designs fluorometer (10-AU) with non-acidification method (Welschmeyer, 1994). We calculated the clearance rate, F (ml copepod⁻¹ d⁻¹) on each size fraction of chlorophyll-*a* using the equation of Liu *et al.* (2007) based on the formula of Frost (1972).

(5) Results

As a preliminary results, we present following items.

Figure 4.14-1: Location of the plankton net sampling stations.

Figure 4.14-2: Geographical distribution of gut pigment of *C. glacialis* C5.

Figure 4.14-3: Geographical distribution of gut pigment of *C. glacialis* C6F.

Figure 4.14-4: Geographical distribution of gut pigment of *C. hyperboreus* C6F.

Figure 4.14-5: Geographical distribution of gut pigment of *M. longa* C6F.

(6) Reference

Parsons, T. R. and C. M. Lalli (1988) Comparative oceanic ecology of the plankton communities of the subarctic Atlantic and Pacific Oceans. *Oceanogr. Mar. Biol.*

Annu. Rev., **26**, 317-359.

Welschmeyer, N. A. (1994) Fluorometric analysis of chlorophyll *a* in the presence of Chlorophyll *b* and pheopigments. *Limnol. Oceanogr.*, 39, 1985-1992.

Liu, H., M. J. Dagg, J. M. Napp and R. Sato (2007) Mesozooplankton grazing in the coastal Gulf of Alaska: *Neocalanus* spp. vs. other mesozooplankton. *ICES J. Mar. Sci.*, 65, 351-360.

Frost, B. W. (1972) Effects of size and concentration of food particles on the feeding behavior of the marine planktonic copepod *Calanus pacificus*. *Limnol. Oceanogr.*, 17, 805-815.

Table 4:14-1. Data on plankton samples collected by vertical hauls with a NORPAC net.
GG54: 0.33 mm mesh.

Station no.	Position		S.M.T.		Length of wire (m)	Angle of wire (°)	Depth estimated by wire angle (m)	Kind of cloth	Flowmeter		Estimated volume of water filtered (m ³)	Remark
	Lat. (N)	Lon.	Date	Hour					No.	Reading		
001	65-46	168-30 W	4 Sept	11:00	50	7	50	GG54	1852	243	3.72	1)
004	66-00	168-50 W	4 Sept	16:09	49	3	49	GG54	1852	468	7.16	
006	67-00	168-50 W	4 Sept	22:02	40	3	40	GG54	1852	409	6.25	
008	68-00	168-50 W	5 Sept	3:33	50	3	50	GG54	1852	533	8.15	
010	69-00	168-50 W	5 Sept	9:03	45	2	45	GG54	1852	460	7.03	
012	70-00	167-59 W	5 Sept	15:50	44	1	44	GG54	1852	478	7.31	
017	75-00	168-00 W	7 Sept	0:05	150	3	150	GG54	1852	1362	20.83	
018	74-36	170-56 W	7 Sept	9:54	152	10	150	GG54	1852	1388	21.23	
019	74-16	162-35 W	8 Sept	7:50	150	1	150	GG54	1852	1380	21.10	
021	73-40	164-06 W	8 Sept	13:45	150	1	150	GG54	1852	1390	21.26	
023	71-40	151-15 W	10 Sept	13:20	150	2	150	GG54	1852	1358	20.77	
026	71-22	152-07 W	10 Sept	19:45	60	2	60	GG54	1852	548	8.38	
028	71-44	155-05 W	12 Sept	13:50	151	6	150	GG54	1852	1403	21.46	
035	78-16	169-54 W	16 Sept	6:32	150	2	150	GG54	1852	1378	21.07	
038	77-38	167-29 W	16 Sept	15:20	150	2	150	GG54	1852	1430	21.87	
041	76-00	178-55 E	18 Sept	9:35	150	3	150	GG54	1852	1483	22.68	
044	75-00	177-43 E	18 Sept	20:13	150	4	150	GG54	1852	1360	20.80	
046	75-00	180-00	19 Sept	1:52	150	2	150	GG54	1852	1350	20.65	
048	75-00	176-01 W	19 Sept	9:13	151	6	150	GG54	1852	1440	22.02	
051	74-45	175-00 W	19 Sept	19:30	150	1	150	GG54	1852	1388	21.23	
053	75-25	174-00 W	21 Sept	5:20	150	1	150	GG54	1852	1361	20.81	
056	76-15	173-59 W	21 Sept	15:40	150	1	150	GG54	1852	1426	21.81	
058	76-40	172-00 W	22 Sept	1:33	150	1	150	GG54	1852	1421	21.73	
062	77-09	168-56 W	22 Sept	16:06	150	1	150	GG54	1852	1361	20.81	
065	77-16	166-20 W	22 Sept	23:27	150	1	150	GG54	1852	1400	21.41	
070	78-52	165-00 W	23 Sept	20:45	150	1	150	GG54	1852	1378	21.07	
072	77-45	162-01 W	24 Sept	17:01	150	3	150	GG54	1852	1425	21.79	
075	76-58	160-05 W	25 Sept	4:48	150	2	150	GG54	1852	1638	25.05	
077	76-37	157-03 W	25 Sept	11:53	150	2	150	GG54	1852	1604	24.53	
079	75-31	155-19 W	26 Sept	9:09	153	11	150	GG54	1852	1617	24.73	
086	71-00	162-00 W	28 Sept	7:05	38	1	38	GG54	1852	430	6.58	
087	71-06	159-19 W	28 Sept	12:40	75	5	75	GG54	1852	836	12.78	
092	71-25	157-29 W	28 Sept	19:22	119	5	119	GG54	1852	1392	21.29	1)
105	71-36	154-50 W	29 Sept	17:41	36	2	36	GG54	1852	374	5.72	
106	72-11	157-11 W	29 Sept	23:59	117	1	117	GG54	1852	1098	16.79	
107	72-30	160-00 W	30 Sept	5:56	41	2	41	GG54	1852	389	5.95	
111	72-53	158-48 W	30 Sept	11:55	150	1	150	GG54	1852	1387	21.21	
116	74-04	155-18 W	1 Oct	10:47	150	1	150	GG54	1852	1402	21.44	
119	74-41	158-19 W	1 Oct	21:56	150	4	150	GG54	1852	1593	24.36	
121	74-23	165-15 W	2 Oct	9:11	150	4	150	GG54	1852	1360	20.80	
125	73-59	167-36 W	2 Oct	21:33	151	8	150	GG54	1852	1372	20.98	
126	75-00	161-59 W	3 Oct	16:38	150	1	150	GG54	1852	1378	21.07	
128	76-00	165-30 W	4 Oct	6:56	150	1	150	GG54	1852	1381	21.12	
131	76-31	166-52 W	4 Oct	18:24	150	2	150	GG54	1852	1402	21.44	
135	75-44	162-57 W	5 Oct	5:54	150	1	150	GG54	1852	1402	21.44	
137	75-00	165-02 W	5 Oct	14:15	150	4	150	GG54	1852	1499	22.92	
142	75-00	170-00 W	6 Oct	0:27	150	2	150	GG54	1852	1377	21.06	

S.M.T. is Alaska local time (GMT-8h)

1) Including large Medusa

Table 4:14-2. Continued.

Station no.	Position		S.M.T.		Length of wire (m)	Angle of wire (°)	Depth estimated by wire (m)	Kind of cloth	Flowmeter		Estimated volume of water filtered (m ³)	Remark
	Lat. (N)	Lon.	Date	Hour					No.	Reading		
143	73-43	162-46 W	6 Oct	0:67	150	1	150	GG54	1852	1366	20.89	
144	73-03	163-45 W	6 Oct	20:55	92	4	92	GG54	1852	911	13.93	
146	73-29	161-00 W	7 Oct	3:45	150	1	150	GG54	1852	1430	21.87	
148	73-48	159-01 W	7 Oct	11:44	150	1	150	GG54	1852	1451	22.19	1)
151	73-44	158-27 W	8 Oct	3:57	150	1	150	GG54	1852	1402	21.44	
154	74-01	157-30 W	8 Oct	19:20	150	2	150	GG54	1852	1366	20.89	
158	74-11	160-30 W	9 Oct	15:06	150	1	150	GG54	1852	1220	18.66	
159	74-30	164-30 W	9 Oct	21:46	150	4	150	GG54	1852	1356	20.74	
164	71-00	162-00 W	11 Oct	6:30	39	1	39	GG54	1852	87	1.33	
165	70-30	164-45 W	11 Oct	13:45	38	1	38	GG54	1852	348	5.32	
166	70-00	168-00 W	11 Oct	19:39	40	2	40	GG54	1852	409	6.25	
168	69-00	168-50 W	12 Oct	6:55	45	4	45	GG54	1852	435	6.65	
170	68-00	168-50 W	12 Oct	12:20	51	1	51	GG54	1852	470	7.19	
172	67-00	168-50 W	12 Oct	18:53	40	1	40	GG54	1852	456	6.97	
174	66-00	168-50 W	13 Oct	8:24	47	6	47	GG54	1852	500	7.65	
175	65-46	168-30 W	13 Oct	11:35	51	1	51	GG54	1852	575	8.79	

Table 4.14-3. Data on plankton samples collected by vertical hauls with 80 cm ring net. GG54: 0.33 mm mesh.

Station no.	Position		S.M.T.		Length of wire (m)	Angle of wire (°)	Depth estimated by wire (m)	Kind of cloth	Remark
	Lat. (N)	Lon.	Date	Hour					
001	65-46	168-30 W	4 Sept	11:07	50	4	50	GG54	1)
012	70-00	167-59 W	5 Sept	16:00	44	1	44	GG54	1)
018	74-36	170-56 W	7 Sept	10:05	150	1	150	GG54	1)
022	71-58	150-14 W	10 Sept	6:30	100	5	100	GG54	2)
				6:37	1000	1	1000	GG54	3)
026	71-22	152-08 W	10 Sept	20:13	59	1	59	GG54	2)
028	71-44	155-04 W	12 Sept	14:01	150	8	149	GG54	1)
048	75-00	176-01 W	19 Sept	9:25	150	5	149	GG54	1)
081	75-40	156-18 W	26 Sept	15:05	1000	2	999	GG54	3)
087	71-06	159-19 W	28 Sept	12:47	74	3	74	GG54	1)
105	71-36	154-50 W	29 Sept	17:52	36	1	36	GG54	1)
116	74-04	155-19 W	1 Oct	9:52	1000	3	999	GG54	3)
121	74-23	165-15 W	2 Oct	9:21	150	2	150	GG54	1)
125	73-59	167-36 W	2 Oct	21:43	150	2	150	GG54	1)
126	75-00	162-00 W	3 Oct	17:18	1000	1	1000	GG54	3)
144	73-03	163-45 W	6 Oct	21:03	91	2	91	GG54	1)
151	73-44	158-27 W	8 Oct	4:08	150	2	150	GG54	1)
164	71-00	162-00 W	11 Oct	6:36	38	3	38	GG54	1)
170	68-00	168-50 W	12 Oct	12:27	50	2	50	GG54	1)

S.M.T. is Alaska local time (GMT-8h)

1) used for grazing experiment

2) IARC Nelson's ethanol sample

3) AIST Takenaka's ethanol sample

Table 4.14-4. Data on core samples collected by multiple corer.

Station no.	Position		S.M.T.	Remark
	Lat. (N)	Lon.	Date	
012	70-00	168-00 W	5 Sept	Bot. Depth = 45, sampled upper 3 cm core from handling 2 and 3
164	71-00	162-00 W	11 Oct	Bot. Depth = 45, sampled upper 3 cm core from handling 5 and 6
165	70-30	164-45 W	11 Oct	Bot. Depth = 45, sampled upper 3 cm core from handling 6 and 7
169	68-30	168-50 W	12 Oct	Bot. Depth = 52, sampled upper 3 cm core from handling 4 and 5
172	67-00	168-50 W	12 Oct	Bot. Depth = 47, sampled upper 3 cm core from handling 5 and 6
175	65-46	168-30 W	13 Oct	Bot. Depth = 56, sampled all core from handling 1 to 7

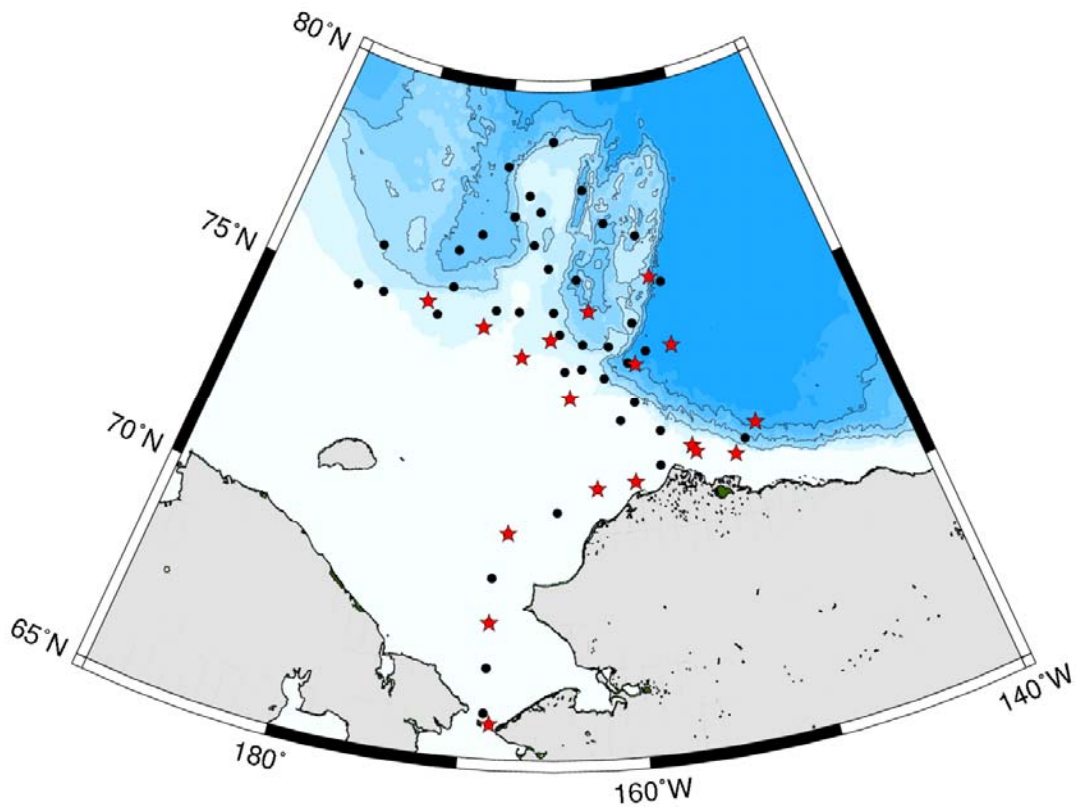

Fig. 4.14-1. Location of the sampling stations in the western Arctic Ocean (circles: NORPAC net, stars: NORPAC net + 80 cm ring net).

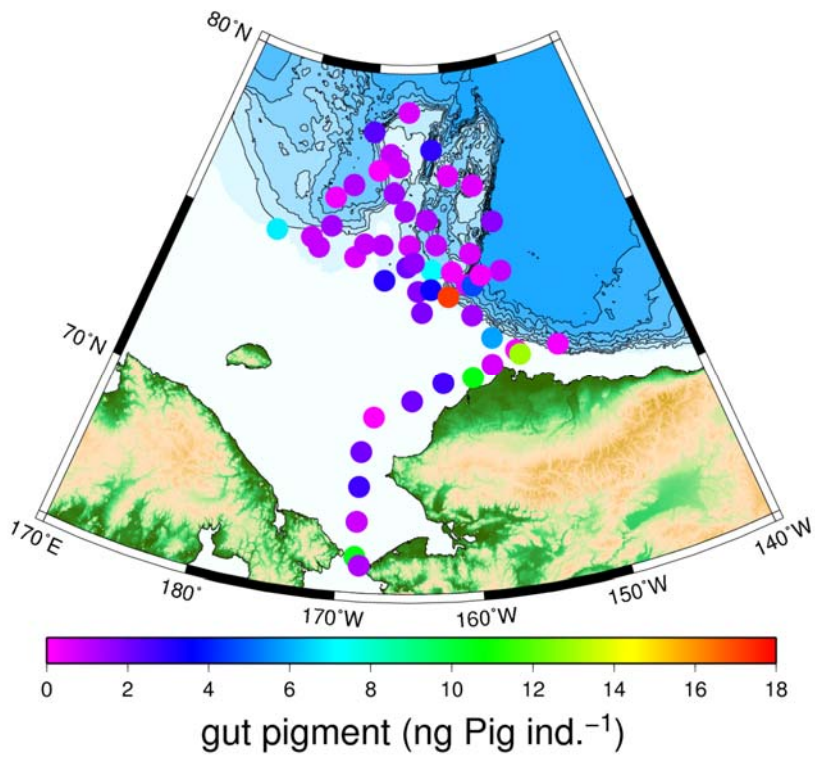

Fig. 4.14-2. Geographical distribution of gut pigment of *Calanus glacialis* C5.

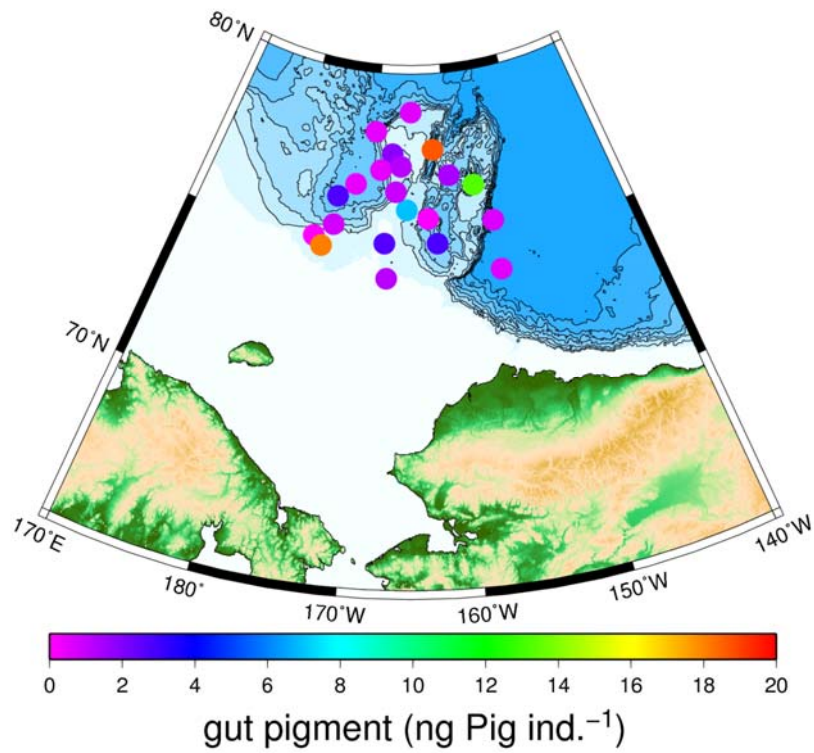

Fig. 4.14-3. Geographical distribution of gut pigment of *Calanus glacialis* C6F.

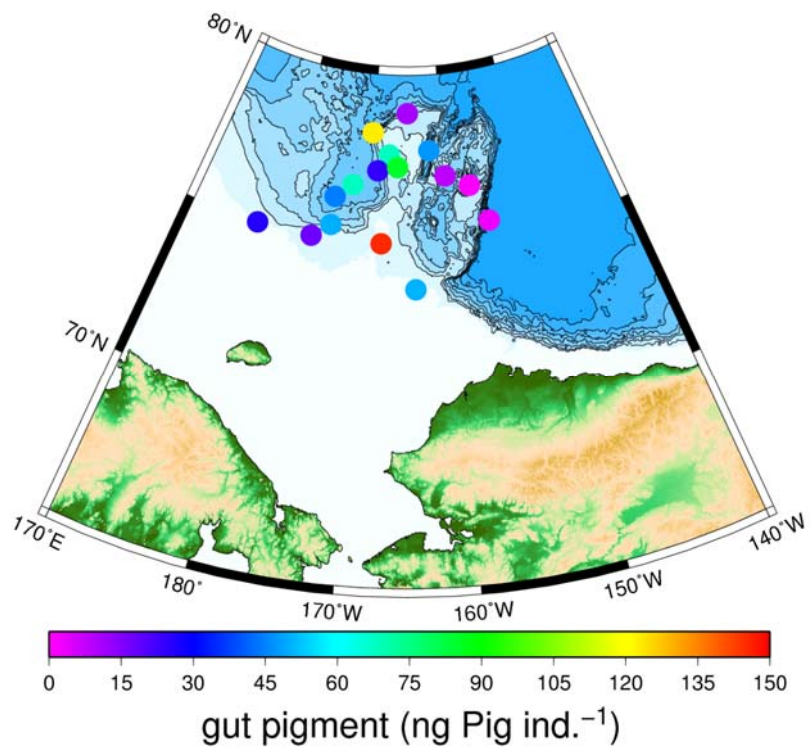

Fig. 4.14-4. Geographical distribution of gut pigment of *Calanus hyperboreus* C6F.

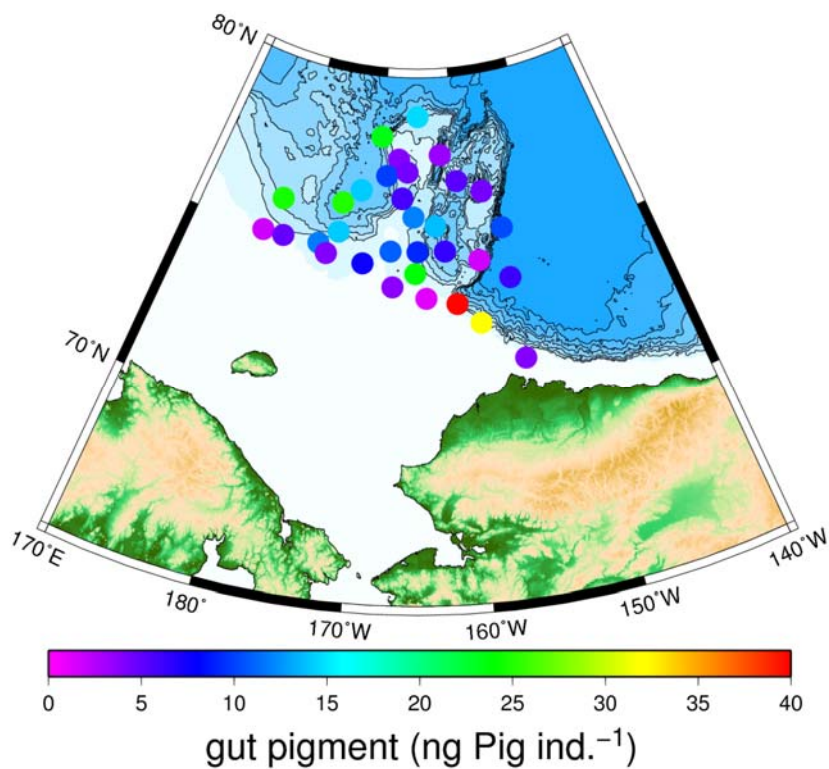

Fig. 4.14-5. Geographical distribution of gut pigment of *Metridia longa* C6F.

4.15. Sediment trap and sediment core sampling

(1) Personnel

Naomi Harada	(JAMSTEC): Principal Investigator
Katsunori Kimoto	(JAMSTEC)
Yusuke Okazaki	(JAMSTEC)
Kana Nagashima	(JAMSTEC)
Makio C. Honda	(JAMSTEC)
Sanae Chiba	(JAMSTEC)
Yuichiro Tanaka	(AIST)
Jonaotaro Onodera	(JSPS/JAMSTEC)
Tomohide Noguchi	(MWJ): Technical staff for moorings deployment
Hirokatsu Uno	(MWJ): for moorings deployment
Satoshi Ozawa	(MWJ): for moorings deployment
Yusuke Satoh	(MWJ): for MC operation and nondestructive measurements
Yasushi Hashimoto	(MWJ): for MC operation and nondestructive measurements
Yuki Miyajima	(MWJ): for MC operation and nondestructive measurements

(2) Objective

1. Deployment of sediment trap moorings

In order to monitor time-series change of biogeochemical cycles in the Arctic Ocean, sediment trap study started from this cruise. It has been considered that the pronounced decline of summer sea-ice area significantly influences to the sea-ice ecosystem and biogeochemical cycles. Multi-year monitoring of sinking particle flux will be helpful for the understanding of rapid environmental change in the study area. Two sediment traps were moored at each station to estimate the contribution of lateral advection of lithogenic materials in addition to sinking particles.

2. Understanding on the geochemical history in the Holocene

Surface sediments were taken by the multiple core sampler in order to decipher the recent biogeochemical history and the origin of lithogenic materials at sediment trap sites.

(3) Instruments and Methods

Sediment trap moorings

Instruments of sediment trap moorings are as shown in Table 4.15-1 and Figure 4.15-1. As ownership remarks, two acoustic releases at Station CAP10t, all of deployed sediment traps and glass buoys at Stations CAP10t and NAP10t were brought us by Dr. Yuichiro Tanaka, AIST. Two acoustic releases and their bundling parts at Station NAP10t are owned by the Arctic Ocean Climate System Research Team, JAMSTEC.

Sediment trap deployments were carried out at two points in the Northwind Abyssal Plain and the Chuckhi Abyssal Plain (Table 4.15-1, Figure 4.15-1). Station/deployment ID is NAP10t and CAP10t. The “10t” represents the sediment trap mooring deployed in 2010.

Sea waters for filling-up sampling cups were taken from 1000m water depth at Station 19 in the Northwind Abyssal Plain. The 1000m waters were filtered by membrane filter with 0.45 μ m pore size in order to remove suspended or sinking particles. As antiseptic of collected sample, formalin was added to the filtered water, and the concentration of formalin was 5%. The pH of filtered sea water with formalin was neutralized to approx. 7.8 by sodium tetraborate.

Before the test of acoustic responses of releases in water, the applied releases for Station CAP10t were diagonally attached to the CTD frame (Figure 4.15-2). When the casted CTD bearing two releases reached to near bottom at Station 39 (CAP10t), the acoustic response test was successfully done at 2060 m water depth. The release response test for NAP10t was conducted at Station 112. Because the double releases for Station NAP10t had been already bundled, the bundled releases were not attached to CTD frame, but were casted by vinyl-coated cable winch at starboard side. The wire-out length was 1000m when the release test was conducted.

The deployment was started from the top buoy of mooring at stern board. The deployment log is as listed in Table 4.15-2.

Surface sediments

The surface sediment sampling at sediment trap station was performed though the use of the multiple core sampler. This core sampler consists of a main body of 620kg-weight and eight acrylic tubes (I.D. 74mm; Length of 60cm). Before the sampling, bathymetric profiles were obtained around the sediment trap and core sites by the SEA BEAM 2100 Multi Beam Bathymetric Survey System equipped on R/V Mirai (Figure 4.15-1).

MSCL measurements

Gamma-ray attenuation (GRA), P-wave velocity (PWV), and magnetic susceptibility (MS) were measured at every 1cm on the MC of HAND 8 by the GEOTEK multi-sensor core logger. The measurements were carried out after that the core temperature became similar to room temperature. The measurement condition was based on the manuals of GEOTEK and MWJ. The image scanning was carried out after the CCR measurement.

CCR measurements

The Core Color Reflectance (CCR) on the archive half of HAND 8 was measured through crystal clear polyethylene wrap by using the Konica Minolta CM-700d. The measurement was carried out at every 2 cm. The measurement condition were as follows: wavelength of spectral reflectance: 400 to 700nm; measurement area: MAV (ϕ 8mm); specular component excluded (SCE); Illuminant: D₆₅; observer: 10°; and color spaces: L*a*b*.

Core Photographs

Sectional photographs of working half cores were taken using a single-lens reflex digital camera (Body: Nikon D1x / Lens: Nikon AF-Nikkor 24-50mm

1:3.3-4.5 D). The shutter speed was 1/20 ~ 1/30 sec. F-number was 5.6, 6.0, and 7.1. Sensitivity was ISO 125. File format of raw data is Exif-JPEG. Details for settings were included on property of each file. White correction was carried out using by the editing software (Adobe Photoshop Elements 6.0).

Soft X-ray photographs

In order to take the soft X-ray photographs, sediment samples were put into the original plastic cases (200x30x7mm) from the central area of archive half. Soft X-ray photographs were taken to using the device SOFTEX PRO-TEST 150 on board. Based on the results of MSCL density measurement, the condition of soft X-ray was set out as 45-50kVp, 1.5-2.0mA, and 140-200 seconds. All photographs were developed into the negative films by the device FIP-1400 on board. The negative films were scanned by Epson Offirio ES-10000G to TIFF image files of 24bit color and 300dpi. Afterward the images were carried out histogram coordination (highlight: 71; shadow: 2; gamma: 1.0).

(4) Station list or Observation log

Sediment trap deployments

The locality and deployment summary was shown in Table 4.15-1 and Figure 4.15-1.

The deployment log of sediment trap moorings in Table 4.15-2

The sample period of sediment trap bottles was listed in Table 4.15-3.

The layout of sediment trap moorings was shown in Figures 4.15-3 and 4.15-4.

Surface sediments

The core summary in Table 4.15-5.

The observation log of MC operation in Tables 4.15-6 and 4.15-7.

(5) Results

Surface sediments

Core photographs of MCst39 and MCst126 in Figures 4.15-5 and 4.15-6.

The data plots of MSCL and color reflectance in Figures 4.15-7 and 4.15-8.

The soft X-ray photographs in Figures 4.15-9 and 4.15-10.

Core descriptions in Figure 4.15-11 and 4.15-12.

(6) Data archives

These data obtained in this cruise will be submitted to the Data Integration and Analysis Group (DIAG) of JAMSTEC, and will be opened to the public via “R/V Mirai Data Web Page” in JAMSTEC home page.

Table 4.15-1. Summary of sediment trap deployments in the R/V Mirai Cruise MR10-05 Leg 2.

Deployment ID	Cruise Station	Coordinates	Water Depth (m)	Trap Depth (m) ^a	Trap Type	Acoustic Release Type	Sampling Duration
CAP10t	039	75°59.98' N 175°00.28' W	2117	257 1289	SMD26 S-6000 ^b	Model L ^b	Sep. 2010- Sep. 2011
NAP10t	126	75°00.01' N 162°00.17' W	1973	317 1349		Model L ^b / 8242XS ^c	Oct. 2010- Sep. 2011

^a Estimated depth with consideration of elongated doubler rope by 1kN mooring tension.

^b Nichiyu Giken Kobyu, Co. Ltd.; ^c EdgeTech (ORE Offshore)

Table 4.15-2. Deployment log of sediment trap moorings by Dr. Nishino, S.

Mooring ID	CAP-10t	NAP-10t
Project	MR10-05	MR10-05
Ship	R/V Mirai	R/V Mirai
Start Time of Deploy (UTC)	2010/9/17 21:58	2010/10/3 21:15
Start Position of Deploy	76°01.40'N 175°03.15'W	75°00.34'N 162°05.00'W (position at 21:33)
Time in Water of Instruments (UTC)		
Top Buoy (ABS resin)	22:00	ca. 21:20
Frame with Flag	22:00	ca. 21:20
Five Glass Buoys	22:02	ca. 21:20
Four Glass Buoys	22:02	ca. 21:20
Shallower Sediment Trap (300m)	22:12	21:33
Five Glass Buoys	22:33	
Deeper Sediment Trap (1300m)	22:43	22:04
Four Glass Buoys	23:06	22:18
Double release	23:06	22:18
Time of Sinker Release (UTC)	2010/9/17 23:20	2010/10/3 22:34
Position of Sinker Release	75°59.90'N 174°59.68'W	74°59.93'N 161°59.15'W

Table 4.15-3. The turn table event of sediment traps at Stations CAP10t and NAP10t. The schedules of shallow and deep traps are the same. Date is listed as local ship time (UTC-8:00). The symbol "--" represents open hole condition.

Event	Sample #	Date (LST)	Interval (days)	Sample #	Date (LST)	Interval (days)
	Station CAP10t			Station NAP10t		
Sinker Release		2010/09/17 15:20	--		2010/10/03 14:34	--
#01	CAP10t#01	2010/09/18 00:00	15	NAP10t#01	2010/10/04 00:00	14
#02	CAP10t#02	2010/10/03 00:00	15	NAP10t#02	2010/10/18 00:00	15
#03	CAP10t#03	2010/10/18 00:00	15	NAP10t#03	2010/11/02 00:00	15
#04	CAP10t#04	2010/11/02 00:00	15	NAP10t#04	2010/11/17 00:00	15
#05	CAP10t#05	2010/11/17 00:00	15	NAP10t#05	2010/12/02 00:00	15
#06	CAP10t#06	2010/12/02 00:00	15	NAP10t#06	2010/12/17 00:00	15
#07	CAP10t#07	2010/12/17 00:00	15	NAP10t#07	2011/01/01 00:00	15
#08	CAP10t#08	2011/01/01 00:00	15	NAP10t#08	2011/01/16 00:00	15
#09	CAP10t#09	2011/01/16 00:00	15	NAP10t#09	2011/01/31 00:00	15
#10	CAP10t#10	2011/01/31 00:00	15	NAP10t#10	2011/02/15 00:00	15
#11	CAP10t#11	2011/02/15 00:00	15	NAP10t#11	2011/03/02 00:00	13
#12	CAP10t#12	2011/03/02 00:00	14	NAP10t#12	2011/03/15 00:00	13
#13	CAP10t#13	2011/03/16 00:00	14	NAP10t#13	2011/03/28 00:00	13
#14	CAP10t#14	2011/03/30 00:00	14	NAP10t#14	2011/04/10 00:00	13
#15	CAP10t#15	2011/04/13 00:00	14	NAP10t#15	2011/04/23 00:00	13
#16	CAP10t#16	2011/04/27 00:00	14	NAP10t#16	2011/05/06 00:00	13
#17	CAP10t#17	2011/05/11 00:00	14	NAP10t#17	2011/05/19 00:00	13
#18	CAP10t#18	2011/05/25 00:00	14	NAP10t#18	2011/06/01 00:00	13
#19	CAP10t#19	2011/06/08 00:00	14	NAP10t#19	2011/06/14 00:00	13
#20	CAP10t#20	2011/06/22 00:00	14	NAP10t#20	2011/06/27 00:00	13
#21	CAP10t#21	2011/07/06 00:00	14	NAP10t#21	2011/07/10 00:00	13
#22	CAP10t#22	2011/07/20 00:00	14	NAP10t#22	2011/07/23 00:00	13
#23	CAP10t#23	2011/08/03 00:00	14	NAP10t#23	2011/08/05 00:00	13
#24	CAP10t#24	2011/08/17 00:00	14	NAP10t#24	2011/08/18 00:00	13
#25	CAP10t#25	2011/08/31 00:00	14	NAP10t#25	2011/08/31 00:00	14
#26	CAP10t#26	2011/09/14 00:00	14	NAP10t#26	2011/09/14 00:00	14
#27		2011/09/28 00:00	--		2011/09/28 00:00	--
Turnaround		planned in Oct. 2011	--		planned in Oct. 2011	--

Table 4.15-5. Core summary of MC at Stations 39 (CAP10t) and 126 (NAP10t). Some cores were supplied to NIES.

Core ID	Location	Coordinates	Depth (m)	HAND No.	Core Length (cm)*	Tension Max. (t)	Remarks
MCst39	Chukchi Abyssal Plain	76-00.53N 174-58.74W	2,121	HAND1	31.3	3.1	
				HAND2	23.9		To NIES
				HAND3	31.0		To NIES
				HAND4	30.6		
				HAND5	31.1		To NIES
				HAND6	30.8		
				HAND7	28.7		To NIES
				HAND8	29.5 (29.5)		Polycarbonate pipe; W-half to NIES; A-half & soft-X case to JAMSTEC
MCst126	Northwind Abyssal Plain	75-00.0316N 162-00.2932W	1,972	HAND1	32.5	3.1	
				HAND2	22.3		To NIES
				HAND3	32.5		
				HAND4	33.5		To NIES
				HAND5	32.5		
				HAND6	32.5		To NIES
				HAND7	31.0		
				HAND8	32.0 (32.7)		Polycarbonate pipe; W-half to NIES; A-half & soft-X case to JAMSTEC

Table 4.15-6. Observation log of MCst39.

Cruise Name:	MR10-05_Leg2	Operator:	Yuki Miyajima (MWJ)				
Date: (UTC)	2010/9/18						
Core Number:	MCst39						
Area:	Chukchi Abyssal Plain (CAP)						
Sampling Site:	St.39						
Weather:	Cloudy						
Wind direction:	123deg.	Wind speed:	10.7m/s				
Current direction:	42.7deg.	Current speed:	0.4knot				
Time* (UTC)	Depth (m)	Wire Length (m)	Latitude	Longitude	Tension (ton)	Wire speed (m/s)	Wire in/out (↑/↓)
Start the operation							
0:31	-	-			-	-	-
MC on surface, Reset the wire length. Wire out (~1.0m/s)							
0:33	2123	0	76°00.5645' N	174°58.6815' W	0.4	0.0	-
Start the swell compensator. Wire out (~1.0m/s)							
0:43	2122	500			0.9	0.0	-
0:51	2124	1000			1.3	1.0	↓
0:59	2122	1500			1.7	1.0	↓
1:07	2121	2000			2.1	1.0	↓
1:09	2121	2090			2.3	0.0	-
1:13	2124	2090			2.3	~0.3	↓
MC hit the bottom, Wire out 5m							
1:14:23	2121	2116	76°00.5320' N	174°58.7420' W	Min. 1.7	0.3	↓
Wire stop. Wait 10 seconds							
1:15	2120	2121			1.7	0.0	-
Wire in							
1:15	2120	2121			1.7	~0.3	↑
MC left the bottom** Wire in (~1.0m/s)							
1:16:53	2121	2109	76°00.5312' N	174°58.7370' W	Max. 3.1	0.3	↑
1:19	2122	2000			2.4	1.0	↑
1:27	2121	1500			2.0	1.0	↑
1:35	2123	1000			1.5	1.0	↑
Stop the swell compensator. Wire in (~1.0m/s)							
1:46	2123	500			0.9	0.0	-
MC on surface							
1:55	2124	0	76°00.5827' N	174°58.6285' W	0.6	0.4	↑
MC on deck							
1:57	-	-			-	-	-

*LST: UTC -8h

**Latitude and Longitude was used the ship's position.

Table 4.15-7. Observation log of MCst126.

Cruise Name: MR10-05_Leg2 Operator: Yuki Miyajima (MWJ)
 Date: (UTC) 2010/10/3
 Core Number: MCst126
 Area: Northwind Abyssal Plain (NAP)
 Sampling Site: St.126

Weather: Snow
 Wind direction: 138deg. Wind speed: 6.0m/s
 Current direction: 226.9deg. Current speed: 0.4knot

Time* (UTC)	Depth (m)	Wire Length (m)	Latitude	Longitude	Tension (ton)	Wire speed (m/s)	Wire in/out (↑/↓)
Start the operation							
16:09	-	-			-	-	-
MC on surface, Reset the wire length. Wire out (~1.0m/s)							
16:10	1973	0	75°00.0742' N	162°00.5078' W	0.4	0.0	-
Start the swell compensator. Wire out (~1.0m/s)							
16:21	1973	500			0.9	0.0	-
16:30	1974	1000			1.2	1.0	↓
16:38	1973	1500			1.7	1.0	↓
Wire stop.							
16:46	1973	1940			2.2	0.0	-
Wire out.							
16:49	1973	1940			2.2	~0.3	↓
MC hit the bottom, Wire out 5m							
16:51:17	1973	1968	75°00.0316' N	162°00.2932' W	Min. 1.5	0.3	↓
Wire stop. Wait 10 seconds							
16:51	1973	1972			1.7	0.0	-
Wire in							
16:52	1972	1973			1.7	~0.3	↑
MC left the bottom** Wire in (~1.0m/s)							
16:52:42	1972	1965	75°00.0310' N	162°00.2942' W	Max. 3.1	0.3	↑
17:01	1974	1500			1.9	1.0	↑
17:09	1973	1000			1.5	1.0	↑
Stop the swell compensator. Wire in (~1.0m/s)							
17:18	1974	500			0.9	0.0	-
MC on surface							
17:30	1974	0	74°59.9830' N	162°00.1005' W	0.6	0.2	↑
MC on deck							
17:32	-	-			-	-	-

*LST: UTC -8h

**Latitude and Longitude was used the ship's position.

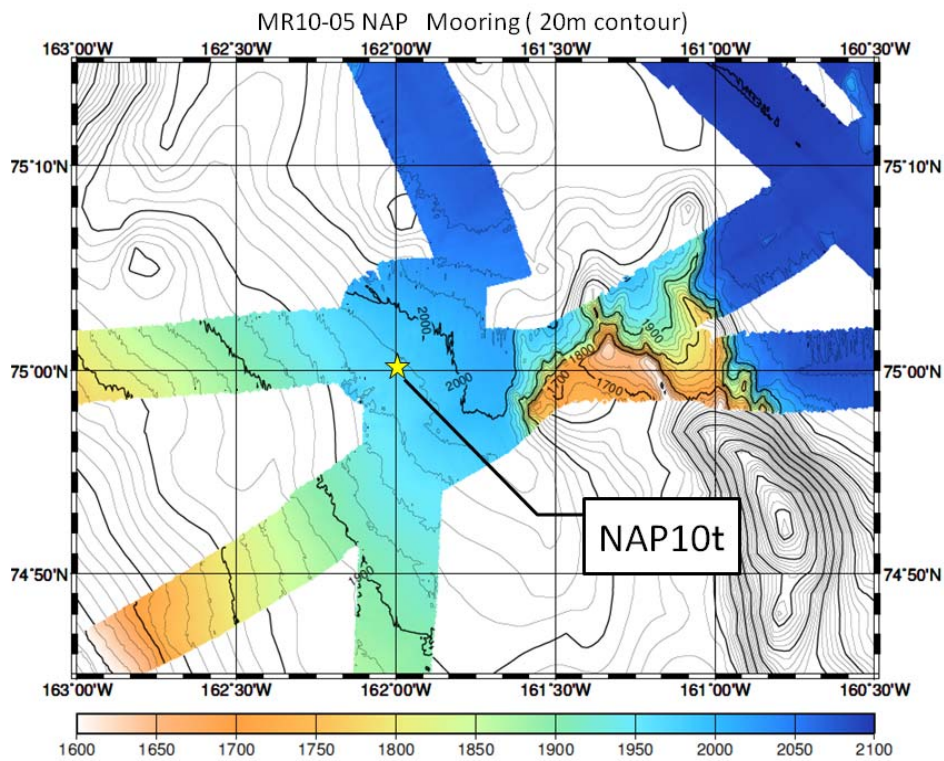
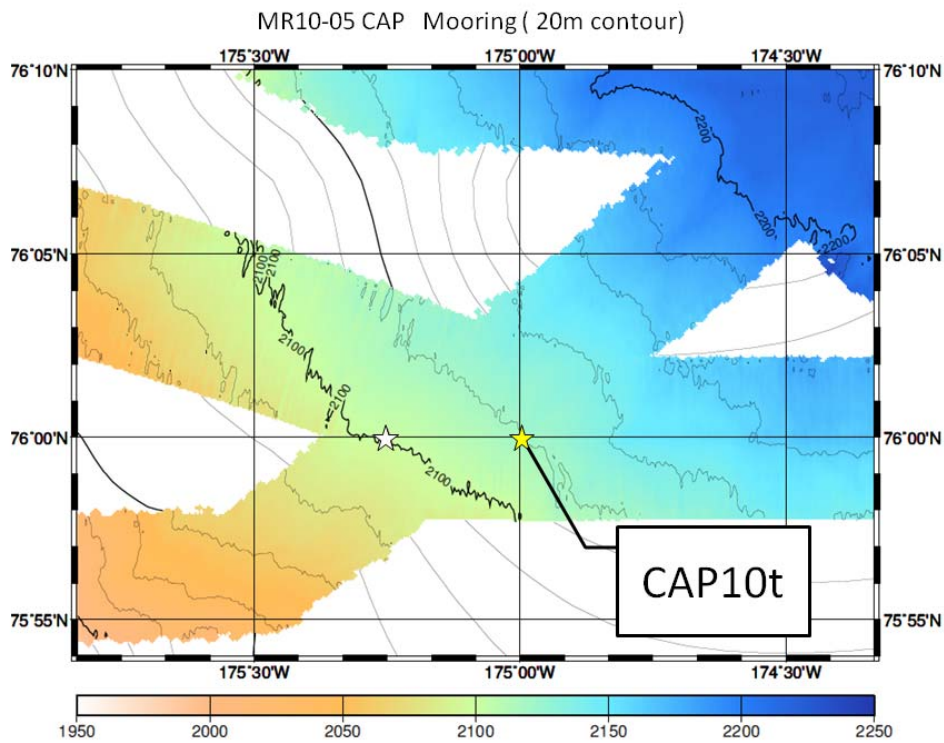

Figure 4.15-1. Bathymetric profiles by SEA BEAM 2100 Multi Beam Bathymetric Survey System around sediment trap stations CAP10t and NAP10t. Background contours were drawn by the data of the International Bathymetric Chart of Arctic Ocean (IBCAO).



Figure 4.15-2. Acoustic release lashed to CTD frame for the response test of acoustic release in deep sea.

Station CAP10t

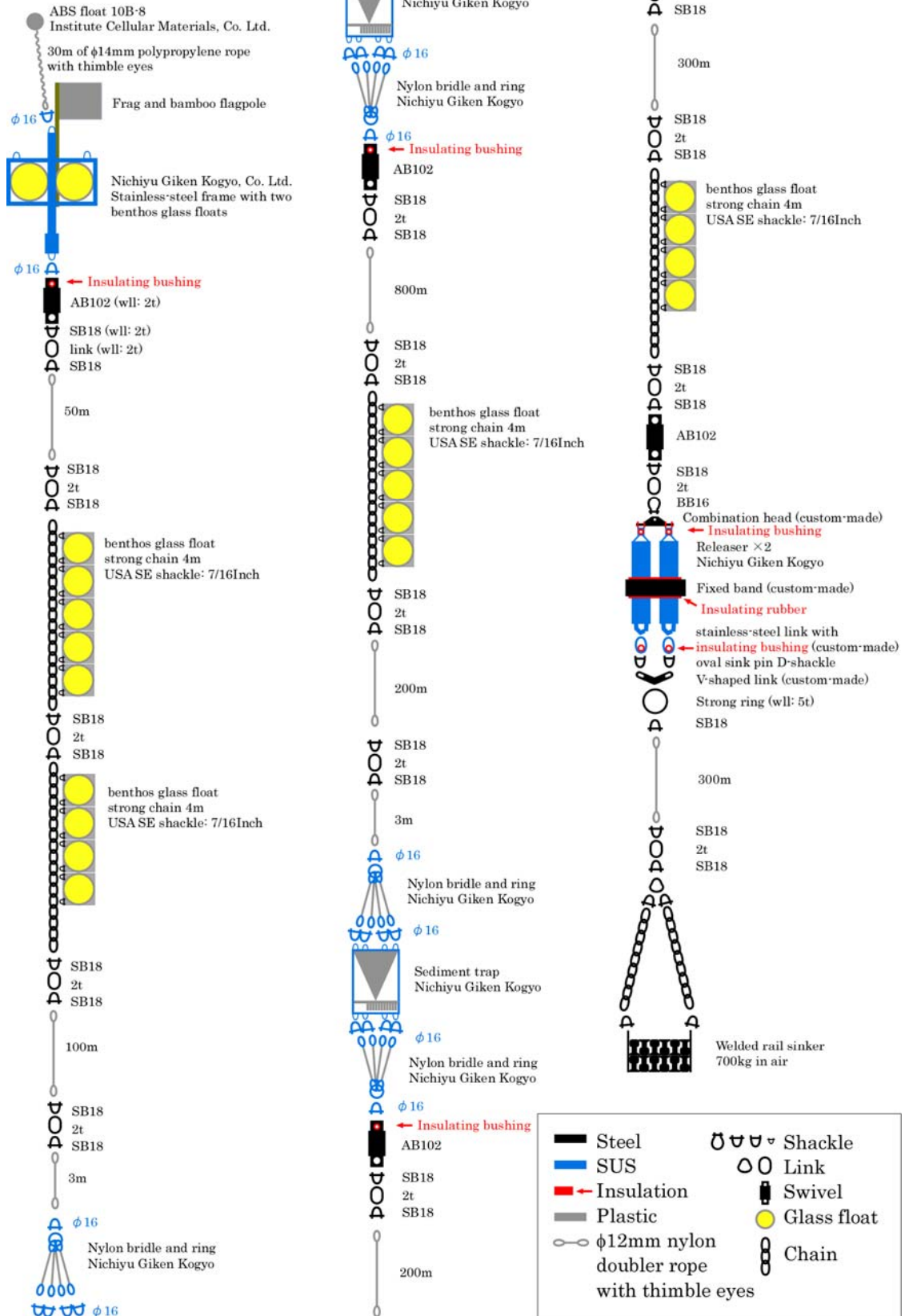

Figure 4.15-3. The layout of sediment trap mooring at Station CAP10t.

Station NAP10t

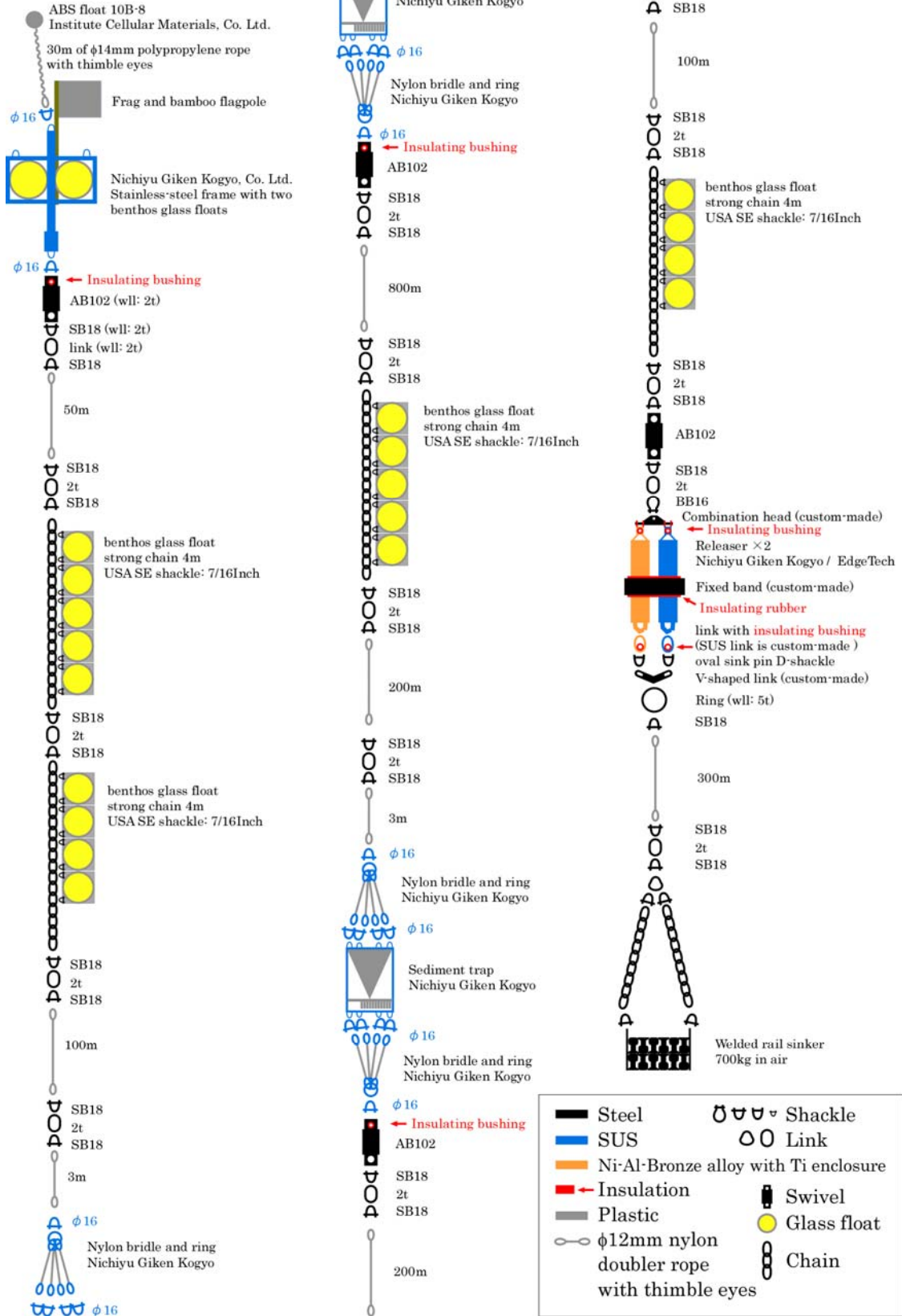

Figure 4.15-4. The layout of sediment trap mooring at Station NAP10t.



Figure 4.15-5. Photographs of MCst39 HAND 8 W (F5.6, 1/20).



Figure 4.15-6. Photographs of MCst126 HAND 8 W (F7.1, 1/10).

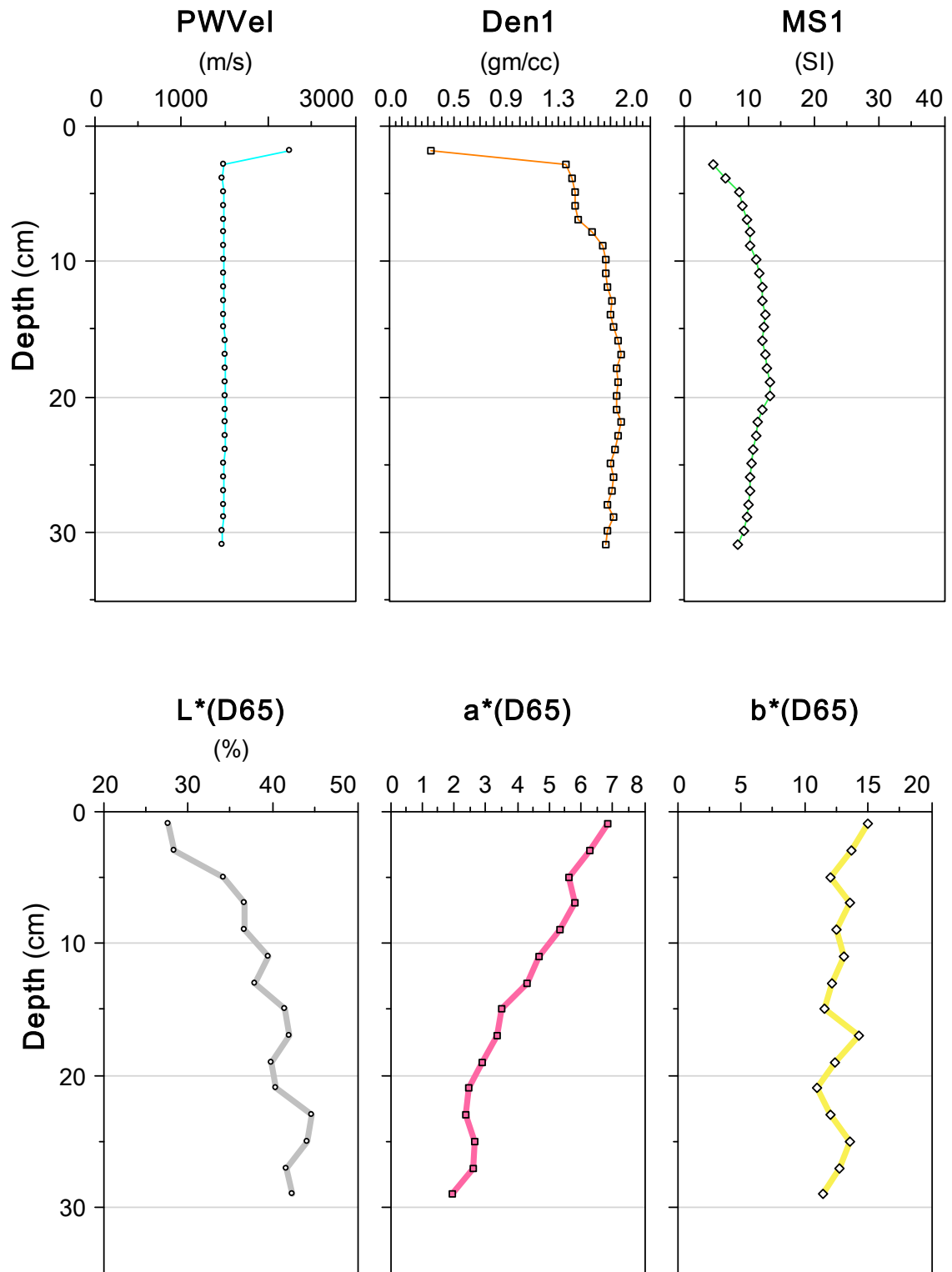

Figure 4.15-7. The MSCL and color reflectance of MCst39 HAND 8. PWVel: P-wave velocity; Den: Density; MS: Magnetic susceptibility.

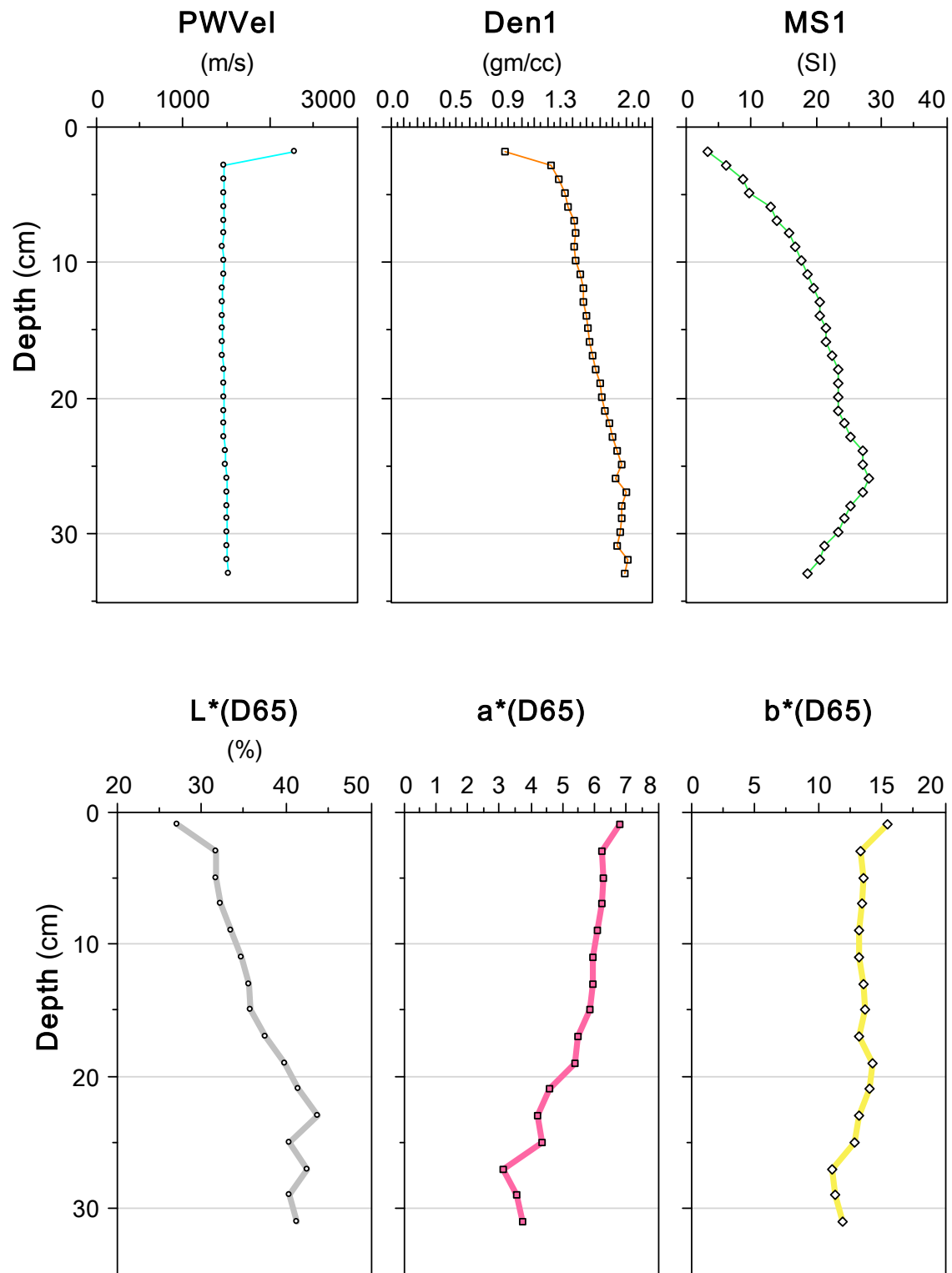

Figure 4.15-8. The MSCL and color reflectance of MCst126 HAND 8. PWVel: P-wave velocity; Den: Density; MS: Magnetic susceptibility.



Figure 4.15-9. soft X-ray photograph of MCst39 HAND 8.



Figure 4.15-10. soft X-ray photograph of MCst126 HAND 8.

Visual Description Sheet

Expedition : MR10-05

Date : 2010. 9. 22

Core : MC st. 039

Sect. : HAND 8

Core Length : 29.5cm

Observer : Stephan Rella

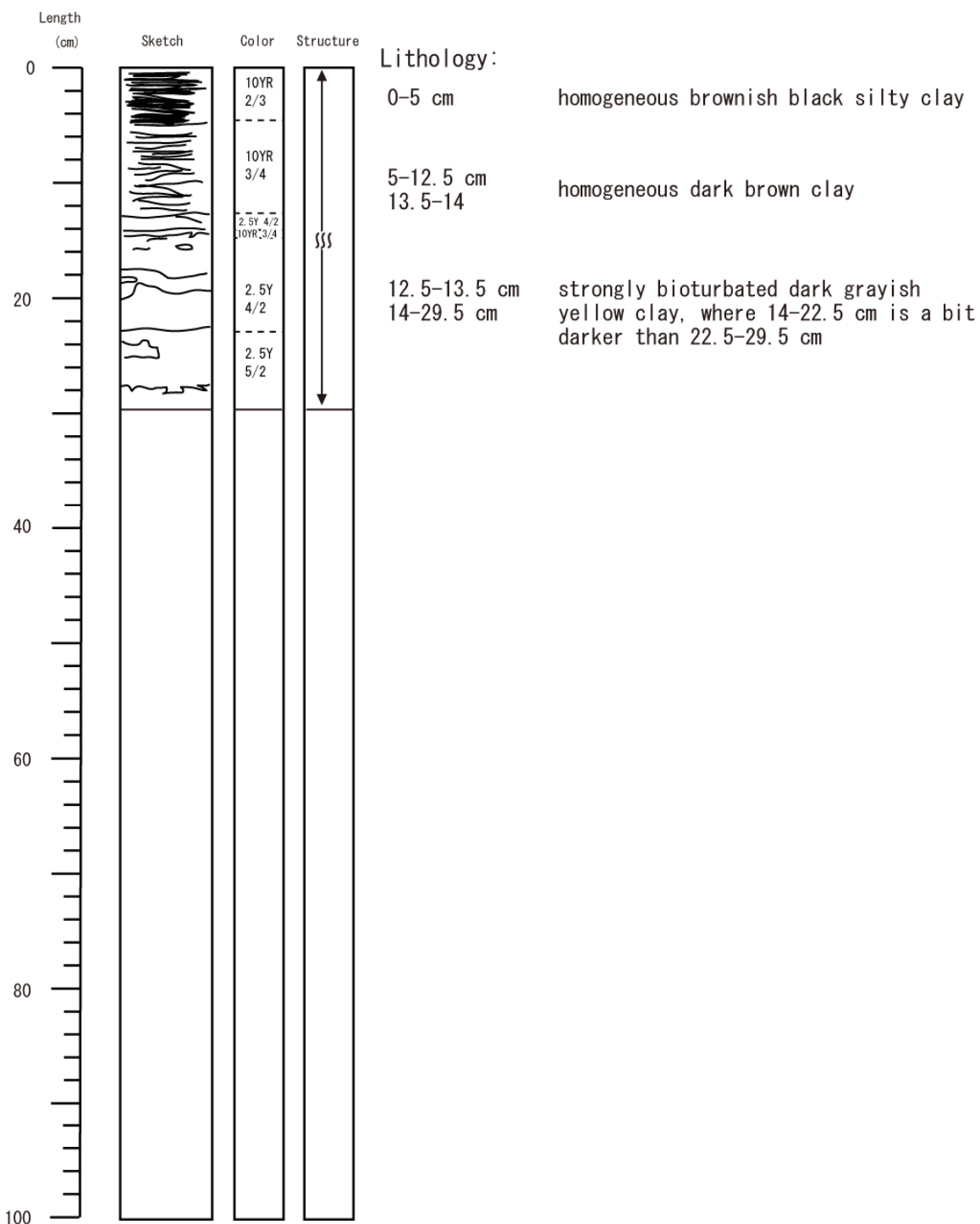

Figure 4.15-11. Visual description of MCst39 HAND 8.

Visual Description Sheet

Expedition : MR10-05

Date : 2010.10.5

Core : MC st.126 Sect. : HAND8 Core Length : 32.7cm

Observer : Tstsuya Shinozaki

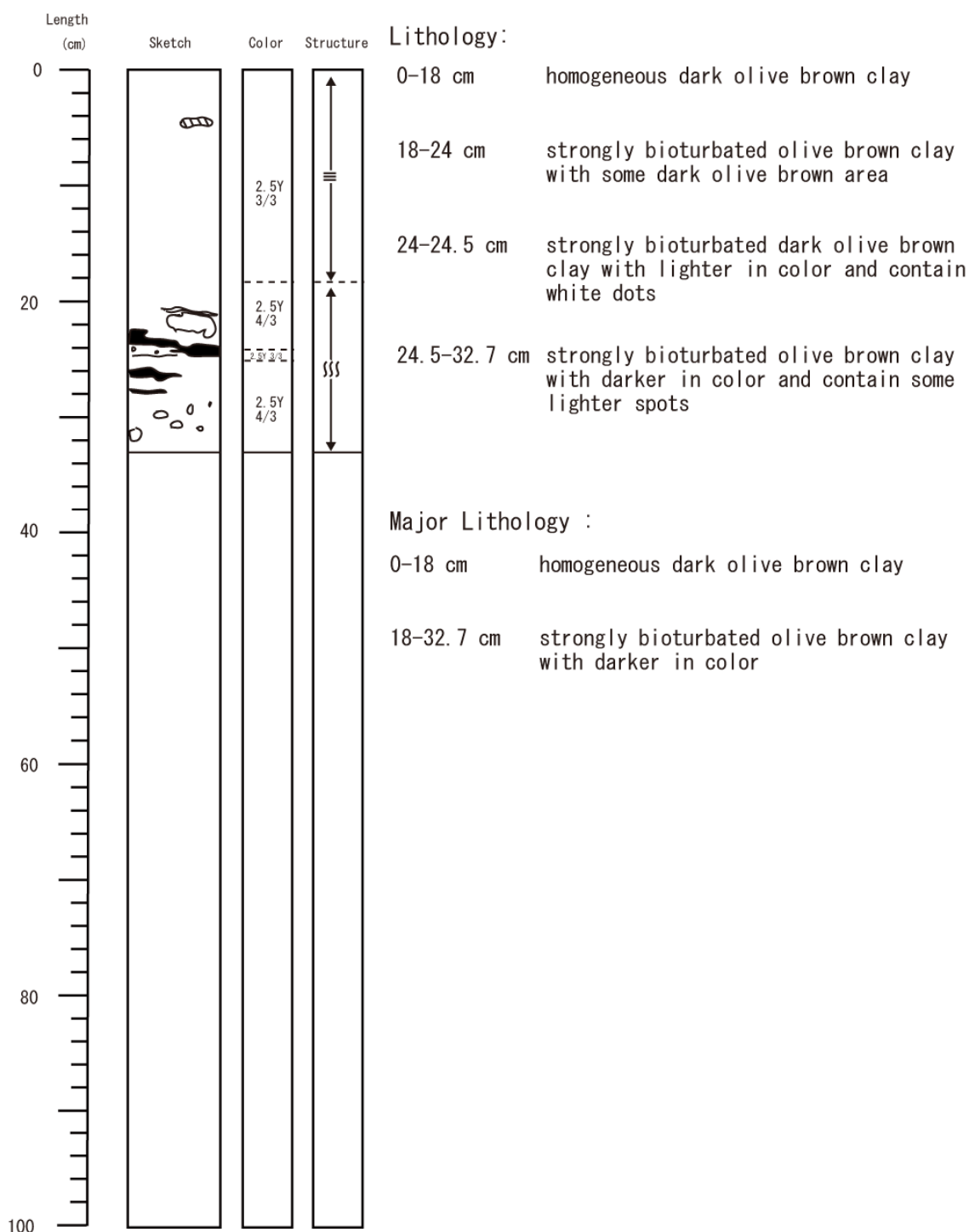

Figure 4.15-12. Visual description of MCst126 HAND 8.

5. Geological Observation

5.1 Sediment core sampling

(1) Personnel

Masao Uchida (National Institute for Environmental Studies; NIES): Principal Investigator

Motoo Utsumi (University of Tsukuba)

Stephan Rella (NIES)

Tetsuya Shinozaki (University of Tsukuba)

Yusuke Sato (MWJ)

Yasushi Hashimoto (MWJ)

Yuki Miyajima (MWJ)

Norio Nagahama (GODI)

Satoshi Okumura (GODI)

(2) Objectives

The Arctic Ocean is sensitive to climate change. For example, during the last glacial maximum sea level was lowered by ~125 m. The size of Bering, Chukchi and Beaufort Seas increased dramatically, and the flow of fresher, nutrient rich Pacific water into the Chukchi Sea was cut off due to the resulting emergence of the Bering Strait. These conditions affected the Arctic climate, especially during the warming interglacial periods, the fresh water budget of the Arctic Ocean, and ocean circulation as they changed through time, but exactly how is not understood. Very little high-resolution proxy data reconstructing sea surface conditions such as biological productivity and sea ice existence and ocean circulation during past climate are very sparse. In this study, we try to reconstruct ocean conditions on past warm periods such as the medieval warm period (0.1ka), the last deglaciation (10-18 ka) and the interstadial periods (125 ka). On these periods, it is clear that the ocean exerts tremendous control over Arctic climate through its temperature, salinity, ice extent, albedo, and sea level. Yet the history of these variables in the Arctic Ocean including the Chukchi Borderland is not known well enough to integrate with the evidence for terrestrial climate change.

On the basis of observations and theoretical considerations, we have come to realize that the Arctic region plays an important role in past global climate change in the Quaternary. The purposes of this cruise are as follows;

- a. to investigate past surface sea temperature using several paloproxies such as

marine phytoplankton moleculars (biomarkers) and archaeal compounds preserved in sediments.

- b. to investigate past ocean circulation using several paleoproxies such as stable carbon isotopes and radiocarbon signatures of planktonic and benthic foraminifera and others.
- c. to investigate relationships between past climate changes and methane release which is widely distributed in continental shelf in Arctic Ocean.
- d. to investigate fate, preservation, and transport of terrestrial organic matter in marine sediment and relationships with climate change using molecular-level terrestrial organic matter properties.
- e. to investigate variations of diversity of planktonic and benthic foraminifera associated with climate change.
- f. to develop radiocarbon and foraminiferal oxygen isotope based age model over last interglacial's-glacial periods.

(3) Parameters

Piston corer system (PC)

Piston corer system consists of weight, 5m-long duralumin barrel with polycarbonate liner tube and a pilot core sampler. Inner diameter (I.D.) of duralumin barrel is 80mm, polycarbonate liner tube is 74mm respectively. We used a small multiple corer (“Ashura”) for a pilot core sampler. The total weight of the system is approximately 1.5t.

In this cruise, we choose two coring methods “Inner method” and “Outer method”. “Inner method” is use duralumin barrel with polycarbonate liner tube. “Outer method” is use only duralumin barrel.

At Inner method, Piston was selected “Rubber Plate Piston” (“RPP”) that is composing of stainless body and rubber plates. Another method, piston was used normal type that is composing of stainless body and four O-rings (size: P67).

Coring method, Corer weight and total barrel length were decided by site survey data. Each specification is shown in Figure.

Table. 5.1-1. Specific of Piston Corers

Core ID	Method	Barrel length(m)	Weight(t)	Piston type*
PC01	Inner	15	1.2	RPP70*2+50*2
PC02	Inner	15	1.2	RPP70*3
PC03	Inner	10	0.9	RPP70*3
PC04	Outer	15	1.5	Normal
PC05	Inner	10	0.9	RPP50*2

*RPP (Number of rubber plate)

Multiple corer (MC)

A Multiple core sampler was used for taking the surface sediment. This core sampler consists of a main body of 640kg-weight and 8 sub-core samplers (I.D. 74mm and length of 60cm) in which one was polycarbonate liner tube for physicality analysis and visual core description(VCD).

(4) Instruments and methods

Winch operation

When we started lowering PC, a speed of wire out was set to be 0.2 m/s., and then gradually increased to the maximum of 1.0 m/s. The corers were stopped at a depth about 100 m above the seafloor for 2-3 minutes to reduce some pendulum motion of the system. After the corers were stabilized, the wire was stored out at a speed of 0.3 m/s., and we carefully watched a tension meter. When the corers touched the bottom, wire tension abruptly decreases by the loss of the corer weight. Immediately after confirmation that the corers hit the bottom, wire out was stopped and winding of the wire was started at a speed of 0.3m/s., until the tension gauge indicates that the corers were lifted off the bottom. After leaving the bottom, winch wire was wound in at the maximum speed.

MSCL measurements

A GEOTEK multi-sensor core logger (MSCL) has three sensors, which is gamma-ray attenuation (GRA), P-wave velocity (PWV), and magnetic susceptibility (MS). There were measured on whole-core section before splitting using the onboard MSCL. These data measurement was carried on every 1 or 2cm.

GRA was measured a gamma-ray source and detector. These mounted across the core on a sensor stand that aligns them with the center of the core. A narrow beam of gamma-ray is emitted by Caesium-137 (^{137}Cs) with energies principally at 0.662MeV. Also, the photon of gamma-ray is collimated through 5mm diameter in rotating shutter at the front of the housing of ^{137}Cs . The photon passes through the core and is detected on the other side. The detector comprises a scintillator (a 2" diameter and 2" thick NaI crystal).

GRA calibration assumes a two-phase system model for sediments, where the two phases are the minerals and the interstitial water. Aluminum has an attenuation coefficient similar to common minerals and is used as the mineral phase standard. Pure water is used as the interstitial-water phase standard. The actual standard consists of a telescoping aluminum rod (five elements of varying thickness) mounted in a piece of core liner and filled with distilled water. GRA was measured with 10 seconds counting.

MS was measured using Bartington loop sensor that has an internal diameter of 100mm installed in MSCL. An oscillator circuit in the sensor produces a low intensity (approx. 80 A/m RMS) non-saturating, alternating magnetic field (0.565kHz). MS was measured with 1 second.

PWV was measured two oil filled Acoustic Rolling Contact (ARC) transducers, which are mounted on the center sensor stand with gamma system. These transducers measure the velocity of P-Wave through the core and the P-Wave pulse frequency.

CCR measurements

After splitting each section of cores into working and archive halves, archive halves were measured the Core Color Reflectance (CCR), which was the value calculated the spectral reflectance from 400 to 700nm in wavelengths by using the Konica Minolta CM-700d. This device is a compact and hand-held instrument, and can measure spectral reflectance of sediment surface with a scope of 8mm diameter. To ensure accuracy, the CM-700d was used with a double-beam feedback system, monitoring the illumination on the specimen at the time of measurement and automatically compensating for any changes in the intensity or spectral distribution of the light. The CM-700d has a switch that allows the specular component to be include (SCI) or excluded (SCE). We chose setting the switch to SCE. The SCE setting is the recommended mode of operation for sediments in which the light reflected at a certain angle (angle of specular reflection) is trapped and absorbed at the light trap position on the integration sphere.

Calibrations are zero calibration and white calibration before the measurement of core samples. Zero calibration is carried out into the air. White calibration is carried out using the white calibration piece (CM-700d standard accessories) without crystal clear polyethylene wrap. The color of the split sediment (Archive half core) was measured on every 2cm through crystal clear polyethylene wrap.

There are different systems to quantify the color reference for soil and sediment measurements, the most common is the $L^*a^*b^*$ system, also referred to as the CIE (Commission International d'Eclairage) LAB system. It can be visualized as a cylindrical coordinate system in which the axis of the cylinder is the lightness variable L^* , ranging from 0% to 100%, and the radii are the chromaticity variables a^* and b^* . Variable a^* is the green (negative) to red (positive) axis, and variable b^* is the blue (negative) to yellow (positive) axis. Spectral data can be used to estimate the abundance of certain components of sediments.

Core Photographs

After splitting each section of cores into working and archive halves, sectional photographs of working were taken using a digital camera (Camera body: Nikon D1x / Lens: Nikon AF Zoom-Nikkor 24-50mm). When using the digital camera, shutter speed was 1/40 ~ 1/10 sec, F-number was 4.5 ~ 7.6, sensitivity was ISO 125. File format of raw data is Exif-JPEG. Details for settings were included on property of each file. After choosing different exposure photographs, white correction was carried out using by the editing software (Adobe Photoshop Elements 6.0).

Soft-X ray photographs

Soft-X ray photographs were taken to observe sedimentary structures of cores. Sediment samples were put into the original plastic cases (200x3x7mm) from cores. Each case has a TEPURA seal showing cruise code, core number, section number, case number, and section depth (cm). Each case was rimmed by PARAFILM to seal the sediment.

Soft-X ray photographs were taken to using the device SOFTEX PRO-TEST 150 on board. The condition of X-ray was decided from results of test photographs by each core section. The condition was ranged between 45~50KVp, 1.5~2mA, and 140~200 seconds. All photographs were developed into the negative films by the device FIP-1400 on board.

The negative films were scanned by Epson Offirio ES-10000G to digital image files. The file quality was 300dpi and the file format was TIFF. Afterward the images were carried out histogram coordination.

In this cruise, the total 272 sediment sample cases were collected from cores, and the total 71 negative films were taken X-ray photograph and developed. These results will be stored at JAMSTEC, NIES and Hokkaido University.

(5) Results

Piston Corer (PC)

PC core were collected on the off Barrow and the Northwind Ridge. Coring site is shown in Figure 5.1-1. Results of the PC are summarized in table 5.1-2.

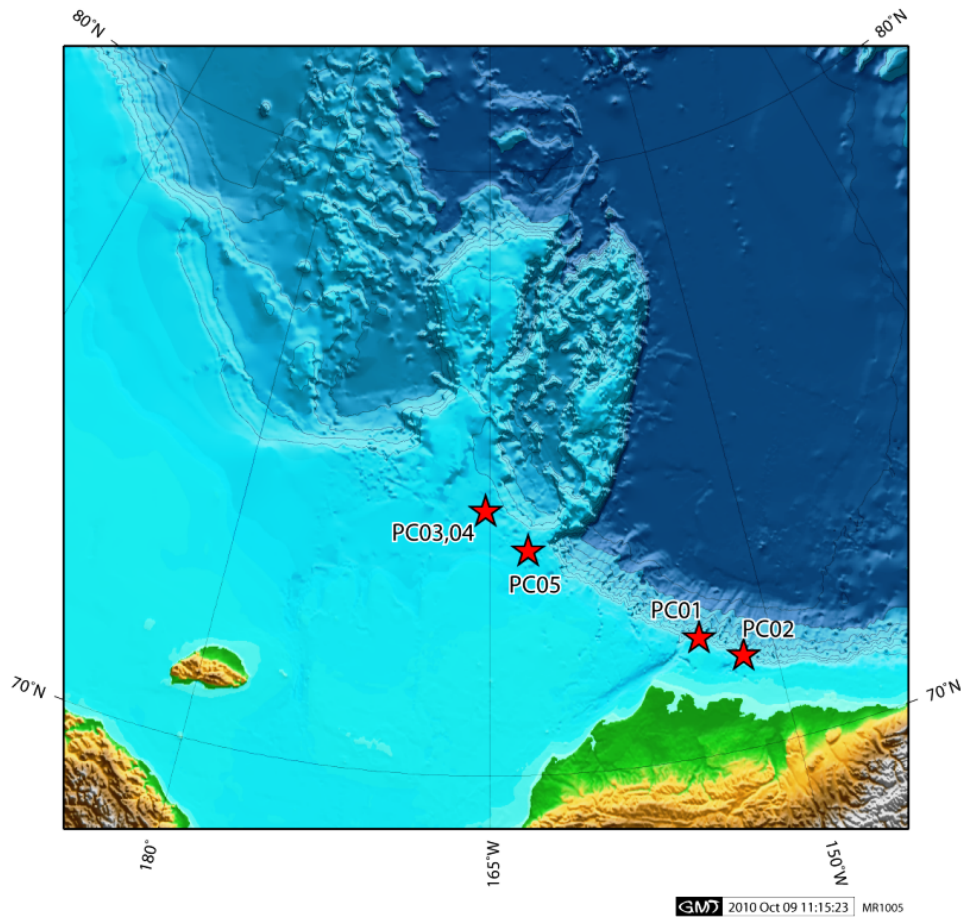

Figure 5.1-1. PC coring sites

Table 5.1-2. Coring summary of the PC.

Core ID	Date (mmddyy)	Latitude (°)	Longitude (°)	Depth (m)	Core length (cm)	remarks
PC01	2010/9/9	71-57.3080N	153-46.6047W	408	1392.3	Pipe 15m. Inner type.
PC02	2010/9/9	71-31.6027N	151-40.2630W	1,195	1425.0	Pipe 15m. Inner type.
PC03	2010/10/2	74-22.5129N	165-14.9554W	356	534.7	Pipe 10m. Inner type.
PC04	2010/10/2	74-22.5055N	165-14.8974W	356	768.0	Pipe 15m. Outer type. Flow-in 7.6m.
PC05	2010/10/6	73-42.5695N	162-44.5633W	203	607.0	Pipe 10m. Inner type.

Multiple Corer (PC)

MC Coring site are shown in Figure 5.1-2. Results of the MC are summarized in table 5.1-3. MC01 core were collected on site of PC01.

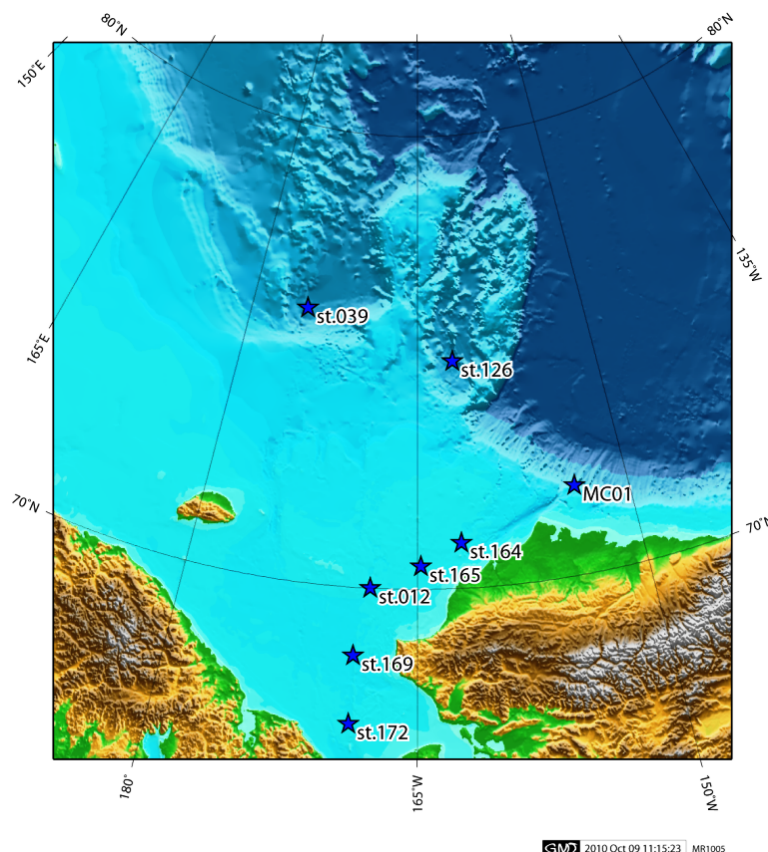

Figure 5.1-2 MC coring sites

Table 5.1-3. Coring summary of the MC.

Core ID	Date (mmddy)	Latitude (°)	Longitude (°)	Depth (m)	Core length (cm)*	Remarks
MCst12	2010/9/5	69-59.99N	167-59.99W	49	14.0	
MC01	2010/9/9	71-57.30N	153-46.69W	408	25.0	
MC02	2010/9/9	71-31.60N	151-40.43W	1,191	0	Coring is failed(Sediment is too soft).
MCst39	2010/9/18	76-00.53N	174-58.74W	2,121	29.5	
MCst126	2010/10/3	75-00.0316N	162-00.2932W	1,972	32.7	
MCst164	2010/10/11	70-59.9760N	161-59.9109W	45	18.0	
MCst165	2010/10/11	70-29.7977N	164-45.7460W	44	20.0	
MCst169	2010/10/12	68-29.9690N	168-49.9173W	53	26.5	
MCst172	2010/10/12	67-00.0025N	168-49.9351W	46	24.0	

*All core length described the HAND8

MSCL and CCR data

All results are shown in Figure 5.1-3 ~ 5.1-6.

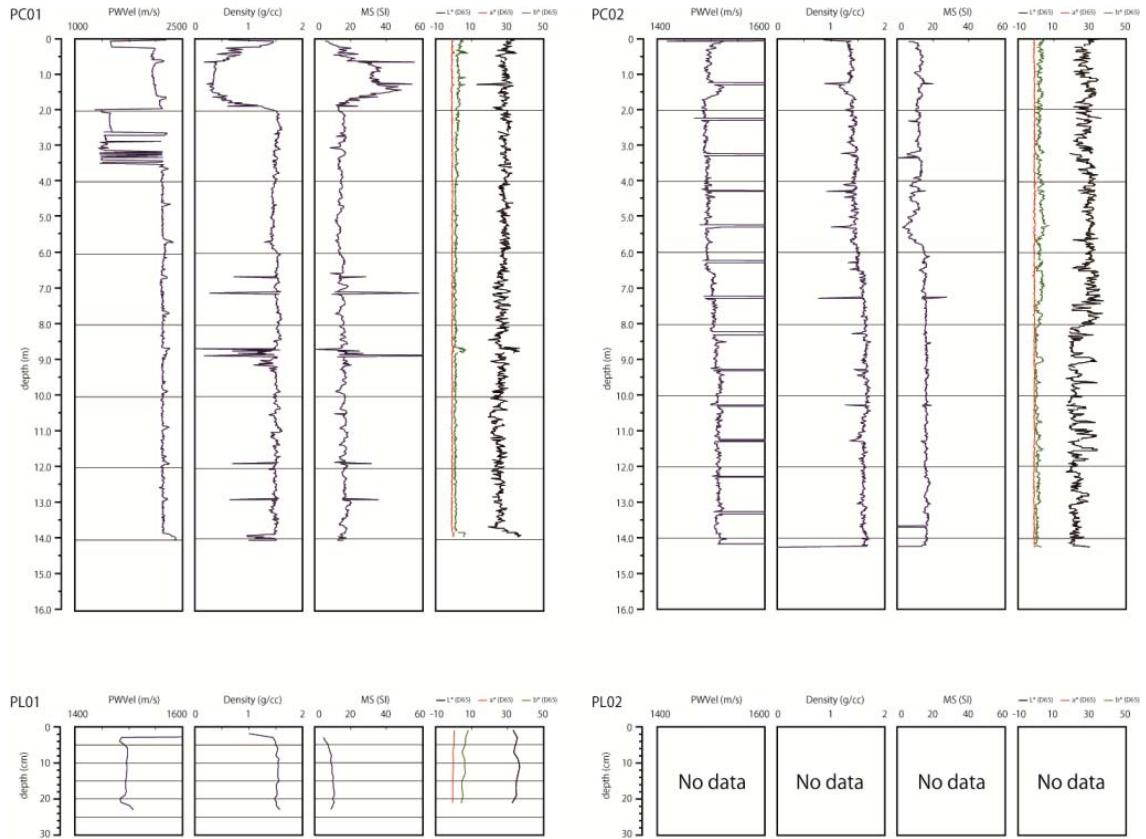

Figure 5.1-3. MSCL and CCR data of PC01, PL01, PC02 and PL02.

PWVel: P-wave velocity, MS: Magnetic susceptibility.

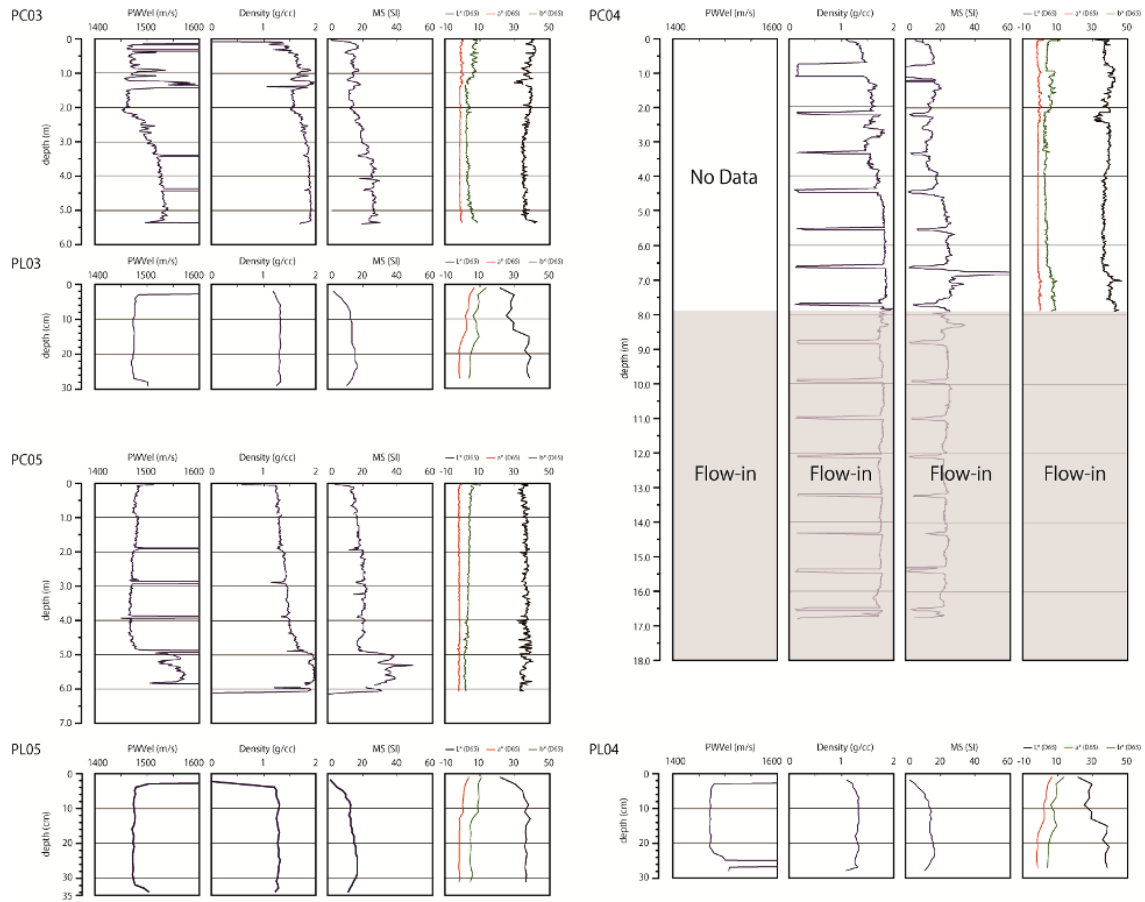

Figure 5.1-4. MSCL and CCR data of PC03, PL03, PC04, PL04, PC05 and PL05.

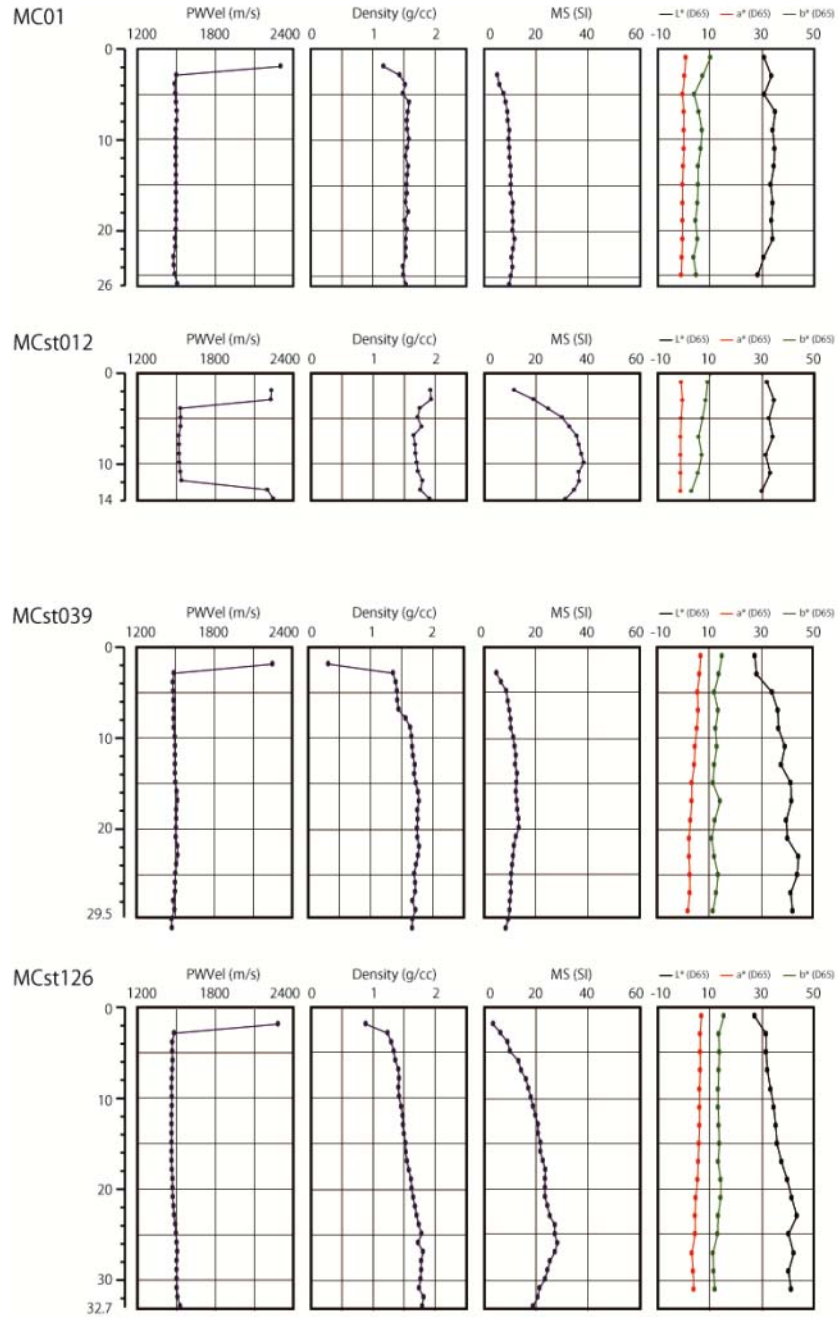

Figure 5.1-5. MSCL and CCR data of MC01, MCst012, MCst039 and MCst126.

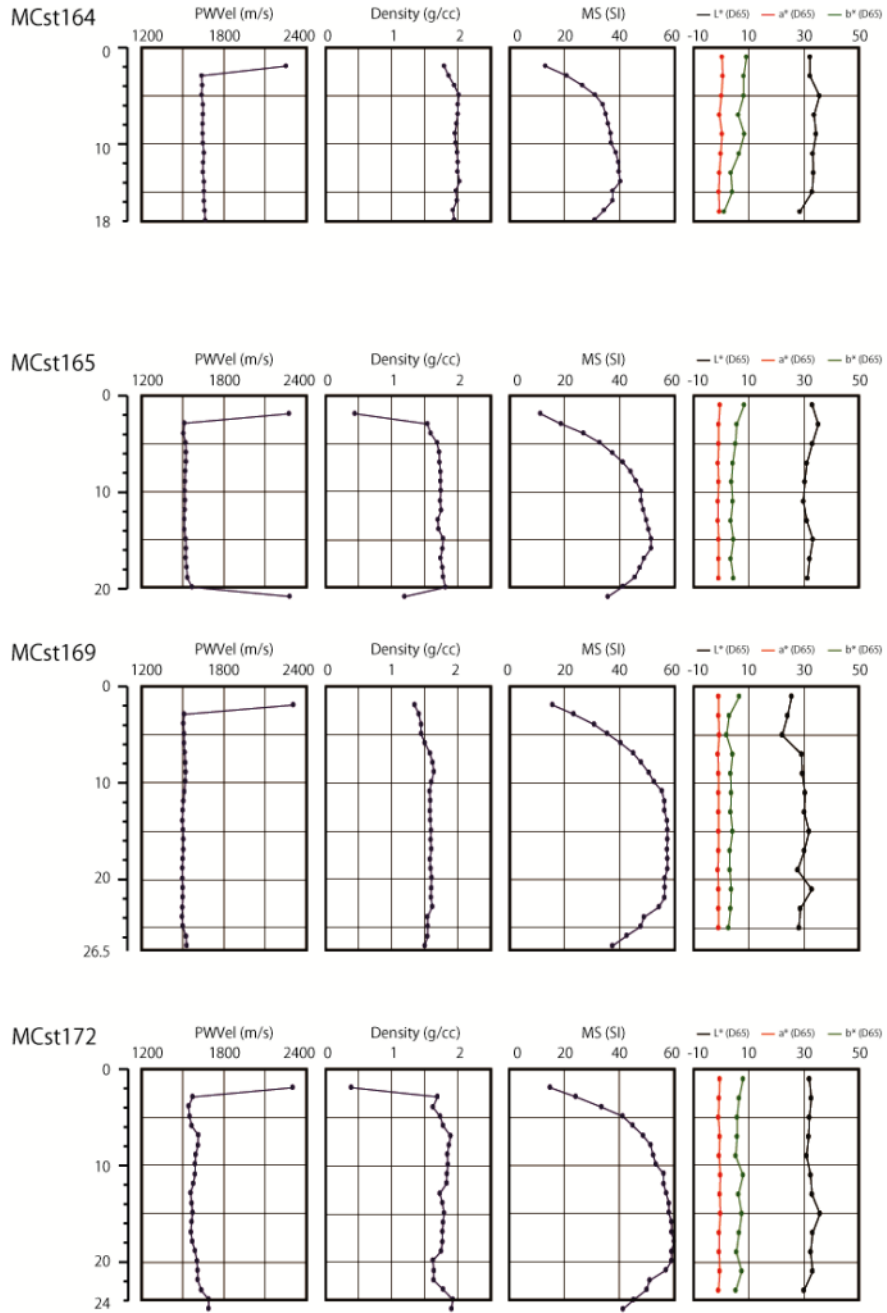

Figure 5.1-6. MSCL and CCR data of MCst164, MCst165, MCst169 and MCst172.

Core Photographs

Photographs of each core are shown in Figure 5.1-7 ~ 5.1-15.

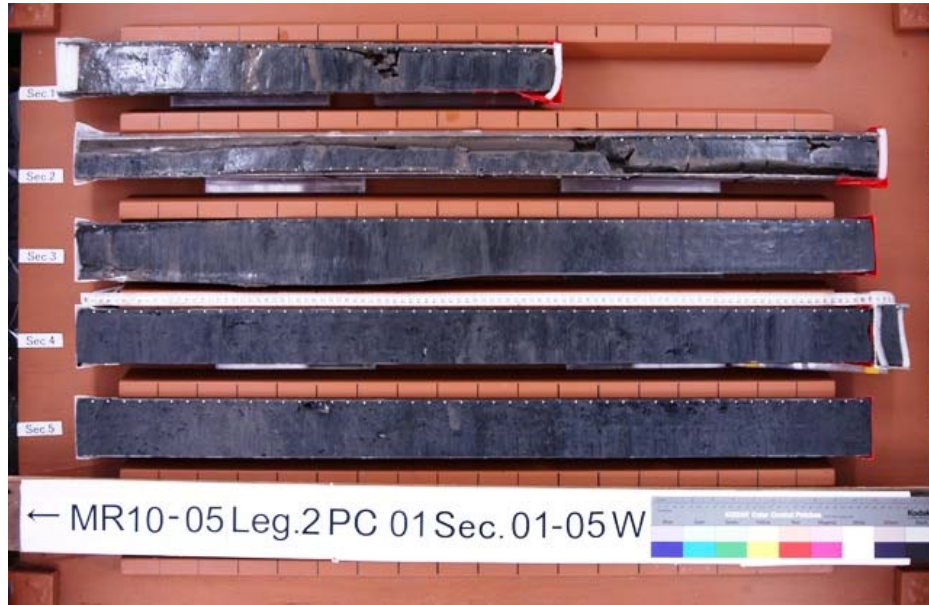

Figure 5.1-7. Photographs of W-half core PC01 sec.01 – 10.

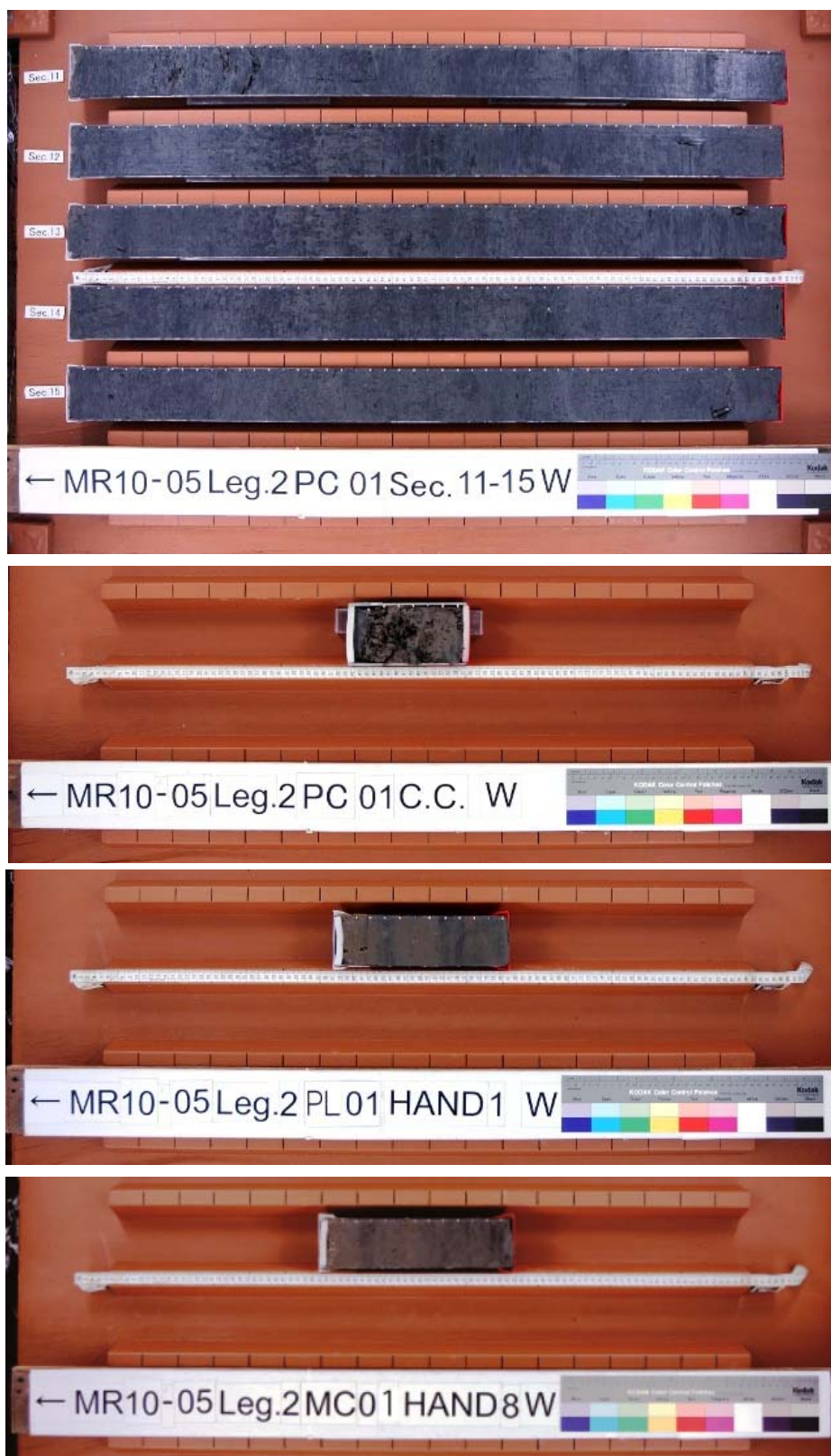

Figure 5.1-8. Photographs of W-half core PC01 sec.11 – 15, PC01 C.C., PL01 HAND1 and MC01 HAND8. C.C.: Core Catcher

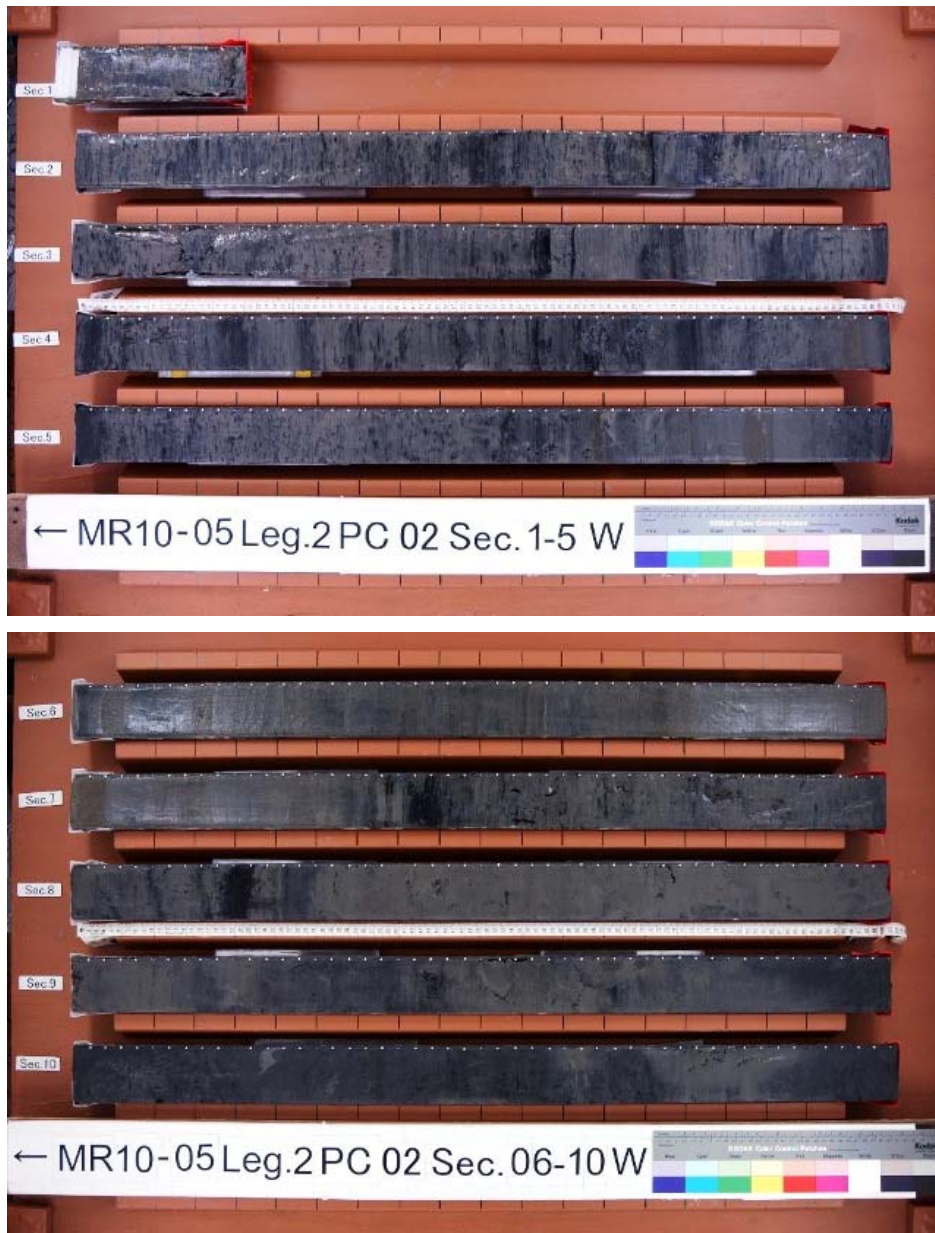

Figure 5.1-9. Photographs of W-half core PC02 sec.01 – 10.



Figure 5.1-10. Photographs of W-half core PC02 sec.11 – 15 and PC02 C.C..

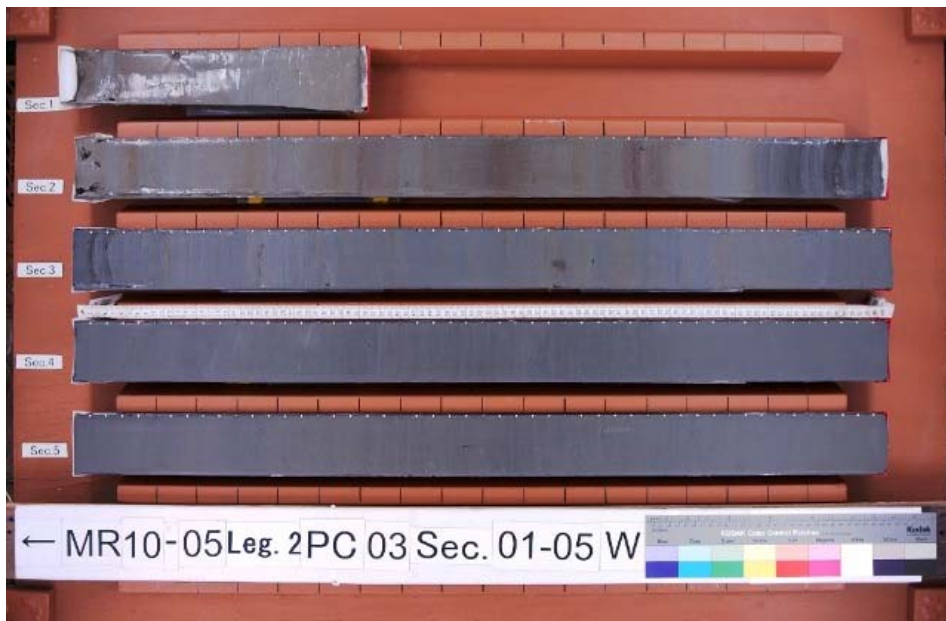

Figure 5.1-11. Photographs of W-half core PC03 sec.01 – 06 and PL03 HAND3.

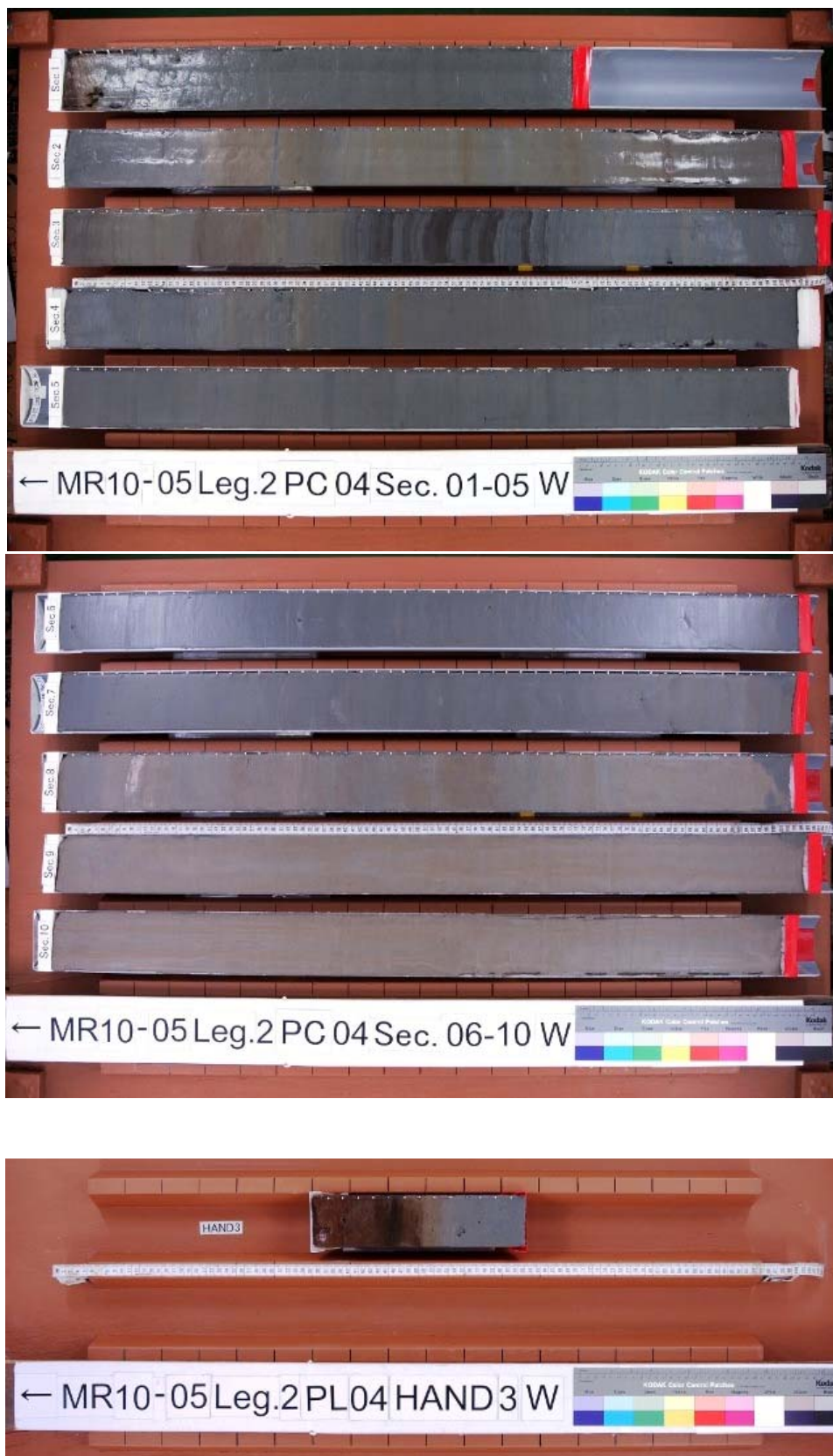

Figure 5.1-12. Photographs of W-half core PC04 sec.01 – 10 and PL04 HAND3.

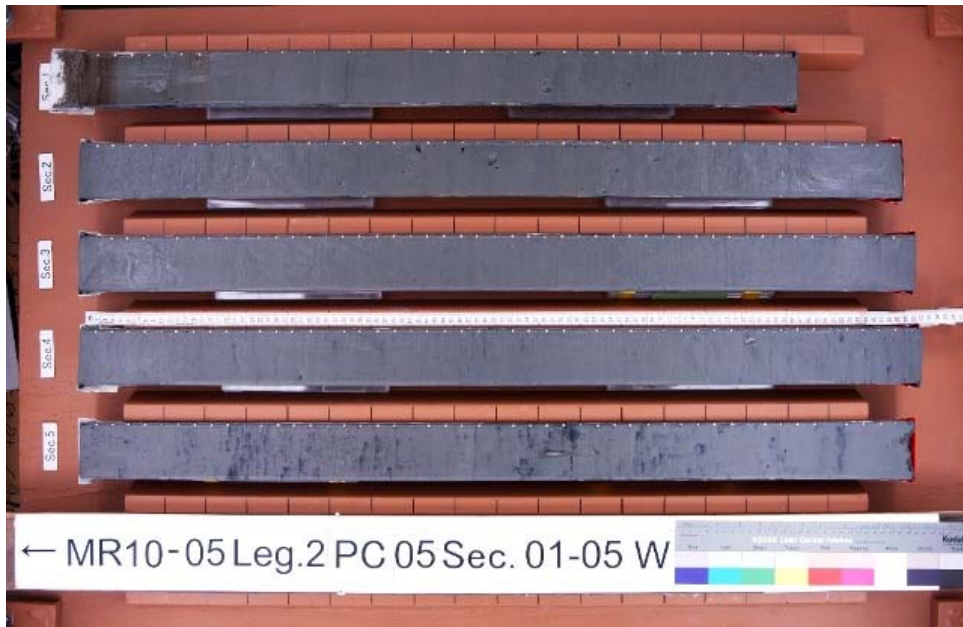

Figure 5.1-13. Photographs of W-half core PC04 sec.01 – 6, PC05 C.C. and PL05 HAND3.



Figure 5.1-14. Photographs of W-half core MCst.012, MCst.039, MCst.126 and MCst.164.



Figure 5.1-15. Photographs of W-half core MCst.165, MCst.169 and MCst.172.

Soft X-ray Photographs

In this cruise, the total 134 sediment sample cases were collected from cores, and the total 61 negative films were taken X-ray photograph and developed. These results will be stored at NIES

(6) Observation log

Observation logs are shown in table 5.1-4 ~ 5.1-16

Table 5.1-4. Observation log of the PC01

Cruise Name:	MR10-05_Leg2	Operator:	Yusuke Sato (MWJ)
Date: (UTC)	2010/9/9	Pilot Number:	PL01
Core Number:	PC01		
Area:	Barrow Canyon		
Sampling Site:	St.PC01		
Corer type:	Inner type piston corer	Pilot type:	Ashura
Pipe length:	15m	Pilot weight:	100kg
Main wire length:	23.3m	Pilot wire length:	24.0m
Free fall:	5.1m		
Weather:	Fog	Wave height:	1.0m
Wind direction:	5.4deg.	Wind speed:	5.7m/s
Current direction:	78.3deg.	Current speed:	0.8knot

Time* (UTC)	Depth (m)	Wire length (m)	Latitude	Longitude	Tension (ton)	Wire speed (m/s)	Wire in/out (↑/↓)	Remarks
16:55	-	-			-	-	-	Start the operation
17:20	-	-			-	-	-	Connect Ashura corer
17:22	405	0	71°57.2985' N	153°46.7346' W	1.3	0.0	-	PC (balance) on surface, Reset the wire length. Wire out (~0.3m/s)
17:26	408	50			1.3	0.0	-	Attach a transponder (10in.). Wire out (~1.0m/s)
17:33	407	200			1.4	0.0	-	Start the swell compensator. Wire out (~1.0m/s)
17:36	407	330			1.5	0.0	-	Stop the wire out (to stabilize the PC)
17:41	406	330			1.5	~0.3	↓	Wire out
17:44:22	408	384	71°57.3080' N	153°46.6047' W	Min. 0.1	0.3	↓	PC hit the bottom, wire in**
			71°57.3044' N	153°46.7487' W				
17:45:50	408	361	71°57.3075' N	153°46.6124' W	Max. 2.7	0.3	↑	PC left the bottom**
			71°57.3037' N	153°46.7485' W				
17:50	411	200			1.5	0.0	-	Stop the swell compensator. Wire in (~1.0m/s)
17:55	408	50			1.4	0.0	-	Remove a transponder (10in). Wire in (~0.5m/s)
17:57	405	0	71°57.3072' N	153°46.7441' W	1.2	0.5	↑	PC (balance) on surface
18:03	-	-			-	-	-	Ashura on deck
18:31	-	-			-	-	-	PC on deck

*LST: UTC -8h

**Latitude and Longitude was used the transponder's position.

Table 5.1-5. Observation log of the PC02

Cruise Name:	MR10-05_Leg2	Operator:	Yusuke Sato (MWJ)
Date: (UTC)	#####	Pilot Number:	PL02
Core Number:	PC02		
Area:	Barrow Canyon		
Sampling Site:	St.PC02		
Corer type:	Inner type piston corer	Pilot type:	Ashura
Pipe length:	15m	Pilot weight:	100kg
Main wire length:	23.3m	Pilot wire length:	24.0m
Free fall:	5.1m		
Weather:	Cloudy	Wave height:	0.6m
Wind direction:	5.7deg.	Wind speed:	5.8m/s
Current direction:	143.2deg.	Current speed:	0.3knot

Time* (UTC)	Depth (m)	Wire length (m)	Latitude	Longitude	Tension (ton)	Wire speed (m/s)	Wire in/out (↑/↓)	Remarks
0:40	-	-			-	-	-	Start the operation
1:03	-	-			-	-	-	Connect Ashura corer
1:07	1193	0	71°31.5628' N	151°40.4609' W	1.2	0.0	-	PC (balance) on surface, Reset the wire length. Wire out (~0.8m/s)
1:11	1191	50			1.2	0.0	-	Attach a transponder (10in.). Wire out (~1.0m/s)
1:17	1192	200			1.3	0.0	-	Start the swell compensator. Wire out (~1.0m/s)
1:23	1194	550			1.7	1.0	↓	
1:31	1196	1000			2.1	1.0	↓	
1:34	1190	1119			2.2	0.0	-	Stop the wire out (to stabilize the PC)
1:36	1195	1120			2.2	~0.3	↓	Wire out
1:39:38	1195	1164	71°31.6027' N	151°40.2630' W	Min. 0.4	0.3	↓	PC hit the bottom, wire in**
			71°31.6072' N	151°40.4106' W				
1:40:00	1193	1145	71°31.6031' N	151°40.2634' W	Max. 2.9	0.3	↑	PC left the bottom**
			71°31.6054' N	151°40.4134' W				
1:45	1192	900			2.1	1.0	↑	
1:52	1195	500			1.7	1.0	↑	
1:59	1192	200			1.4	0.0	-	Stop the swell compensator. Wire in (~1.0m/s)
2:05	1194	50			1.3	0.0	-	Remove a transponder (10in). Wire in (~0.7m/s)
2:07	1195	0	71°31.6096' N	151°40.4839' W	1.2	0.3	↑	PC (balance) on surface
2:12	-	-			-	-	-	Ashura on deck
2:40	-	-			-	-	-	PC on deck

*LST: UTC -8h

**Latitude and Longitude was used the transponder's position.

Table 5.1-6. Observation log of the PC03

Cruise Name: MR10-05_Leg2 Operator: Yusuke Sato (MWJ)
 Date: (UTC) #####
 Core Number: PC03 Pilot Number: PL03
 Area: North wind ridge
 Sampling Site: St.121

Corer type: Inner type piston corer Pilot type: Ashura
 Pipe length: 10m Pilot weight: 100kg
 Main wire length: 17.8m Pilot wire length: 18.0m
 Free fall: 4.1m

Weather: Cloudy Wave height: 1.0m
 Wind direction: 341.0deg. Wind speed: 3.4m/s
 Current direction: 288.0deg. Current speed: 0.5knot

Time* (UTC)	Depth (m)	Wire length (m)	Latitude	Longitude	Tension (ton)	Wire speed (m/s)	Wire in/out (↑/↓)	Remarks
18:19	-	-			-	-	-	Start the operation
18:35	-	-			-	-	-	Connect Ashura corer
18:37	356	0	74°22.5432' N	165°14.8910' W	0.9	0.0	-	PC (balance) on surface, Reset the wire length. Wire out (~0.8m/s)
18:40	358	50			1.0	0.0	-	Attach a transponder (10in.). Wire out (~1.0m/s)
18:47	359	290			1.2	0.0	-	Stop the wire out (to stabilize the PC)
18:50	358	290			1.2	-0.3	↓	Wire out
18:53:21	357	333	74°22.5129' N 74°22.5375' N	165°14.9554' W 165°14.8361' W	Min. 0.1	0.3	↓	PC hit the bottom, wire in**
18:54:27	356	317	74°22.5125' N 74°22.5361' N	165°14.9596' W 165°14.8429' W	Max. 2.7	0.3	↑	PC left the bottom**
19:01	357	50			1.0	0.0	-	Remove a transponder (10in). Wire in (~0.7m/s)
19:03	359	0	74°22.5369' N	165°14.8143' W	1.0	0.3	↑	PC (balance) on surface
19:08	-	-			-	-	-	Ashura on deck
19:29	-	-			-	-	-	PC on deck

*LST: UTC -8h

**Latitude and Longitude was used the transponder's position.

Table 5.1-7. Observation log of the PC04

Cruise Name: MR10-05_Leg2 Operator: Yasushi Hashimoto (MWJ)
 Date: (UTC) #####
 Core Number: PC04 Pilot Number: PL04
 Area: North wind ridge
 Sampling Site: St.121

Corer type: Outer type piston corer Pilot type: Ashura
 Pipe length: 15m Pilot weight: 100kg
 Main wire length: 23.8m Pilot wire length: 24.6m
 Free fall: 5.7m

Weather: Snow Wave height: 1.1m
 Wind direction: 319.0deg. Wind speed: 7.2m/s
 Current direction: 318.0deg. Current speed: 0.5knot

Time* (UTC)	Depth (m)	Wire length (m)	Latitude	Longitude	Tension (ton)	Wire speed (m/s)	Wire in/out (↑/↓)	Remarks
20:52	-	-			-	-	-	Start the operation
21:19	-	-			-	-	-	Connect Ashura corer
21:25	363	0	74°22.5059' N	165°14.9293' W	1.3	0.0	-	PC (balance) on surface, Reset the wire length. Wire out (~0.8m/s)
21:27	358	50			1.4	0.0	-	Attach a transponder (10in.). Wire out (~1.0m/s)
21:34	358	280			1.6	0.0	-	Stop the wire out (to stabilize the PC)
21:37	358	280			1.6	-0.3	↓	Wire out
21:39:58	356	325	74°22.5055' N 74°22.5394' N	165°14.8974' W 165°14.9802' W	Min. 0.0	0.3	↓	PC hit the bottom, wire in**
21:41:24	357	300	N.D. 74°22.5389' N	N.D. 165°14.9834' W	Max. 3.5	0.3	↑	PC left the bottom**
21:48	359	50			1.5	0.0	-	Remove a transponder (10in). Wire in (~0.7m/s)
21:50	357	0	74°22.5323' N	165°15.0039' W	1.5	0.4	↑	PC (balance) on surface
21:55	-	-			-	-	-	Ashura on deck
22:22	-	-			-	-	-	PC on deck

*LST: UTC -8h

**Latitude and Longitude was used the transponder's position.

Table 5.1-8. Observation log of the PC05

Cruise Name: MR10-05_Leg2 Operator: Yusuke Sato (MWJ)
 Date (UTC): #####
 Core Number: PC05 Pilot Number: PL05
 Area: North wind ridge
 Sampling Site: St.143

Corer type: Inner type piston corer Pilot type: Ashura
 Pipe length: 10m Pilot weight: 100kg
 Main wire length: 14.0m Pilot wire length: 15.5m
 Free fall: 1.6m

Weather: Fine after cloudy Wave height: 0.8m
 Wind direction: 349.0deg. Wind speed: 3.3m/s
 Current direction: 226.9deg. Current speed: 0.2knot

Time* (UTC)	Depth (m)	Wire length (m)	Latitude	Longitude	Tension (ton)	Wire speed (m/s)	Wire in/out (↑/↓)	Remarks
21:21	-	-			-	-	-	Start the operation
21:36	-	-			-	-	-	Connect Ashura corer
21:38	202	0	73°42.5901' N	162°44.4337' W	1.0	0.0	-	PC (balance) on surface, Reset the wire length. Wire out (~0.8m/s)
21:40	202	50			0.9	0.0	-	Attach a transponder (10in.). Wire out (~1.0m/s)
21:50:09	203	178	73°42.5695' N	162°44.5633' W	Min. 0.0	0.3	↓	PC hit the bottom, wire in**
			73°42.5888' N	162°44.4245' W				
21:51:20	200	163	73°42.5715' N	162°44.5531' W	Max. 2.6	0.3	↑	PC left the bottom**
			73°42.5888' N	162°44.4247' W				
21:55	204	50			1.0	0.0	-	Remove a transponder (10in). Wire in (~0.7m/s)
21:58	204	0	73°42.5918' N	162°44.4064' W	1.0	0.4	↑	PC (balance) on surface
22:04	-	-			-	-	-	Ashura on deck
22:24	-	-			-	-	-	PC on deck

*LST: UTC -8h

**Latitude and Longitude was used the transponder's position.

Table 5.1-9. Observation log of the MCst.012

Cruise Name: MR10-05_Leg2 Operator: Yusuke Sato(MWJ)
 Date: (UTC) 2010/9/5
 Core Number: MCst12
 Area: Chukchi sea
 Sampling Site: St.12

Weather: Fog
 Wind direction: 42.0deg. Wind speed: 4.9m/s
 Current direction: 53.6deg. Current speed: 0.5knot

Time* (UTC)	Depth (m)	Wire length (m)	Latitude	Longitude	Tension (ton)	Wire speed (m/s)	Wire in/out (↑/↓)	Remarks
22:31	-	-			-	-	-	Start the operation
22:33	49	0	69°59.9864' N	167°59.9950' W	0.5	0.0	-	MC on surface, Reset the wire length Wire out (~0.3m/s)
22:33	49	0			0.5	-0.3	↓	Wire out
22:37:27	49	45	69°59.9852' N	167°59.9931' W	Min. 0.0	0.3	↓	MC hit the bottom, Wire out 5m
22:37	49	49			0.0	0.0	-	Wire stop. Wait 10 seconds
22:38	49	49			0.0	-0.3	↑	Wire in
22:38:52	49	40	69°59.9842' N	167°59.9933' W	Max. 1.2	0.3	↑	MC left the bottom**
22:42	49	0	69°59.9809' N	167°59.9942' W	0.5	0.2	↑	MC on surface
22:44	-	-			-	-	-	MC on deck

*LST: UTC -8h

**Latitude and Longitude was used the ship's position.

Table 5.1-10. Observation log of the MC01

Cruise Name: MR10-05_Leg2 Operator: Yusuke Sato(MWJ)
 Date: (UTC) 2010/9/9
 Core Number: MC01
 Area: Barrow Canyon
 Sampling Site: St.PC01

Weather: Fog
 Wind direction: 5.9deg. Wind speed: 6.4m/s
 Current direction: 64.3deg. Current speed: 0.8knot

Time* (UTC)	Depth (m)	Wire length (m)	Latitude	Longitude	Tension (ton)	Wire speed (m/s)	Wire in/out (↑/↓)	Remarks
16:06	-	-			-	-	-	Start the operation
16:20	407	0	71°57.3035' N	153°46.6925' W	0.5	0.0	-	MC on surface, Reset the wire length. Wire out (~1.0m/s)
16:16	406	380			0.8	0.0	-	Wire stop.
16:19	408	380			0.8	-0.3	↓	Wire out.
16:20:42	408	406	71°57.3043' N	153°46.6938' W	Min. 0.1	0.3	↓	MC hit the bottom, Wire out 5m
16:20	408	411			0.2	0.0	-	Wire stop. Wait 10 seconds
16:21	409	411			0.3	-0.3	↑	Wire in
16:22:32	406	402	71°57.3054' N	153°46.6932' W	Max. 1.4	0.3	↑	MC left the bottom** Wire in (~1.0m/s)
16:31	406	0	71°57.3028' N	153°46.6832' W	0.6	0.1	↑	MC on surface
16:34	-	-			-	-	-	MC on deck

*LST: UTC -8h

**Latitude and Longitude was used the ship's position.

Table 5.1-11. Observation log of the MCst.039

Cruise Name: MR10-05_Leg2 Operator: Yuki Miyajima(MWJ)
 Date: (UTC) 2010/9/18
 Core Number: MCst39
 Area: Chukchi Abyssal Plain (CAP)
 Sampling Site: St.39

Weather: Cloudy
 Wind direction: 123deg. Wind speed: 10.7m/s
 Current direction: 42.7deg. Current speed: 0.4knot

Time* (UTC)	Depth (m)	Wire length (m)	Latitude	Longitude	Tension (ton)	Wire speed (m/s)	Wire in/out (↑/↓)	Remarks
0:31	-	-			-	-	-	Start the operation
0:33	2123	0	76°00.5645' N	174°58.6815' W	0.4	0.0	-	MC on surface, Reset the wire length. Wire out (~1.0m/s)
0:43	2122	500			0.9	0.0	-	Start the swell compensator. Wire out (~1.0m/s)
0:51	2124	1000			1.3	1.0	↓	
0:59	2122	1500			1.7	1.0	↓	
1:07	2121	2000			2.1	1.0	↓	
1:09	2121	2090			2.3	0.0	-	Wire stop.
1:13	2124	2090			2.3	-0.3	↓	Wire out.
1:14:23	2121	2116	76°00.5320' N	174°58.7420' W	Min. 1.7	0.3	↓	MC hit the bottom, Wire out 5m
1:15	2120	2121			1.7	0.0	-	Wire stop. Wait 10 seconds
1:15	2120	2121			1.7	-0.3	↑	Wire in
1:16:53	2121	2109	76°00.5312' N	174°58.7370' W	Max. 3.1	0.3	↑	MC left the bottom** Wire in (~1.0m/s)
1:19	2122	2000			2.4	1.0	↑	
1:27	2121	1500			2.0	1.0	↑	
1:35	2123	1000			1.5	1.0	↑	
1:46	2123	500			0.9	0.0	-	Stop the swell compensator. Wire in (~1.0m/s)
1:55	2124	0	76°00.5827' N	174°58.6285' W	0.6	0.4	↑	MC on surface
1:57	-	-			-	-	-	MC on deck

*LST: UTC -8h

**Latitude and Longitude was used the ship's position.

Table 5.1-12. Observation log of the MCst.126

Cruise Name: MR10-05_Leg2 Operator: Yuki Miyajima(MWJ)
 Date: (UTC) 2010/10/3
 Core Number: MCst126
 Area: Northwind Abyssal Plain (NAP)
 Sampling Site: St.126

Weather: Snow
 Wind direction: 138deg. Wind speed: 6.0m/s
 Current direction: 226.9deg. Current speed: 0.4knot

Time* (UTC)	Depth (m)	Wire length (m)	Latitude	Longitude	Tension (ton)	Wire speed (m/s)	Wire in/out (↑/↓)	Remarks
16:09	-	-			-	-	-	Start the operation
16:10	1973	0	75°00.0742' N	162°00.5078' W	0.4	0.0	-	MC on surface, Reset the wire length. Wire out (~1.0m/s)
16:21	1973	500			0.9	0.0	-	Start the swell compensator. Wire out (~1.0m/s)
16:30	1974	1000			1.2	1.0	↓	
16:38	1973	1500			1.7	1.0	↓	
16:46	1973	1940			2.2	0.0	-	Wire stop.
16:49	1973	1940			2.2	-0.3	↓	Wire out.
16:51:17	1973	1968	75°00.0316' N	162°00.2932' W	Min. 1.5	0.3	↓	MC hit the bottom, Wire out 5m
16:51	1973	1972			1.7	0.0	-	Wire stop. Wait 10 seconds
16:52	1972	1973			1.7	-0.3	↑	Wire in
16:52:42	1972	1965	75°00.0310' N	162°00.2942' W	Max. 3.1	0.3	↑	MC left the bottom** Wire in (~1.0m/s)
17:01	1974	1500			1.9	1.0	↑	
17:09	1973	1000			1.5	1.0	↑	
17:18	1974	500			0.9	0.0	-	Stop the swell compensator. Wire in (~1.0m/s)
17:30	1974	0	74°59.9830' N	162°00.1005' W	0.6	0.2	↑	MC on surface
17:32	-	-			-	-	-	MC on deck

*LST: UTC -8h

**Latitude and Longitude was used the ship's position.

Table 5.1-13. Observation log of the MCst.164

Cruise Name: MR10-05_Leg2 Operator: Yuki Miyajima(MWJ)
 Date: (UTC) #####
 Core Number: MCst164
 Area: Chukchi sea
 Sampling Site: St.164

Weather: Snow
 Wind direction: 304.0deg. Wind speed: 0.2m/s
 Current direction: 342.0deg. Current speed: 0.1knot

Time* (UTC)	Depth (m)	Wire length (m)	Latitude	Longitude	Tension (ton)	Wire speed (m/s)	Wire in/out (↑/↓)	Remarks
15:58	-	-			-	-	-	Start the operation
15:59	45	0	70°59.9767' N	161°59.9098' W	0.5	0.0	-	MC on surface, Reset the wire length Wire out (~0.3m/s)
15:59	45	0			0.5	~0.3	↓	Wire out
16:02:44	45	42	70°59.9760' N	161°59.9109' W	Min. 0.0	0.3	↓	MC hit the bottom, Wire out 5m
16:03	45	47			0.0	0.0	-	Wire stop. Wait 10 seconds
16:03	45	47			0.0	~0.3	↑	Wire in
16:04:08	45	38	70°59.9751' N	161°59.9145' W	Max. 1.3	0.3	↑	MC left the bottom**
16:07	45	0	70°59.9743' N	161°59.9177' W	0.5	0.2	↑	MC on surface
16:09	-	-			-	-	-	MC on deck

*LST: UTC -8h

**Latitude and Longitude was used the ship's position.

Table 5.1-14. Observation log of the MCst.165

Cruise Name: MR10-05_Leg2 Operator: Yusuke Sato(MWJ)
 Date: (UTC) #####
 Core Number: MCst165
 Area: Chukchi sea
 Sampling Site: St.165

Weather: Cloudy
 Wind direction: 91deg. Wind speed: 6.1m/s
 Current direction: 187.2deg. Current speed: 0.1knot

Time* (UTC)	Depth (m)	Wire length (m)	Latitude	Longitude	Tension (ton)	Wire speed (m/s)	Wire in/out (↑/↓)	Remarks
20:35	-	-			-	-	-	Start the operation
20:37	44	0	70°29.8031' N	164°45.7413' W	0.4	0.0	-	MC on surface, Reset the wire length Wire out (~0.3m/s)
20:37	44	0			0.4	~0.3	↓	Wire out
20:40:05	44	42	70°29.7977' N	164°45.7460' W	Min. 0.0	0.3	↓	MC hit the bottom, Wire out 5m
20:43	44	47			0.0	0.0	-	Wire stop. Wait 20 seconds
20:43	44	47			0.0	~0.3	↑	Wire in
20:41:25	44	39	70°29.7970' N	164°45.7439' W	Max. 1.4	0.3	↑	MC left the bottom**
20:44	44	0	70°29.8013' N	164°45.7480' W	0.5	0.6	↑	MC on surface
20:46	-	-			-	-	-	MC on deck

*LST: UTC -8h

**Latitude and Longitude was used the ship's position.

Table 5.1-15. Observation log of the MCst.169

Cruise Name: MR10-05_Leg2 Operator: Yasushi Hashimoto(MWJ)
 Date: (UTC) #####
 Core Number: MCst169
 Area: Chukchi sea
 Sampling Site: St.169

Weather: Cloudy
 Wind direction: 90deg. Wind speed: 3.4m/s
 Current direction: 245.0deg. Current speed: 0.2knot

Time* (UTC)	Depth (m)	Wire length (m)	Latitude	Longitude	Tension (ton)	Wire speed (m/s)	Wire in/out (↑/↓)	Remarks
17:11	-	-			-	-	-	Start the operation
17:14	53	0	68°29.9690' N	168°49.9153' W	0.4	0.0	-	MC on surface, Reset the wire length Wire out (~0.3m/s)
17:14	53	0			0.5	~0.3	↓	Wire out
17:17:07	53	50	68°29.9690' N	168°49.9173' W	Min. 0.0	0.3	↓	MC hit the bottom, Wire out 5m
17:17	53	55			0.0	0.0	-	Wire stop. Wait 20 seconds
17:17	53	55			0.0	~0.3	↑	Wire in
17:18:24	53	47	68°29.9749' N	168°49.9162' W	Max. 1.1	0.3	↑	MC left the bottom**
17:21	53	0	68°29.9661' N	168°49.9130' W	0.5	0.3	↑	MC on surface
17:23	-	-			-	-	-	MC on deck

*LST: UTC -8h

**Latitude and Longitude was used the ship's position.

Table 5.1-16. Observation log of the MCst.172

Cruise Name: MR10-05_Leg2 Operator: Yuki Miyajima(MWJ)
 Date: (UTC) #####
 Core Number: MCst172
 Area: Chukchi sea
 Sampling Site: St.172

Weather: Cloudy
 Wind direction: 170deg. Wind speed: 13.0m/s
 Current direction: 22.7deg. Current speed: 0.7knot

Time* (UTC)	Depth (m)	Wire length (m)	Latitude	Longitude	Tension (ton)	Wire speed (m/s)	Wire in/out (↑/↓)	Remarks
2:07	-	-			-	-	-	Start the operation
2:14	46	0	67°00.0031' N	168°49.9312' W	0.4	0.0	-	MC on surface, Reset the wire length Wire out (~0.3m/s)
2:14	46	0			0.4	~0.3	↓	Wire out
2:17:20	46	43	67°00.0025' N	168°49.9351' W	Min. 0.0	0.3	↓	MC hit the bottom, Wire out 5m
2:17	46	48			0.0	0.0	-	Wire stop. Wait 10 seconds
2:17	46	48			0.0	~0.3	↑	Wire in
2:18:28	46	41	67°00.0025' N	168°49.9397' W	Max. 1.3	0.3	↑	MC left the bottom**
2:21	46	0	67°00.0032' N	168°49.9525' W	0.6	0.3	↑	MC on surface
2:23	-	-			-	-	-	MC on deck

*LST: UTC -8h

**Latitude and Longitude was used the ship's position.

5.2. Sea bottom topography measurement

(1) Personnel

Takeshi Matsumoto University of the Ryukyus: Principal Investigator (Not on-board)		
Kazuho Yoshida	Global Ocean Development Inc.: GODI	- Leg1 -
Norio Nagahama	GODI	- Leg2 -
Satoshi Okumura	GODI	- Leg2 -
Souichiro Sueyoshi	GODI	- Leg2 -
Asuka Doi	GODI	- Leg2 -
Wataru Tokunaga	MIRAI Crew	

(2) Objective

R/V MIRAI equipped a Multi Beam Echo Sounding system (MBES), SEABEAM 2112.004 (SeaBeam Instruments Inc.).

The main objective of MBES survey is collecting continuous bathymetry data along ship's track to make a contribution to geological and geophysical investigations and global datasets. We had carried out bathymetric survey throughout the MR10-05 cruise.

(3) Instruments and Methods

MBES was used for bathymetry mapping during this cruise. To get accurate sound velocity of water column for ray-path correction of acoustic multibeam, we used Surface Sound Velocimeter (SSV) data for the surface (6.2m) sound velocity, and below that the sound velocity profile calculated from temperature and salinity data obtain CTD or XCTD based on the equation in Del Grosso (1974).

System configuration and performance of SEABEAM 2112.004

Frequency:	12 kHz
Transmit beam width:	2 degree
Transmit power:	20 kW
Transmit pulse length:	3 to 20 msec.
Depth range:	100 to 11,000 m
Beam spacing:	1 degree athwart ship
Swath width:	150 degree (max) 120 degree to 4,500 m 100 degree to 6,000 m 90 degree to 11,000 m
Depth accuracy:	Within < 0.5% of depth or +/-1m, whichever is greater, over the entire swath.

(Nadir beam has greater accuracy; typically within < 0.2% of depth or +/-1m, whichever is greater)

(4) Data Archives

Bathymetry data obtained during this cruise will be submitted to the Data Integration and Analysis Group (DIAG) of JAMSTEC.

(5) Remarks

i) Following periods, we operated in manual setting of surface sound velocity.

19:46UTC 27 Aug. 2010 - 20:15UTC 27 Aug. 2010

19:51UTC 28 Aug. 2010 - 02:56UTC 29 Aug. 2010

12:58UTC 29 Aug. 2010 - 15:50UTC 29 Aug. 2010

00:00UTC 13 Sep. 2010 - 04:03UTC 21 Aug. 2010

23:02UTC 21 Aug. 2010 - 23:45UTC 21 Aug. 2010

ii) Following periods, we input the calculated value from EPCS(SST and SSS) as the surface sound velocity.

06:54UTC - 07:14UTC 12 Oct. 2010

5.3. Sea surface gravity measurement

(1) Personnel

Takeshi Matsumoto University of the Ryukyus: Principal Investigator (Not on-board)		
Kazuho Yoshida	Global Ocean Development Inc.: GODI	- Leg1 -
Norio Nagahama	GODI	- Leg2 -
Satoshi Okumura	GODI	- Leg2 -
Souichiro Sueyoshi	GODI	- Leg2 -
Asuka Doi	GODI	- Leg2 -
Wataru Tokunaga	MIRAI Crew	

(2) Objective

The distribution of local gravity is an important parameter in geophysics and geodesy. We collected gravity data at the sea surface throughout the MR10-05 cruise from Sekinehama on 24 August 2010 to Dutch Harbor on 16 October 2010.

(3) Parameters

Relative Gravity [CU: Counter Unit]
 $[mGal] = (\text{coefl: } 0.9946) * [CU]$

(4) Instruments and Methods

We measured relative gravity using LaCoste and Romberg air-sea gravity meter S-116 (Micro-g LaCoste, LLC) during this cruise. To convert the relative gravity to absolute one, we measured gravity using portable gravity meter (Scintrex gravity meter CG-3M), at Sekinehama Port as reference point.

(5) Preliminary Results

Absolute gravity table is shown in Table 5.3-1

Table 5.3-1 Absolute gravity table

Date	UTC	Port	Absolute Gravity [mGal]	Sea Level [cm]	Draft [cm]	Gravity at Sensor *1 [mGal]	L&R*2 Gravity [mGal]	
No.1	8/18	03:20	Sekinehama	980371.95	248	644	980372.77	12660.81

*1: Gravity at Sensor= Absolute Gravity + Sea Level*0.3086 /100 + (Draft-530) / 100*0.0431

*2: LaCoste and Romberg air-sea gravity meter S-116

(6) Data Archives

Gravity data obtained during this cruise will be submitted to the Data Integration and Analysis Group (DIAG) of JAMSTEC.

(7) Remarks

- i) Following period, GRV data acquisition was stopped due to network trouble.
The departure of Sekinehama - 12:19UTC 24 Aug. 2010
- ii) The following period, data was not available.
06:54UTC - 07:14UTC 12 Oct. 2010

5.4. Surface three component magnetic field measurements

(1) Personnel

Takeshi Matsumoto University of the Ryukyus: Principal Investigator (Not on-board)		
Kazuho Yoshida	Global Ocean Development Inc.: GODI	- Leg1 -
Norio Nagahama	GODI	- Leg2 -
Satoshi Okumura	GODI	- Leg2 -
Souichiro Sueyoshi	GODI	- Leg2 -
Asuka Doi	GODI	- Leg2 -
Wataru Tokunaga	MIRAI Crew	

(2) Objective

Measurement of magnetic force on the sea is required for the geophysical investigations of marine magnetic anomaly caused by magnetization in upper crustal structure. We measured geomagnetic field using a three-component magnetometer during the MR10-05 cruise from Sekinehama on 24 August 2010 to Datch Harbor on 16 October 2010.

(3) Instruments and Methods

A shipboard three-component magnetometer system (Tierra Tecnica SFG1214) is equipped on-board R/V MIRAI. Three-axes flux-gate sensors with ring-cored coils are fixed on the fore mast. Outputs from the sensors are digitized by a 20-bit A/D converter (1 nT/LSB), and sampled at 8 times per second. Ship's heading, pitch, and roll are measured by the Inertial Navigation System (INS) for controlling attitude of a Doppler radar. Ship's position (GPS) and speed data are taken from LAN every second.

The relation between a magnetic-field vector observed on-board, \mathbf{H}_{ob} , (in the ship's fixed coordinate system) and the geomagnetic field vector, \mathbf{F} , (in the Earth's fixed coordinate system) is expressed as:

$$\mathbf{H}_{ob} = \mathbf{A} \mathbf{R} \mathbf{P} \mathbf{Y} \mathbf{F} + \mathbf{H}_p \quad (a)$$

where \mathbf{R} , \mathbf{P} and \mathbf{Y} are the matrices of rotation due to roll, pitch and heading of a ship, respectively. $\tilde{\mathbf{A}}$ is a 3 x 3 matrix which represents magnetic susceptibility of the ship, and \mathbf{H}_p is a magnetic field vector produced by a permanent magnetic moment of the ship's body. Rearrangement of Eq. (a) makes

$$\mathbf{B} \mathbf{H}_{ob} + \mathbf{H}_{bp} = \mathbf{R} \mathbf{P} \mathbf{Y} \mathbf{F} \quad (b)$$

where $\mathbf{B} = \mathbf{A}^{-1}$, and $\mathbf{H}_{bp} = -\mathbf{B} \mathbf{H}_p$. The magnetic field, \mathbf{F} , can be obtained by measuring \mathbf{R} , \mathbf{P} , \mathbf{Y} and \mathbf{H}_{ob} , if \mathbf{B} and \mathbf{H}_{bp} are known. Twelve constants in \mathbf{B} and \mathbf{H}_{bp} can be determined by measuring variation of \mathbf{H}_{ob} with \mathbf{R} , \mathbf{P} and \mathbf{Y} at a place where

the geomagnetic field, \mathbf{F} , is known.

(4) Data Archives

These data obtained in this cruise will be submitted to the Data Integration and Analysis Group (DIAG) of JAMSTEC.

(5) Remarks

- i) For calibration of the ship's magnetic effect, we made a "figure-eight" turn (a pair of clockwise and anti-clockwise rotation). This calibration was carried out as below.

06 Sep. 2010, 00:56 to 01:21 UTC

11 Sep. 2010, 13:33 to 13:58 UTC

16 Sep. 2010, 00:27 to 00:52 UTC

- ii) From 25 Aug. 2010, speed, gyro, longitude, latitude and depth sometimes were not updated about some 10 seconds due to the network trouble.

- iii) The following period, data was not available.

06:54UTC 12 Oct. 2010 - 07:15UTC 12 Oct. 2010

Appendix I. CTD and XCTD stations.

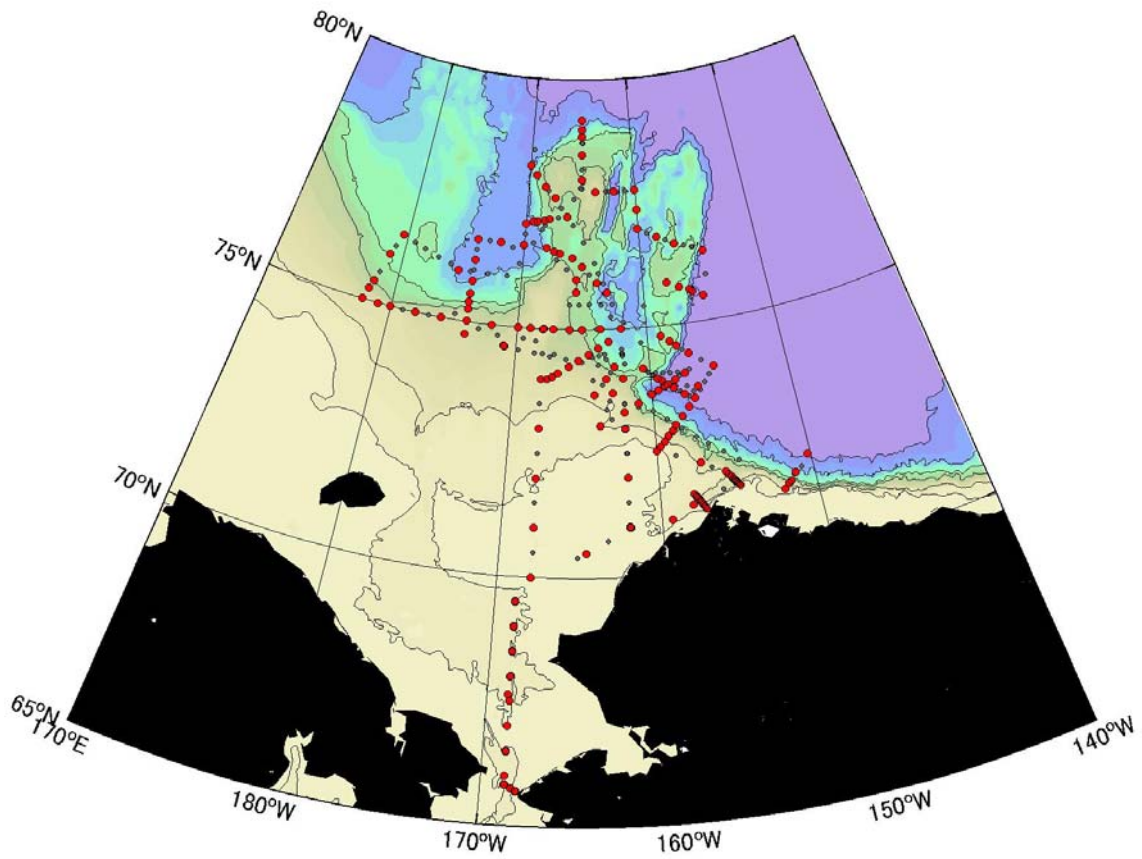

Red and gray dots indicate the CTD and XCTD station, respectively.

Appendix II. Sea ice and sea surface temperature distribution during the cruise

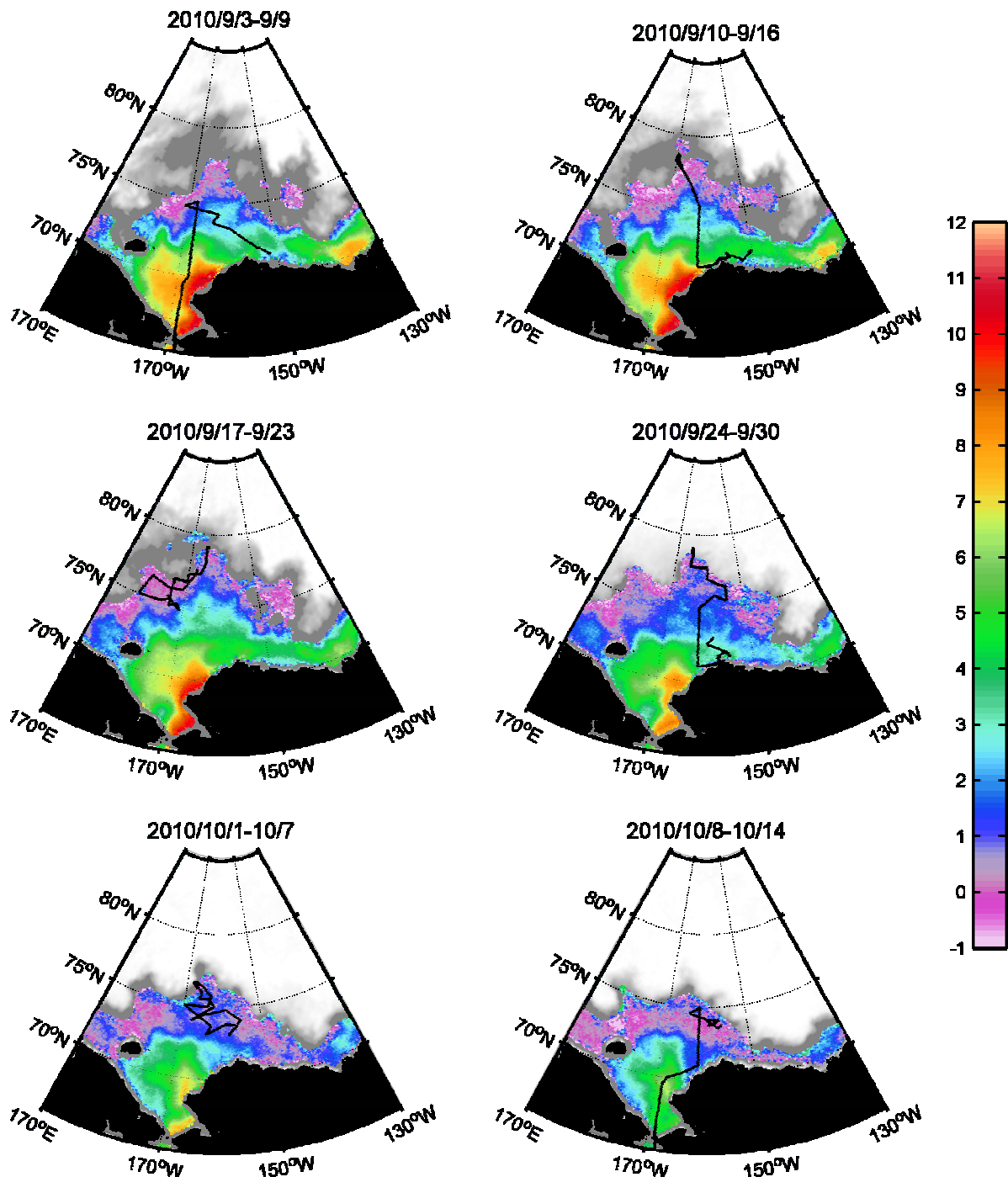

Time series of sea-ice concentration and sea surface temperature, deduced from Advanced Microwave Scanning Radiometer for Earth Observing System (AMSRE) data. The cruise tracks are superimposed.

AppendixIII. Bottle Data Inventory

Sta	JAMSTEC-Main mission										IARC	JAM-Paleo			Hokkaido Univ.				Tsukuba Univ.					JAM	JAM	HU	HU	JAM	JAM-P	HU	HU	HU	HU	JAM-P	HU	NIES	NIES											
	Sal	DO	Nuts	TA	DIC	H2 18O	Total	Size	CN	Dens	Fe	CoDia	Diatom	HPLC	Abs	P-inc	Phyto	DI14C	DO14C	Bac1	Bac2	Bac-inc	POC	LADCP	TM	PRR	HS	NADCP	NNJ	NN	RNN	RNND	Ice	MC	MC	MC	PC											
001.1	x	x	x	x	x	x	x			x		x	x	x	x	x								x		x																						
002.1	x	x	x	x	x	x																		x																								
003.1	x	x	x	x	x	x																		x																								
004.1	x	x	x											x	x		x							x		x	x				x																	
005.1																								x																								
006.1	x	x	x	x	x	x	x						x				x													x	x																	
007.1	x	x	x				x												x	x					x																							
008.1	x	x	x	x	x	x	x			x							x								x						x																	
009.1																									x																							
010.1	x	x	x	x	x	x	x						x				x							x							x																	
011.1																								x																								
012.1	x	x	x	x	x	x	x			x			x	x	x	x	x			x	x	x	x		x		x	x	x	x									x									
013.1	x	x	x	x	x	x	x																		x																							
014.1	x	x	x	x	x	x	x			x															x																							
015.1	x	x	x	x	x	x	x						x												x																							
016.1	x	x	x	x	x	x	x			x															x																							
017.1	x	x	x	x	x	x	x					x					x								x						x	x																
018.1																		x						x		x																						
018.2	x	x	x	x	x	x	x	x	x				x	x	x	x	x								x		x	x	x	x										x								
019.1	x	x	x	x	x	x	x	x	x	x															x		x													x								
020.1	x	x	x	x	x	x	x	x																	x	x																						
021.1	x	x	x	x	x	x	x	x						x	x										x			x	x											x								
022.1	x	x	x	x	x	x	x	x		x										x	x	x	x			x	x														x							
023.1	x	x	x	x	x	x	x	x																	x			x	x	x	x	x																
024.1	x	x	x	x	x	x	x	x				x													x	x																						
025.1	x	x	x																						x																							
026.1	x	x	x	x	x	x	x	x																	x	x																						
027.1																																																
028.1	x	x	x	x	x	x	x	x	x		x	x	x	x	x	x	x			x	x				x	x	x	x	x	x											x							
029.1																									x		x																					
030.1																																																
031.1	x	x	x																																													
032.1	x	x	x	x	x	x																																										
033.1	x	x	x																																													
034.1	x	x	x	x	x	x	x	x																																								
035.1	x	x	x	x	x	x	x	x																																								
036.1	x	x	x	x	x	x																																										
037.1	x	x	x																																													
038.1	x	x	x	x	x	x	x	x																																								
039.1	x	x	x	x	x	x	x	x		x																																						
040.1	x	x	x	x	x	x	x	x																																								
041.1	x	x	x	x	x	x																																										
042.1	x	x	x	x	x	x	x	x																																								
043.1	x	x	x	x	x	x																																										
044.1	x	x	x	x	x	x	x	x																																								
045.1																																																
046.1	x	x	x																																													
047.1	x	x	x	x	x	x																																										
048.1	x	x	x	x	x																																											
049.1	x	x	x	x	x	x	x	x	x		x																																					
050.1	x	x	x																																													

Sta	JAMSTEC-Main mission										IARC		JAM-Paleo			Hokkaido Univ.					Tsukuba Univ.					JAM	JAM	HU	HU	JAM	JAM-P	HU	HU	HU	HU	JAM-P	HU	NIES	NIES
	Sal	DO	Nuts	TA	DIC	H2 18O	Total	Size	CN	Dens	Fe	CoDia	Diatom	HPLC	Abs	P-inc	Phyto	DI14C	DO14C	Bac1	Bac2	Bac-inc	POC	LADGP	TM	PRR	HS	NADGP	NNJ	NN	RNN	RNND	Ice	MC	MC	MC	PC		
051.1	x	x	x	x	x	x	x	x					x	x		x							x																
052.1	x	x	x																					x															
053.1	x	x	x	x	x	x										x								x						x									
054.1	x	x	x	x	x	x																		x															
055.1																		x		x			x																
056.1	x	x	x	x	x	x	x	x	x		x			x	x		x		x	x				x	x	x	x												
057.1																								x															
058.1	x	x	x	x	x	x				x		x	x			x								x				x	x	x									
059.1																								x															
060.1	x	x	x																					x	x														
061.1																								x															
062.1	x	x	x	x	x	x								x	x		x		x					x			x												
063.1	x	x	x	x	x																			x															
064.1																								x	x														
065.1	x	x	x	x	x	x	x	x												x	x								x	x	x								
066.1																								x															
067.1																								x															
068.1	x	x	x	x	x	x	x	x	x		x	x				x		x	x	x				x															
069.1																		x		x				x															
070.1	x	x	x	x	x		x	x			x			x	x	x	x							x				x	x	x	x								
071.1	x	x	x	x	x	x	x	x						x	x									x															
072.1	x	x	x	x	x	x	x			x				x	x	x								x			x	x	x	x									
073.1																								x															
074.1																								x															
075.1	x	x	x	x	x	x											x							x															
076.1																								x															
077.1	x	x	x	x	x	x	x							x	x	x				x	x						x	x	x	x									
078.1	x	x	x				x																	x															
079.1	x	x	x	x	x	x				x							x							x															
080.1																								x															
081.1	x	x	x	x	x	x	x	x	x	x	x													x	x	x	x												
082.1	x	x	x																					x	x														
083.1	x	x	x				x																	x															
084.1																								x															
085.1																								x															
086.1	x	x	x				x										x							x				x	x	x									
087.1	x	x	x				x									x								x			x	x											
088.1	x	x	x				x																	x															
089.1																								x															
090.1																								x															
091.1																								x															
092.1	x	x	x				x										x							x															
093.1																								x															
094.1																								x															
095.1																								x															
096.1	x	x	x				x																	x															
097.1																								x															
098.1																								x															
099.1																								x															
100.1																								x															

Sta	JAMSTEC-Main mission										IARC		JAM-Paleo			Hokkaido Univ.					Tsukuba Univ.					JAM	JAM	HU	HU	JAM	JAM-P	HU	HU	HU	HU	JAM-P	HU	NIES	NIES		
	Sal	DO	Nuts	TA	DIC	H2 18O	Total	Size	CN	Dens	Fe	CoDia	Diatom	HPLC	Abs	P-inc	Phyto	DI14C	DO14C	Bac1	Bac2	Bac-inc	POC	LADCP	TM	PRR	HS	NADCP	NNJ	NN	RNN	RNND	Ice	MC	MC	MC	PC				
151.1	x	x	x				x								x									x	x																
152.1																									x																
153.1	x	x	x				x																	x	x																
154.1	x	x	x							x	x		x	x		x			x	x	x			x	x	x	x			x											
155.1	x	x	x	x	x	x	x				x													x	x																
156.1	x	x	x				x																	x	x																
157.1	x	x	x				x																	x	x																
158.1	x	x	x				x					x	x	x	x		x							x			x	x			x										
159.1	x	x	x				x									x								x																	
160.1	x	x	x				x												x	x			x																		
161.1	x	x	x										x											x																	
162.1	x	x	x									x												x																	
163.1	x	x	x				x																	x																	
164.1	x	x	x												x	x								x															x		
165.1	x	x	x	x	x		x	x	x	x		x		x	x	x	x	x						x			x	x	x		x								x		
166.1	x	x	x									x		x	x		x			x	x	x		x	x	x	x			x											
167.1																								x																	
168.1	x	x	x																					x																	
169.1																	Bucket							x																x	
170.1	x	x	x				x						x	x	x	x								x			x	x													
171.1													Bucket	Bucket										x			x														
172.1	x	x	x																	x	x	x		x			x	x											x		
173.1																								x																	
174.1	x	x	x																					x																	
175.1	x	x	x				x						x	x		x								x			x	x			x									x	
176.1																								x																	
177.1																								x																	

Sampled items

Sal: Salinity
DO: Dissolved oxygen
Nuts: Nutrients
TA: Total alkalinity
DIC: Dissolved inorganic carbon
H2 18O: O-18 Oxygen isotope
Total: Total Chl-a
Size: Size fractionated Chl-a
CN: Carbon and nitrogen uptake rate
Dens: Density
Fe: Iron
CoDia: Coccolith and Diatom (Tsukuba Univ.)
Diatom: Diatom (JAMSTEC)
HPLC: High-performance liquid chromatography
Abs: Absorption
P-inc: Plankton incubation
Phyto: Phytoplankton
DI14C: Dissolved inorganic carbon-14
DO14C: Dissolved organic carbon-14
Bac1: Bacteria for FISH analysis
Bac2: Bacteria for DNA extraction
Bac-inc: Bacteria incubation
POC: Particulate organic carbon

Missions with CTD

LADCP: Lowered ADCP
TM: Turbulence profiler
PRR: Spectroradiometer
HS: HydroScat
NADCP: NORPAC net and ADCP
NNJ: NORPAC net (JAMSTEC)
NN: NORPAC net (Hokkaido Univ.)
RNN: 80cm ring net and NORPAC net for shallow water
RNND: 80cm ring net and NORPAC net for deep water
Ice: Sea ice sampling (Not conducted)
MC: Multiple core with CTD
PC: Piston core with CTD

Science parties

JAM: JAMSTEC-Main mission
JAM-P: JAMSTEC-Paleo
HU: Hokkaido Univ.
NIES: National Institute for Environmental Studies