



# radiometrics

## Profiler Operator's Manual

- **MP-3000A**
- **MP-2500A**
- **MP-1500A**



### **Radiometrics Corporation**

4909 Nautilus Court North, Suite 110

Boulder, CO 80301 USA

1+303 449-9192 (tel)

1+303 786-9343 (fax)

<http://radiometrics.com>

**Revision G**  
**Windows 7 OS**

## Release Notes Concerning this Manual

- Revision G is applicable TO “A” series profilers delivered before May 2013 that are configured with Control Computers running the Windows 7 (“Win7”) operating system.
  - The Win7 configuration requires mp.exe 6.12 or later, and VizMet-B version 3.0 or later.
  - Revision F of the Operator’s Manual is the most current manual for “A” series profilers with Control Computers running Windows XP.
- Questions regarding this Operator’s Manual should be addressed to Radiometrics Corporation Customer Service, [support@radiometrics.com](mailto:support@radiometrics.com) or 303-449-9192.

## CAUTION

**Unauthorized disassembly of the radiometer, its components or subassemblies will void all warranties.**

**The radiometer cabinet cover is closely fit to seal against intrusion of insects, spiders, wind-blown dust, sand, water and ice. Use caution if it is necessary to remove the cabinet cover. After unbuckling the latches on both sides of the cabinet, lift the cover evenly and gently, by using the handles on the cabinet cover. Forcing the cover unevenly can result in damage to the radiometer and voiding of the Warranty.**

**Substituting another computer for the Control Computer supplied by Radiometrics, or changing the factory software load and settings, may void our software and control computer Warranty support obligation. Should such changes require RDX remote support, Radiometrics will invoice these services to you at our normal hourly support rates.**

## *Table of Contents*

|          |  |           |
|----------|--|-----------|
| <b>1</b> | <b><i>General Description</i></b> .....                          | <b>1</b>  |
| 1.1      | Introduction .....   | 1         |
| 1.2      | Instrument Specification .....                                   | 5         |
| 1.3      | Profile Retrievals from Observations .....                       | 6         |
| 1.4      | Radiometer Error Sources .....                                   | 7         |
| <b>2</b> | <b><i>Profiler Hardware Description</i></b> .....                | <b>8</b>  |
| 2.1      | System Architecture .....  | 8         |
| 2.2      | Functional Description of Components .....                       | 9         |
| 2.3      | Detailed Description of Microwave Receivers .....                | 11        |
| <b>3</b> | <b><i>Installation</i></b> .....                                 | <b>12</b> |
| 3.1      | Site Selection .....   | 13        |
| 3.2      | Site Preparation .....   | 14        |
| 3.3      | Assembly and Setup .....   | 14        |
| 3.4      | Leveling the Tripod .....  | 15        |
| 3.5      | Securing the Tripod .....  | 17        |
| 3.6      | Mounting the Profiling Radiometer .....                          | 17        |
| 3.7      | Attaching the Power Cable .....                                  | 18        |
| 3.8      | Attaching the Data Cable .....                                   | 19        |
| 3.9      | Securing the Cables .....  | 19        |
| 3.10     | Installing the Control Computer .....                            | 20        |
| <b>4</b> | <b><i>Initial Operation and Test of the Instrument</i></b> ..... | <b>21</b> |
| <b>5</b> | <b><i>Configuration, Control, and Data Processing</i></b> .....  | <b>29</b> |
| 5.1      | Modes of Operation .....   | 29        |
| 5.1.1    | Operating in Manual Mode .....                                   | 29        |
| 5.1.2    | Operating in Scheduled Mode .....                                | 30        |
| 5.2      | Input Files .....  | 33        |
| 5.2.1    | Configuration File .....   | 33        |
| 5.2.2    | Procedure Files .....  | 37        |
| 5.2.3    | Factory Procedure Files .....                                    | 45        |
| 5.2.4    | Neural Network Files .....                                       | 46        |
| 5.3      | Output Files .....   | 47        |
| 5.3.1    | Output File Name Conventions .....                               | 47        |
| 5.3.2    | Record Number .....  | 48        |
| 5.3.3    | Date/Time Conventions .....                                      | 48        |
| 5.3.4    | Record Type Conventions .....                                    | 48        |
| 5.3.5    | Level0 File .....  | 48        |
| 5.3.6    | Level1 File .....  | 50        |
| 5.3.7    | Level2 File .....  | 50        |
| 5.3.8    | TIP Calibration File .....                                       | 50        |
| 5.3.9    | LN2 Calibration File .....                                       | 51        |
| 5.4      | Time Synchronization .....                                       | 51        |

|          |  |           |
|----------|--|-----------|
| 5.5      | Reprocessing .....   | 51        |
| <b>6</b> | <b><i>Maintenance and Trouble Shooting</i></b> .....           | <b>52</b> |
| 6.1      | Instrument Maintenance.....                                    | 52        |
| 6.1.1    | Radiometer Calibration .....                                   | 52        |
| 6.1.2    | Antenna Pointing Calibration.....                              | 52        |
| 6.1.3    | Cleaning the Hydrophobic Radome Surface .....                  | 53        |
| 6.1.4    | Radome Replacement .....                                       | 53        |
| 6.1.5    | Relative Humidity (RH) and Temperature Sensor Maintenance..... | 55        |
| 6.1.6    | Superblower Filter Cleaning and Replacement.....               | 57        |
| 6.1.7    | Rain Sense PCBA.....   | 58        |
| 6.1.8    | IRT Window Maintenance .....                                   | 59        |
| 6.1.9    | Cables .....   | 59        |
| 6.2      | Control Computer.....  | 59        |
| 6.2.1    | Operating System Updates .....                                 | 59        |
| 6.2.2    | Operating Code Updates .....                                   | 60        |
| 6.2.3    | Neural Network and Procedure File Updates.....                 | 60        |
| 6.2.4    | Firmware Updates.....  | 60        |
| 6.2.5    | Virus Protection and Firewall.....                             | 60        |
| 6.2.6    | Error Messages.....  | 60        |
| <b>7</b> | <b><i>Warranty and Service</i></b> .....                       | <b>61</b> |
| 7.1      | European Certification.....                                    | 62        |
| 7.2      | Symbols Legend .....   | 62        |

## *List of Appendices*

- Appendix A: TP-2000 Tripod Assembly
- Appendix B: Theory of Operation
- Appendix C: Error Messages for A Series Radiometers, Version 6.xx Operating Code
- Appendix D: VizMet-B User's Guide
- Appendix E: LN2 Calibration
- Appendix F: Cable Data
- Appendix G: Removal and Replacement of Common FRUs
- Appendix H: Azimuth Positioner Installation and Removal
- Appendix I: VizMet-B Re-Install Instructions
- Appendix J: Off-Zenith Procedures
- Appendix K: Weights and Dimensions

## *List of Figures*

|   |      |
|---|------|
| Figure F-1-1. VizMet-B display .....  | viii |
| Figure 1-1. MP-3000A with optional Azimuth Positioner and IRT .....                     | 1    |
| Figure 1-2. MP-3000A cut-away diagram .....   | 4    |
| Figure 2-1. MP-3000A block diagram .....  | 8    |
| Figure 2-2. MP-3000A Radiometer, internal view .....                                    | 10   |
| Figure 2-3. Optional IRT Assembly (left) and optional Azimuth Positioner (right) .....  | 11   |
| Figure 3-1. Tripod and anchor chain with profiling radiometer .....                     | 15   |
| Figure 3-2. Leveling the TP-2000 Tripod .....   | 16   |
| Figure 3-3. Leveling directions .....   | 16   |
| Figure 3-4. Securing the profiling radiometer with the T-Bolt .....                     | 17   |
| Figure 3-5. Power cable supplied by Radiometrics .....                                  | 18   |
| Figure 3-6. Front Connector Panel .....   | 18   |
| Figure 3-7. Data cable .....  | 19   |
| Figure 3-8. Cable service loop for use with Azimuth Positioner .....                    | 20   |
| Figure 4-1. Operating Code display after power-on tests have completed .....            | 22   |
| Figure 4-2. Main menu screen .....  | 23   |
| Figure 4-3. Key 1 for level1 data (brightness temperature) .....                        | 25   |
| Figure 4-4. Key 2 for level2 data (profiles and integrated values) .....                | 26   |
| Figure 4-5. Key T for TIP calibration display: K band noise diode calibrations .....    | 27   |
| Figure 4-6. Example of level1 brightness temperature time series plotted in Excel ..... | 28   |
| Figure 5-1. Task Scheduler window .....   | 31   |
| Figure 5-2. List of Scheduled Tasks .....   | 32   |
| Figure 5-3. Configuration file (mp.cfg) for v6.x.x operating code .....                 | 35   |
| Figure 5-4. Theoretical thermal noise for radiometers .....                             | 45   |
| Figure 6-1. Radome replacement .....  | 54   |
| Figure 6-2. Radome Retainer with external screws and washers .....                      | 55   |
| Figure 6-3. Superblower End Cover removal .....   | 56   |
| Figure 6-4. Sensor screen removal and cleaning .....                                    | 56   |
| Figure 6-5. Sensor removal .....  | 57   |
| Figure 6-6. Sensor removal, later models .....  | 57   |
| Figure 6-7. Superblower filter removal and cleaning .....                               | 58   |
| Figure 6-8. Close-up view of Rain Sense PCBA; connector on underside (right) .....      | 58   |
| Figure 6-9. GPS Receiver on the left; IRT window on the right .....                     | 59   |

*List of Tables*

|   |    |
|---|----|
| Table 1-1. Instrument specifications.....                             | 6  |
| Table 2-1. Antenna performance.....                                   | 10 |
| Table 4-1. Main menu options.....                                     | 23 |
| Table 5-1. Bat files .....  | 30 |
| Table 5-2. Tabbed properties of scheduled tasks .....                 | 33 |
| Table 5-3. Antenna coordinate system.....                             | 38 |
| Table 5-4. Housekeeping data parameters logged by “eng command” ..... | 41 |
| Table 5-5. Standard procedure files .....                             | 46 |
| Table 5-6. Level0 record types.....                                   | 49 |
| Table 5-7. Level1 record types.....                                   | 50 |
| Table 5-8. Level2 record types.....                                   | 50 |
| Table 5-9. TIP calibration record types.....                          | 51 |
| Table 5-10. LN2 calibration record types.....                         | 51 |

## Optional VizMet-B Software Package

All profiling radiometers are now available with Radiometrics' VizMet-B software package. VizMet-B turns the instrument Control Computer into a powerful web server, providing interactive access to the instrument from any remote computer connected by LAN or the Internet.<sup>1</sup> With the optional VizMet-B software installed on the Control Computer, authorized users can log in and configure, control, calibrate and monitor all aspects of the instrument operation, from anywhere, without installing any special software on the remote computer. The VizMet-B color GUI simplifies and automates the configuration, control, and calibration of the instrument. The 2D and 3D color graphics provide a running 72-hour "quick look history" of the level1 and level2 data products. For further information on VizMet-B, refer to **Appendix D**.

- If the optional VizMet-B software package (described below) has been installed, refer to this Operator's Manual for general information about the profiling radiometer, and the separate document, VizMet-B User Guide, for specific information about the operation of the profiling radiometer using VizMet-B.
- If the VizMet-B software package has not been installed, use the single-user Graphical User Interface (GUI) described in this Operator's Manual to configure, control, calibrate and monitor the operation of the profiling radiometer.

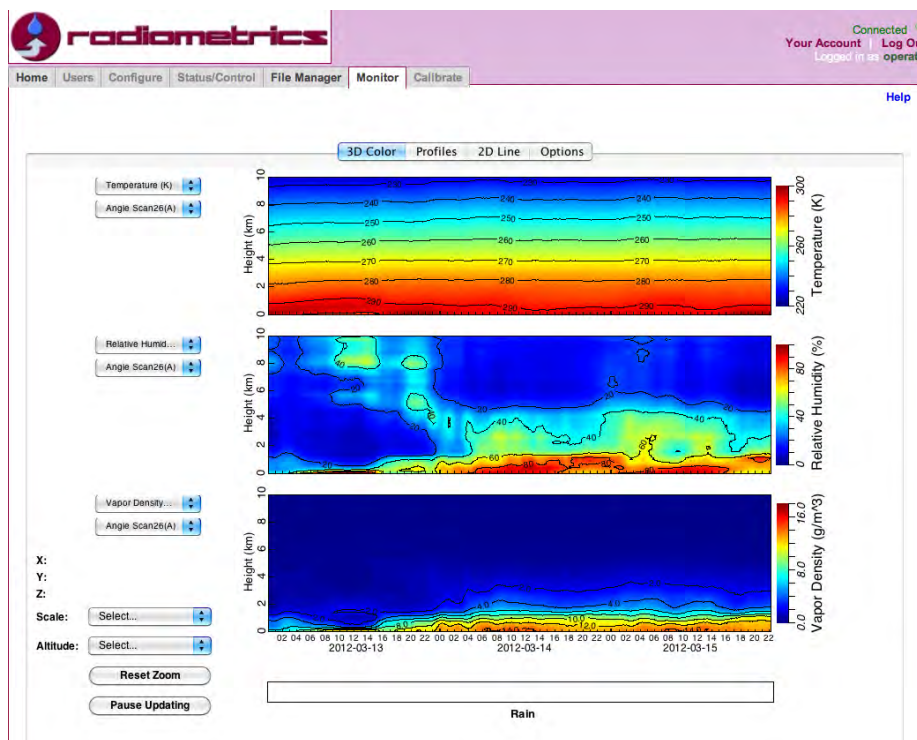

Figure F-1-1. VizMet-B display

<sup>1</sup> The VizMet-B software package uses Java technology to enable any modern Windows, Mac, Unix, or Linux computer to connect and display the GUI. Remote computers only require a browser (IE or Firefox) and Java.



# 1 General Description

## 1.1 Introduction

This manual provides information about the operation of Radiometrics' family of advanced portable profiling microwave radiometers.



**Figure 1-1. MP-3000A with optional Azimuth Positioner and IRT**

Information on the following models is included:

### **MP-3000A Portable Profiling Microwave Radiometer**

- 21 K band (22-30 GHz) plus 14 V band (51-59 GHz) factory-calibrated channels
- Measures brightness temperatures in both water vapor and oxygen bands
- Measures cloud base temperature and height with optional IRT
- Standard Neural Net retrievals provide temperature, water vapor, relative humidity, and (with optional IRT) liquid profiles from the surface to 10 km

### **MP-2500A Portable Profiling Microwave Radiometer**

- 14 V band (51-59 GHz) factory-calibrated channels
- Measures oxygen band brightness temperatures
- Measures cloud base temperature and height with optional IRT
- Standard Neural Net retrievals provide temperature profiles from the surface to 10 km

### **MP-1500A Portable Profiling Microwave Radiometer**

- 21 K band (22-30 GHz) factory-calibrated channels
- Measures water vapor band brightness temperatures
- Standard Neural Net retrievals provide water vapor profiles from the surface to 10 km

All models share the same basic hardware platform and use the same software. Operation of the three models is the same except as noted in this manual. Throughout this manual, the term “profiling radiometer” is used to refer to all models of the Radiometrics family of advanced portable profiling radiometers, known as the “A Series”.<sup>2</sup>

### Optional VizMet-B Software Package

All profiling radiometers are now available with Radiometrics’ VizMet-B software package. VizMet-B turns the Control Computer into a powerful web server, providing interactive access to the instrument from any remote computer connected by LAN or the Internet.<sup>3</sup> With the optional VizMet-B software installed on the Control Computer, authorized users can log in and configure, control, calibrate and monitor all aspects of the instrument operation, from anywhere, without installing any special software on the remote computer. The VizMet-B color GUI simplifies and automates the configuration, control, and calibration of the instrument. The 2D and 3D color graphics provide a running 72-hour “quick look history” of the level1 and level2 data products.

#### Use of this Manual:

- If the VizMet-B software package has been installed, refer to the separate document, **VizMet-B User’s Guide**, for information about operating the profiling radiometer with the VizMet-B GUI. For further information about VizMet-B, refer to **Appendix D**.
- If the VizMet-B software package has not been installed, the single user GUI described in this manual must be used to configure, control, calibrate and monitor the operation of the profiling radiometer.

The single user GUI can be used in two modes as described in detail in Section 5.1:

- Manual Mode
- Scheduled Mode

When the Operating Code is first started in Manual Mode, it performs an automated power-on self-test, and then presents a menu of options. The user may choose to begin automatic operations immediately using: (1) one of several factory-supplied “Procedure Files”, (2) a previously saved user-defined Procedure File, or (3) an automated liquid nitrogen (LN2) calibration may be selected.<sup>4</sup> Procedure Files contain a list of high-level commands that can be scheduled to execute at specific absolute times, or executed sequentially without any delay between commands (relative times).

<sup>2</sup> The A-Series replaces the 1<sup>st</sup> generation family of profilers: Models **TP/WVP-3000**, **TP-2500** and **WVP-1500**.

<sup>3</sup> The VizMet-B software package uses Java technology to enable any modern Windows, Mac, Unix, or Linux computer to connect and display the GUI. Remote computers require only a browser (e.g., Chrome or Firefox) and Java.

<sup>4</sup> As discussed in detail in later sections, liquid nitrogen (LN2) is used seasonally with an external calibration target to calibrate the internal Noise Diodes (ND) used operationally for continuous system gain measurements.

Once an option is selected from the menu, the Operating Code begins logging data to level0 files (raw sensor data in volts), level1 files (brightness temperatures), level2 files (profile retrievals), and TIP<sup>5</sup> calibration data files. Real-time graphics of the level1 and level2 products, related to the specific option selected, can be displayed. Real-time graphics for the MP-3000A include:

- Met Sensor time series (level1 data)
- Brightness Temperature time series (level1 data)
- Temperature, Water Vapor, Liquid Water, and Relative Humidity (RH) Profiles and column integrated vapor and liquid (level2 data)
- TIP calibration derived values of Noise Diode Temperatures (Tnd\_TIP)
- LN2 calibration derived values of Noise Diode Temperatures (Tnd\_LN2)

The Operating Code can also be programmed to run automatically under the Windows Operating System Task Scheduler (“Scheduler”). Typically, Procedure Files used with the Scheduler contain all the commands required for a 24-hour observing period, and the Scheduler is used to schedule automated relaunch of the Operating Code run every day at 00:00 UTC, using a specified Procedure File. Scheduled this way, the profiling radiometer Operating Code will produce continuous 24-hour data sets indefinitely, without user intervention. The System Task Scheduler is further discussed in Section 5.1.2 of this manual.

The Operating Code translates the high-level commands contained in the selected Procedure File into a series of detailed commands that are sent to the profiling radiometer.

Procedure File commands are described in Section 5.2.2 of this manual.

---

<sup>5</sup> The term “TIP” is used herein to refer to the TIP calibration method widely described in the literature, wherein the radiometer antenna is tipped to several elevation angles to calibrate the radiometer gain standards (Noise Diodes).

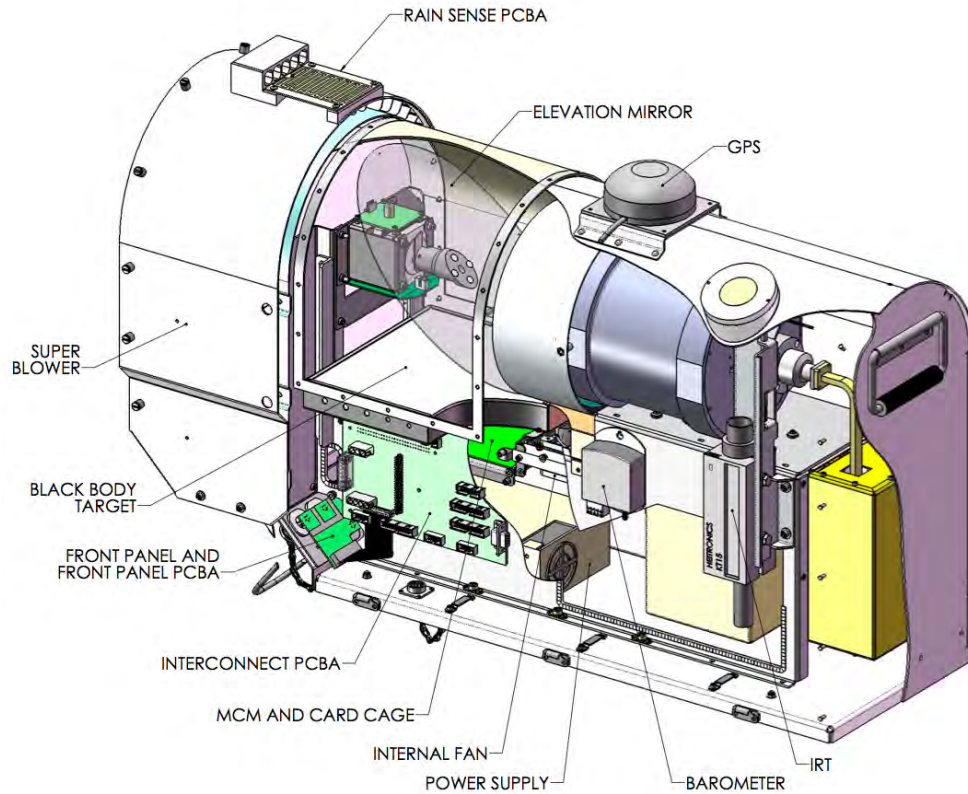

**Figure 1-2. MP-3000A cut-away diagram**

A cut-away diagram of the profiling radiometer is shown Figure 1-2. Liquid water on the antenna Radome (also referred to as the “microwave window”) can cause errors in the observed brightness temperatures. To minimize such errors, the profiling radiometer Radome is made hydrophobic to repel liquid water, and a special blower system (the Superblower) is used to sweep water beads and snow away from the Radome. The ambient temperature and relative humidity sensors are integrated in the inlet of the blower system to ensure a steady flow of ambient air over the sensors. A rain sensor is mounted on the top of the blower system. The ambient barometric pressure sensor is located inside the cabinet. The optional IRT is mounted inside the cabinet and views the sky through a user replaceable low-loss window in the cabinet.

## 1.2 Instrument Specification

| Function or Parameter   | Specification  |
|---|--|
| Calibrated Brightness Temperature Accuracy <sup>6</sup>   | $0.2 + 0.002 *  T_{kBB} - T_{sky} $ <sup>7</sup>                       |
| Long Term Stability   | <1.0 K / yr typical  |
| Resolution (depends on integration time) <sup>8</sup>   | 0.1 to 1 K   |
| Brightness Temperature Range <sup>9</sup>   | 0-400 K  |
| Antenna System Optical Resolution and Side Lobes<br>22-30 GHz<br>51-59 GHz  | 4.9 - 6.3° -24 dB<br>2.4 - 2.5° -27 dB                                 |
| Integration Time (user selectable in 10 msec increments)  | 0.01 to 2.5 seconds  |
| Frequency Agile Tuning Range (Accuracy = $\pm 2 * 10^{-6}$ )<br>Low Water Vapor Band (MP-1500A & MP-3000A)<br>Oxygen Band (MP-2500A & MP-3000A)<br>Minimum Frequency step size (K band; V band) | 22.0 – 30.0 GHz (K band)<br>51.0 – 59.0 GHz (V band)<br>10; 20 MHz     |
| Standard calibrated channels<br>MP-3000A<br>MP-2500A<br>MP-1500A  | 35<br>14<br>21   |
| Pre-detection channel bandwidth (effective double-sided RF bandwidth)   | 300 MHz  |
| Surface Sensor Accuracy<br>Temperature (-50° to +60° C)<br>Relative Humidity (0-100%)<br>Barometric pressure (600 – 1100 mb)<br>IRT <sup>10</sup> (Note: $\Delta T = T_{ambient} - T_{cloud}$ ) | 0.5° C @ 25° C<br>2 %<br>$\pm 0.5$ mb<br>$(0.5 + .007 * \Delta T)$ ° C |
| Brightness Temperature algorithm for level1 products  | 4 point nonlinear model  |
| Retrieval algorithms for level2 products  | Neural Networks  |

<sup>6</sup> Specified accuracy for instrument calibrated with an external target with no error.

<sup>7</sup> Absolute accuracy is best for sky brightness temperatures close to ambient, such as for the highest V band channels, and degrades as the absolute difference between the black body reference and sky temperatures increases.

<sup>8</sup> Typical resolution for 250 msec integration time is 0.25 K.

<sup>9</sup> Wider ranges are available. 0-400K is optimum for meteorological applications.

<sup>10</sup> The IRT is optional on all profilers. The standard Field of View (FOV) = 5°. Other lenses are available.

| <b>Function or Parameter</b>   | <b>Specification</b>  |
|--|---|
| Calibration Systems<br>Primary standards<br>Operational standards  | LN2 and TIP methods<br>Noise Diodes + ambient Black Body Target       |
| Environmental Operating Range<br>Temperature <sup>11</sup><br>Relative Humidity<br>Altitude <sup>12</sup><br>Wind (operational/survival) | -40° to +45° C<br>0-100 %<br>-300 to 3000 m<br>30 m/s / 60 m/s        |
| Physical Properties<br>Size (H x W x L)<br>Mass  | 86 x 53 x 31 cm<br>27 kg (with IRT)                                   |
| Power requirement (100 to 250 VAC @ 50 – 60 Hz)  | 200 watts typical<br>(Tamb = +25° C)<br>400 watts max at “cold start” |
| Data Interface<br>Primary computer port<br>Auxiliary port<br>Standard cable length <sup>13</sup>   | RS-422   57600 kb/s 8N1<br>RS-422   1.2 - 57600 kb/s 8N1<br>30 m      |
| Data File Formats  | ASCII CSV<br>(comma separated variables)                              |

**Table 1-1. Instrument specifications**

### **1.3 Profile Retrievals from Observations**

Extensive analysis indicates that artificial neural networks outperform other methods for retrieving water vapor, cloud liquid water, and temperature profiles from radiometric data. The profiling radiometers therefore use this mathematical inversion method for profile determination. Neural networks supplied by Radiometrics are derived using the Stuttgart Neural Network Simulator and a history of radiosonde profiles. A standard back-propagation algorithm is used for training, and a standard feed-forward network is used for profile determination. Profiles are output at 58 height levels, starting with 50 m steps from the surface up to 500 m, then 100 m steps to 2 km, and 250 m steps from 2 to 10 km.

<sup>11</sup> A high operating temperature option is available to extend operational temperature to +50 C. Contact Radiometrics for details.

<sup>12</sup> The optional wide range pressure sensor (500-1060 mb) is required for operation above ~1600 m.

<sup>13</sup> The 30 m length is standard. RS-422 communications cable lengths up to 1000 m are available by special order.

Although the number of independent measurements (eigenvalues) is less than the 58 retrieved layers, the finer “resolution” provides better displays and easier processing in subsequent data processing steps. This hyperspectral sampling also produces a more robust retrieval, via the presence of RFI, calibration errors, and heavy cloud/rain conditions. Above approximately 7 km, the atmospheric water vapor density and temperature approach the climatological mean values.

## **1.4 Radiometer Error Sources**

The operator should be aware of the following error sources:

- The Sun is a 6,000 K black body radiator. Therefore, K and V band Observations (3-6 degree beam width) should be avoided in directions within ~15 degrees of the Sun position, where error up to 60 K can result.
- Neural network retrieval algorithms are somewhat site dependent, especially for retrieval of water vapor and liquid water. The operator should ensure that the retrieval coefficients are representative for the observation site. Such retrieval coefficients are generated from a history of radiosonde (RAOB) data from a representative site.
- Liquid water on the profiling radiometer Radome can result in artificially high radiometer brightness temperature measurements. However, Radiometrics’ patented Rain Effect Mitigation (REM) system, which includes the Rain Sense PCBA, Hydrophobic Radome and Superblower, minimizes the accumulation of liquid water on the Radome and provides measurement capability during most precipitation events.
- Radio frequency interference (RFI) can cause “spikes” in the data. Although Radiometrics has implemented RFI protection throughout the systems, transmitters in the 22 to 30 GHz and 51 to 59 GHz regions can interfere with the profiling radiometer receivers. Observations are averaged to minimize this effect. However, spikes with a magnitude greater than several Kelvins can affect the accuracy of the retrieved profiles. The profiling radiometer should be installed in a location that is isolated or shielded from all strong radio transmitters.<sup>14</sup>
- Calibration error will degrade the inherent instrument accuracy. Noise Diodes provide an accurate, high stability operational gain reference, but only up to the accuracy of the primary standards used to calibrate them. Care should be taken when calibrating the Noise Diodes using either of the methods described herein. The internal ambient Black Body Target provides a means to calibrate the system temperature, from which the receiver temperature (Trcv) is derived. The receiver temperature is very stable, so observations of the Black Body Target can be relatively infrequent. To minimize Trcv error during periods of rapidly changing ambient temperature, receiver temperature calibrations should be performed every 5 minutes or more often.

---

<sup>14</sup> Note that Radiometrics’ patented frequency agile architecture uniquely provides the means to select RFI-free channels within each band to mitigate RFI problems, should they develop. If the user suspects RFI problems, contact Radiometrics for assistance in programming alternative frequencies.

- In all radiometers, the system gain fluctuates with “1/f noise”, resulting in added random noise in the observations. For typical integration times (~1 sec), 1/f noise can be dominant. All Radiometrics’ profiling radiometers use proprietary calibration methods and transfer function to virtually eliminate 1/f noise contributions.

## 2 Profiler Hardware Description

### 2.1 System Architecture

All profiling radiometer models share a common modular architecture. The block diagram in Figure 2-1 provides an overview of the primary system level components in the MP-3000A. All system level components are plug-compatible and factory interchangeable for ease of maintenance and repair. Most are also field replaceable units (FRUs).

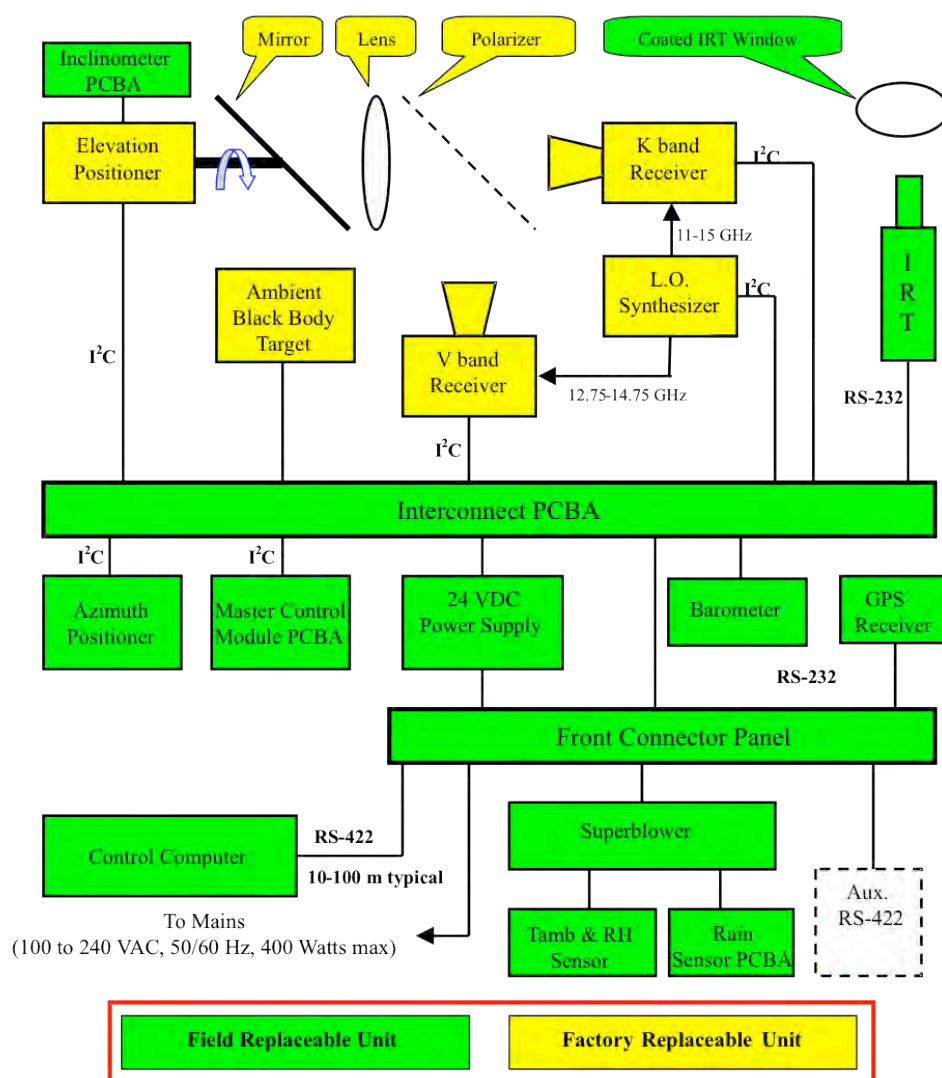

Figure 2-1. MP-3000A block diagram



The MP-2500A is identical to the MP-3000A except that it does not include the K band receiver. The MP-1500A does not include a V band receiver. Note that the Azimuth Positioner and IRT are optional components available on all models.

## ***2.2 Functional Description of Components***

Primary power enters the instrument through a twist-lock connector on the Front Connector Panel and is routed to the 24 VDC power supply. Primary power is controlled by a toggle switch on the left side. A single fuse on the Front Connector Panel protects the instrument from most electrical problems originating from the main supply lines. DC power is supplied to all components from the 24 VDC power supply, which is the only component that connects to primary power. A 26-conductor ribbon cable connects all Front Connector Panel connectors (except primary power) to the Interconnect Printed Circuit Board Assembly (PCBA). The two RS-422 ports on the Front Connector Panel have 2000V optical isolation incorporated on the backside of the Front Connector Panel PCBA. The Interconnect PCBA serves as a power and communications distribution hub. All the primary components plug in to the Interconnect PCBA.

The Superblower supplies high volume airflow over the Radome for Rain Effect Mitigation. A field replaceable HC2-S3 ambient temperature and RH sensor is mounted in the air intake of the Superblower, thus assuring both minimal solar bias and robust aspiration of the sensor. Digital communication between the HC2-S3 sensor and the Master Control Module (MCM) PCBA eliminates noise and offset error common to analog sensors. A field replaceable Rain Sense PCBA is mounted on the top of the Superblower.

A Field Replaceable GPS Receiver is mounted on the top of the cabinet and connected to the Front Connector Panel via RS-232 cable. The GPS Receiver supplies Time, Date and Position data to the MCM. The Control Computer uses GPS data to maintain the accuracy of the Windows System Clock, and to place a position stamp in the data files.

The MCM controls all the other components in the radiometer. It consists of a microprocessor, logic circuits, analog circuits, and voltage regulators. The MCM is a Field Replaceable Unit (FRU). The firmware can be upgraded in the field with a laptop, or via Internet if the Control Computer is connected to the Internet. The MCM communicates with the Control Computer via an optically isolated RS-422 cable, responding to high-level Control Computer commands with status and data as required.

The Control Computer is a Windows XP Pro computer with Radiometrics Operating Code and ancillary applications preinstalled. Users communicate with the instrument from the Control Computer using the Operating Code user interface. Normally, the user selects a factory- or user-defined Procedure, and the Control Computer executes it to sequence through a series of specified calibrations, sky observations and data processing events. Data is logged to files stored in the Operating Folder on the Control Computer, and accessible via LAN and the Internet (if connected and enabled by the user).

When the Control Computer issues a command to make a set of radiometric observations, the MCM points the antenna to the elevation and azimuth angles required. Then it sets the receiver local oscillator (synthesizer) to the first required frequency and commands the appropriate receiver to make the first observation. When the receiver completes the observation on the first frequency, the MCM commands the synthesizer to tune to the next required frequency and then commands the appropriate receiver to make the next observation. This sequence is repeated until all channels requested by the Control Computer have been observed. Then the data is sent from the MCM to the Control Computer.

The 45° Flat Mirror, 150 mm Lens and Polarizer, form the antenna beam. The Lens acts as a phase-correcting device that focuses plane wave fronts onto the phase center of the corrugated feed horns. Special baffles and absorbing collars are included to minimize errors due to side lobes and reflections. Antenna characteristics are summarized in Table 2-1.

| <b>Antenna Characteristic</b> | <b>22 GHz</b> | <b>30 GHz</b> | <b>51 GHz</b> | <b>59 GHz</b> |
|-------------------------------|---------------|---------------|---------------|---------------|
| Half power beam width         | 6.3           | 4.9           | 2.5           | 2.4           |
| Gain, dBi                     | 30            | 32            | 36            | 37            |
| Side lobes, dB                | < -23         | < -24         | < -26         | < -27         |

**Table 2-1. Antenna performance**

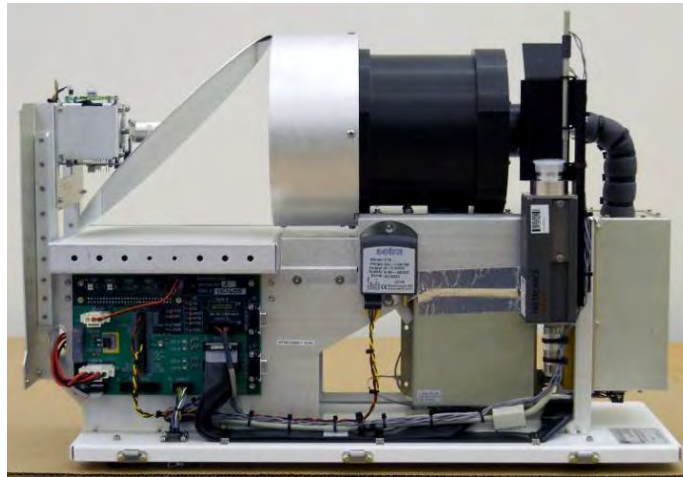

**Figure 2-2. MP-3000A Radiometer, internal view**

Incoming microwave energy passes through the Radome (not shown in Figure 2-2) and is reflected by the Mirror into the Lens, where the energy is focused on the microwave corrugated feed horns associated with each Receiver. The Polarizer (not shown) separates incoming microwave energy into two paths, passing the vertically polarized

waves straight through the grid to the K band horn, and reflecting the horizontally polarized waves down to the V band horn.

The Elevation Positioner can rotate the Mirror 360° to point the beam to any elevation angle. When pointed straight down (270°), the antenna points to the internal ambient Black Body Calibration Target. When the Control Computer sends a command to the MCM to calibrate the receivers, the MCM commands the Elevation positioner to 270° and collects a set of observations on all channels to be calibrated. The MCM sends the observation data and physical temperature of the ambient Black Body Target to the Control Computer where the receiver temperatures (Trcv) are calculated and logged.

A 2-axis inclinometer mounts on the top of the Elevation Positioner to measure the north-south and east-west instrument tilt angles. This provides the means to correct the elevation angles for any static offset due to instrument leveling error. The Elevation Positioner microprocessor digitizes the analog tilt values and sends them to the MCM.

The optional IRT Assembly (photo on the left) consists of the KT15.85-IIP IRT, mounting bracket, IR Black Body Target, a low-loss carbon-coated window and 2 temperature sensors. The IRT and window are field replaceable. The IRT communicates with the MCM via RS-232.

The optional Azimuth Positioner (photo on the right; bottom plate view) is installed between the instrument and the Tripod to provide full spherical coverage. It is powered and controlled by the instrument via a connector on the bottom of the instrument. With the Azimuth Positioner installed, the antenna can be pointed to any azimuth and elevation angle.

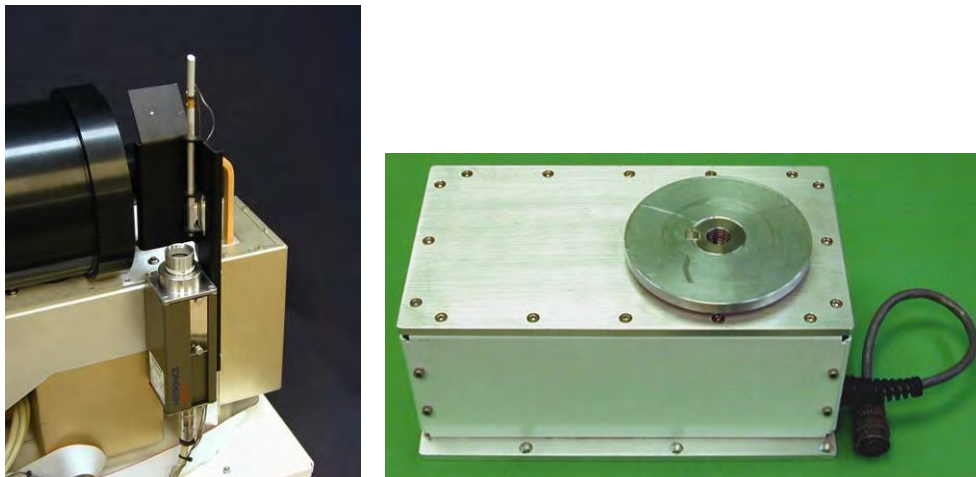

**Figure 2-3. Optional IRT Assembly (left) and optional Azimuth Positioner (right)**

### ***2.3 Detailed Description of Microwave Receivers***

The profiling radiometers utilize a single heterodyne, direct double sideband down conversion receiver architecture. All receivers are similar in architecture and

construction, except for the frequency ranges observed. Microwave channels are selected using a high stability frequency synthesizer with 1 MHz resolution to tune to any available channel in each band. There are 4001 available channels in the 22-30 GHz band and 2001 channels in the 51-59 GHz band. The resulting frequency agility is a patented feature of Radiometrics profiling radiometers, making them unique in their ability to scan many channels without the high cost and complexity of filter-bank technology. Standard receivers are supplied with 21 calibrated channels in the 22-30 GHz band and 14 calibrated channels in the 51-59 GHz band.<sup>15</sup> Any of the other available channels can be factory calibrated to meet specific customer requirements.

The ability to tune any in-band frequency also enables these profiling radiometers to emulate other microwave profilers for comparative measurements, or to transfer the calibration to other radiometers. For microwave communications link studies, sky brightness temperatures can be measured at any in-band frequency of interest.

The receivers accept input power from the antenna system and down convert the input spectrum to a common IF frequency band. The IF Module amplifies, filters and detects the signal. The square law detector output voltage is nearly proportional to system temperature (combined antenna and receiver noise). The detector output is amplified within the IF Module to a high level (1-2 V typical), low-pass filtered and then digitized by the Baseband Processor (BBP). Receiver frequency selection is accomplished by setting the desired local oscillator frequency in the L.O. Synthesizer. Each Receiver has a noise source (Noise Diode), used for system gain measurement, controlled by the BBP. The physical temperature of the microwave components is stabilized to ~30 mK RMS by Peltier devices controlled by a PID control loop in the BBP.

### 3 Installation

The profiling radiometer System includes the following items:

- Profiling radiometer instrument
- Control Computer with Operating Code<sup>16</sup>
- Power cable
- Communications cable
- Mounting Plate and T-Bolt (secures instrument to mount)
- Operator's Manual
- Spares, including misc. hardware, 2 Radomes, fuses and Superblower inlet filters
- Maintenance Tool Kit
- Reusable Hard Transport Case

In addition, the following options may be included:

---

<sup>15</sup> The 21 K and 14 V band calibrated channels include the 12 legacy channels used in older Radiometrics' models.

<sup>16</sup> Rugged outdoor mobile computer, UPS and NEMA4 enclosure are available.

- VizMet-B Webserver Software for remote access and advanced features
- TP-2000 Telescoping Tripod<sup>17</sup>
- KT15.85-IIP IRT Assembly<sup>18</sup>
- Cryogenic LN2 Calibration Target<sup>19</sup>
- Azimuth Positioner
- High operating temperature option (extends operations to +50C)

Before starting the installation, check to verify that all required components are on hand. Notify Radiometrics and the transportation provider if any items are missing. To install the instrument, follow the steps below.

### 3.1 Site Selection

Select a suitable site for the profiling radiometer and the Control Computer. The profiling radiometer can be set up on the ground (concrete, asphalt, or other firm surface), or on the roof of a building. When selecting a site, it is important to consider the following factors:

- It is essential to select a site where the antenna field of view will not be obscured or contaminated by earth surface features, such as mountains, trees, buildings, etc. The antenna elevation angle changes during normal operation from near the horizon in one direction to near the horizon in the opposite direction. Orient the radiometer to provide a clear field of view when the mirror is pointed off-zenith to either side of the instrument; this can best be understood by referring to the MP-3000A cut-away diagram in Figure 1-2. For best TIP calibration performance, the radiometer should have a clear field of view to 25 degrees above the horizon in each direction. To prevent earth surface radiation from contaminating the TIP calibration, ensure no surface feature above 5 degrees in elevation angle is within 20 degrees of the elevation steering plane. If the optional Azimuth Positioner is installed, then there should be no surface feature above 5 degrees in elevation angle for all azimuth angles of interest.
- The site must have a solid surface for mounting and securing the Tripod. It is not necessary for the surface to be level<sup>20</sup>, but it must be stable so that the instrument will remain level over time and changing wind load. Under strong wind conditions (>100 km/hr), the side loads are very high, producing high forces on the legs. The best way to ensure the integrity of the system under strong wind conditions is to use both a) the center-pull-z, and b) the bolts in the Tripod feet. See **Appendix A** and Figure 3-1 for details.

---

<sup>17</sup> Recommended for most installations. If the Tripod is not used, customer must provide an equivalent level mount.

<sup>18</sup> Recommended for all MP-3000A instruments. Required for MP-3000A cloud-base determination.

<sup>19</sup> Optional for the calibration of the MP-1500A. Required for the calibration of all other models. One target can be used for all instruments at one location.

<sup>20</sup> Level the instrument by adjusting the Tripod leg length. Therefore, the Tripod can be mounted on a moderately uneven or sloped surface.

- Access to the instrument will be necessary for maintenance. A site should be chosen that provides security from unauthorized persons, while making for convenient access for maintenance.
- The standard power cable is 30 m long. Longer cables can result in low voltage. Therefore, primary power should be available within 30 m. If power is not available within 30 m of the preferred site, a new primary power circuit should be installed rather than using long extension cords.
- The standard RS-422 data cable is also 30 m long. If the Control Computer needs to be located more than 30 m from the instrument, a cable made to any custom length up to 100 m may be ordered. For longer distances, consult the factory for advice. In these cases, it may be better to pull the cable through conduit first and add connectors in the field.
- The surface meteorological sensors are high-performance devices, but the data can be biased by local sources of air contaminated by roof top exhaust vents, nearby roads, etc. Therefore, the profiling radiometer site should be separated a reasonable distance from all local sources of contaminated air.
- The profiling radiometer uses one or more sensitive, wideband microwave receivers. To minimize the risk of contamination from radio transmitters, a chosen site should be free of all in-band radio frequency interference greater than  $-144$  dBm/MHz (30 dB below kTB). Out-of-band interference can also result from HF, VHF, UHF or microwave transmitters very near the profiling radiometer.

### **3.2 Site Preparation**

Once sites have been selected for the profiling radiometer and the Control Computer, make provisions for the chosen Tripod anchoring technique and routing of cables. If the installation will be permanent, consider using conduit pipe(s) for the cables. Conduit will help protect the cables from rodent damage, moisture and lightning induced transients. A low-impedance earth ground should be connected to the Tripod at any convenient attachment point (customer provided equipment).

### **3.3 Assembly and Setup**

The Model TP-2000 telescoping aluminum Tripod is typically furnished with the profiling radiometer. The Tripod is shown in Figure 3-1 with a MP-3000A radiometer and optional Azimuth Positioner mounted. Detailed Tripod assembly instructions are included in **Appendix A**.

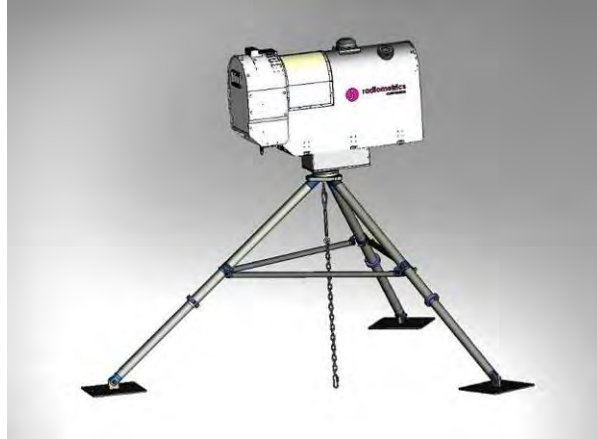

**Figure 3-1. Tripod and anchor chain with profiling radiometer**

## **CAUTION**

**Only lift the instrument by its handles or base. Radiometrics strongly recommends having two people to mount the radiometer on the Tripod.**

### **NOTE:**

The instrument cover contains a foam dielectric hydrophobic Radome. Only use the lifting handles to support or lift the radiometer. Abrasive contact and foreign matter degrade the hydrophobic Radome. Do not intentionally touch it.

### **3.4 Leveling the Tripod**

Before installing the profiling radiometer, the Tripod mounting plate must be leveled using the bubble level supplied with the TP-2000 Tripod (or similar). The instrument must be mounted on a level mounting plate to ensure accurate antenna elevation angles and TIP calibrations. If the triangular mounting plate is not level within 1/8<sup>th</sup> of a bubble in all directions when the Tripod is in position at the installation site, adjust one or more of the telescoping Tripod legs to different lengths as required to make it level.

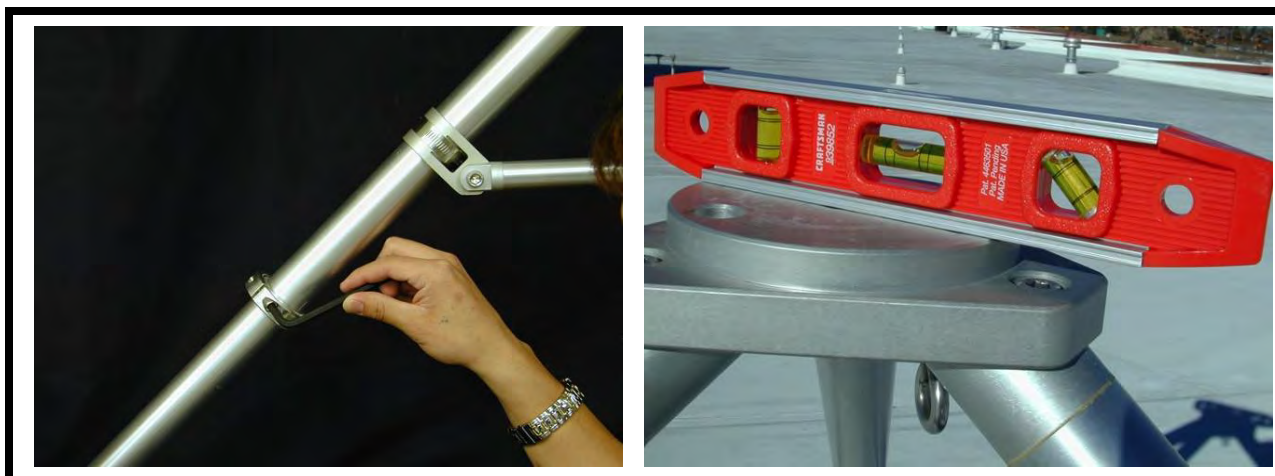

**Figure 3-2. Leveling the TP-2000 Tripod**

1. Align the level in the plane of the leg to be adjusted first.
2. Then loosen the leg collar clamp on that leg using the 1/4" Allen wrench as shown in Figure 3-2.

The lower leg will slide freely inside the upper leg. To adjust the leg length, move the lower leg up or down as necessary.

3. When the bubble in the level is centered, tighten the collar clamp.
4. Repeat for each leg as necessary to make the triangular mounting plate level in all directions.

Refer to Figure 3-3, for a quick leveling reference.



**Figure 3-3. Leveling directions**

**NOTE:**

Exercise reasonable care when assembling the Tripod to avoid denting or damaging the Tripod legs. Dents in the legs will prevent the inner tube from being extended/shortened.



### 3.5 *Securing the Tripod*

Secure the Tripod to the ground or building roof using one of the methods recommended in **Appendix A**. The supplied center-pull anchor chain and turnbuckle assembly provides a robust way to secure the Tripod to the surface below using a single eyebolt. This method is especially useful when the height may need to be adjusted from time to time. The addition of anchor bolts in the feet is advised if the height and location are permanent. After securing the Tripod, check to make sure it is still level, as secured. If the Tripod is not level within 1/8<sup>th</sup> bubble, loosen the chain and/or foot security bolts/stakes as required, and refine the leveling as described in Section 3.4, and then retighten all fasteners.

### 3.6 *Mounting the Profiling Radiometer*

**NOTE:**

Before proceeding with this step, if the center-pull method is used to secure the Tripod, loosen the chain temporarily, as necessary, to turn the T-Bolt to mount the profiling radiometer.

Using the lifting handles located on each end of the profiling radiometer, lift the profiling radiometer from its shipping container. If the optional Azimuth Positioner is to be installed, follow the separate instructions supplied in **Appendix G** to install it on the bottom of the profiling radiometer. Place the profiling radiometer (with Azimuth Positioner if installed) on the Tripod mounting plate and secure with the 5/8-11 T-Bolt. The Front Connector Panel should be oriented due east.<sup>21</sup> If the center-pull chain was loosened, retighten the chain.



**Figure 3-4. Securing the profiling radiometer with the T-Bolt**

---

<sup>21</sup> If the optional Azimuth Positioner is not installed, orienting the Front Connector Panel due east will result in elevation angle pointing in a north-south plane, with 0 degrees elevation due north, 90 degrees zenith and 180 degrees due south. If the user prefers a different elevation-scanning plane, adjust the azimuth accordingly.

### 3.7 Attaching the Power Cable

To ensure safe operation, the power cable must be connected to a properly grounded receptacle. The power cable is normally supplied with a connector pre-installed for the receptacles used in the region to which the profiling radiometer is delivered.

Always disconnect the power cable from the power supply before disconnecting the cable from the profiling radiometer. This ensures ground integrity in case of a fault condition. Only qualified personnel should service the profiling radiometer. Hazardous voltages are accessible between the Front Connector Panel and the Power Supply after removal of the cabinet hood.



**Figure 3-5. Power cable supplied by Radiometrics**

Locate the Front Connector Panel, shown in Figure 3-6, at the base of the profiling radiometer and below the Superblower.



**Figure 3-6. Front Connector Panel**

With the power switch in the **OFF** position, mate the power cable plug and secure by rotating the locking collar into the detents. Connect the other end of the power cable to the commercial power receptacle. The profiling radiometer can be protected from power failures by utilizing an uninterruptible power supply (UPS). The power cable should be connected to a grounded receptacle for safety, as well as static and transient protection.

### **3.8 Attaching the Data Cable**

The RS-422 Data Cable (shown in Figure 3-7) connects the profiling radiometer to the Control Computer. This cable has an RS-422 to USB converter on the Control Computer end.

Plug the USB connector into any available USB port on the Control Computer. Drivers for the USB adaptor are preinstalled. Plug the circular connector end of the RS-422 data cable into the profiling radiometer RS-422 port labeled **Computer RS422**.

#### **NOTE:**

An auxiliary RS-422 port is furnished for special applications. Due to the wide variety of protocols that RS-422 connected devices use, the standard Operating Code does not support the use of this port. Contact Radiometrics for information on custom versions of the Operating Code if the use of this port is desired.



**Figure 3-7. Data cable**

### **3.9 Securing the Cables**

Secure the cables to a Tripod leg using tie wraps or Velcro straps (from cable set). If the optional Azimuth Positioner is installed, provide a service loop in the cable bundle so that it does not restrict motion when changing the profiling radiometer azimuth position.



Figure 3-8. Cable service loop for use with Azimuth Positioner

### 3.10 Installing the Control Computer

Radiometrics preinstalls on the Control Computer all software and files required for the normal operation of the profiling radiometer. **Substituting another computer for the unit supplied by Radiometrics, or changing the factory software load and settings, may void the Radiometrics Warranty Support Obligation. If such changes cause need for Radiometrics remote support, Radiometrics will invoice these services at our normal hourly support rates.** The single-user Operating Code (mp.exe or similar) and all associated input files (configuration file, neural network files, Procedure Files) are stored in one folder referred to herein as the “Operating Folder”. The Operating Folder can have any name, and be located anywhere within the disk directory structure. As delivered from the factory, “shortcuts” (aliases) for the Operating Folder, Operating Code, Microsoft Notepad (**Notepad**) and Windows Task Scheduler are located on the desktop. All output files are stored in mp.exe the Operating Folder.

The Control Computer should be located in a suitably protected indoor environment. Connect the USB connector on the data cable to an available USB port on the left side. Normally, the RS-422 serial port driver is installed and associated with COM4 in the Windows XP Operating System. If a different serial port has been assigned to the RS-422 adaptor, then the associated com port should be specified in the configuration file (mp.cfg) to match the RS-422 serial port in use. To change the com port in the configuration file from the default value of 4, open the mp.cfg file using **Notepad**. Change the number defining the com port, then save the file.

## 4 Initial Operation and Test of the Instrument

To begin operating the instrument, locate the power switch on the Front Connector Panel of the profiling radiometer and move it to the **ON** (up) position. The Superblower will start. If installed, the optional Azimuth Positioner may turn to seek its index position, and the elevation stepper motor will be heard stepping to its index position. Once the profiling radiometer reaches its azimuth index position, it must be reoriented to align the antenna to the north-south observation plane. To align the profiling radiometer, loosen the T-Bolt slightly and gently rotate the profiling radiometer so that the Front Connector Panel points due east, and then retighten the T-Bolt. This alignment is only required the first time the profiling radiometer is turned on after installation, or after movement of the Tripod or profiling radiometer.

### NOTE:

Orienting the Front Connector Panel end of the instrument to the east sets the pointing direction of the mirror in a north-south plane, the reference plane for observations. Any error in this orientation will result in an equivalent error in azimuth pointing direction. The user may want to use a compass for this orientation. If so, the magnetic declination at the installed site must be included in the determination of true north.

### NOTE:

If the Superblower is not heard when power is first turned on, check the fuse in the Front Connector Panel (Figure 3-6) by turning the fuse cap counterclockwise, removing the fuse, and visually inspecting. If in doubt, use a Digital Volt Meter (DVM) set to continuity or resistance to test for continuity. If the fuse is good, check the power source with a DVM (set to AC voltage). If unable to determine the cause of the lack of power, contact Radiometrics for assistance.

### NOTE:

Before attempting to calibrate the instrument or collect data, the instrument must reach its stable operating temperature. If the profiling radiometer is initially in equilibrium with ambient air temperature, it will require up to 30 minutes for the microwave receivers to thermally stabilize (depending on the ambient temperature). Immediately following the movement of the profiling radiometer from one environment to another (e.g., from a warm warehouse to cold outdoors), then up to 5 hours may be required for the profiling radiometer to reach complete equilibrium. The profiling radiometer may be operated safely during the period it is stabilizing, but the data may be unusable or unreliable.

Locate the Control Computer power switch and turn it on. The computer will start and the Windows XP Pro Desktop will appear on screen.<sup>22</sup>

**To start the Operating Code, double click the Operating Code shortcut icon on the Windows XP Pro Desktop. This will load the profiling radiometer program (mp.exe). Diagnostic tests will be automatically performed immediately. Then the**

---

<sup>22</sup> If VizMet-B has been installed, the radiometer will automatically begin operation after turning on the control computer. See **Appendix D: VizMet-B User's Guide** for details.

**Control Computer will display an array of small housekeeping data graphs (sometimes referred to as “engineering data”) that indicate the state of the instrument.**

Figure 4-1 shows the display following a successful power on test of the MP-3000A. When the graphs of Tknd0 (K band noise diode physical temperature) and Tknd1 (V band noise diode physical temperature) stabilize at  $323.15 \pm 0.1 \text{ K}$  (+50.0C), the receivers have reached thermal stability, and observations can be started.<sup>23</sup> (Note: The MP-1500A and MP-2500A single band profiling radiometers only display information for one receiver, rcvr0).

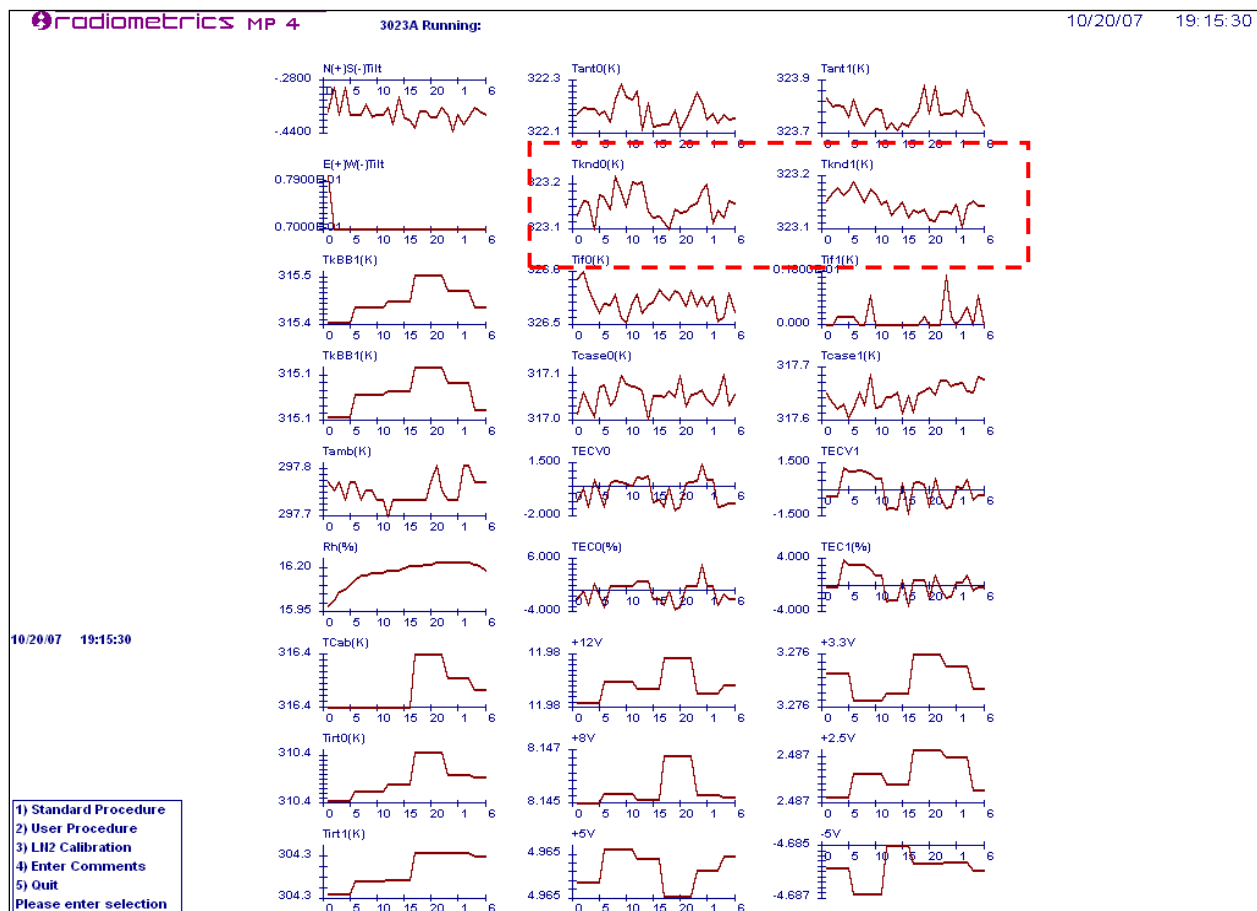

**Figure 4-1. Operating Code display after power-on tests have completed**

**NOTE:**

If the cursor is moved to the lower edge of the screen while in Windows XP, the full-screen display will change to a windowed display with scroll bars at the side and bottom

<sup>23</sup> The normal receiver operating temperature is factory set to +50C but may be changed at the factory for special cases.

of the screen. Other programs can then be selected from the bottom tool bar. To return to full screen, press **Alt-Enter**.

The main menu is displayed in the lower left corner of , and enlarged in Figure 4-2 below.

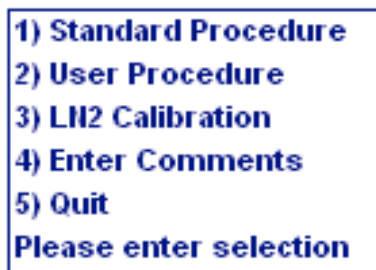

**Figure 4-2. Main menu screen**

From the main menu, the user may select from the following five options:

|                       |   |
|-----------------------|---|
| 1. Standard Procedure | Select from a list of standard factory-supplied procedures.                             |
| 2. User Procedure     | Select from a list of previously written user-defined procedures.                       |
| 3. LN2 calibration    | Perform an LN2 user calibration with the external Cryogenic Target.                     |
| 4. Enter Comments     | Enter a brief note (free-form text) that will be appended to the next level0 data file. |
| 5. Quit               | Make the Operating Code terminate execution after an orderly shutdown.                  |

**Table 4-1. Main menu options**

**NOTE:**

The radiometer may be operated immediately after installation, but it should be recalibrated before “official” data collection begins, and after any transport.

To begin observations immediately using the Manual Mode and a factory-preconfigured procedure, choose option 1 (press the “1” key). The next screen will display the available standard procedures one at a time by scrolling through the list using the “<” and “>” keys.

Scroll to the procedure named “TEST1.prc” and press “Enter” to begin. TEST1.prc is a procedure that will exercise most of the instrument observation functions. For the MP-3000A, TEST1.prc does the following:

- logs 48 housekeeping data values, including the GPS time, date and position
- performs a 35-channel receiver temperature calibration and a 21-channel TIP calibration
- observes all 35 zenith brightness temperatures
- performs a 26-input neural network retrieval<sup>24</sup>

After a few observation cycles, the screen will display a set of real-time graphics similar to those in Figure 4-3. The user may toggle the between the three screens illustrated in Figure 4-3, Figure 4-4 and Figure 4-5 below to see views of level1 data, level2 data and TIP calibration data. Toggle the screens by pressing the **1**, **2** and **T** keys:

- **1** View brightness temperatures for all channels
- **2** View profiles of temperature, RH, vapor and liquid, and time series of integrated vapor and liquid
- **T** View TIP calibration derived values of Tnd

---

<sup>24</sup> Radiometrics frequently updates and changes procedure files. If the radiometer Operating Directory has been updated, this procedure file may not be present. If the procedure TEST1.prc is no longer available, try any other procedure that performs periodic retrievals. See Section 5.2.2 for information on generating procedures.



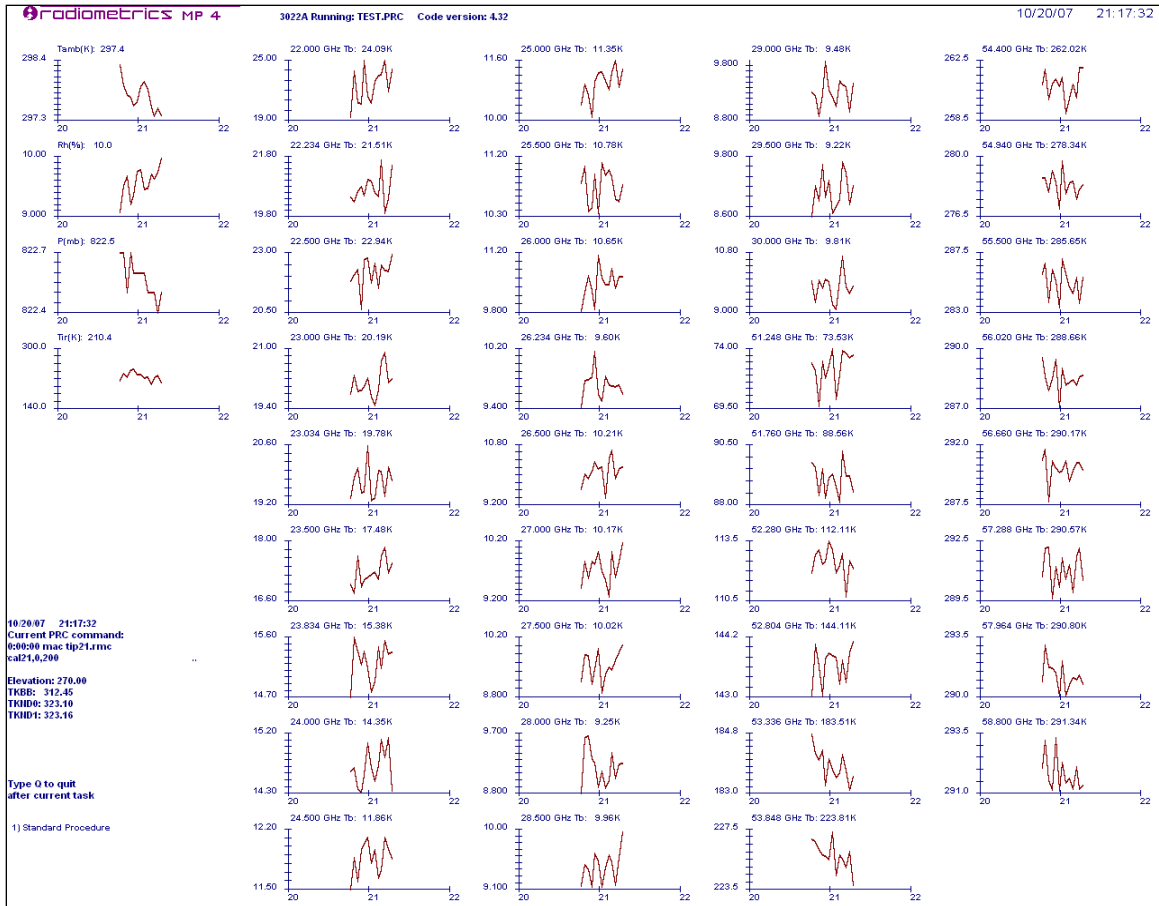

Figure 4-3. Key 1 for level1 data (brightness temperature)

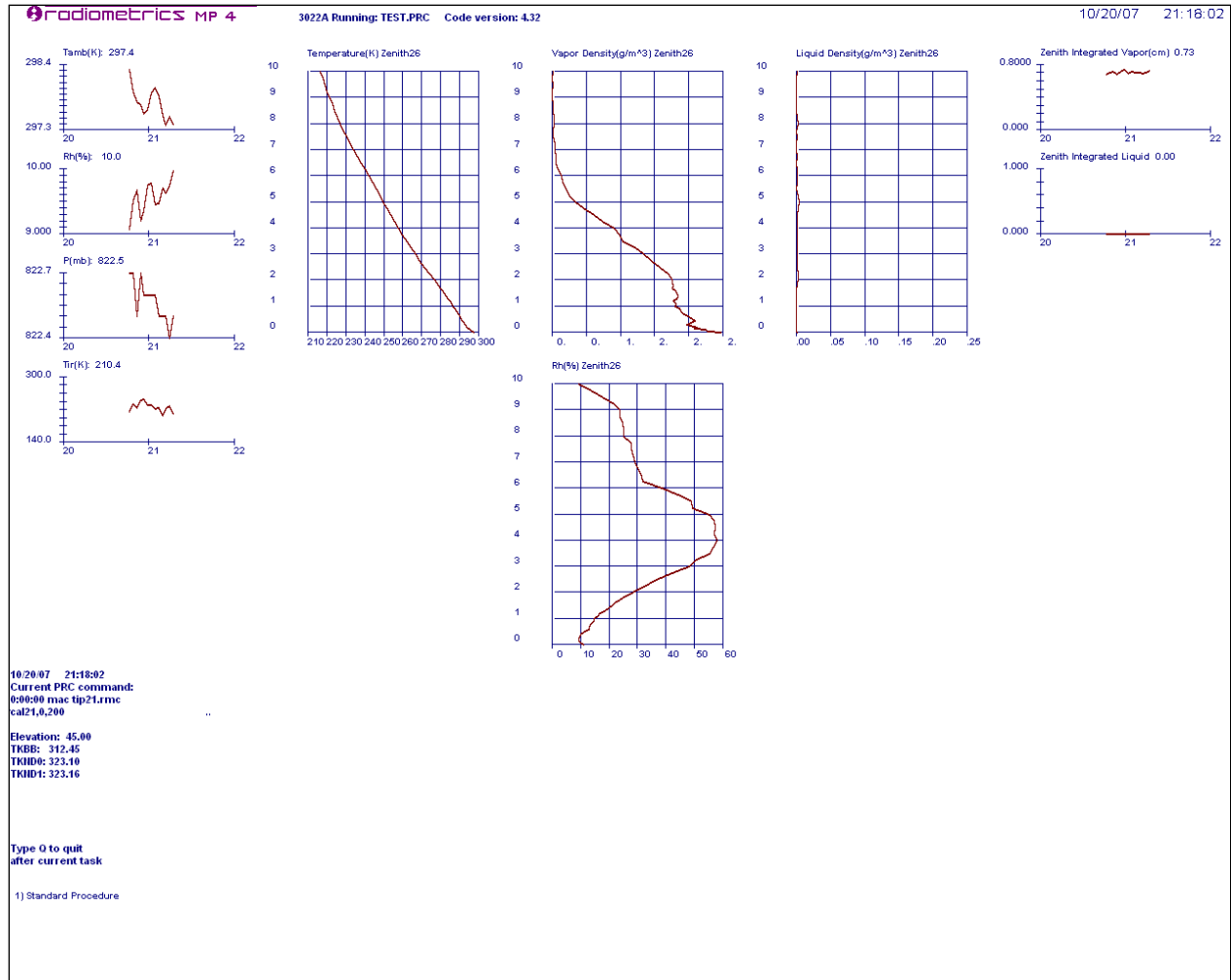
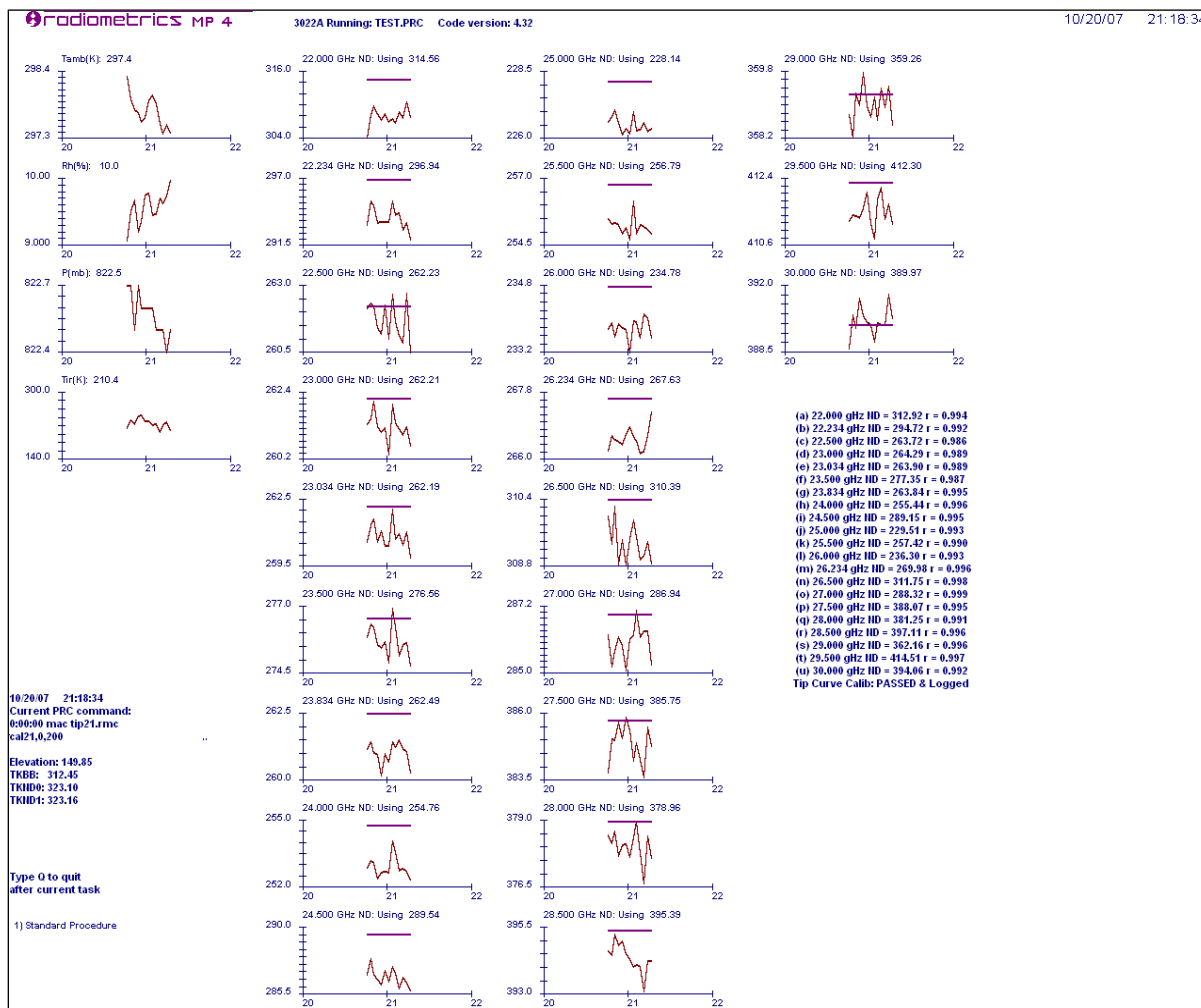

Figure 4-4. Key 2 for level2 data (profiles and integrated values)



**Figure 4-5. Key T for TIP calibration display: K band noise diode calibrations**

**NOTE:**

The availability of 1, 2 and T displays will depend on the procedure file used.

For the limited purpose of this initial test, it is sufficient to verify that the instrument and software produce displays similar to those viewed above. To terminate the test, press the “Q” key. This causes the Operating Code to stop in an orderly manner after completing the current observation. Section 6 provides a more detailed description of the operation of the instrument.

## CAUTION

**Ending the program by closing the window may corrupt data files.**

This completes the basic post-installation check and tests. Data files (Lv1 and Lv2) may be opened in Microsoft Excel to view and verify the data collected. To sort the data into

logical blocks with the appropriate header record associated with each logical block, in Excel select the entire worksheet and navigate:

**Data > Sort > Column C (record type)**

Plot data in the files produced by the test to help verify data consistency. Figure 4-6 is an example of level1 brightness temperature data plotted for observations on the 8 K band and 14 V band channels normally used for zenith profiles produced by the MP-3000A.

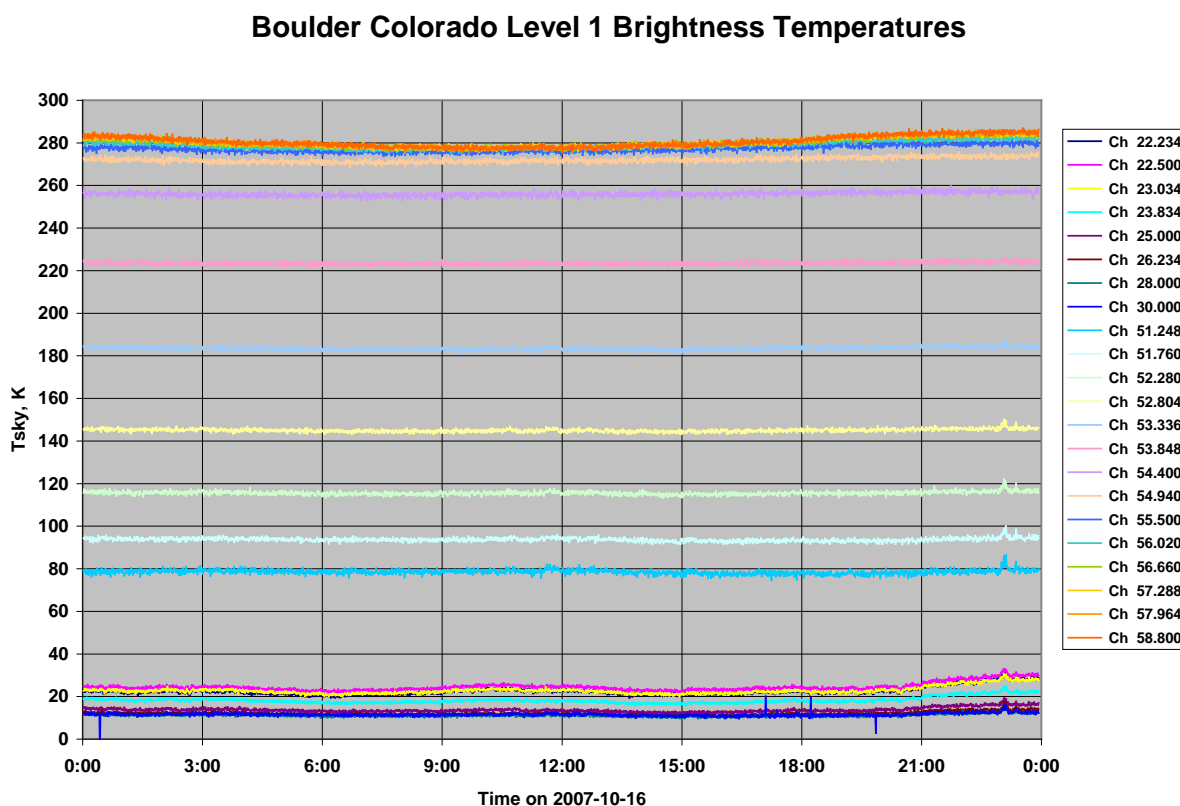

**Figure 4-6. Example of level1 brightness temperature time series plotted in Excel**

Detailed instructions for instrument configuration and operation begin at Section 5. Before beginning operations for the first time, users are urged to read Section 5 and **Appendix E** on radiometer calibrations. Even if the user chooses not to calibrate the profiling radiometer or Met Sensors at this time, the information contained in Section 5 provides part of the background required to choose the best configuration for operation of the instrument. For the highest accuracy observations, the instrument should always be recalibrated after transport.

## 5 Configuration, Control, and Data Processing

This section provides detailed information on the configuration and operation of the profiling radiometer. It builds on the definitions, procedures, and information introduced in Section 4 and **Appendix E** on radiometer calibrations. Users unfamiliar with the Operator Interface and basic commands should review those sections before proceeding with Section 5. In this section, the user will learn more about the Modes of Operation, Input Files used to configure and control the profiling radiometer, and Output files generated by the profiling radiometer.

### NOTE:

The optional VizMet-B software adds a powerful combination of web server and JAVA-based GUI technology. When installed, many of the procedures described herein are simplified or completely automated. Refer to the **VizMet-B User's Guide (Appendix D)** for information about the operation of the radiometer if VizMet-B has been installed. VizMet-B op-server is a high level supervisory program that runs the operating code for the user via a web based GUI. If VizMet-B software has been installed, but the user desires to control the operating code manually, VizMet-B op-server and certain Windows scheduled tasks must be disabled first. Refer to the **VizMet-B User's Guide (Appendix D)** for detailed instruction to disable VizMet-B.

### 5.1 Modes of Operation

Profiling radiometers can operate in either of two modes: **Manual Mode** or **Scheduled Mode**. Operated in Manual Mode, the Operating Code will continue to operate indefinitely until the manually selected Procedure File in use reaches the end of the procedure, or the user terminates operation with a **Q** command. In Scheduled Mode, the Operating Code starts automatically according to the Windows Task Schedule, using a procedure specified in the schedule. In this case, operation continues as scheduled until terminated by the operator. Procedures are ASCII text files that contain a list of commands as described in detail in Section 5.2.2.

#### 5.1.1 Operating in Manual Mode

The Manual Mode of operation is typically used for testing new user defined procedures, short-term data collection and LN2 user calibrations. To start the profiling radiometer in Manual Mode, double click on the Radiometer Shortcut Icon on the Desktop display.<sup>25</sup> This starts the Operating Code, after which the user may select from the five options listed in Figure 4-2. Use of Options 1, 2, 3, and 5 was described in Section 4. Option 4 is available during Manual Mode to annotate the level0 data file produced by the next procedure run. To add a free-form text notation to the next level0 file, press **4**. To complete the entry of each line of text, press the **ESC** key once. The line entered will disappear from the screen, but it will be added to the level0 file. Any number of lines can

---

<sup>25</sup> If the Radiometer Shortcut is missing from the Desktop, locate the Operating Code file (mp.exe or similar) in the Operating Directory and make a new Shortcut for the Desktop.

be typed, each entered by **ESC**. When the last line has been entered, press **ESC** twice to end the text input, and return to the Main Menu. Then select either option 1, 2 or 3 to proceed.

### 5.1.2 Operating in Scheduled Mode

The Scheduled Mode of operation is normally used for operational or continuous use. This mode of operation uses the Windows Task Scheduler. This section lists the scheduled task required for normal operation under VizMet-B and describes how to verify these tasks on the Control Computer. For information on Scheduled Task set up under VizMet-B, refer to **Appendix D**, VizMet-B Reinstall Instructions, of the Radiometrics Profiler Operator's Manual.

#### Overview

This section describes how to verify that scheduled tasks are correctly configured or VizMet-B in the Windows 7 environment. Below is a table that lists the batch files (\*.bat) and their related scheduled tasks.

| Bat File                                 | Task operation   | Time of Trigger            |
|--|--|----------------------------|
| <b>start_radiometrics_app_server.bat</b> | Runs the appserver Ruby script (.rb) for system startup.   | With system startup        |
| <b>forceful_stop.bat</b>                 | Runs the forceful_stop Ruby script (.rb) for an immediate stop, even in mid-procedure.                       | 11:59 pm daily             |
| <b>graceful_stop.bat</b>                 | Runs the graceful_stop Ruby script (.rb) for normal stopping.  | 11:56 pm daily             |
| <b>monthly_archiver.bat</b>              | Runs the monthly_archiver Ruby script (.rb) to put the month's data into a zip file for alternative storage. | End of month, 12:05 am     |
| <b>operational_server.bat</b>            | Runs the operational_server Ruby script (.rb) for task system startup.                                       | With system startup        |
| <b>restarter.bat</b>                     | Runs the restarter Ruby script (.rb) to control the radiometer restart and resumes whatever task was halted. | Restarts at 12:00 AM (UTC) |

**Table 5-1. Bat files**

#### Preparation

Read instructions fully.

**Special Tool Requirements:**

Control Computer with

- mp.exe operating code
- VizMet-B installed
- radiometer files in **operational\_server** folder

**Procedure**

1. In Windows 7, double-click the Task Scheduler shortcut, to open the Task Scheduler window. Refer to Figure 5-1.

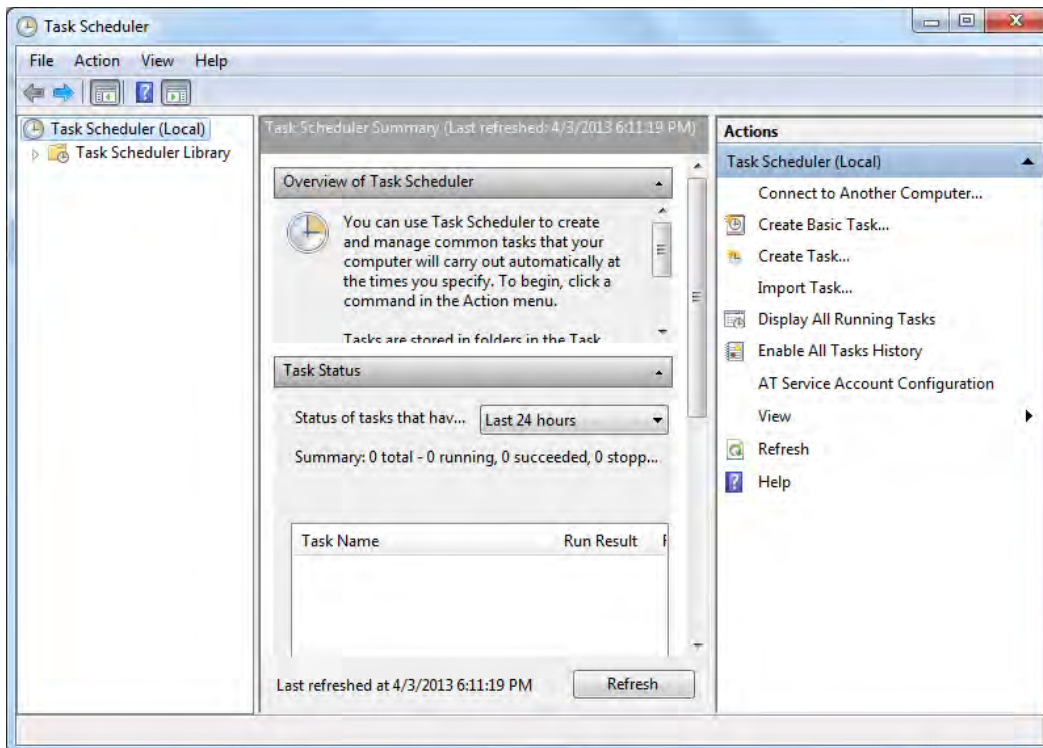
**Figure 5-1. Task Scheduler window**

2. In the left-hand pane, click the **Task Schedule Library**. The following list of scheduled tasks should appear, as shown in Figure 5-2.

- appserver
- forceful\_stop
- graceful\_stop
- monthly\_archiver
- opserver
- restarter

Ensure that the Trigger matches the “Time of Trigger” column in Table 5-1; correct as necessary.

If one or more tasks are missing, they must be recreated. The simplest method for creating missing scheduled tasks is to re-install VizMet-B. Refer to **Appendix D** for uninstalling and re-installing VizMet-B.

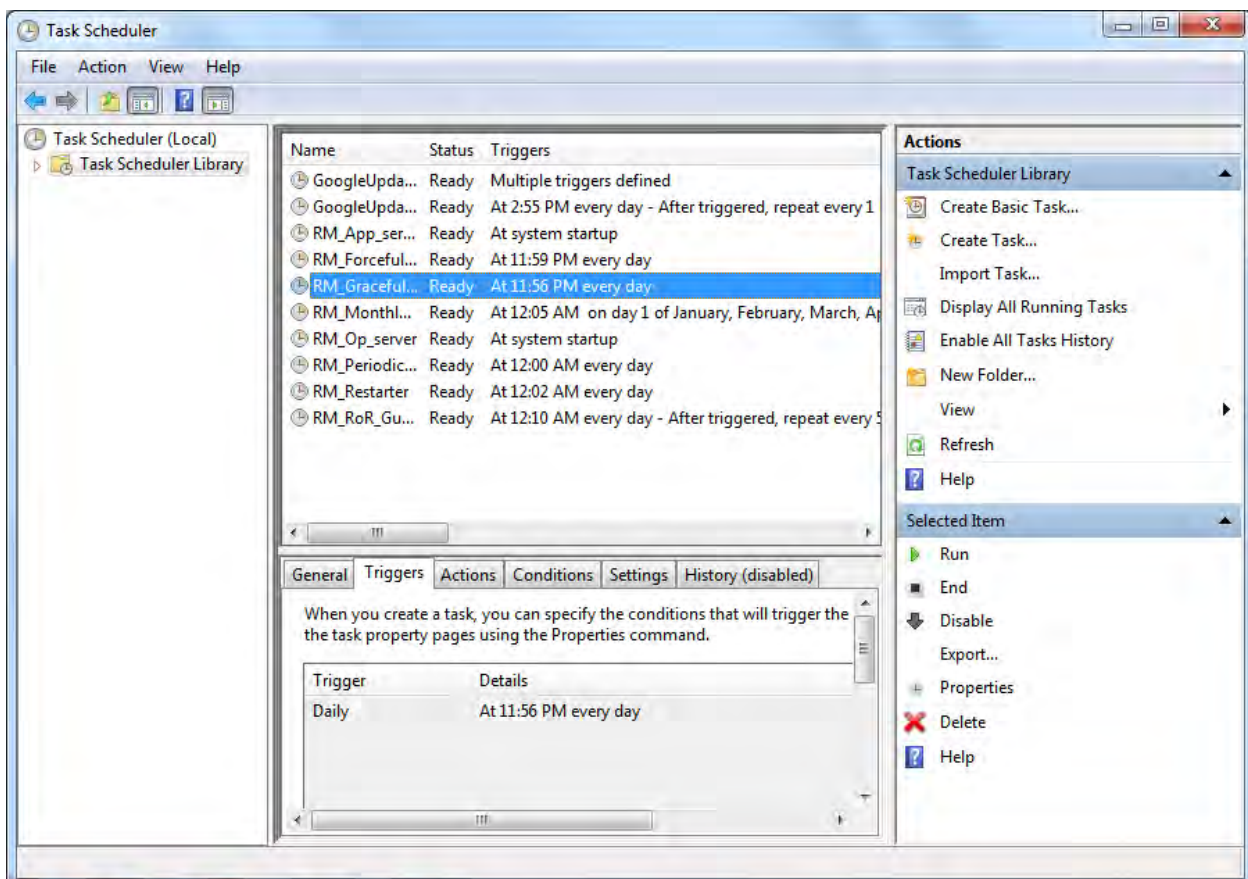

**Figure 5-2. List of Scheduled Tasks**



3. Within the **Task Scheduler** window, select a task to inspect its properties with the following tabs:

| Tab        | Function   |
|------------|--|
| Triggers   | Specifies the conditions that will trigger the task.   |
| Actions    | Specifies what action will occur when the task starts. |
| Conditions | Determines if the task will run.                       |
| Settings   | Specifies additional task behaviors.                   |

**Table 5-2. Tabbed properties of scheduled tasks**

4. To add or change properties, double-click a scheduled task. The scheduled task's Properties window appears; navigate the tabs as necessary.
5. Navigate to the **Triggers** tab, to ensure the task is enabled.

## 5.2 Input Files

There are four types of input files used by the profiling radiometer:

- 1 Configuration File
- 1 or more Procedure Files
- Macro Files (optional)
- Neural Network Files (optional)

These files are used by the Operating Code to configure the system, schedule observations, and convert raw data to higher level products. Through these files, the user specifies all the programmable features and options available in profiling radiometer.

### 5.2.1 Configuration File

The configuration file contains all the static parameters needed to specify how the profiling radiometer will operate, and the calibration information necessary to convert level0 data to level1 observations. Figure 5-3 illustrates a typical configuration file<sup>26</sup>. The configuration file may be edited in **Notepad** (or another text editor) to change the configuration. Care should be exercised not to inadvertently change any parameter

<sup>26</sup> The details of the configuration file format are operating code version dependent. Earlier and later versions of the operating code may differ slightly in the list of configuration parameters and the format.

unintentionally. In particular, care should be taken to save changes to the file in plain text format only (no formatting).

The configuration information is grouped in logical blocks with block headers for each highlighted in red in this manual. Generally, parameters are specified in the first field of each line, with comments following a colon delimiter. The use of each field is explained below.

In the MP TYPE block, the specific model and serial number are specified. These fields are specified by the factory and used by the Operating Code to determine what features are enabled for the specific instrument. The Serial Number specified appears in the real-time displays to distinguish different instruments under the control of one computer. The COM port used by the controlling computer is specified on the next line. The COM port specified must be in the range 1-9, and correspond to the Windows COM port connected to the profiling radiometer. Setting the “debug” parameter to 1 will enable a serial data link traffic log. The log is stored in the operating folder with a file name in this format:

yyyy-mm-dd\_hh-mm-ss\_ser.txt.

```

# Radiometrics v6.00 configuration file for 3105A
# Configuration File Format: 6.00
# No more comments

MP TYPE:
MP-3000A 3105A :Model & Serial Number
4 :Windows com port (1 to 9)
1 :debug (1=on; 0=off)
1 :PC clock sync to GPS (1=on; 0=off)

TIP CONFIGURATION: (For all TIP Commands)
0.98 :regression coeff for a good tip
0.0 :Default Azimuth Angle
5 :Number of Elevation Angles
30 :Tip Elevation Angle #1
45 :Tip Elevation Angle #2
90 :Tip Elevation Angle #3
135 :Tip Elevation Angle #4
150 :Tip Elevation Angle #5
0 :No tips when rain sensor on, 1=allow tips w/rain on
0.8 :rain sensor tip threshold (volts)

BLOWER SETTINGS:
0.80 :rain sensor blower threshold (volts)
70 :RH threshold (%)
30 :Blower speed (rain and RH both below threshold)

SYNTHESIZER TYPE:
4 :1 = Microsource 11.0-15.0 GHz; 2 = 11.0-15.3 GHz; 4 = Spinnaker Microwave 11.0-15.0 GHz

CHANNEL CALIBRATION BLOCK:
2012/01/17 19:59:11 Date of last factory LN2 calibration
2012/01/18 18:11:59 Date of last user LN2 calibration 2012-01-18_16-43-10_lv0
10,10.0,2.5,1,200 :ln2 calibration integration parameters
.90 :target tolerance for ln2 cal
35 :number of frequencies

Frequency, Rcvr, MWT, window, Coef, ND, drive, IF, Atten, alpha, dtdg, k1, k2, k3, k4, Tnd
22.000,0.275,0.0,000140, 32860,18.5,0.98641, -0.61873428E+06, 0.16552952E+03, -0.14797976E+01, 0.44810639E-02, -0.46433101E-05, 389.19
22.234,0.275,0.0,000140, 30665,18.5,0.98531, -0.56325850E+06, 0.27947977E+03, -0.24487038E+01, 0.72539921E-02, -0.73564476E-05, 321.23
22.500,0.275,0.0,000140, 30665,18.5,0.98326, -0.45119162E+06, 0.47044898E+03, -0.47731193E+01, 0.16079795E-01, -0.17981678E-04, 305.58
23.000,0.275,7.0,000150, 30665,19.0,0.98611, -0.42160549E+06, 0.35827655E+03, -0.36831119E+01, 0.12603610E-01, -0.14356378E-04, 288.79
23.034,0.275,7.0,000150, 30665,19.0,0.98594, -0.42164813E+06, 0.33439000E+03, -0.34484621E+01, 0.11817757E-01, -0.13457270E-04, 290.11
23.500,0.275,7.0,000150, 30665,19.0,0.98775, -0.45578882E+06, 0.21934848E+03, -0.20312081E+01, 0.62844035E-02, -0.65118070E-05, 314.58
23.834,0.276,0.0,000150, 28470,18.5,0.98937, -0.41244588E+06, 0.26852572E+03, -0.25622278E+01, 0.81516131E-02, -0.86526846E-05, 287.46
24.000,0.275,7.0,000150, 28470,18.5,0.99049, -0.43345979E+06, 0.33379880E+03, -0.33841307E+01, 0.11450928E-01, -0.12933041E-04, 298.23
24.500,0.275,7.0,000160, 28470,18.5,0.99362, -0.48431930E+06, 0.23642837E+03, -0.22860500E+01, 0.74224842E-02, -0.81063097E-05, 311.99
25.000,0.275,4.0,000160, 28470,18.5,0.99150, -0.51282767E+06, 0.51247359E+03, -0.50765294E+01, 0.16814566E-01, -0.18630738E-04, 330.36
25.500,0.275,4.0,000160, 28470,18.5,0.99097, -0.48230281E+06, 0.51240946E+03, -0.52089970E+01, 0.17636046E-01, -0.19885678E-04, 311.26
26.000,0.275,4.0,000170, 28470,18.0,0.98790, -0.50977331E+06, 0.38361635E+03, -0.38073944E+01, 0.12668623E-01, -0.14141751E-04, 319.98
26.234,0.275,4.0,000170, 30665,18.0,0.98694, -0.47111980E+06, 0.37591316E+03, -0.36085561E+01, 0.11586251E-01, -0.12457895E-04, 361.69
26.500,0.275,4.0,000170, 30665,18.0,0.98462, -0.51386321E+06, 0.63749879E+03, -0.63501749E+01, 0.21166339E-01, -0.23618729E-04, 357.49
27.000,0.275,4.0,000170, 30665,18.5,0.98337, -0.52496762E+06, 0.37188566E+03, -0.36941876E+01, 0.12304234E-01, -0.13750352E-04, 355.01
27.500,0.275,4.0,000180, 30665,19.0,0.98900, -0.48532285E+06, 0.39869196E+03, -0.38372004E+01, 0.12358856E-01, -0.13337309E-04, 330.61
28.000,0.275,4.0,000180, 30665,19.0,0.99217, -0.48594097E+06, 0.56892564E+03, -0.57138144E+01, 0.19200887E-01, -0.21596378E-04, 325.09
28.500,0.274,1.0,000180, 30665,19.5,0.99647, -0.49609549E+06, 0.34558652E+03, -0.34256708E+01, 0.11288210E-01, -0.12361329E-04, 304.63
29.000,0.274,1.0,000180, 30665,19.5,0.99523, -0.51678051E+06, 0.56743425E+03, -0.56479265E+01, 0.18739557E-01, -0.20727881E-04, 320.87
29.500,0.274,1.0,000190, 30665,19.5,0.98442, -0.48540158E+06, 0.33834682E+03, -0.34135868E+01, 0.11491872E-01, -0.12910455E-04, 314.67
30.000,0.274,1.0,000190, 32860,20.0,0.97897, -0.44205776E+06, 0.28239717E+03, -0.27492248E+01, 0.89561186E-02, -0.97720922E-05, 315.31
51.248,1.274,1.0,000330, 32860,18.5,0.97277, -0.91285866E+06, 0.24253657E+03, -0.24829452E+01, 0.84490822E-02, -0.9555488E-05, 325.09
51.760,1.274,1.0,000330, 32860,18.5,0.97222, -0.80608886E+06, 0.24580693E+03, -0.24140922E+01, 0.78224070E-02, -0.83473953E-05, 318.88
52.280,1.274,1.0,000330, 32860,18.0,0.97269, -0.74182710E+06, 0.33630927E+03, -0.34073425E+01, 0.11482145E-01, -0.12867618E-04, 336.33
52.804,1.274,1.0,000340, 32860,17.5,0.97998, -0.83931714E+06, 0.16935851E+03, -0.16117526E+01, 0.49737834E-02, -0.49303145E-05, 343.82
53.336,1.274,1.0,000340, 32860,17.0,0.99046, -0.10195484E+07, 0.50704810E+03, -0.50895713E+01, 0.16995735E-01, -0.18877926E-04, 366.39
53.848,1.274,1.0,000340, 32860,16.5,0.99299, -0.90029195E+06, 0.62334826E+02, -0.58612085E+00, 0.17116899E-02, -0.14897249E-05, 343.67
54.400,1.274,1.0,000350, 32860,16.0,0.99094, -0.87296572E+06, 0.39422046E+03, -0.38945312E+01, 0.12855721E-01, -0.14185598E-04, 339.36
54.940,1.274,1.0,000350, 32860,16.0,0.98792, -0.87669780E+06, 0.32552637E+03, -0.33548683E+01, 0.11407874E-01, -0.12793340E-04, 343.95
55.500,1.274,1.0,000350, 32860,16.5,0.98167, -0.83458820E+06, 0.23725238E+03, -0.23048125E+01, 0.74176202E-02, -0.7900259E-05, 315.34
56.020,1.274,1.0,000360, 32860,16.5,0.97627, -0.85216924E+06, 0.30444887E+03, -0.31682616E+01, 0.10860035E-01, -0.12258885E-04, 335.52
56.660,1.274,1.0,000360, 32860,16.5,0.98066, -0.86550481E+06, 0.11883351E+03, -0.11233224E+01, 0.34236137E-02, -0.33210022E-05, 313.82
57.288,1.274,1.0,000370, 32860,16.0,0.99553, -0.97899503E+06, 0.39717539E+03, -0.39532900E+01, 0.13114886E-01, -0.14501751E-04, 306.85
57.964,1.274,1.0,000370, 32860,15.0,0.99553, -0.89466971E+06, 0.23724946E+03, -0.23983795E+01, 0.80350724E-02, -0.89166837E-05, 274.61
58.800,1.274,1.0,000370, 32860,14.0,0.98123, -0.76838684E+06, 0.32696305E+03, -0.33196721E+01, 0.11134266E-01, -0.12327275E-04, 246.90

COEFF:
13.0 :LN2 lig depth in cm
68.23 :LN2 BP C0, the LN2 boiling point linear equation
0.009037 :LN2 BP C1
0.0078 :LN2 interfaces correction
6.08e-6 :LN2 polystyrene dielectric loss coef ~ 1.16e-5 K/k-cm-GHz
5.1 :LN2 styrofoam thickness [cm]
+600.00,200.00 :Air press C0,C1 (P=C0+C1*volts)
+0.16,4.135 :East/west tilt offset C0, X-Axis scale factor C1.
+0.77,4.132 :North/south tilt offset C0, Y-Axis scale factor C1.
.050,.065 :IRT window reflection, absorption

USER CORRECTIONS:
+0.00 :Pressure sensor offset
+0.00 :Tamb correction (edit with values for this instrument)
+0.00 :Rh correction (edit with values for this instrument)
+0.00 :BB sensor correction (default=-1.50)

GPS:
15 :Cut-off elevation angle
0 :Minimum SNR

```

Figure 5-3. Configuration file (mp.cfg) for v6.x.x operating code

## GPS Time Sync: 0 = off, 1 = on

If **on**, control computer clock synchronizes to GPS time, when the instrument starts or restarts, provided the MS Windows™ clock is 5 minutes or less from GPS time. Set the MS Windows™ clock to within  $\pm 5$  minutes to ensure synchronization.

The TIP configuration block specifies all parameters used by the TIP calibration algorithm. The regression coefficient is a threshold for data quality checks. It should be adjusted to a value between 0.97 and 0.99 normally. Higher thresholds impose a higher quality standard. The default Azimuth Angle specifies the azimuth for TIP calibrations when the optional Azimuth Positioner is installed. The next line specifies the number of elevation angles the instrument will use for the TIP calibration. This number must match the number of lines below, each specifying a specific elevation angle. In general, it is recommended that the 5 default values specified in the example be used. TIP elevation angles less than 20° may result in some side lobe contamination. More angles can be used, but the extra time required must be considered. Longer times to complete the TIP can introduce sampling error as the atmosphere changes. In all cases, it is desirable (but not required) to specify TIP angles in complementary pairs (e.g., 045° and 135°, 030° and 150°) so that leveling error and atmospheric gradients tend to be averaged. Following the last angle, a switch is provided to either allow, or not allow TIPs when the rain sensor detects rain. The last line in the block specifies the threshold defining when the rain sensor flag is switched as described in **Appendix E**.

In the Superblower Settings block, the user can specify the conditions for the Superblower flow rate to be reduced from its maximum rate. The Superblower flow will be automatically set to the maximum rate (100%) if the rain sensor voltage exceeds the specified threshold (.8V typical), or the surface RH exceeds the specified threshold (70% typical). If neither condition is met, then the Superblower flow will be set to the specified low blower speed value (30% typical). To turn off the Superblower, set both thresholds very high (e.g., 2V and 101%) and the low blower speed to 0. To force it on all the time, set the rain or RH threshold to 0. Note that the Superblower is always set to 100% while an LN2 user calibration is running, to slow moisture condensation on the cryogenic target.

The Synthesizer Type is set at the factory and should not be changed.

The CHANNEL CALIBRATION BLOCK contains all the factory and user LN2 calibration data. This block is set up at the factory and should not be edited by the user, except to manually transfer a new TIP calibration as discussed in **Appendix E**.

The COEF block contains all the parameters needed by the Operating Code to compute the effective cryogenic target temperature, and for the conversion of level0 Met Sensor data to level1. These values are set at the factory and, except for LN2 depth, should not normally need to be adjusted by the user.

The User Corrections block can be used to *add* an offset adjustment to the ambient pressure, temperature and RH. The factory calibrations for these three sensors are very accurate and do not normally require further adjustment. In general, no offset value should be added unless the user has access to high accuracy standards for calibration of these three sensors.

The GPS block is reserved for future use.

## 5.2.2 Procedure Files

A Procedure File is a list of high level commands that define a specific series of observations and retrievals to be performed. Two basic types of procedures can be defined: “relative” and “absolute”. Relative procedures are command lists that execute sequentially, with each command beginning immediately following the completion of the previous command. Absolute procedures are command lists in which each command is specified to execute at a specific time of day. Procedure files provide the user with a simple, but powerful way to customize the operation of the instrument for automatic data collection. All Procedure Files are ASCII text files with the extension “.prc” (e.g., ZenithRet.prc). Procedure files can be generated using any text editor, such as Notepad. However, long absolute procedures with many repeating commands are more easily generated using a spreadsheet to automatically compute the series of **absolute** command execution times.

### 5.2.2.1 Procedure Commands

Procedure Commands are the basic building blocks used to create a procedure. There are 10 high-level commands available. Each command occupies one line in a Procedure File, starting in the first column of the line, and terminated by a carriage return (**CR**). Commands with required or optional parameters are delimited by one or more spaces, or one tab or one comma character may be used between fields in command lines.

**NOTE:**

All procedure commands must be specified in lower-case letters **only**.

#### *5.2.2.1.1 Antenna Coordinate System*

The coordinate system used in all commands to specify the antenna-pointing vector is given in Table 5-3. The elevation angle is defined for the state when  $az=000^\circ$  (north). Therefore, if the azimuth is rotated to  $180^\circ$  (south), the antenna will point to the southern horizon when  $el=000^\circ$ .

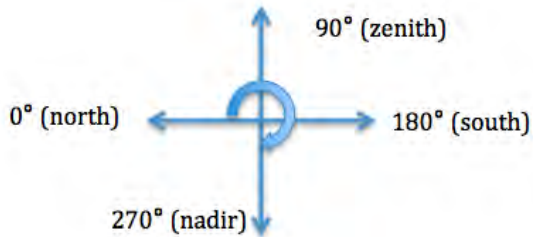
| Azimuth (az)   |       | Elevation (for az=000)   |        |
|--|-------|--|--------|
| 000°   | north | 000°   | north  |
| 090°   | east  | 090°   | zenith |
| 180°   | south | 180°   | south  |
| 270°   | west  | 270°   | nadir  |
| Mirror orientation for Azimuth = 000, as viewed when standing behind the radiometer. |       |  |        |

**Table 5-3. Antenna coordinate system**

**NOTE:**

There are always two az/el specifications that produce the same pointing direction. For example, the direction given by az=000°/el=045° is equivalent to the direction az=180°/el=135°. The Operating Code automatically chooses the coordinates that will reposition the antenna faster, regardless of which way the user specifies the coordinates.

**NOTE:**

The elevation drive resolution is 0.45° (800 steps per revolution). If an angle is specified that is not an even multiple of 0.45°, then the Operating Code rounds the number to the nearest angle available, and the angle actually used is logged in the output files. For example, if the user specifies an elevation angle of 30.00°, the radiometer will use and record 30.15°.

**5.2.2.1.2 relative, absolute and repeat Commands**

The first line in all Procedure Files must contain either the “**relative**” or “**absolute**” command. These commands define whether all the commands that follow are to be executed sequentially, with no delay between commands, or executed at a specified time. With both relative and absolute procedures, the command sequence specified will continue to execute until the operator presses the Control Computer **Q** key to Quit, or the end of the procedure is reached, whichever occurs first. If the command “**repeat xxxxx**” is added as the last command in a relative procedure, then the complete procedure will be repeated xxxxx times before the program terminates, where xxxxx is any positive integer. **Relative**, **absolute** and **repeat** commands do not add to the execution time of the procedure.

### 5.2.2.1.3 The **trcvcal** Command

The **trcvcal** command causes the profiling radiometer to calibrate the receiver noise temperature for all microwave receivers present. This calibration produces a new value of system temperature for all specified channels, from which a new value of receiver temperature (Trcv-bb) is calculated ( $\text{Trcv-bb} = \text{Tsys} - \text{TkBB}$ ) for all specified channels. This value of Trcv-bb is used in the calculation of all real-time level1 and level2 data products.

The receiver temperature is very stable over a period of minutes, but will drift slightly with large ambient temperature changes. Thus, **trcvcal** commands should be included periodically in all procedures.

In choosing a **trcvcal** command frequency, several factors should be considered. Very frequent **trcvcal** commands will result in the best theoretical absolute accuracy. However, **trcvcal** commands take approximately the same execution time as the **obs** commands. Thus, a **trcvcal** command preceding every sky observation may produce the smallest drift error, but it reduces the available sky observation time. Practical experience suggests one **trcvcal** command every 5 minutes, with many **obs** commands in between, is adequate in nearly all cases.

The command format for the **trcvcal** command is:

**hh:mm:ss trcvcal nsec,nint,n0,n1,f01,...,f0n0,f11,f12,...f1n1**

...where:

**nsec** is reserved for future use (set to 0)

**nint** is the integration time in milliseconds

**n0** is the number of RCV0 frequencies to calibrate

**n1** is the number of RCV1 frequencies to calibrate

**fij** is jth frequency in MHz for ith receiver. Must be in order by receiver and frequency.

### 5.2.2.1.4 The **cal21** Command

The **cal21** command is applicable to the MP-3000A and MP-1500A only. It causes the profiling radiometer to collect a set of 22-30 GHz observations at elevation angles specified in the configuration file. From these observations, estimates of the Noise Diode temperatures (Tnd) for all 21 K band channels are derived. These estimates of Tnd are logged to the current yyyy-mm-dd\_hh-mm-ss\_tip.csv file for calibration use as described in **Appendix E** on radiometer calibrations (page E-15).Section.

The command format for the **cal21** command is:

**hh:mm:ss cal21 az int-time**

...where the value **az** = azimuth angle to be used for the **cal21** observations (if the optional Azimuth Positioner is installed), and **int-time** is the integration time in

milliseconds for one channel (200 msec typical). Since the TIP Calibration process uses the latest available surface met data and Trcvcal data as input, it is best to precede all **cal21** commands with a **met** command and trcvcal command within the previous 1-2 minutes.

#### 5.2.2.1.5 The **obs** Command

The **obs** command directs the profiling radiometer to point the antenna to a specific elevation angle (el), and if the optional Azimuth Positioner is installed, to a specific azimuth angle (az), and then measure the brightness temperature on all specified channels for the specified integration times. If no Azimuth Positioner is installed, a dummy value of az = 000 should be included in the command. The command format for the **obs** command is:

**hh:mm:ss obs az,el,nint,n0,n1,f01,....,f0n0,f11,f12,...f1n1**

...where:

**az** is the observation azimuth  
**el** is the observation elevation  
**nint** is the integration time in milliseconds  
**n0** is the number of calibrated RCV0 frequencies to observe  
**n1** is the number of calibrated RCV1 frequencies to observe  
**fij** is **jth** frequency in MHz for **ith** receiver. Must be in order by receiver and frequency.

#### 5.2.2.1.6 The **met** Command

The **met** command logs the current surface met sensor data (Tamb, RH, Pressure, IRT temperature (if the optional IRT is installed) and Rain. There are no parameters. The command format is:

**hh:mm:ss met**

#### 5.2.2.1.7 The **eng** Command

The **eng** command logs the current values of 48 housekeeping data parameters (also known as engineering data) in the level0 file, record type 91. There are no command line parameters. The values logged are as follows:



| MCM & Frame Readings |                               | Receiver 0 Readings |                               |
|----------------------|-------------------------------|---------------------|-------------------------------|
| Index                | Description                   | Index               | Description                   |
| 0                    | V0 / Rain voltage             | 26                  | RCV0 TECV                     |
| 1                    | V1                            | 27                  | RCV0 TEC Duty Cycle           |
| 2                    | V2                            | 28                  | RCV0 Antenna Temperature (T1) |
| 3                    | TEMP0 / BB0                   | 29                  | RCV0 TkND (T2)                |
| 4                    | TEMP1 / BB1                   | 30                  | RCV0 TkIF (T3)                |
| 5                    | TEMP2 / Cabinet               | 31                  | RCV0 Case Temperature (T4)    |
| 6                    | TEMP3 / IRT0 - Reflected (BB) | 32                  | RCV0 +8V                      |
| 7                    | TEMP4 / IRT1 - Transmitted    | 33                  | RCV0 ND On Voltage            |
| 8                    | TEMP5 / Spare                 | 34                  | RCV0 ND Off Voltage           |
| 9                    | TEMP6 / Spare                 |                     |                               |
| 10                   | TEMP7 / Spare                 |                     |                               |
|                      |                               | Receiver 1 Readings |                               |
| 11                   | Vdist MCM                     | Index               | Description                   |
| 12                   | +12VD MCM                     | 35                  | RCV1 TECV                     |
| 13                   | +8VD MCM                      | 36                  | RCV1 TEC Duty Cycle           |
| 14                   | +5VD MCM                      | 37                  | RCV1 Antenna Temperature (T1) |
| 15                   | +3.3VD MCM                    | 38                  | RCV1 TkND (T2)                |
| 16                   | +2.5VD MCM                    | 39                  | RCV1 TkIF (T3)                |
| 17                   | -5VD MCM                      | 40                  | RCV1 Case Temperature (T4)    |
| 18                   | 2.5VR MCM                     | 41                  | RCV1 +8V                      |
| 19                   | Pressure Sensor Temp          | 42                  | RCV1 ND On Voltage            |
| 20                   | Pressure Sensor Output        | 43                  | RCV1 ND Off Voltage           |
| 21                   | Pressure Sensor Reference     |                     |                               |
| 22                   | Computed Pressure             |                     |                               |
|                      |                               | Elevation Readings  |                               |
| 23                   | S3 Temp                       | Index               | Description                   |
| 24                   | S3 Humidity                   | 44                  | Home Offset                   |
| 25                   | IRT Temp                      | 45                  | East / West Tilt              |
|                      |                               | 46                  | North / South Tilt            |
|                      |                               |                     |                               |
|                      |                               | Other               |                               |
|                      |                               | Index               | Description                   |
|                      |                               | 47                  | SuperBlower Speed             |

**Table 5-4. Housekeeping data parameters logged by “eng command”**

#### 5.2.2.1.8 The **tdp** Command

The **tdp** command logs the current GPS time, date and position in the level0 file, record type 31. Additional data about the current status of the GPS is also included in the type 31 record. The command format is:

**hh:mm:ss tdp**

There are no command line parameters for the **tdp** command.

### 5.2.2.1.9 The **mac** Command

**mac** commands function like subroutines in software codes. They provide the means to create time saving custom user commands consisting of any valid series of standard commands often repeated. Commands within a macro file do not require a time at the beginning of the command line. They are executed like a relative procedure, with no delay between the commands. Valid commands for inclusion in a macro file include all except the **mac** and **repeat** commands. **mac** commands cannot be “nested”. The format is:

**hh:mm:ss mac macro**

...where **macro** is the file name of a macro stored in the macro subdirectory, located in the operating folder.

As an example, suppose a user needs to routinely repeat a sequence of observations at 6 azimuth angles evenly spaced 60 degrees, at an elevation angle of 30 degrees, on 2 K band and 2 V band frequencies. The macro file contents might look like this:

```

trcvcal    0,200,2,2,23834,30000,51248,58800
obs       0.0,30.0,200,2,2,23834,30000,51248,58800
obs       0.0,150.0,200,2,2,23834,30000,51248,58800
obs       60.0,30.0,200,2,2,23834,30000,51248,58800
obs       60.0,150.0,200,2,2,23834,30000,51248,58800
obs       120.0,30.0,200,2,2,23834,30000,51248,58800
obs       120.0,150.0,200,2,2,23834,30000,51248,58800

```

Now suppose the macro file is given the name “**mac1**” and the file is stored in the macro subdirectory. With this macro stored, procedures can use the following command to execute all 7 commands listed in the macro:

**hh:mm:ss mac mac1**

When executed, the **mac1** command will calibrate the receiver temperature on 4 frequencies (22000, 23834, 51248 and 58800 MHz) using 200 msec integration time, then point the antenna to az=0.0; el=30.0 degrees and collect brightness temperatures on the same 4 frequencies using 200 msec integration time, then repeat the observations at the next 5 az/el pointing angles. Because azimuth moves are relatively slow (15 degrees/sec) compared to elevation moves (180 degrees/sec), this macro uses 3 azimuth angles (0, 60 and 120 degrees) and alternating elevation angles (30 and 150 degrees) to save time.

### 5.2.2.1.10 The **nnret** Command

The **nnret** command produces neural network derived level2 data from current level1 data. For the MP-3000A, 5 neural network retrievals are typically provided for each site where the instrument will be used. These include retrievals for profiles of temperature,

RH, vapor and liquid plus scalar values of integrated vapor and integrated liquid. The command format is:

**hh:mm:ss nnret nnfilename,1or0<sup>27</sup>**

...where **nnfilename** is the name of a neural net file located in the operating folder, and **1** or **0** enables/disables surface met substitution into profiles for temperature, vapor, and Rh with nnret flag.

### 5.2.2.2 Relative Procedures

In general, use relative procedures when the fastest possible observation cycle time is required, and control over the exact time of the observations is less important. Relative procedures generally execute more quickly than absolute procedures because there is no wait-state time between commands. To specify that a procedure is a relative procedure, enter the word “**relative**” in the first line of the procedure, and hit the **Enter** key to insert a carriage return (**CR**). Subsequent commands in a relative procedure each have dummy time fields with all zeros (00:00:00) followed by the command and parameters, if any.

Relative procedures are also useful to determine the execution times for each of the commands in a sequence of commands that the user desires to execute in an absolute file. The execution time of some commands depends on many variables, some of which cannot be easily predicted. For example, antenna movements from one position to another require different times depending on the specific start and ending angles. Thus, it is not practical to provide exact command sequence execution times for all commands in all cases. However, any user-defined sequence of commands can be timed using a relative procedure. Once the command execution times are known for a given sequence of commands, an absolute procedure can be written to provide sufficient time for the execution of each command, without wasting unnecessary wait-state time between commands.

### 5.2.2.3 Absolute Procedures

Absolute procedures provide uniform observation and calibration timing in the output files, best suited for most operational scenarios. Unlike relative procedures, each command in an absolute procedure is executed at a specific hour, minute and second, specified in the first field of the command (hh:mm:ss). To specify that a procedure is an absolute procedure, enter the word “**absolute**” in the first line of the procedure, and hit the **Enter** key to insert a carriage return (**CR**). Subsequent commands in an absolute procedure each have execution times followed by the command and parameters, if any. The execution times must be sequential, and the time of execution for all commands must be specified to provide sufficient time for the previous command to complete.

---

<sup>27</sup> This enable/disable function begins with code version mp\_v6.11.exe, on radiometers with serial number 3116 and later, or after September 2012. **nnretfilename** and **nnretfilename,0** both disable the substitution.

Commands specified to execute before the completion of the previous command will be skipped.

Absolute procedures can also be programmed to provide different observation and calibration sequences at different times of the day. For example, a procedure could be written to collect only zenith observations during the day, and TIP calibrations during the night. Or, each hour of the day could be divided into two periods: one set of observations for the first 50 minutes, and different observations for the other 10 minutes of the hour. In this way, the user has complete control over the observation sequence and timing.

#### **5.2.2.4 Procedure Timing**

As noted above, command execution times vary, depending on integration time, the previous state of the antenna position, and other factors. To ensure that all commands complete before the next is scheduled to execute, a new command sequence can be timed by using a relative procedure. Typical execution times can be determined by examining the level0 file produced by a relative procedure, noting the times of each command execution. For example, if a given configuration and command sequence results in the **obs** command taking 13-14 seconds, the user might allocate 15 seconds for that command to provide some timing margin.

#### **5.2.2.5 Choosing the Integration Time**

Longer integration times result in longer command execution times. Thus, for the maximum observation frequency, shorter integration times are desirable. However, shorter integration times result in a higher contribution of random noise resulting from the thermal noise inherent in all radiometers. Figure 5-4 illustrates the impact of integration time on the thermal noise component ( $\Delta T_n$ ) of the total random noise.

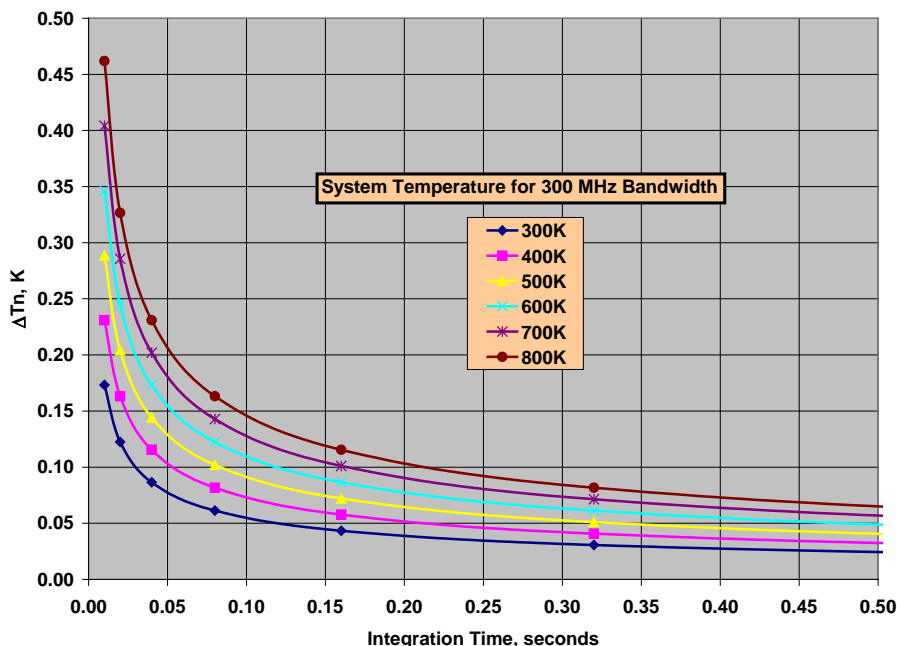

**Figure 5-4. Theoretical thermal noise for radiometers**

For most applications, an integration time of ~200 msec is optimum for the profiling radiometers. Below 50 msec,  $\Delta T_n$  increases rapidly, and due to constant command overhead times, such as for antenna positioning between commands, further reduction of the integration time does little to reduce the command execution time. On the other hand,  $\Delta T_n$  reaches such a small value above 500 msec that other sources of noise (e.g., atmospheric and residual  $1/f$ ) become dominant. Thus, there is normally very little benefit resulting from longer integrations.

### 5.2.3 Factory Procedure Files

The following standard procedure files are provided (xxx is a site-dependent 3-letter code):

| Filename             | Description  |
|----------------------|--|
| <b>B&amp;I35.prc</b> | Performs alternating observations of the internal ambient target and an external cryogenic target; used mainly for diagnostic use. |
| <b>Tip21.prc</b>     | Performs continuous 21-channel TIP calibrations (MP-1500A and 3000A only)  |
| <b>Zen_35_tb.prc</b> | Performs continuous zenith observations of all 35 brightness temperatures (MP3000A only).  |

|                                 |   |
|---------------------------------|---|
| <b>xxx_zen_ret.prc</b>          | Performs continuous zenith retrievals of temperature, vapor density, liquid density, relative humidity profiles (MP1-500A produces only vapor density profiles) and integrated vapor and liquid scalar values based on 22 zenith brightness temperatures and 4 surface met observations. (For MP-1500A, 14 zenith brightness temperatures and 3 surface met). |
| <b>xxx_zen_ret_tip.prc</b>      | Same as above with added 21-channel TIP calibration.  |
| <b>xxx_zen35_ret_scan4f.prc</b> | Performs continuous 35 channel zenith brightness temperature observations, retrievals from the observations as in xxx_zen_ret.prc and an azimuth scan (6 angles) of 4 frequencies at 30 degrees elevation brightness temperatures.  |
| <b>xxx_oz_15.prc</b>            | Same as xxx_zen_ret.prc except additional observations are collect at “off-zenith angles” (14.85° and 165.85°) and used for additional retrievals of temperature, vapor density, liquid density, and relative humidity profiles (north, south and average)  |
| <b>xxx_oz_15_tip.prc</b>        | Same as above with added 21-channel TIP calibration.  |

**Table 5-5. Standard procedure files**

### 5.2.4 Neural Network Files

Use neural networks to retrieve atmospheric temperature, humidity and liquid profiles from profiling radiometer level1 measurements. The neural networks are trained using data from historical radiosonde soundings. Several years of radiosonde data from one or more sites in the same climatological region as the observation site are typically used for neural network training. The radiosonde soundings are forward modeled using atmospheric emission models and radiative transfer equations to provide brightness temperatures that would have been observed at ground level. The neural networks find the temperature, humidity and liquid profile (atmospheric state) retrievals that best correlate with the radiometric observations. There is a separate neural network file for GPS observations. The neural network files are trained using the Stuttgart Neural Network Simulator and a standard back propagation method.

New profiling radiometers are delivered with one set of neural network files included. The user must specify the region of operation, or radiosonde site to be used for training. Additional neural network files may be purchased for other sites. Contact Radiometrics Sales and Marketing for further information.

To change neural network files used for real-time level2 processing, simply add the new neural network files to the operating folder and specify these files in the procedure file **nnret** commands used for retrievals.

**NOTE:**

Operation of the radiometer with neural network files trained for a different site may produce profiles with significant error. However, the level0 and level1 data will not be affected. If the radiometer is operated with incorrect neural network files, the level1 data can be reprocessed with the correct neural network files at a later time.

### 5.3 Output Files

There are 5 standard output files generated by the Operating Code. Common conventions used in all the files are described below, followed by descriptions of each output file type.

#### 5.3.1 Output File Name Conventions

All output files use the .csv extension to indicate to other application programs that the files conform to the industry standard comma separated variable data base format. Most mathematical analysis, spreadsheet and database programs can open and manipulate the data in these files with little or no reformatting. All output files are named automatically using the following format:

**yyyy-mm-dd\_hh-mm-ss\_xxx.csv**

...where

**yyyy** is the year when the file was started

**mm** is the month of the year

**dd** is the day of the month

**hh** is the hour of the day

**mm** is the minute of the hour

**ss** is the second of the minute

...and **xxx** defines the output file type as follows:

**xxx=lv0** level0 file

**xxx=lv1** level1 file

**xxx=lv2** level2 file

**xxx=tip** TIP calibration file

**xxx=ln2** LN2 calibration file

**xxx=ser** com port log

This file naming convention orders the files chronologically when sorted alphabetically by name.

### 5.3.2 Record Number

All output files contain a sequential record number in the first field, starting with the number 1. If a file has been sorted analyze by record type, elevation angle, or any other parameter in the file, use the record number field to restore the file to its original order.

### 5.3.3 Date/Time Conventions

All output files contain a date/time stamp in the second field of all records that contain time dependent data. All output files use the following date/time stamp convention for each record in the file:

**mm/dd/yyyy hh:mm:ss**

...where

**mm** is the month  
**dd** is the day  
**yyyy** is the year  
**hh** is the hour  
**mm** is the minute  
**ss** is the second

The time corresponds to the time of the completion (end) of the observation set.

#### **NOTE:**

If a file is opened in Excel or similar application, the date/time stamp can be reformatted easily to any other standard format and saved in that revised format.

### 5.3.4 Record Type Conventions

All output files contain a record type number in the third field of all records. The record type number defines the header or data type in that record. Record types for each file type are grouped in blocks and numbered sequentially beginning with the number assigned to the header for that block. Record headers define all the fields in each block.

Data is logged sequentially in the order of the observations. For some types of analysis, it is more convenient to sort the data based on different parameters. Sorting a file by record type is often a useful first step to analysis. When a file is sorted by record type (third column in a spreadsheet, for example), the data automatically sorts into logical blocks with the appropriate header for each block appearing at the top of each block. Second level criteria can be used to sort the data within each block by elevation or azimuth angle, ambient temperature, or any other field appearing in the record.

### 5.3.5 Level0 File

Level0 files contain raw, unprocessed data in engineering units. A level0 file is produced for all modes of operation and all options that can be selected from the main menu.



Level0 files contain 100% of the information needed to reprocess the raw data with alternative calibration information or algorithms. Level0 files contain the following record types:

| <b>Record type</b> | <b>Description of Record Type</b>                             |
|--------------------|---|
| <b>00</b>          | <b>Record type for all error reports</b>                      |
| <b>15</b>          | <b>Header for sky observations</b>                            |
| <b>16</b>          | <b>obs command sky observation</b>                            |
| <b>17</b>          | <b>cal21 command sky observation</b>                          |
| <b>25</b>          | <b>Header for observation of internal ambient black body</b>  |
| <b>26</b>          | <b>BB observation for trcvcal command</b>                     |
| <b>30</b>          | <b>Header for tdp command (GPS) records</b>                   |
| <b>31</b>          | <b>GPS time/date/position data</b>                            |
| <b>40</b>          | <b>Header for surface met records</b>                         |
| <b>41</b>          | <b>Tamb, RH, pressure, Tir and rain sensor</b>                |
| <b>60</b>          | <b>Header for LN2 calibrations</b>                            |
| <b>61</b>          | <b>Record of LN2 cal data (includes BB, LN2 observations)</b> |
| <b>90</b>          | <b>Header for housekeeping data (eng command)</b>             |
| <b>91</b>          | <b>eng command data</b>                                       |
| <b>99</b>          | <b>Record type for echo of mp.cfg file to level zero file</b> |

**Table 5-6. Level0 record types**

### 5.3.6 Level1 File

Level1 files contain real-time brightness temperatures for each channel specified in the configuration file. Real-time level1 files are produced from contemporaneous level0 data and calibration information in the configuration file. Level1 files contain the following record types:

| Record type | Description of Record Type              |
|-------------|---|
| 40          | Header for surface met records          |
| 41          | Surface met data record                 |
| 50          | Header for sky observations             |
| 51          | obs command sky observation data record |

Table 5-7. Level1 record types

### 5.3.7 Level2 File

Level2 files contain records of real-time retrievals of temperature (K), water vapor ( $\text{g/m}^3$ ), relative humidity (%) and liquid water ( $\text{g/m}^3$ ) profiles. The retrievals are produced using the contemporaneous level1 data and the neural network files specified in the configuration file. Level2 files contain the following record types:

| Record type | Description of Record Type                               |
|-------------|--|
| 100         | Header for vector retrieval index                        |
| 101         | Vector retrieval index entry                             |
| 200         | Header for surface met records                           |
| 201         | Tamb, RH, pressure, Tir and rain sensor                  |
| 300         | Header for scalar retrieval records                      |
| 301         | Scalar retrieval data record                             |
| 400         | Header for vector retrieval records (58 heights)         |
| 401         | Temperature vector retrieval data record (profile)       |
| 402         | Vapor Density vector retrieval data record (profile)     |
| 403         | Liquid Density vector retrieval data record (profile)    |
| 404         | Relative Humidity vector retrieval data record (profile) |

Table 5-8. Level2 record types

### 5.3.8 TIP Calibration File

TIP files contain the results of successful TIP calibration attempts. For each **cal21** command in a Procedure File, the level0 data is processed in real-time by the TIP calibration algorithm. For each TIP frequency specified in the configuration file, atmospheric opacity is computed for each elevation angle. The TIP calibration algorithm attempts to fit all the opacity values for each frequency to a linear function of air mass (number of equivalent atmospheres for a given elevation angle). If the linear regression for all channels is better than the regression threshold “r” specified in the configuration file, then the TIP is considered “good”, and the computed values of Tnd and r for each frequency are included in the TIP output data file. TIP files contain the following record types:

| <b>Record type</b> | <b>Description of Record Type</b>                                      |
|--------------------|--|
| 10                 | Header for current calibration data in configuration file              |
| 11                 | Current calibration data   |
| 30                 | Header for cal21 calibration results                                   |
| 31                 | Values of Tnd @ TkBB=290 K and r values for all frequencies in TIP Cal |

**Table 5-9. TIP calibration record types**

A copy of the current Tnd calibration data contained in the configuration file is copied to the top of the TIP file (record types 10 and 11). This provides a quick way to compare new TIP calibration derived values of Tnd to the current operational values as described in **Appendix E** on radiometer calibrations (page E-15). The values of Tnd are normalized to the value that would be observed when TkBB = 290 K.

### 5.3.9 LN2 Calibration File

LN2 calibration files contain the values of Tnd computed from individual LN2/Black Body observation sets during an LN2 calibration, for all channels specified in the configuration file. LN2 files contain the following record types:

| <b>Record type</b> | <b>Description of Record Type</b>  |
|--------------------|--|
| 10                 | Header for current calibration data in configuration file                          |
| 11                 | Current calibration data   |
| 30                 | Header for LN2 results   |
| 31                 | Values of Tnd @ TkBB=290 K for all frequencies in configuration file <sup>28</sup> |

**Table 5-10. LN2 calibration record types**

A copy of the current Tnd calibration data contained in the configuration file is copied to the top of the LN2 file (record types 10 and 11). This provides a quick way to compare new LN2 calibration derived values of Tnd to the current operational values. The values of Tnd are normalized to the value that would be observed when TkBB = 290 K.

## 5.4 Time Synchronization

The date/time stamp in files and output file names is derived from the date/time in the Microsoft Windows Operating System. The Windows calendar clock is updated using the GPS receiver time immediately before the beginning of each new set of output files.

## 5.5 Reprocessing

Users can reprocess level0 files with alternative calibration values or advanced algorithms to improve the accuracy or reduce the random noise in level1 data. Users can also reprocess level1 files with alternative retrieval algorithms. Contact Radiometrics' Customer Service for more information on reprocessing.

<sup>28</sup> These values are calculated using a simplified receiver model. When the calibration ends, updated values of Tnd, Alpha, and dTdG are calculated and written to mp.cfg.

## 6 Maintenance and Trouble Shooting

This Section provides information on routine maintenance and calibration of the profiling radiometer, including Surface Met Sensors, and the controlling computer.

### 6.1 *Instrument Maintenance*

#### 6.1.1 Radiometer Calibration

When installed at a permanent site and configured to operate on a continuous basis, the profiling radiometer should remain calibrated within specifications up to 6 months or longer in typical operating conditions. However, the calibration can be effected by Radome degradation, long-term drift, extreme weather, changes to the installation environment, and other factors.

The 22-30 GHz channels can be monitored easily by checking the TIP calibrations regularly. If **cal21** commands are included in the procedure in use, pressing the **T** key will produce real-time graphs of all the Noise Diode values (Tnd) in current use (straight lines), and a time series of the most recent values derived from real-time TIP calibrations. The numeric values of Tnd in current use are also indicated on the **T** display. If the daily averages of the new values of Tnd deviate by more than 0.5% from the Tnd values in use, then **consider** updating the values in use as described in **Appendix E** (page E-14). Note that it is normal for real-time values of Tnd to deviate from “truth” by up to 2% when the atmosphere is changing rapidly, such as when a front is moving through the area. Therefore, the calibration should be changed only if the average of many “good” TIP-derived Tnd values deviates from the values in use. Refer to **Appendix E** (page E-14) for the recommended procedures to identify when TIP calibration values are of good quality.

The 51-59 GHz and 22-30 GHz subsystems are predominantly independent. Therefore, the calibration status of one is not necessarily indicative of the other. The 51-59 GHz channels can only be calibrated using an external cryogenic target. Therefore, it is recommended that an LN2 calibration be performed every 6 months, or sooner if accuracy is in question. Follow the procedures in **Appendix E** to perform an LN2 calibration.

#### 6.1.2 Antenna Pointing Calibration

The accuracy of most sky observations is dependent on accurate antenna positions. The elevation angle accuracy is dependent on the accuracy of the leveling process described in Section 3.4. The instrument should be checked for proper leveling at least annually, following severe wind conditions, and any time TIP calibration attempts fail to pass the internal quality test more often than normally observed. Refer to Section 3.4 for proper leveling procedures.

If the optional Azimuth Positioner is installed, the instrument azimuth should be checked periodically. To check the azimuth reference position, end any data collection in

progress by pressing **Q** on the Control Computer, then cycle the profiling radiometer power by switching the power off for 10 seconds, then back on. Once the profiling radiometer reaches its azimuth index position, it should be reoriented with the Front Connector Panel due east and the antenna pointed in the north-south plane. To adjust the profiling radiometer azimuth reference, loosen the T-Bolt slightly and gently rotate the profiling radiometer so that the Front Connector Panel points due east, and then retighten the T-Bolt. The user may want to use a compass for this orientation. If so, the magnetic declination at the installed site must be included in the determination of true north.

### 6.1.3 Cleaning the Hydrophobic Radome Surface

## WARNING

**Do not use a hose to dispense water.**  
**Do not touch, wipe or scrub the Radome.**  
**Doing so will damage the hydrophobic properties of the coating.**

Airborne pollutants will eventually coat the Radome. Any foreign matter on the Radome may increase the observed sky temperatures. The Radome should be cleaned on a regular basis. **Do not touch or rub the Radome with a sponge or towel.** Doing so will degrade the hydrophobic material.

Rinse the Radome with clean (preferably distilled) water, with a hand-pump spray bottle.

A clean, contaminant-free hydrophobic coating will exhibit continuous water beading and shedding over the entire Radome surface when wetted. Areas that exhibit water collection or “sheeting,” indicate continued contamination (from dirt, debris, or stains).

Note that solar U.V. radiation, as well as some contaminants, will degrade the hydrophobic coating over time. If water does not bead on the Radome after cleaning, replace the Radome.

### 6.1.4 Radome Replacement

When the surface of the Radome becomes visibly dirty, and it cannot be rinsed clean as described above, the Radome should be replaced to ensure optimum performance of the profiling radiometer. The frequency of Radome replacement is site dependent and should be determined by periodic examination. Check the Radome every 30 days until a maintenance interval can be established by the user, based on local conditions.

#### NOTE:

**Observe the green dot that indicates the outside of the Radome.** Avoid touching the surface of the new Radome. The new Radome should be grasped only by the edges to ensure that the hydrophobic coating is not compromised. Tighten the Radome Retainer nut just enough to slightly compress the Radome. **Do not over-tighten the nuts.**

### 6.1.4.1 Method for Radiometers shipped before January 2012

In older models, remove the radiometer hood to access the internal nuts securing the Radome Window Retainer, as shown in Figure 6-1.

To replace the Radome, quit any current procedures in progress, (press **Q**) and turn off the power. Next, disconnect:

- the power cable (from source *first*, then at the profiling radiometer)
  - the short “pigtail” cable between the Superblower and radiometer
  - the GPS cable
1. Remove the hood by unlatching the 6 latches located along the sides.
  2. Carefully lift the hood straight up and off of the profiling radiometer.
  3. Place the back end of the hood on a clean work surface so that the inside is accessible.
  4. Support the hood as necessary to protect the IRT assembly, and remove all 4-40 Nylock nuts (32) securing the Radome Window Retainer as shown in Figure 6-1.
  5. After all of the nuts are removed, carefully remove the Radome Window Retainer and the old Radome.



**Figure 6-1. Radome replacement**

To install the new Radome, reverse the process. **Observe the green dot that indicates the outside of the Radome.** Avoid touching the surface of the new. Grasp the new Radome only by the edges or the area under the Radome retainer to ensure that the hydrophobic coating is not compromised. Tighten the nuts just enough to slightly compress the Radome. **Do not over-tighten the nuts.**

### 6.1.4.2 Method for Radiometers shipped after January 2012

In newer models, the Radome Window Retainer is secured to the radiometer by external screws, so a technician can replace the Radome without removing the radiometer hood. (See Figure 6-2.)

To replace the Radome, quit the current procedure in progress, if any, (Press **Q**) and turn off the power.

1. Remove the 32 external Phillips head screws and washers to unfasten the Radome retainer from the radiometer.

2. Slide the Radome Retainer off of the radiometer, without significantly changing the shape of the retainer.
3. Remove the old Radome.

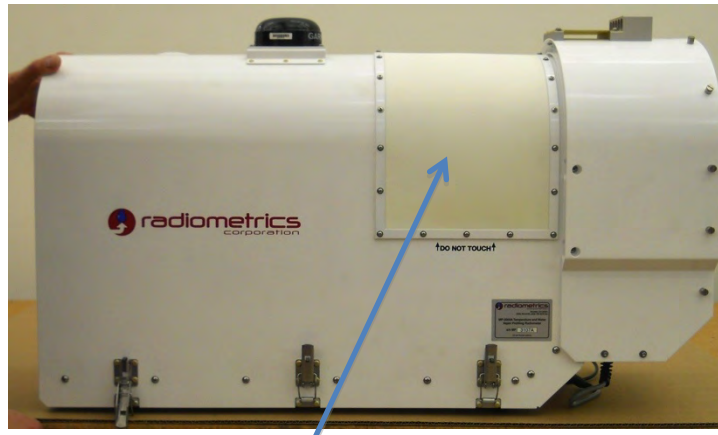

**Figure 6-2. Radome Retainer with external screws and washers**

4. Fit the new Radome within the Radome retainer, and insert the top (center) screws and washers into the retainer to act as positioning guides
5. Slide the Radome and retainer (together) onto the radiometer; align the two screws with the mating threaded holes and tighten the screws.

**NOTE:**

Do not over tighten the screws; doing so will deform the Radome Retainer. Only moderate compression is required to seal the Radome to the hood.

6. Install the remaining screws starting from the top and working down the sides; the screws along the bottom of the retainer should be installed last.
7. Tighten screws evenly in pairs, while going down the retainer.

### **6.1.5 Relative Humidity (RH) and Temperature Sensor Maintenance**

The ambient air probe is a precision instrument that will maintain calibration for 6 months or more in normal service. However, if dust or other local air pollution is excessive, the screen on the sensor may need to be cleaned more often. To access the Temperature and RH sensor, loosen the 10 thumbscrews that secure the Superblower End Cover. Gently remove the cover by pulling outward with the handle while holding the bottom lip. See Figure 6-3.

To clean the screen, the probe can be left in the mounting socket. Simply unscrew the screen and remove to the right. See Figure 6-4.

## CAUTION

The sensor is a delicate instrument and requires careful handling. Allow nothing to come in contact with the active sensor elements inside the screened protective cover.

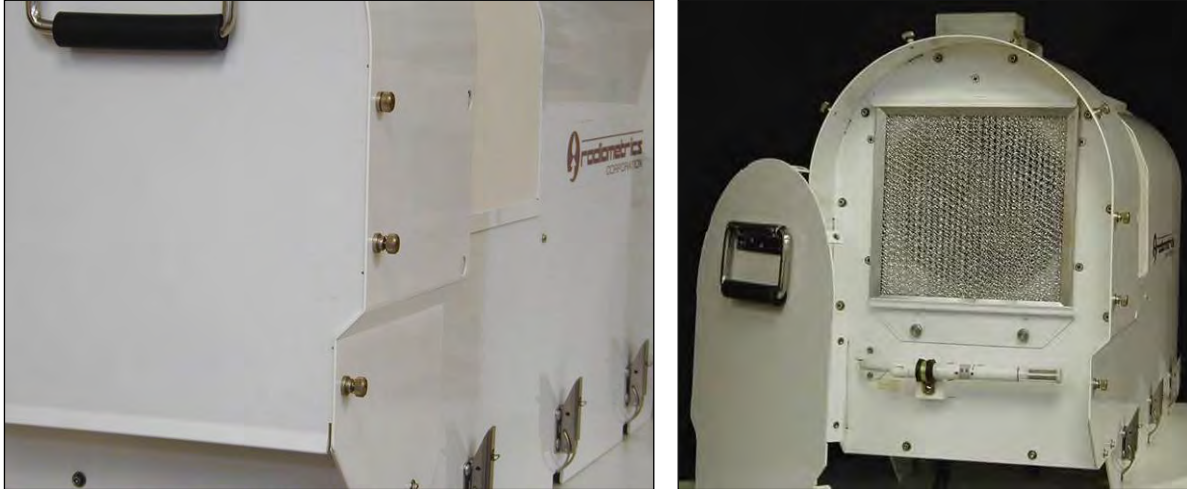

**Figure 6-3. Superblower End Cover removal**

To clean the screen in the field, use pure compressed air. Pure compressed air is available in small cans for cleaning photography equipment, computers, and other electronic equipment. Blow the compressed air through the screen from the inside to the outside as shown in Figure 6-4. Avoid using compressed air from an air compressor because oil and water from the compressor can contaminate the sensor screen.

If access to ultrasonic cleaning is available, it can be used with distilled water or pure isopropyl alcohol to clean the screen. Avoid chemical cleaners due to possible contamination.

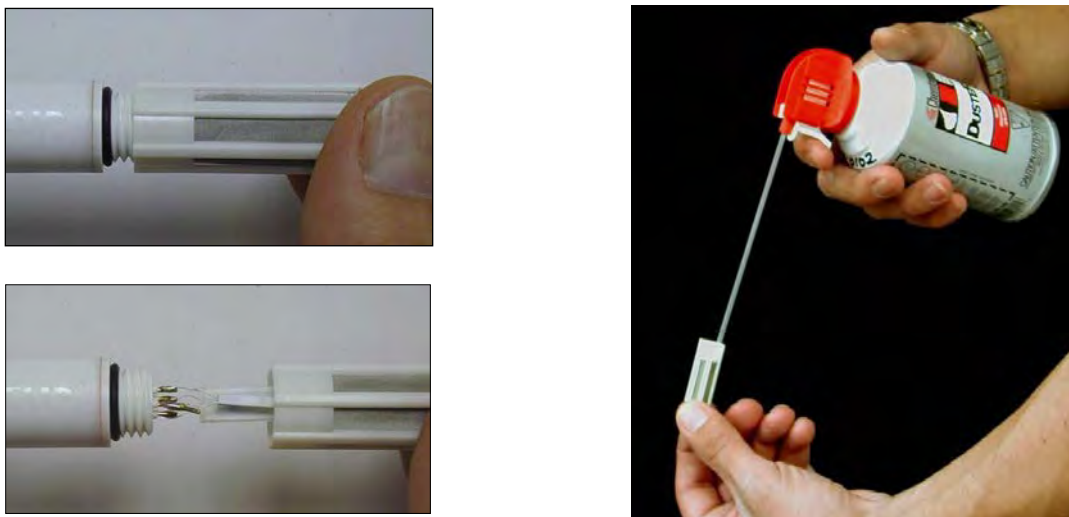

**Figure 6-4. Sensor screen removal and cleaning**



To remove the sensor for laboratory calibration or replacement, rotate the Gray Locking Collar on the probe until the black dots on the Gray Locking Collar line up with the black dots on each side of the Gray Locking Collar. Unplug the probe from the Gray Locking Collar by carefully pulling the probe to the right. See Figure 6-5.

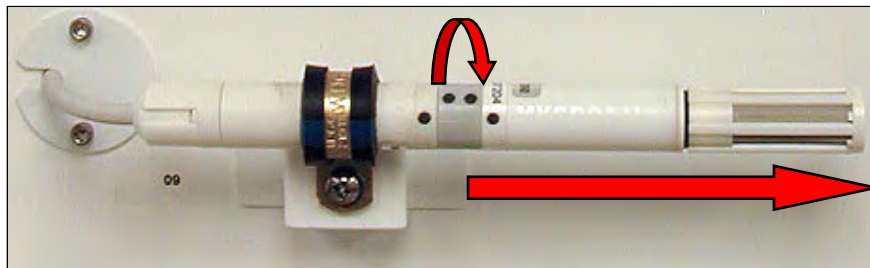

**Figure 6-5. Sensor removal**

On later models, the sensor has only an aluminum collar to loosen to remove the sensor. See Figure 6-6.

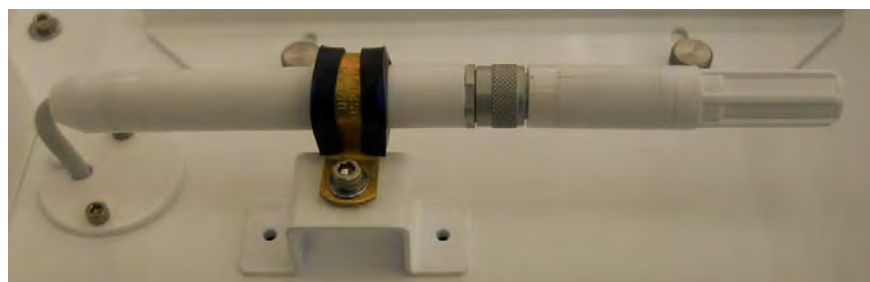

**Figure 6-6. Sensor removal, later models**

New sensors are available from Radiometrics. Users may calibrate the sensor in the laboratory, if necessary.

### **6.1.6 Superblower Filter Cleaning and Replacement**

The Superblower impeller produces a high volume of airflow. To protect the Radome and impeller, the intake is filtered with a standard aluminum mesh filter. This filter should be inspected and serviced periodically. The frequency of service is site-dependent and must be determined by the user. Following installation at a new site, inspect the filter every 30 days until a maintenance interval can be established by the user, based on local conditions.

To remove the filter, first remove the Superblower End Cover as described in Section 6.1.5. Then loosen the two thumb screws holding the filter retaining bracket, as shown in Figure 6-7. Remove the filter by sliding the retaining bracket down and lifting out the filter.

If the filter is not matted with insects or other difficult-to-remove debris, use compressed air used to clean it. For insects and other heavy debris, clean the filter with water and

mild detergent, and then rinse thoroughly. If the filter cannot be cleaned, due to excessive debris, replace with a new filter. Replacement filters are available only from Radiometrics.

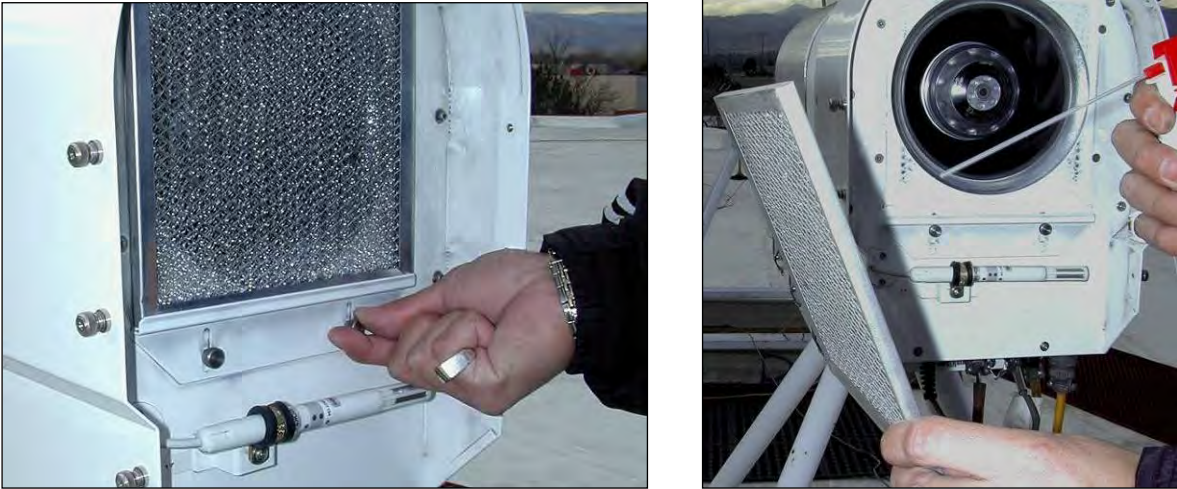
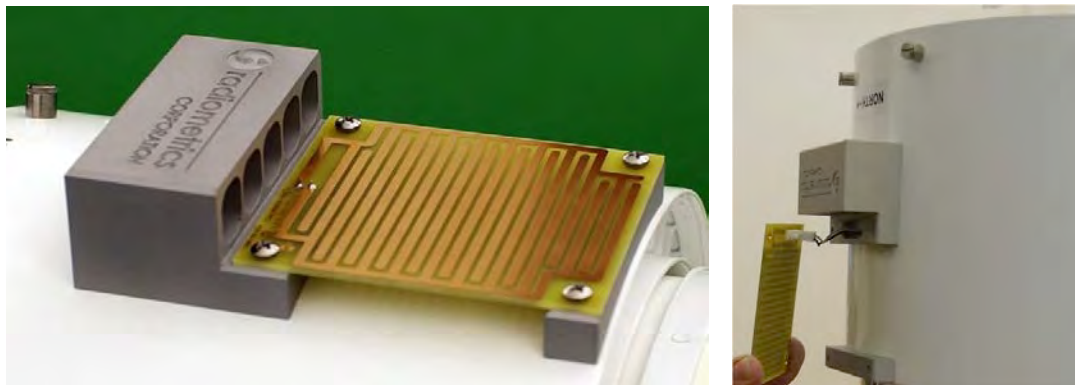

**Figure 6-7. Superblower filter removal and cleaning**

### 6.1.7 Rain Sense PCBA

The Rain Sense PCBA, located on the top of the Superblower, detects the presence of liquid water by measuring the resistance between the conductors. Excessive surface contamination from pollution, salt spray, etc. will alter the transfer function (volts/water-drop). The Rain Sense PCBA should be wiped clean with a nonabrasive cloth or paper towel as required to keep dirt and mineral deposits from accumulating. A pencil eraser can also be used to remove oxidation and deposits.

The board is gold plated to minimize corrosion but will degrade over time in corrosive environments. If the rain sensor fails to provide satisfactory service after cleaning, it may need to be replaced, as described in **Appendix F**. Replacement boards are available from Radiometrics.



**Figure 6-8. Close-up view of Rain Sense PCBA; connector on underside (right)**

### 6.1.8 IRT Window Maintenance

The IRT window located on the top of the profiling radiometer. It should be checked periodically for contamination. For accurate cloud base temperatures, the window surface must be free of dust and other contamination. The frequency of service is site-dependent and must be determined by the user. Following installation at a new site, inspect the IRT window every 30 days until a maintenance interval can be established by the user, based on local conditions.



**Figure 6-9. GPS Receiver on the left; IRT window on the right**

Use a standard camera lens cleaning kit (available from photography stores) to clean a soiled window.

### 6.1.9 Cables

Normally, the power and data cables do not require any periodic maintenance. However, it is good practice to inspect the cables periodically to ensure that weather, accident, rodents, etc. have not damaged them.

## 6.2 Control Computer

No periodic maintenance is required for the Control Computer hardware beyond what is recommended by the computer manufacturer. Refer to the separate computer manufacturer documentation supplied for computer maintenance suggestions.

### 6.2.1 Operating System Updates

## WARNING

Radiometrics advises against enabling automatic updates. Automatic updates can interfere with normal data collection, so it is better to install updates manually, at a time convenient to the user.

Microsoft releases updates to the Windows Operating System software (OS) quite often. The OS can be configured to update automatically or notify the user that updates are

available. It is generally advisable to keep the OS up to date with revisions as they are released.

### 6.2.2 Operating Code Updates

Radiometrics may release updates to the Operating Code from time to time to enhance performance, add features or fix bugs. Generally, these updates can be installed by replacing the application file (**mp.exe**) in the Operating Folder, without changing any other files. Occasionally, updates require the installation of additional files, or the modification of some existing files. Detailed installation instructions will be provided with all new code releases. Contact Radiometrics Customer Service for information on the latest codes available, and advice on the best code to use for a given application.

### 6.2.3 Neural Network and Procedure File Updates

Neural networks are specific to the site where the radiometer will be operated. If the radiometer is moved from the original site and the new site's elevation is more than 100 meters different from the old site and/or has a radically different climate, order new neural networks from Radiometrics. Place the neural network files (.net extension) and the procedure files (.prc extension) in the main operating directory. Place the macro files (.rmc extension) in the macro subdirectory. The new procedure files will then be available for selection when the operating program is run.

### 6.2.4 Firmware Updates

The MCM and microwave receivers store firmware in flash memory. Update this firmware from time to time using a code download tool installed on the control computer.<sup>29</sup> If any of the firmware needs to be updated, Radiometrics will supply detailed instructions on the procedure. Note that the factory can install the MCM firmware for you via Internet.

### 6.2.5 Virus Protection and Firewall

Radiometrics does not supply virus protection software with Control Computers. However, if users connect the Control Computer to the Internet, they should enable or add appropriate firewall and virus protection, provided it is configured to operate without restarting the computer from time to time.

### 6.2.6 Error Messages

If the Operating Code encounters a fatal or nonfatal error, it will attempt to write an Error Message. These are reported in record **type 0** records in the lv0.csv file with the device name (one of MCM, RCV0, RCV1, EL, or AS — some devices may not be present in a particular instrument), the number of errors, followed by the numeric error codes. If the user encounters problems requiring factory assistance to resolve, be prepared to give

---

<sup>29</sup> The Downloader Tool can also be installed on any other computer as required to update radiometer firmware.

the Radiometrics customer service representative information about the Error Message history. For more information on Error Messages, refer to **Appendix B**.

## 7 Warranty and Service

Radiometrics warrants its profiling radiometers for one year from the date of delivery against defects in workmanship and materials under normal use and service. Radiometrics will repair or replace, at Radiometrics option, any equipment found to be defective within this warranty period, EXW Boulder Colorado. Customers are responsible for the cost of all inbound and outbound freight, insurance and taxes, if any. This warranty excludes the control computer, which is covered under the original equipment manufacturer's warranty.

### CAUTION

**Unauthorized disassembly of the radiometer, its components or subassemblies will void all warranties.**

**The radiometer cabinet cover is closely fit to seal against intrusion of insects, spiders, wind-blown dust, sand, water and ice. Use caution if it is necessary to remove the cabinet cover. After unbuckling the latches on both sides of the cabinet, lift the cover evenly and gently, by using the handles on the cabinet cover. Forcing the cover unevenly can result in damage to the radiometer and voiding of the Warranty.**

**Substituting another computer for the Control Computer supplied by Radiometrics, or changing the factory software load and settings, may void our software and control computer Warranty support obligation. Should such changes require RDX remote support, Radiometrics will invoice these services to you at our normal hourly support rates.**

For information or service, contact Radiometrics as indicated below. Be prepared to describe your problem in detail. If field repair is not considered possible, request a Return Materials Authorization (RMA). Radiometrics will remedy your problem as soon as possible and return the unit.

The profiling radiometers are protected under U.S. and foreign patents. The software and firmware are copyrighted.

#### **Please direct inquiries to:**

Radiometrics Corporation  
4909 Nautilus Court North, Ste. 110  
Boulder, CO 80301  
USA

Tel: (303) 449-9192  
Fax: (303) 786-9343

## 7.1 *European Certification*

The MP-3000A has received European Certification in conformance with the European Union Directives:

- 73/23/EEC (93/68/EEC) Low Voltage Directive
- 89/336/EEC Electromagnetic Compatibility Directive

Based on the following standards:

- EN61010 Safety of Electrical Equipment for Measurement, Control, and Laboratory Use
- EN 55022 (Class A) Limits and methods of measurements of radio interference characteristics of information technology equipment.
- EN 50082-1 Electromagnetic compatibility - Generic immunity standard - Industrial environment

## 7.2 *Symbols Legend*

Below is a description of the safety marking symbols that appear on the profiling radiometer. These symbols provide information about potentially dangerous situations which can result in death, injury, or damage to the instrument and other components.





# radiometrics

## Profiler Operator's Appendices

- **MP-3000A**
- **MP-2500A**
- **MP-1500A**



### **Radiometrics Corporation**

4909 Nautilus Court North, Suite 110

Boulder, CO 80301 USA

1+303 449-9192 (tel)

1+303 786-9343 (fax)

<http://radiometrics.com>

**Revision D**  
**Windows 7 OS**

*Table of Contents*

|                    |   |            |
|--------------------|---|------------|
| <b>Appendix A:</b> | <b>TP-2000 Tripod Assembly .....</b>  | <b>A-1</b> |
| <b>Appendix B:</b> | <b>Radiometer Theory of Operation .....</b>                                       | <b>B-1</b> |
| <b>Appendix C:</b> | <b>Error Messages for A Series Radiometers, Version 6.xx Operating Code .....</b> | <b>C-1</b> |
| <b>Appendix D:</b> | <b>VizMet-B User's Guide.....</b>   | <b>D-1</b> |
| <b>Appendix E:</b> | <b>Radiometer Calibrations.....</b>   | <b>E-1</b> |
| <b>Appendix F:</b> | <b>Cable Data .....</b>   | <b>F-1</b> |
| <b>Appendix G:</b> | <b>Removal and Replacement of Common FRUs.....</b>                                | <b>G-1</b> |
| <b>Appendix H:</b> | <b>Azimuth Positioner Installation and Removal .....</b>                          | <b>H-1</b> |
| <b>Appendix I:</b> | <b>Specifications, Weights and Dimensions .....</b>                               | <b>I-1</b> |



## *List of Figures*

|  |      |
|--|------|
| Figure A-1. Radiometrics TP-2000 Tripod parts .....  | 1    |
| Figure A-2. Tripod assembly components .....   | A-3  |
| Figure A-3. Tripod fully assembled.....  | A-3  |
| Figure B-1. Absorption spectrum of a typical mid-latitude atmosphere for two altitudes and two water vapor densities ..... | B-1  |
| Figure B-2. Atmospheric absorption spectra near 60 GHz .....   | B-2  |
| Figure C-1. Sample level0 error line .....   | C-2  |
| Figure D-1. Home page and login for radiometer .....   | D-1  |
| Figure D-2. Users tab .....  | D-3  |
| Figure D-3. The Configure tab .....  | D-3  |
| Figure D-4. That Status/Control tab .....  | D-4  |
| Figure D-5. Sample error message .....   | D-5  |
| Figure D-6. The File Manager tab .....   | D-6  |
| Figure D-7. The Monitor tab (3D Color tab selected).....   | D-7  |
| Figure D-8. Numerical coordinates and menus .....  | D-8  |
| Figure D-9. The Profiles tab.....  | D-9  |
| Figure D-10. The 2D Line tab .....   | D-11 |
| Figure D-11. The Calibrate tab .....   | D-13 |
| Figure D-12. Imaginary line “averaged” through noise diode temperature.....  | D-14 |
| Figure D-13. Calibration data: mp.cfg file superimposed over a CSV file .....  | D-15 |
| Figure D-14. Uninstalling the VizMet-B program .....   | D-17 |
| Figure D-15. Uninstalling the Java 7 Update 9 program .....  | D-18 |
| Figure D-16. Navigating to the local disk.....   | D-18 |
| Figure D-17. Selecting the Delete option.....  | D-19 |
| Figure D-18. Deciding to delete the RailsInstaller folder .....  | D-19 |
| Figure D-19. Deciding to delete the sites folder .....   | D-19 |
| Figure D-20. Resetting UAC notification setting .....  | D-21 |
| Figure D-21. Setup wizard welcome screen.....  | D-22 |
| Figure D-22. Web server port.....  | D-22 |
| Figure D-23. Setup install location .....  | D-23 |
| Figure D-24. Setup shortcuts location .....  | D-23 |
| Figure D-25. Setup ready to install.....   | D-24 |
| Figure D-26. Installing .....  | D-24 |
| Figure D-27. RailsInstaller setup.....   | D-25 |
| Figure D-28. License agreement .....   | D-25 |
| Figure D-29. Installation location .....   | D-26 |
| Figure D-30. Files installing .....  | D-26 |
| Figure D-31. Completing the setup.....   | D-27 |
| Figure D-32. Command prompts (left) and disappearing shell window (right) .....  | D-27 |
| Figure D-33. Typing 'exit' in the command prompt .....   | D-27 |
| Figure D-34. Notice of completion .....  | D-28 |
| Figure D-35. Starting Java setup.....  | D-28 |
| Figure D-36. Notice of Java version .....  | D-29 |
| Figure D-37. Java setup .....  | D-29 |
| Figure D-38. Java installation status.....   | D-30 |
| Figure D-39. Success notification .....  | D-30 |
| Figure E-1. Cryogenic Target used to calibrate microwave-profiling radiometers.....  | E-1  |
| Figure E-2. Radiometer with Saddle and Cryogenic Target in place.....  | E-2  |
| Figure E-3. Saddle for Cryogenic Target, properly seated .....   | E-3  |
| Figure E-4. Proper method for safely pouring LN2 into the Cryogenic Target.....  | E-4  |

|   |      |
|---|------|
| Figure E-5. LN2 calibration display .....   | E-5  |
| Figure E-6. Tnd values from user LN2 calibration (Excel plot).....  | E-6  |
| Figure E-7. Example of B&L Cryogenic Target for MP-3000A (Excel plot).....                                | E-7  |
| Figure E-8. Example of B&L temperature error for MP-3000A (Excel plot) .....                              | E-8  |
| Figure E-9. Example of B&L statistics for MP-3000A (Excel plot) .....                                     | E-8  |
| Figure E-10. Dewars used for storing and handling LN2 .....   | E-9  |
| Figure E-11. Example of Channel Block Configuration File.....   | E-12 |
| Figure E-12. Example of TIP data plotted as a function of time .....                                      | E-16 |
| Figure E-13. Example of a processed <i>TIP</i> data file displayed in Excel .....                         | E-17 |
| Figure E-14. Superblower with End Cover removed; sensor and filter.....                                   | E-18 |
| Figure E-15. Standard 600 – 1100 mb Pressure Sensor .....   | E-19 |
| Figure E-16. Typical Rain Sensor transfer function .....  | E-20 |
| Figure E-17. Rain Sensor .....  | E-21 |
| Figure E-18. Left: KT-15 IRT Assembly; Right: Top view of Cabinet with IRT Window .....                   | E-22 |
| Figure F-1. RS-422 Com cable pin-out.....   | F-1  |
| Figure G-1. Reset the latch with the bail off of the strike.....  | G-2  |
| Figure G-2. One person, lifting the radiometer hood straight up .....                                     | G-3  |
| Figure G-3. Side view of MP-3000A radiometer with hood removed .....                                      | G-3  |
| Figure G-4. IRT on right side of radiometer .....   | G-5  |
| Figure G-5. Using wire cutters to remove cable-tie retainers .....  | G-6  |
| Figure G-6. Underside of IRT, with pins (left) and IRT data/power cable harness (right) .....             | G-6  |
| Figure G-7. 10mm wrench (left and middle) or socket head (right) to disconnect IRT from its bracket ..... | G-7  |
| Figure G-8. Fastening thermal sensor cable pairs with cable-tie retainers .....                           | G-7  |
| Figure G-9. IRT window mount cap and replacement O-ring.....  | G-8  |
| Figure G-10. Removing radiometer hood to reveal MCM PCBA .....  | G-9  |
| Figure G-11. Close-up view of MCM PCBA, with two plastic latches.....                                     | G-9  |
| Figure G-12. Pulling release MCM PCBA latches.....  | G-10 |
| Figure G-13. Empty card cage, showing card rails .....  | G-10 |
| Figure G-14. Removing Front Connector Panel.....  | G-11 |
| Figure G-15. Front of Power Supply, showing two connection shields .....                                  | G-12 |
| Figure G-16. Front of Power Supply, showing two connection shields .....                                  | G-13 |
| Figure G-17. Screw/lock washer/flat washer combination.....   | G-14 |
| Figure G-18. Power Supply mounting screws .....   | G-14 |
| Figure G-19. Interconnect PCBA; note all the connections .....  | G-15 |
| Figure G-20. Interconnect PCBA with no cables attached.....   | G-16 |
| Figure G-21. Close up detail of connections +12VD and V1 .....  | G-17 |
| Figure G-22. Interconnect PCBA; note position of Fuse .....   | G-18 |
| Figure G-23. Loosened thumbscrews on Superblower cover; cover removed (right).....                        | G-20 |
| Figure G-24. S3 Sensor removal .....  | G-20 |
| Figure G-25. S3 Temperature and RH Sensor, showing receptors.....   | G-21 |
| Figure G-26. Loosened thumbscrews on Superblower cover; cover removed (right).....                        | G-22 |
| Figure G-27. HC2-S3 probe removal .....   | G-23 |
| Figure G-28. HC2-S3 Ambient Air Probe, showing receptors .....  | G-23 |
| Figure G-29. Pressure Sensor on right side of radiometer .....  | G-24 |
| Figure G-30. Cable to Pressure Sensor, disconnected (right) .....   | G-25 |
| Figure G-31. Detaching Pressure Sensor from its frame .....   | G-25 |
| Figure G-32. Radiometer hood on workbench .....   | G-26 |
| Figure G-33. Disconnecting Superblower cable / cable disconnected.....                                    | G-27 |
| Figure G-34. Removing Superblower screws (two on each side) .....   | G-27 |
| Figure G-35. Lifting Superblower away from the radiometer hood .....                                      | G-28 |
| Figure G-36. GPS receiver attached to GPS Mounting Plate with three screws (right).....                   | G-30 |
| Figure G-37. Rain Sense PCBA, detached and showing cable on the right .....                               | G-31 |
| Figure H-1. Underside view of radiometer with Mounting Plate .....  | H-3  |
| Figure H-2. Underside of radiometer with Azimuth Drive installed.....                                     | H-4  |

## *List of Tables*

|   |             |
|---|-------------|
| <b>Table 1. MCM errors .....</b>  | <b>C-7</b>  |
| <b>Table 2. RCV0 and RCV1 errors .....</b>  | <b>C-11</b> |
| <b>Table C-3. Elevation error codes .....</b>   | <b>C-12</b> |
| <b>Table C-4. Azimuth error codes .....</b>   | <b>C-12</b> |
| <b>Table 5. MP.exe v6.xx error messages .....</b>                                     | <b>C-15</b> |
| <b>Table 6. Typical contributions to Cryogenic Target Black Body temperature.....</b> | <b>E-13</b> |

## Appendix A: TP-2000 Tripod Assembly

Unpack and inspect the Tripod parts for signs of damage or missing pieces. The following parts should be included:

- (3 ea.) Foot Assembly (A)
- (3 ea.) Telescoping Leg Assembly (B)
- (3 ea.) Strut (C)
- (1 ea.) Triangular Mounting Plate with eyebolt (D)
- (1 ea.) Hardware Kit containing:

### Foot Assembly Hardware:

- (3) 3/8" x 1-3/4" cap screws
- (6) flat washers
- (3) lock nuts

### Cross Strut Hardware:

- (6) 3/8" x 1" cap screws
- (6) Lock nuts

### Top Plate Hardware:

- (6) 3/8" x 3/4" cap screws

### (1 ea.) Tool Kit Containing:

- (1) 1/4" Allen wrench
- (1) 5/16" Allen wrench
- (1) 9/16" box / open-end wrench
- (1) 9" Magnetic bubble level

### (1 ea.) Center Pull Anchor Kit

#### Containing:

- (3) SS oval threaded connector
- (1) SS turnbuckle
- (1) SS eyebolt
- (3) SS 3/16" corrosion resistant chain

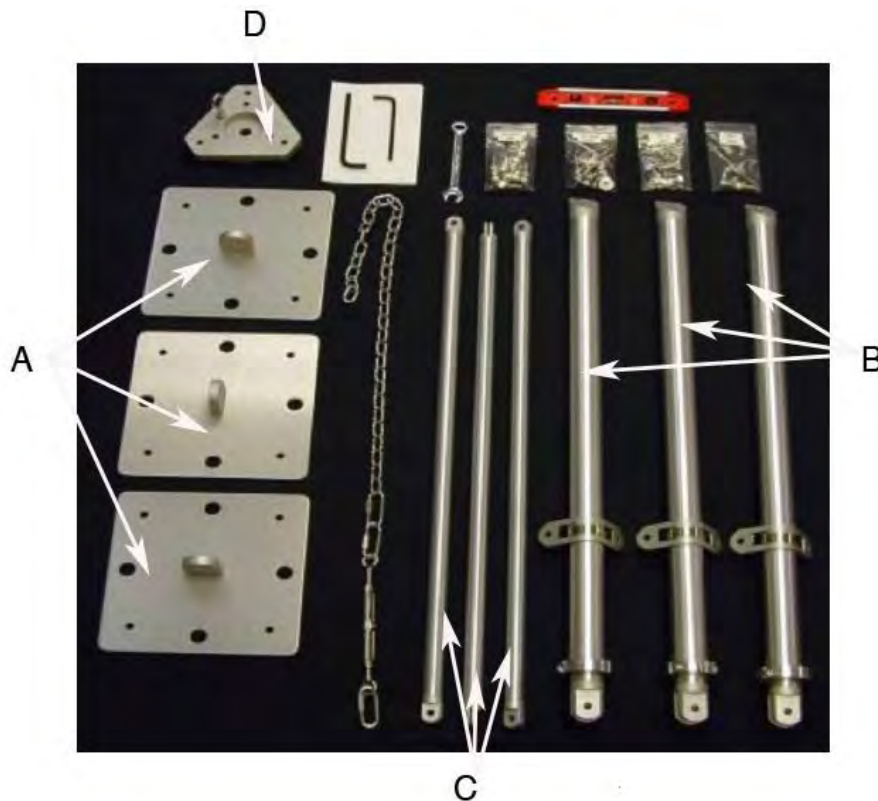

Figure A-1. Radiometrics TP-2000 Tripod parts

## Assembly Instructions

1. Attach (1) foot assembly to each leg assembly using (1) 3/8" x 1-3/4" cap screw, (2) flat washers, and (1) 3/8" lock nut. DO NOT TIGHTEN the screws at this step.
2. Attach the other end of each leg assembly to the triangular top plate using (2) 3/8" x 3/4" SS cap screws for each leg. DO NOT TIGHTEN the screws at this step.
3. Attach the (3) cross struts to the leg brackets using (2) 3/8" x 1" cap screws and (2) 3/8" lock nuts on each cross strut.
4. Tighten all screws using 5/16" Allen wrench and 9/16" box wrench.
5. Loosen the (3) collar clamps using the 1/4" Allen wrench to adjust to desired height.
6. Extend the lower leg by pulling downward on the foot.

Repeat this step for each leg as required to set instrument height.

7. If the site is not level, adjust the legs to different lengths as necessary to level the triangular Mounting Plate. Retighten each collar clamp.

For more detail on leveling the Tripod, see Section 3.4 of the Profiler Operator's Manual.

## Securing the Tripod

The Tripod can be secured using any of the following methods:

- A. **Center-Pull Anchor Chain:** The supplied center-pull anchor chain and turnbuckle assembly provides a robust way to secure the Tripod to the surface below using a single eyebolt. This method is especially useful when the height may need to be adjusted from time to time. If a single secure anchor bolt can be located directly under the Tripod, follow these steps:

1. Position the Tripod directly over the anchor bolt.
2. Attach the oval threaded connector of the pull chain assembly to the eyebolt on the triangular top plate.
3. Attach the other end of the chain to the anchor bolt using the threaded chain link, (moved to the required position on the chain).
4. When the chain is attached at both ends and the Tripod is leveled at the desired height, take up the slack with the turnbuckle. A downward force of 25-30 lb. is sufficient.

- B. **Lag Bolts:** Use lag bolts to secure the Tripod feet, via their small holes.
- C. **Tent Stakes:** Use tent stakes or similar securement pieces to secure the Tripod feet, via their large holes.
- D. **Sand bags:** Apply sand bags or similar dead weight to the feet.

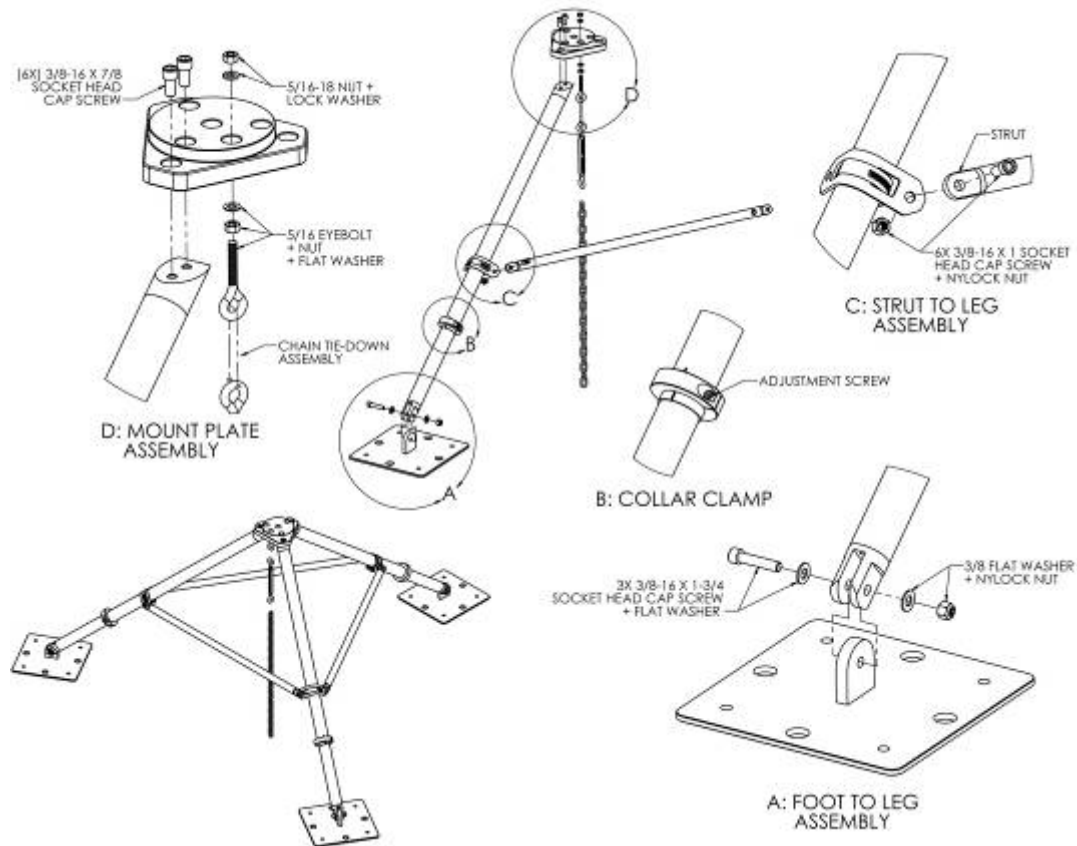

**Figure A-2. Tripod assembly components**

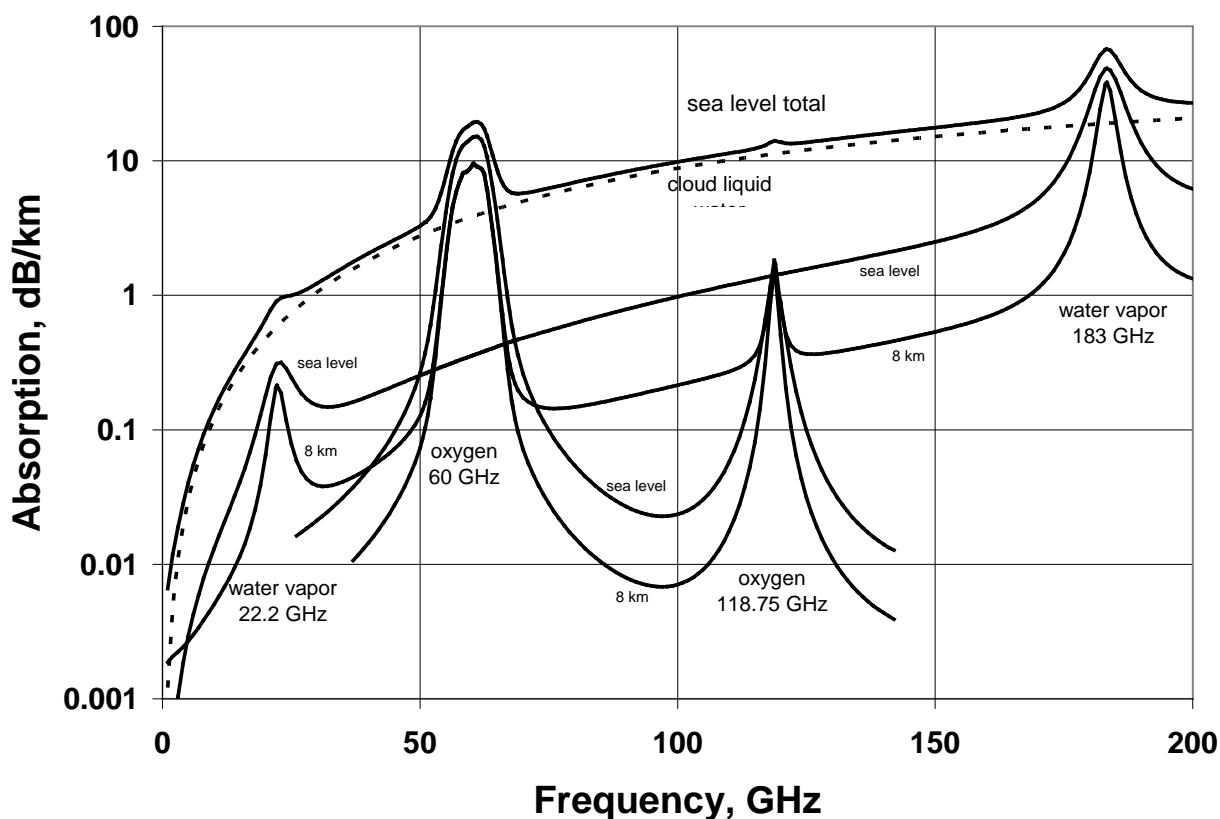

**Figure A-3. Tripod fully assembled**

This page left intentionally blank.

## Appendix B: Radiometer Theory of Operation

This section describes the theory of operation for the MP-3000A. Ground-based microwave profiling methods make use of atmospheric radiation measurements in the 20 to 200 GHz region. The atmospheric absorption spectrum at several altitudes for a typical mid latitude atmosphere is shown in Figure B-1. Two altitudes and two water vapor densities are shown. The features near 22 GHz are water vapor resonances that are pressure broadened according to the pressure altitude of the water vapor distribution. The feature near 60 GHz is an assemblage of atmospheric oxygen resonances. The cloud liquid water emission spectrum has no resonances in this frequency range, and increases approximately with the second power of frequency in this region.



**Figure B-1. Absorption spectrum of a typical mid-latitude atmosphere for two altitudes and two water vapor densities**

Temperature profiles can be obtained by measuring the radiation intensity, or brightness temperature, at points along the side of the oxygen feature at 60 GHz. By sampling the brightness temperatures outward from line center, where the opacity is so great that all signal originates from the atmosphere close to the antenna, on to the “wing of the line,” where the radiometer “sees” further into the atmosphere, the instrument can obtain



altitude information. Emission at any altitude is proportional to local temperature and density of oxygen; thus the temperature profile can be retrieved.

Water vapor profiles can be obtained by observing the intensity and shape of emission from pressure broadened water vapor lines. The line near 22 GHz is suitable for ground based profiling in relatively moist areas. The emission from water vapor is in a narrow line at high altitudes and is pressure broadened at low altitudes. The intensity of emission is proportional to vapor density and temperature. Scanning the spectral profile and mathematically inverting the observed data can therefore provide water vapor profiles.

Limited resolution cloud liquid water profiles can be obtained by measuring the contribution of cloud liquid water to atmospheric spectral features of varying opacity. Cloud liquid information in the 22 to 30 GHz and 51 to 59 GHz bands is used by the MP-3000A radiometer to produce a liquid profile. Cloud base altitude information derived from the optional IRT improves the water vapor and liquid water profile retrievals.

The absorption of the atmosphere in the vicinity of the assemblage of oxygen lines centered at 60 GHz at sea level and at 4 km is shown in Figure B-2. Pressure broadening smears the numerous oxygen lines into one broad feature. The 22 GHz water vapor line exhibits similar pressure broadening.

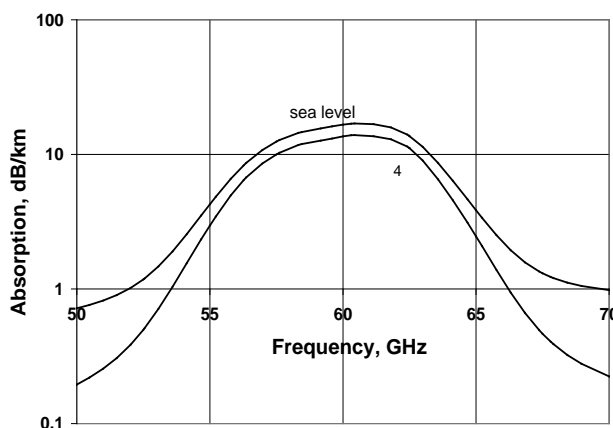

**Figure B-2. Atmospheric absorption spectra near 60 GHz**

Surface relative humidity, temperature, and barometric pressure are measured by the Profiling Radiometer and used in the determination of profiles. Additionally, an optional vertically pointed IRT indicates the presence of cloud, and measures cloud base temperature if clouds are present. Knowing cloud base temperature yields the vapor density at cloud base (at saturation), and combined with the retrieved temperature profile, yields cloud base altitude. These physical measurements are important constraints for profile retrieval.

### ***Brightness Temperature Transfer Function***

The Profiling Radiometer uses a state-of-the-art algorithm and calibration system to derive sky brightness temperature from the *level0* observations (receiver detector output voltage). This algorithm makes use of factory measured calibration coefficients to compensate for the small but finite effects of ambient temperature and system non-linearity. The algorithm and calibration system also include proprietary methods for the elimination of most “1/f” noise in observations, thereby significantly reducing the overall noise compared to competing technologies. The transfer function is as follows:

$$\mathbf{Tsky = (Vsky/gain\_sky)^{(1/\alpha)} - Trcv\_sky}$$

Where measured values are:

- Vsky** = integrated receiver output from a sky observation with Noise Diode off
- Vsky\_nd** = integrated receiver output from a sky observation with Noise Diode on
- Vbb** = integrated receiver output from an ambient Black Body target observation with Noise Diode off
- Vbb\_nd** = integrated receiver output from an ambient Black Body target observation with Noise Diode on
- TkBB** = Black Body target effective radiation temperature<sup>1</sup>

Where calibrated parameters are:

- $\alpha$**  = non-linearity correction exponent
- Tnd290** = Noise Diode temperature @ TkBB = 290K
- K1 - K4** = factory calibrated temperature coefficients
- dTdG** = receiver hardware specific parameter

Where calculated values are:

- gain\_sky** = gain during sky observation =  $[(Vsky\_nd^{(1/\alpha)} - Vsky^{(1/\alpha)}) / (Tnd290 + TC)]^{\alpha}$
- Trcv\_sky** = Receiver temperature during sky observation =  $Trcv\_bb + dTdG * (gain\_sky - gain\_bb)$
- gain\_bb** = gain during ambient Black Body Target observation =  $[(Vbb\_nd^{(1/\alpha)} - Vbb^{(1/\alpha)}) / (Tnd290 + TC)]^{\alpha}$
- Trcv\_bb** = Receiver temperature during ambient Black Body Target observation =  $(Vbb/gain\_bb)^{(1/\alpha)} - TkBB$
- TC** =  $K1 + K2 * TkBB + K3 * TkBB^2 + K4 * TkBB^3$

<sup>1</sup> TkBB is the measured physical temperature of the ambient Black Body target adjusted for implementation bias.

## Appendix C: Error Messages for A Series Radiometers, Version 6.xx Operating Code

Errors are reported in the level0 (lv0.csv) file, when operating in single-user mode. The most recent error also appears on-screen in the lower-left corner; the error will remain for the entire day.

In the lv0.csv files, all errors have a record type of 0 so that they sort to the top when the file is sorted by record type. There are two basic types of errors:

- Radiometer operating program errors produced by the operating code, usually due to configuration problems or Control Computer problems)
- Radiometer sub-system errors – these errors will often cause operating code errors as well.

### Radiometer operating program errors

These errors do not have an error code and are descriptive of the problem that occurred. They include problems with the computer, operating system and file system. An example of these operating program errors is an inability to open the serial port connection to the instrument because it is in use by another program or because the serial port specified in mp.cfg does not exist. File system errors include attempts to open files that do not exist (for example, specifying non-existent neural network files or macro files in a procedure file) and errors related to an inability to access a file (because it is locked by another program, read-only, or on a network drive that is not accessible for some reason).

There are also errors related to incorrect procedure files. These include specifying frequencies in TRCVCAL and OBS commands that are not present in the mp.cfg file. This results in a “Factory Calibration Not Available” error. Specifying a frequency in an OBS command that has not previously appeared in a TRCVCAL command will result in an

- **ERROR – Trcv not available at f = xxxxx** and/or
- **ERROR – Gbb not available at f = xxxxx**

...where **xxxxx** if the frequency in MHz.

Errors related to problems communicating with the instrument include RS-232 timeout errors (the instrument did not respond in the expected time) and command retry errors. If this happens only once, there is probably no problem, but repeated timeouts and retries indicate a more serious problem. The operating code should be stopped, the instrument power turned off for 30 seconds, then back on and the operating code

restarted. For a list of Operating Errors, refer to the MP.exe v6.xx error messages later in this Appendix.

### Radiometer subsystem errors

There are five subsystems in the instrument that produce numerical errors. These are reported in record **type 0** records in the lv0.csv file with the device name (one of MCM, RCV0, RCV1, EL, or AZ — some devices may not be present in a particular instrument), the number of errors, followed by the numeric error codes. An example of a radiometer subsystem error is shown in Figure 4. The error message is interpreted as:

- a. record number 143
- b. date (May 15, 2011)
- c. time (10:29:00)
- d. record type (0)
- e. device reporting the error (MCM)
- f. number of errors (001)
- g. error code 20

a.            b.                            c.            d.    e.            f.    g.

|   |
|---|
| 143, 05/17/2011, 10:29:00, 0, MCM, 001, 020 |
|---|

**Figure C-1. Sample level0 error line**

A complete list of radiometer subsystem error messages appears on the following pages.

**MCM errors**

| <b>Error Number</b> | <b>Description</b>  |
|---------------------|---|
| 0                   | MCM input buffer overflow for port A                                |
| 1                   | Not used  |
| 2                   | MCM input buffer overflow for port C                                |
| 3                   | MCM input buffer overflow for port D                                |
| 4                   | Not used  |
| 5                   | Not used  |
| 6                   | Not used  |
| 7                   | Not used  |
| 8                   | Attempted print of float with over 8 digits total                   |
| 9                   | Invalid parameter passed to sprintf function                        |
| 10                  | ADC calibration timeout   |
| 11                  | Not used  |
| 12                  | Not used  |
| 13                  | Not used  |
| 14                  | Not used  |
| 15                  | Not used  |
| 16                  | Not used  |
| 17                  | Not used  |
| 18                  | Not used  |
| 19                  | Not used  |
| 20                  | Incorrect checksum from DIO   |
| 21                  | Incorrect data from DIO   |
| 22                  | Not used  |
| 23                  | GPS string overflow   |
| 24                  | IRT string overflow   |
| 25                  | Attempt to start an observation while an observation is in progress |
| 26                  | Not used  |
| 27                  | Attempt to set pulse width to invalid value                         |
| 28                  | Wait for I2C attention line timeout                                 |
| 29                  | Not used  |
| 30                  | Not used  |
| 31                  | Not used  |
| 32                  | Not used  |
| 33                  | Not used  |
| 34                  | Not used  |
| 35                  | Not used  |
| 36                  | Not used  |
| 37                  | Not used  |
| 38                  | Not used  |

| <b>Error Number</b> | <b>Description</b>   |
|---------------------|--|
| 39                  | Not used   |
| 40                  | Not used   |
| 41                  | Attempted to set synthesizer at end of observation                 |
| 42                  | Failed to setup ADC for observation                                |
| 43                  | Not used   |
| 44                  | Not used   |
| 45                  | Not used   |
| 46                  | Not used   |
| 47                  | Not used   |
| 48                  | Update observation function failed                                 |
| 49                  | Update tilt function failed  |
| 50                  | Not used   |
| 51                  | Not used   |
| 52                  | Not used   |
| 53                  | Not used   |
| 54                  | Tilt timeout error returned by motor controller                    |
| 55                  | Tilt X error returned by motor controller                          |
| 56                  | Tilt Y error returned by motor controller                          |
| 57                  | Tilt X and Y error returned by motor controller                    |
| 58                  | Unknown error returned by motor controller                         |
| 59                  | Not used   |
| 60                  | MCM code space checksum failed                                     |
| 61                  | Not used   |
| 62                  | Attempted to write invalid frequency to synthesizer                |
| 63                  | Not used   |
| 64                  | Not used   |
| 65                  | C command failed to configure receiver 0                           |
| 66                  | C command failed to configure receiver 1                           |
| 67                  | R command failed to retrieve housekeeping data from receiver 0     |
| 68                  | R command failed to retrieve housekeeping data from receiver 1     |
| 69                  | Not used   |
| 70                  | Not used   |
| 71                  | Not used   |
| 72                  | Failed to request data from motor controller for self test command |
| 73                  | Not used   |
| 74                  | Not used   |
| 75                  | Not used   |
| 76                  | Not used   |
| 77                  | Not used   |
| 78                  | Not used   |
| 79                  | Not used   |

| <b>Error Number</b> | <b>Description</b>   |
|---------------------|--|
| 80                  | Not used   |
| 81                  | Attention signal active at unexpected time                             |
| 82                  | SDA signal low at unexpected time                                      |
| 83                  | SCL signal low at unexpected time                                      |
| 84                  | I2C function reported incorrect state                                  |
| 85                  | I2C function returned unknown state                                    |
| 86                  | Not used   |
| 87                  | Not used   |
| 88                  | Write to receiver or motor controller failed                           |
| 89                  | Read to receiver or motor controller failed                            |
| 90                  | Not used   |
| 91                  | Not used   |
| 92                  | Attention line stayed active after a read                              |
| 93                  | Read to receiver or motor controller failed due to invalid data length |
| 94                  | MCM RAM test failed  |
| 95                  | A or E command issued but device not present                           |
| 96                  | Not used   |
| 97                  | O command issued but receiver not present                              |
| 98                  | Not used   |
| 99                  | A18 command to receiver 0 failed                                       |
| 100                 | A18 command to receiver 1 failed                                       |
| 101                 | Not used   |
| 102                 | Not used   |
| 103                 | Not used   |
| 104                 | Not used   |
| 105                 | Not used   |
| 106                 | Not used   |
| 107                 | Not used   |
| 108                 | Not used   |
| 109                 | Not used   |
| 110                 | PMB100 initialization write failed                                     |
| 111                 | PMB100 initialization read failed                                      |
| 112                 | PMB100 initialization read size incorrect                              |
| 113                 | Negative acknowledge during I2C communication                          |
| 114                 | Error reported by DUART port C   |
| 115                 | Error reported by DUART port D   |
| 116                 | Not used   |
| 117                 | Not used   |
| 118                 | Not used   |
| 119                 | Verification of data after flash write failed                          |
| 120                 | Not used   |



| <b>Error Number</b> | <b>Description</b>  |
|---------------------|---|
| 121                 | Not used  |
| 122                 | Verification of data after flash read failed                                |
| 123                 | Not used  |
| 124                 | Not used  |
| 125                 | Not used  |
| 126                 | Write during initialization of receiver or motor controller failed          |
| 127                 | ADC not idle before gathering housekeeping data                             |
| 128                 | Error buffer is full  |
| 129                 | Azimuth code space checksum incorrect                                       |
| 130                 | Elevation code space checksum incorrect                                     |
| 131                 | Timeout when sending to IRT   |
| 132                 | Timeout when receiving from IRT   |
| 133                 | Sent command does not match response for receiver or motor controller       |
| 134                 | Received command checksum invalid   |
| 135                 | Not used  |
| 136                 | Not used  |
| 137                 | Not used  |
| 138                 | Not used  |
| 139                 | Not used  |
| 140                 | Not used  |
| 141                 | Unexpected length for response  |
| 142                 | Unexpected response   |
| 143                 | G command data not ready when requested                                     |
| 144                 | Soft reset request failed   |
| 145                 | Not sufficient number of digits to left of decimal to print entire value    |
| 146                 | ADC in use during observation   |
| 147                 | DUART port C attempted to read 20 bytes out of 16 byte buffer               |
| 148                 | DUART port D attempted to read 20 bytes out of 16 byte buffer               |
| 149                 | Not used  |
| 150                 | Not used  |
| 151                 | Not used  |
| 152                 | Unknown synthesizer during observation command                              |
| 153                 | Invalid string passed to insert command                                     |
| 154                 | Invalid string length for insert command                                    |
| 155                 | Index for R command out of range  |
| 156                 | Index for receiver in R command out of range                                |
| 157                 | The last value in the MCM stack was written to                              |
| 158                 | The synthesizer lock signal changed during data collection                  |
| 159                 | The synthesizer lock signal was not set at the beginning of data collection |
| 160                 | A T command for a synthesizer was sent but no synthesizer was detected      |
| 161                 | A T command for a synthesizer was sent but no synthesizer was detected      |

| <b>Error Number</b> | <b>Description</b>  |
|---------------------|---|
| 162                 | The GPS pulse per second signal was active and then stopped being active for over 3 seconds   |
| 163                 | An interface clear command was issued while the Q command was in the INIT state               |
| 164                 | An interface clear command was issued while the Q command was in the RAIN_SAMPLING state      |
| 165                 | An interface clear command was issued while the Q command was in the PRESSURE state           |
| 166                 | An interface clear command was issued while the Q command was in the DIO state                |
| 167                 | An interface clear command was issued while the Q command was in the IRT state                |
| 168                 | An interface clear command was issued while the Q command was in the UNKNOWN state            |
| 169                 | The I2C communication had a timeout when waiting for a status byte                            |
| 170                 | The I2C communication had a timeout when waiting for the SCL line to go low                   |
| 171                 | The IRT responded with text instead of a valid temperature                                    |
| 172                 | During the I command, the IRT responded with some data but not a proper termination character |

**Table 1. MCM errors**

**RCV0 and RCV1 errors**

| <b>Error Number</b> | <b>Description</b>   |
|---------------------|--|
| 1                   | The real-time clock (RTC) string was not generated because a date value or time value was out of bounds (for example setting the seconds to 70). |
| 2                   | Creating a string from the RTC year failed.  |
| 3                   | Adding the delimiter to the RTC string failed.   |
| 4                   | Creating a string from the RTC month failed.   |
| 5                   | Creating a string from the RTC day failed.   |
| 6                   | Creating a string from the RTC hour failed.  |
| 7                   | Creating a string from the RTC minute failed.  |
| 8                   | Creating a string from the RTC second failed.  |
| 9                   | Not used.  |
| 10                  | Copying a string to the UART buffer failed.  |
| 11                  | Failed to get a byte out of the UART buffer.   |
| 12                  | A string was parsed for a 32 bit number but the value was larger than 32 bits (overflow).  |
| 13                  | A string was parsed as a floating point number and the decimal portion was invalid.  |
| 14                  | A float was being converted to a string but the requested decimal precision was too large.   |
| 15                  | A float was being converted to a string but the requested total precision was too large.   |
| 16                  | A float was being converted to a string but the buffer was too small to hold it.   |
| 17                  | A float was being converted to a string but the reversed string buffer was too small to hold it.   |
| 18                  | The function strcat() was called but the destination buffer had no NULL in it (no end of string).  |
| 19                  | The function strcat() did not complete successfully because the buffer size limit was reached.   |
| 20                  | The function PopToTermChar() failed because the output buffer size limit was reached.  |
| 21                  | The record number portion of a text string line of data was invalid.   |
| 22                  | The date/time portion of a text string line of data was invalid.   |
| 23                  | A command was received but the termination character was not found.  |
| 24                  | Invalid record type generated.   |
| 25                  | A configuration parameter was accessed with an invalid data type.  |
| 26                  | An attempt was made to print a configuration parameter with an invalid data type.  |
| 27                  | An attempt was made to lock the SPI bus for an invalid device.   |
| 28                  | A timeout occurred while transferring a byte on the SPI bus.   |
| 29                  | A timeout occurred while waiting for the SPI bus to be not busy.   |

| <b>Error Number</b> | <b>Description</b>   |
|---------------------|--|
| 30                  | The RTC configuration failed at startup.   |
| 31                  | The semaphore failed for locking the elapsed time variable in the housekeeping task.                               |
| 32                  | Not used.  |
| 33                  | The semaphore failed for locking the ADC variables in the housekeeping task.                                       |
| 34                  | The semaphore failed for locking the ADC variables in the I2C load buffer function in the command I2C task.        |
| 35                  | The semaphore failed for locking the ADC variables in the video task.  |
| 36                  | The semaphore failed for the SPI bus.  |
| 37                  | The semaphore failed for locking the elapsed time variable in the SendMsgFromTaskToComputerA() function.           |
| 38                  | The semaphore failed for locking the SendMsgFromTaskToComputerA() function.  |
| 39                  | The semaphore failed for locking the status variables in the video task.   |
| 40                  | The ADC input was unable to be converted from raw counts to a voltage or temperature.                              |
| 41                  | The ADC reading for the ND failed due to a timeout.  |
| 42                  | An invalid channel was specified for the ADC.  |
| 43                  | The control point was invalid.   |
| 44                  | A problem occurred with the thermal control such that the control loop was opened and the PWM set to 0 for safety. |
| 45                  | The H-bridge 5V output is not present.   |
| 46                  | The H-bridge is indicating a short circuit condition.  |
| 47                  | The H-bridge is indicating a temperature fault.  |
| 48                  | The H-bridge is indicating a low voltage on Vpeltier.  |
| 49                  | The H-bridge signals were computed incorrectly.  |
| 50                  | The semaphore failed for locking the status variables in the housekeeping task.                                    |
| 51                  | The 8051 indicated that data was ready before the trigger was sent.  |
| 52                  | The 8051 did not indicate integration complete within the timeout period.  |
| 53                  | Setting the attenuator for the observation failed.   |
| 54                  | The function call to load the Spinnaker synthesizer failed.  |
| 55                  | Setting the synthesizer to its minimum frequency at the end of an observation failed.                              |
| 56                  | The 8V supply was outside of the range of 7.4V to 8.6V.  |
| 57                  | An observation was performed and a video voltage was outside of the range of 0.5V to 2.4V.                         |
| 58                  | The temperature sensor T1 was outside of the range of -50C to +70C.  |
| 59                  | The temperature sensor T2 was outside of the range of -50C to +70C.  |
| 60                  | The temperature sensor T3 was outside of the range of -50C to +70C.  |

| <b>Error Number</b> | <b>Description</b>  |
|---------------------|---|
| 61                  | The temperature sensor T4 was outside of the range of -50C to +70C.   |
| 62                  | The 8051 responded with an unexpected value of "prime data."  |
| 63                  | The 8051 responded with an unexpected value of "reset."   |
| 64                  | The 8051 responded with an unexpected value of "no command."  |
| 65                  | The 8051 responded with an unexpected value of "2."   |
| 66                  | The 8051 responded with an unexpected value of "3."   |
| 67                  | The 8051 responded with an unexpected value of "4."   |
| 68                  | The 8051 reported an error indicating an invalid integration configuration.   |
| 69                  | The 8051 reported an error indicating data was read but no trigger was received.  |
| 70                  | The 8051 reported an error indicating data was read before integration completed.   |
| 71                  | The 8051 reported an error indicating the video voltage is railed low.  |
| 72                  | The 8051 bus is stuck high or the device is in reset.   |
| 73                  | The 8051 bus is stuck low.  |
| 74                  | The 8051 data on the SPI bus is all the same but not high or low.   |
| 75                  | The 8051 related error is unknown.  |
| 76                  | Priming the 8051 for integration after a reset failed.  |
| 77                  | Priming the 8051 for integration failed.  |
| 78                  | The frequency sent to the synthesizer was invalid. Valid frequencies are in the ranges of 11000-MHz to 15300-MHz or 22000-MHz to 30600-MHz or 50800-MHz to 61200-MHz inclusive. |
| 79                  | Not used.   |
| 80                  | Not used.   |
| 81                  | Not used.   |
| 82                  | The BBP failed to generate a response for the MCM.  |
| 83                  | Message on I2C was larger than the transfer buffer.   |
| 84                  | Not used.   |
| 85                  | Not used.   |
| 86                  | Not used.   |
| 87                  | Not used.   |
| 88                  | The total size of the configuration parameters is too large for one page of Flash.  |
| 89                  | The total size of the configuration parameters is not divisible by 4.   |
| 90                  | The configuration parameters were read from flash but were determined to be invalid (based on the CRC). This is typical for a newly programmed board.                           |
| 91                  | The configuration parameters in Flash are for a different version than what the present firmware supports.  |
| 92                  | The FLASH_ErasePage() function failed.  |
| 93                  | The FLASH_ProgramWord() function failed.  |

| <b>Error Number</b> | <b>Description</b>   |
|---------------------|--|
| 94                  | Readback of the programmed word failed.  |
| 95                  | The FLASH_ProgramWord() function failed for writing the version.   |
| 96                  | Readback of the programmed version failed.   |
| 97                  | The FLASH_ProgramWord() function failed for writing the CRC.   |
| 98                  | Readback of the programmed CRC failed.   |
| 99                  | The 8051 reported an error indicating the command byte was not in the right byte location.                   |
| 100                 | The PR-series tried to divide by zero when computing brightness temperatures.                                |
| 101                 | The PR-series had alpha set to zero when computing brightness temperatures.                                  |
| 102                 | The 8051 data is incorrectly being parsed for error codes.   |
| 103                 | The video state sequence had an undefined state other than the normal antenna, load, ND off/on combinations. |
| 104                 | The housekeeping task was called by the ADC data had not been updated.                                       |

**Table 2. RCV0 and RCV1 errors**

### Elevation and Azimuth Controller Errors

These errors are bit fields. The number reported is hexadecimal.

| Elevation |  |
|-----------|--|
| Sum       | Error Condition                          |
| 1         | RAM ERROR                                |
| 2         | TILT ERROR                               |
| 3         | RAM ERROR and TILT ERROR                 |
| 4         | HOME NOT FOUND                           |
| 5         | RAM ERROR and HOME NOT FOUND             |
| 6         | TILT ERROR and HOME NOT FOUND            |
| 7         | RAM ERROR, TILT ERROR and HOME NOT FOUND |

**Table C-3. Elevation error codes**

| Azimuth |   |
|---------|---|
| Sum     | Error Condition   |
| 1       | RAM ERROR   |
| 4       | HOME NOT FOUND  |
| 5       | RAM ERROR and HOME NOT FOUND                              |
| 8       | CW LIMIT HIT  |
| 9       | RAM ERROR and CW LIMIT HIT                                |
| C       | HOME NOT FOUND and CW LIMIT HIT                           |
| D       | RAM ERROR, HOME NOT FOUND and CW LIMIT HIT                |
| 10      | CCW LIMIT HIT   |
| 11      | RAM ERROR and CCW LIMIT HIT                               |
| 14      | HOME NOT FOUND and CCW LIMIT HIT                          |
| 15      | RAM ERROR, HOME NOT FOUND and CCW LIMIT HIT               |
| 18      | CW LIMIT HIT and CCW LIMIT HIT                            |
| 19      | RAM ERROR, CW LIMIT HIT and CCW LIMIT HIT                 |
| 1C      | HOMENOT FOUND, CW LIMIT HIT and CCW LIMIT HIT             |
| 1D      | RAM ERROR, HOME NOT FOUND, CW LIMIT HIT and CCW LIMIT HIT |

**Table C-4. Azimuth error codes**

**MP.exe v6.xx error messages**

| <b>Error Message</b>                             | <b>Notes</b>   |
|--|--|
| GPS data missing in new_gps                      | These gps errors are only for version > 6.08             |
| Serial timeout in new_gps                        |  |
| Error reading GPS data                           |  |
| V6.xx requires MCM >=1.35!                       |  |
| Serial timeout in getserial                      |  |
| 5 serial timeouts in getserial - resetting MCM   |  |
| MCM did not respond to interfaceclear            | interface clear command was added in v6.07               |
| Serial timeout in interfaceclear                 |  |
| 5 serial timeouts in interfaceclear - Hard reset |  |
| MCM in i2c - wait 30 seconds                     | MCM returned '&' in response to interface clear          |
| Spontaneous MCM re-boot detected                 | added in v6.09   |
| hcmd retry                                       | H command gets housekeeping data from MCM                |
| hcmd retry, bad value                            |  |
| ptcmd retry                                      | Pn is pass-through command to device n                   |
| rcmd retry                                       | R command reads a single channel (not used much anymore) |
| rcmd retry, bad value                            |  |
| icmd retry                                       | I command is initialize (MCM)                            |
| ccmd retry                                       | C command is configure timing parameters                 |
| qcmd retry                                       | Q command is surface met                                 |
| fcmd retry                                       | F command gets errors from MCM                           |
| fcmd fail  |  |
| tcmd retry                                       | T command sets synth type                                |
| jcmand retry                                     | J command resets i2c bus                                 |
| dcmd retry                                       | D command controls blower speed                          |
| ecmd retry                                       | E command is elevation move                              |
| acmd retry                                       | A command is azimuth move                                |
| acmd fail  |  |
| Az Drive hit limit switch                        |  |
| Unable to recover from az limit switch hit       |  |
| RS-422 time out in readbuf                       |  |
| RS-422 time out in receive                       |  |
| RS-422 time out in receive                       |  |
| RS-422 time out in readbuf                       |  |
| o8cmd error                                      | o8 errors - from obs,trcvcal,tip21 commands              |
| synth lock error                                 | synth reported un-locked on 1 or more frequencies        |
| Read error in o8cmd                              |  |
| Serial timeout in o8cmd                          |  |
| error in newplot                                 | Legacy graphics errors                                   |
| error in addtrace                                |  |



| <b>Error Message</b>   | <b>Notes</b>   |
|--|--|
| error in autoscale   |  |
| error in autoscale   |  |
| error in autoscale   |  |
| error in graphics mode: fonts not found  |  |
| error in graphicsmode: could not set font  |  |
| error in graphics mode: could not set font   |  |
| error in display plot: could not set font  |  |
| error in graphics mode: could not set font   |  |
| error in symbol: could not set font  |  |
| error in symbol: could not set font  |  |
| error in disptime: could not set font  |  |
| error in disptime: could not set font  |  |
| error in disptime: could not set font  |  |
| error in menu: could not set font  |  |
| error in menu: could not set font  |  |
| menu: could not set font in put_text   |  |
| error in menu: could not set font  |  |
| menu: could not set font in put_text   |  |
| ERROR, can not open the MP.CFG file  | errors in reading mp.cfg file                        |
| Could not find the MP TYPE: line<br>in the MP.CFG file. ShutDown.                      |  |
| Could not find the TIP CONFIGURATION:<br>line<br>in the MP.CFG file. ShutDown.         |  |
| ERROR reading TIP data from MP.CFG   |  |
| Could not find BLOWER SETTINGS: line<br>in the MP.CFG file. ShutDown.                  |  |
| ERROR reading BLOWER data from<br>MP.CFG   |  |
| Could not find the CHANNEL<br>CALIBRATION BLOCK: line<br>in the MP.CFG file. ShutDown. |  |
| Too many frequencies for microwave profiler  |  |
| Could not find the COEF: line<br>in the MP.CFG file. ShutDown.                         |  |
| End of MP.CFG file!  |  |
| ERROR, can not open the MP.CFG file  |  |
| Could not find the MP TYPE: line<br>in the MP.CFG file. ShutDown.                      |  |
| could not open the .prc file   | prc file errors                                      |
| runproc: error, non digit, non delim at end  |  |
| Hard-reset!  | Hard reset errors - for non-responsiveness of<br>MCM |
| HR retry   |  |

| <b>Error Message</b>                        | <b>Notes</b>   |
|---|--|
| Could not open serial port for mp. Aborting | serial port does not exist or is locked by another program |
|   |  |
| DlySec called with too big delay - STOP     |  |
| DlySec called with minus value - STOP       |  |

**Table 5. MP.exe v6.xx error messages**

This page left intentionally blank.

## Appendix D: VizMet-B User's Guide

### General Information

VizMet-B is a browser-based control and display software for the Radiometrics MP-Series Microwave Profiling Radiometers (MP-3000A, MP-2500A, and MP-1500A). VizMet-B turns the radiometer Host Computer into a powerful web server, providing interactive access to the instrument from any remote computer connected by LAN or the Internet without installing any special software on the remote computer. VizMet-B uses Java technology to enable any modern Windows, Mac, UNIX, or LINUX computer to connect and display the Graphical Users Interface (GUI). Remote computers only require a browser (e.g., Chrome or Firefox) and Java. The VizMet-B color GUI simplifies and automates radiometer configuration, control calibration, and monitoring.

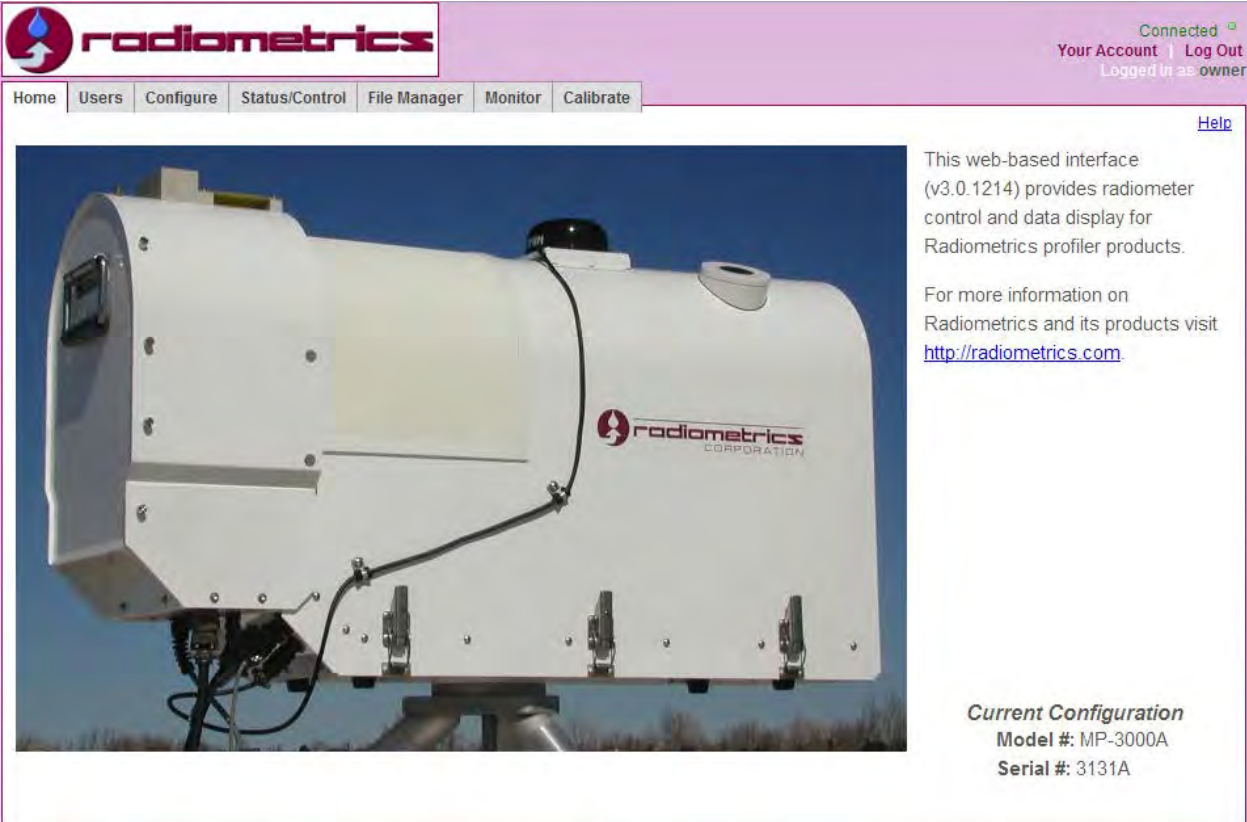

**radiometrics**

Connected   
Your Account | Log Out  
Logged in as owner

Home | Users | Configure | Status/Control | File Manager | Monitor | Calibrate

[Help](#)

This web-based interface (v3.0.1214) provides radiometer control and data display for Radiometrics profiler products.

For more information on Radiometrics and its products visit <http://radiometrics.com>.

**Current Configuration**  
Model #: MP-3000A  
Serial #: 3131A

**Figure D-1. Home page and login for radiometer**

Above is pictured radiometer model MP-3000A, serial # 3131A. To login, click on the “Log In” text in the upper right corner, and then enter **User Name** and **Password**.

## Starting VizMet-B

If VizMet-B has been installed on the Control Computer, it will start automatically when the computer is started. To log in from the Control Computer, open a browser window with “local host” as the address. If the Control Computer is connected to the Internet and is assigned a fixed IP address, VizMet-B can be operated via Internet from a remote computer by entering the fixed IP address of the Control Computer in an Internet browser, as shown in Figure D-1.

### Single User GUI

A single user GUI method for radiometer operation is described in the **Radiometrics Profiler Operator’s Manual**. If the user wants to control the operating code directly using the single user GUI (and not using the optional VizMet-B software), the VizMet-B server and certain Windows scheduled tasks must be disabled on the Control Computer.

To disable VizMet-B and modify settings, login under the username **laptop**.

- On the Control Computer, navigate:

**Start > All Programs > Radiometrics > Stop Server**

- Also on the Control Computer, navigate:

**Start > Control Panel > Scheduled Tasks > right-click appserver > Properties > Unclick Enable box**

- Repeat the process for the additional **Scheduled Tasks**:
  - forceful\_stop
  - graceful\_stop
  - oppserver
  - restarter

To re-enable VizMet-B and modify settings, log in under the username **laptop**.

- On the Control Computer, navigate:

**Start > All Programs > Radiometrics > Stop Server**

- Also on the Control Computer, navigate:

**Start > Control Panel > Scheduled Tasks > right-click appserver > Properties > Click Enable box**

- Enable all of the **Scheduled Tasks** mentioned above.

## Users (Accounts and Privileges) Tab

radiometrics

Connected <sup>□</sup>  
Your Account | Log Out  
Logged in as owner

Home Users **Configure** Status/Control File Manager Monitor Calibrate

Help

### User Accounts

| Login    | Email                 | Role     | Created             | Actions                                     |
|----------|-----------------------|----------|---------------------|---|
| owner    | owner@nowhere.com     | Owner    | 04/25/2006 01:53 PM | <a href="#">Edit</a> <a href="#">Delete</a> |
| operator | operator@nowhere.com  | Operator | 04/25/2006 02:00 PM | <a href="#">Edit</a> <a href="#">Delete</a> |
| copeland | copeland@starinst.org | Operator | 11/30/2011 09:02 PM | <a href="#">Edit</a> <a href="#">Delete</a> |

[Create](#) a new account.

**Figure D-2. Users tab**

The Owner controls accounts and privileges, via the Users tab. A User with full privileges (Owner) can manage users and access all of the tabs in Figure D-2. A User with limited privileges (Operator) can access only the **Home**, **File Manager** and **Monitor** tabs.

## Configure Tab

radiometrics

Connected <sup>□</sup>  
Your Account | Log Out  
Logged in as owner

Home Users **Configure** Status/Control File Manager Monitor Calibrate

Help

### Configuration Files

| Name/Modified   | Actions                                       |
|---|---|
| Operational Configuration(mp.cfg):<br>Modified: 2012/01/08 15:37:28 | <a href="#">View</a> <a href="#">Edit</a>     |
| Backup Configurations:<br><br>2011-12-20_16-24-02.cfg               | <a href="#">View</a> <a href="#">Transfer</a> |

**Figure D-3. The Configure tab**

The radiometer mp.cfg file can be viewed, edited and transferred on this tab. The mp.cfg file determines a variety of radiometer calibration and configuration parameters. Additional information on the mp.cfg file can be found in the **Radiometrics Profiler Operator's Manual**.

## Status/Control Tab

**radiometrics**

Home Users Configure **Status/Control** File Manager Monitor Calibrate

Connected  
Your Account | Log Out  
Logged in as owner

Help

### Procedure Control

You may replace the currently running procedure, put the radiometer into "Idle" mode, or stop the operational code completely using the controls below.

Procedure File:

### Radiometer Console Log

### Status

| Measurement      | Value                    |
|------------------|--------------------------|
| Time:            | 01/09/2012 20:43:13      |
| Output File(s):  | 2012-01-09_00-00-09      |
| Status:          | Stopped                  |
| Error Status:    | OK                       |
| Rcvr0 TkND:      | 323.163 K                |
| Rcvr1 TkND:      | 323.175 K                |
| TkBB:            | 299.383 K                |
| Tamb:            | 284.353 K                |
| RH:              | 31.9 %                   |
| Pressure:        | 843.8 mb                 |
| Tir:             | 196.120 K                |
| Rain:            | 0.144 V                  |
| LN2 Calibration: | 12/29/2011               |
| TIP Calibration: | 2012-01-05_22-26-31 Done |

**Figure D-4. That Status/Control tab**

The **Status/Control** tab allows the user (with owner privileges) to select procedure files that control the radiometer, as described in detail in the **Radiometrics Profiler Operator's Manual**. This tab also displays radiometer status, selected radiometer parameters and measurements, and recent errors (if any).

**Error Status** will have the Value **OK**, unless there have been errors. In case of errors, the line will indicate:

- a. device reporting the error
- b. number of errors
- c. error codes, as will fit on the line

So, the example message shown in Figure D-5 indicates:

- a. the Main Control Module (MCM)
- b. reported two errors (002)
- c. error codes 2 and 9

See **Appendix C: Error Messages for A-Series Radiometers, Version 6.xx Operating Code** for additional information on error messages.

| a.  | b.  | c.  |
|-----|-----|-----|
| MCM | 002 | 2 9 |

**Figure D-5. Sample error message**

**NOTE:**

In the event of an error, VizMet-B will continue to display an error code until the daily restart occurs, or until the procedure is stopped and restarted. These **Stop** and **Start** operations can take several minutes to complete.

In VizMet-B, navigate:

**Status/Control > Stop**

then...

**Status/Control > Start**



## File Manager Tab

The screenshot shows the File Manager interface. At the top, there is a navigation bar with the Radiometrics logo and user information: 'Connected', 'Your Account', 'Log Out', and 'Logged in as owner'. Below the navigation bar, there are tabs for 'Home', 'Users', 'Configure', 'Status/Control', 'File Manager' (selected), 'Monitor', and 'Calibrate'. A 'Help' link is visible in the top right corner.

The main content area displays a table of files with the following columns: 'x', 'Filename', 'Type', 'Modified', and 'Size'. The table contains 15 rows of files, including various data files (Level 0, 1, 2), configuration files (mp.cfg, tip.cfg), and health status files (healthstatus.csv).

Below the table, there are controls for file selection and actions:

- Select:
- With Selected:
- Select a file to upload:  No file chosen

**Figure D-6. The File Manager tab**

Use the **File Manager** to view or modify the contents of the operating directory. Files can be displayed by name, file type, date modified, or size. Click on a column header to sort files and subdirectories located in the operating folder. Use the **Filter** text box to list only the files specified by the filter. The character “\*” is a wild card character.

Controls are provided to download and delete files, and to browse for and upload files from other local computer directories. Any or all files can be downloaded without affecting normal operation. Double click on any file to open a copy on the local computer.

## Monitor Tab

This tab allows display of radiometer observation and retrieval time series. Use the **3D**, **Profiles**, and **2D Line** tabs to select the corresponding data display. And use the **Options and Health Status** tab to display Health Status.

### 3D Color

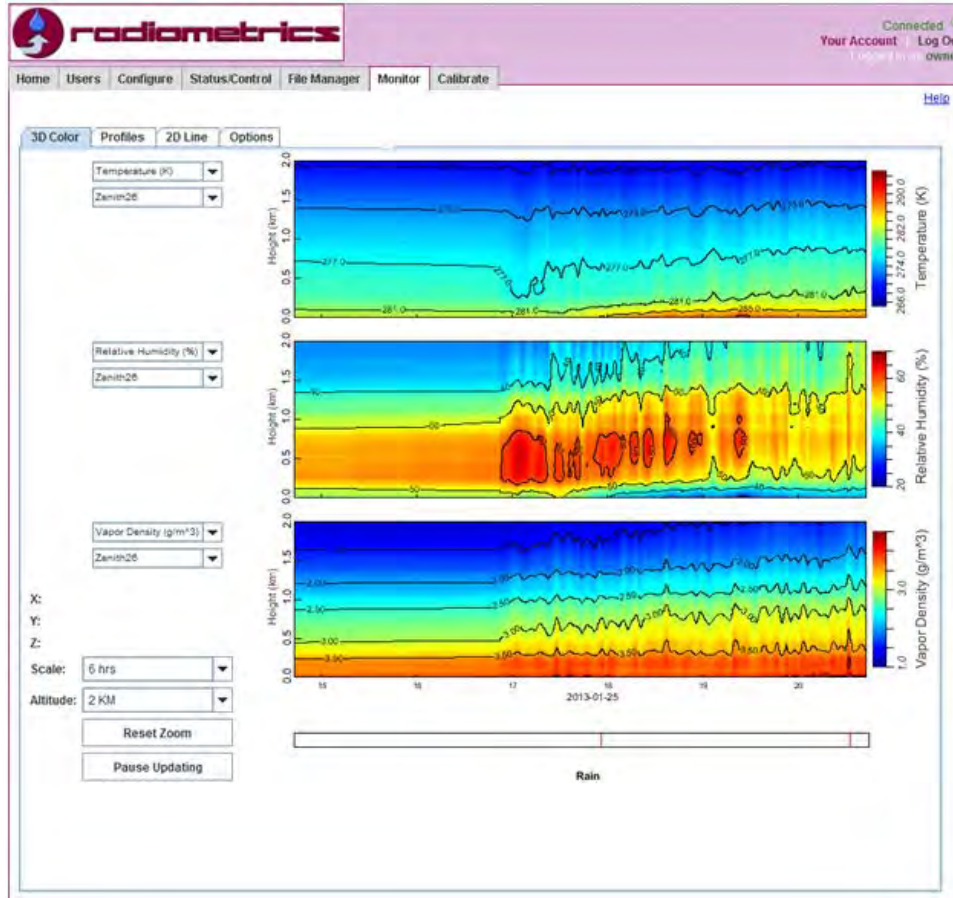

Figure D-7. The Monitor tab (3D Color tab selected)

The **3D Color** sub-tab provides color contours (selectable by pull-down menus) of

- retrieved temperature
- relative humidity
- vapor density
- liquid

The rain sense flag indicates when rain is present. It appears below the 3D plots.

Numerical coordinates (X, Y, and Z) display at the lower left (see **Figure D-7** and detail in **Figure D-8**) along with:

- **Scale** (time periods of 6, 12, 24, 48 and 72 hours)
- **Altitude**(altitudes of 1, 2, 5 and 10 kilometers)
- **Reset Zoom** to restore the default time scale
- **Pause (Resume) Updating** to control real time data display

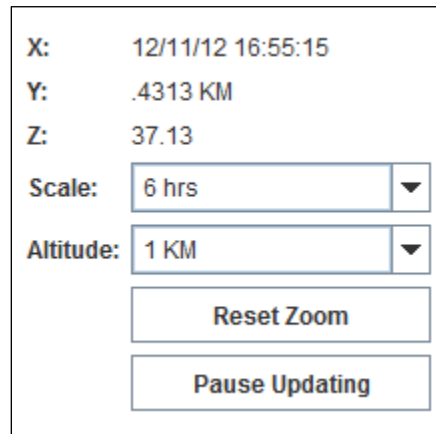

The screenshot shows a control panel with the following elements:

- X: 12/11/12 16:55:15
- Y: .4313 KM
- Z: 37.13
- Scale: 6 hrs (dropdown menu)
- Altitude: 1 KM (dropdown menu)
- Reset Zoom button
- Pause Updating button

**Figure D-8. Numerical coordinates and menus**

With click-and-zoom mouse capability, users can select and expand specific time scales and features on the contour plots.

## Profiles

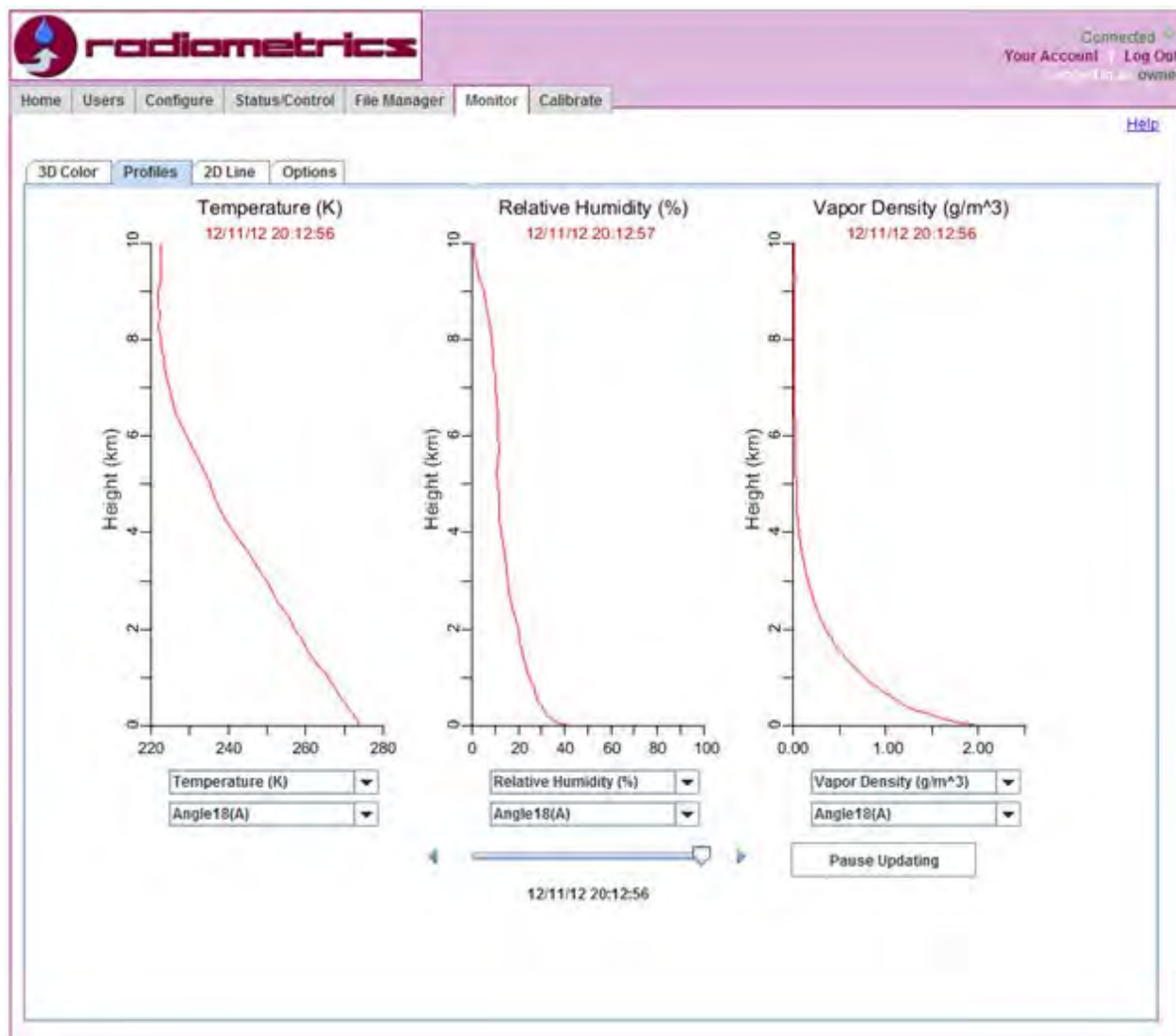

**Figure D-9. The Profiles tab**

Each plot has two pull-down menus below it.

Retrieval type is in the top pull-down menu:

- Temperature
- Relative humidity
- Vapor Density
- Liquid

Different angle scans (if available) are in the lower pull-down menu:

- Angle Scan18/26(A)
- Angle Scan18/26(N)
- Angle Scan18/26(S)
- Zenith26

Users can observe time evolution of retrieved profiles by clicking **Pause Updating** and adjusting the slider.

## 2D Line



**Figure D-10. The 2D Line tab**

The **2D Line** tab displays any radiometer time series measurements, with click-and-zoom mouse capability. Included in the drop-down menus are:

- surface temperature
- relative humidity
- integrated vapor and integrated liquid
- cloud base temperature
- cloud base height
- observed brightness temperatures from measured microwave channels

If the cursor is located within any of the plot boxes, the X and Y values at the cursor location are displayed at lower left. Time scales as well as observations at specific elevation and azimuth angles can be displayed.

## Calibrate Tab

This tab simplifies and automates liquid nitrogen (LN2) and tip calibration procedures described in detail in the **Radiometrics Profiler Operator's Manual**. Use the **Calibrate** tab to control LN2 calibration. It also allows TIP and LN2 calibration time series displays and click-and-zoom data selection and transfer. The **Select LN2 Calibration** and **Select Tip Calibration** buttons allow easy access to previous calibration files, if needed. More information on these files is available in the **Radiometrics Profiler Operator's Manual**.

### VizMet-B LN2 Calibration Instructions

1. Review the LN2 calibration instructions in **Appendix E**.
2. Referring to **Appendix E**, if an Azimuth positioner is installed, disconnect the Azimuth positioner cable.
3. Before starting the calibration procedure, first click on the **Status/Control** tab and click the **Stop** button to stop the current procedure. Wait until the Status value in the Status box indicates **Stopped**.
4. Don't start a new calibration within one hour of midnight UTC, as the Host Computer starts a new set of files at midnight.

Radiometrics recommends setting the Host Computer clock to UTC; if it is on local or other time, the LN2 calibration status on the **Status/Control** tab may not properly display the new calibration date.

5. Click on the **Calibrate** tab.
6. Place the Cryogenic Target on the radiometer, as described in **Appendix E**.
7. Click on the **Start LN2 Calibration** button. Note that if a procedure file is still running, the **Start LN2 Calibration** button will be grayed out and nonresponsive; stop the current procedure to enable the **Start LN2 Calibration** button.

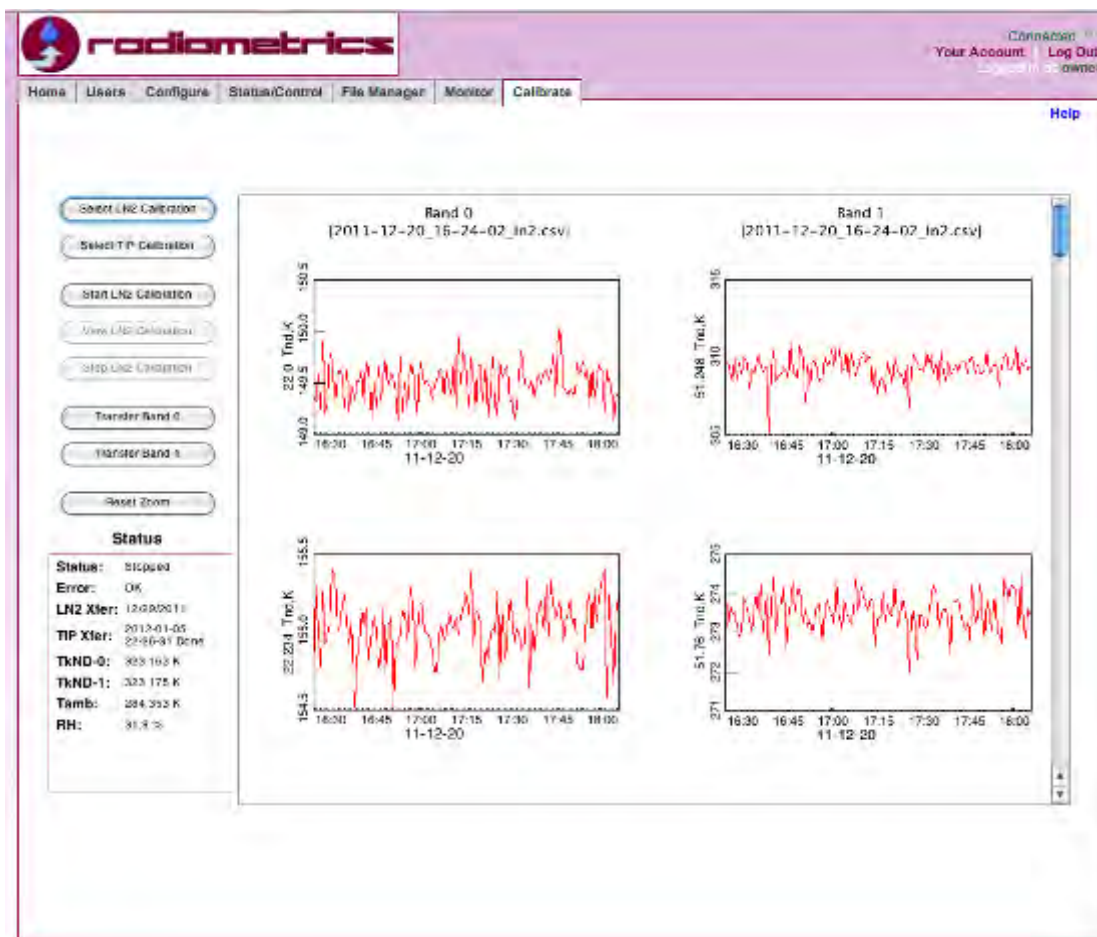

Figure D-11. The Calibrate tab

- As the calibration progresses, the ND temperatures will populate the **Band 0** (K band) and **Band 1** (V band) plots, as shown in **Figure D-11**.

The time series above shows Noise Diode (ND) temperatures in degrees K, as calibrated during a one-hour liquid nitrogen target observation. For a successful calibration, the time series should be stable within  $\pm 2$  K, with no slope, as shown in Figure D-11 and Figure D-12. An imaginary line representing the average ND temperature should be flat with no slope (see Figure D-12).

- After one hour of stable ND calibration data have been collected, click the Stop LN2 Calibration button. If necessary, a subset of the time series can be selected for transfer from K (**Band 0**) or V (**Band 1**) using click and zoom. VizMet-B will then use only the timeframe selected for each band for the calibration calculations.
- Click the **Transfer Band 0** and **Transfer Band 1** buttons to automatically create a new mp.cfg file including the new calibration. This also automatically saves the old

mp.cfg file with a date and time stamp. When transferring **Band 0** and **Band 1**, VizMet-B does not provide a visual indication that the transfer is completed; however, the transfer is completed immediately. When the new data is transferred, VizMet-B creates a new mp.cfg file that has the new calibration data; the original mp.cfg is renamed to **yyyy-mm-dd\_hh-mm-ss.cfg**, where...

- a. **yyyy-mm-dd** is the date, and
- b. **hh-mm-ss** is the time that the new LN2 calibration was transferred.

More information on the mp.cfg file is included in the **Radiometrics Profiler Operator's Manual**.

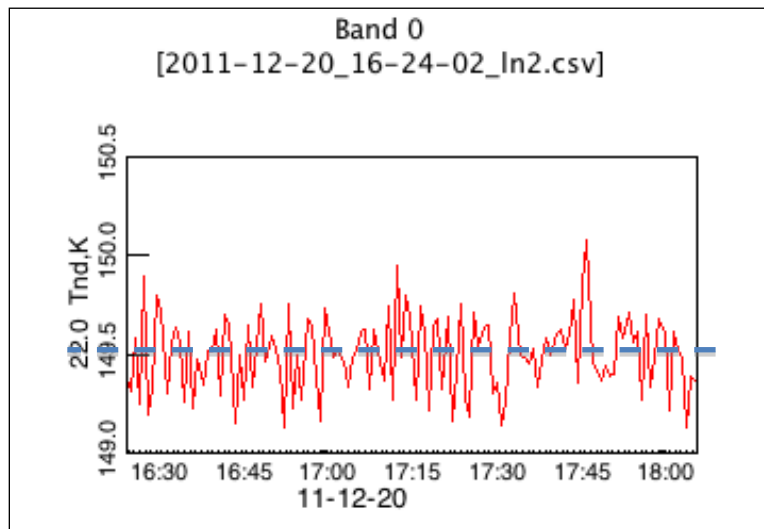

**Figure D-12. Imaginary line “averaged” through noise diode temperature**

### Returning the radiometer to normal operation

1. Referring to **Appendix E**, remove the cryogenic target and Saddle; if an Azimuth positioner is installed, reconnect the Azimuth positioner cable.
2. Return to the VizMet-B **Control/Status** tab and restart the desired procedure. The new LN2 calibration date will appear in the **Status** box.
3. Perform a quick system health check by opening the current mp.cfg and the newly created back-up yyyy-mm-dd\_hh-mm-ss.cfg and comparing the calibration data in both files. Observe the superimposed mp.cfg files in Figure D-13, below.
  - a. Use **Notepad** or other ASCII text editor to open the files.

**NOTE:** do NOT use Word or WordPad or other word processor program, as these programs will insert additional ASCII characters.



- b. The last (right-most) number displayed for every channel in the calibration block is the noise diode (ND) temperature for that channel. The old and new value for most channels should be within +/- 0.5 K; differences greater than 1K should be reported to Radiometrics for analysis.
- c. If the old and new calibration data are identical, then the calibration data was not properly transferred. Return to the VizMet-B **Calibration** tab, click the **Select LN2 Calibration** button to select and view the most current calibration data, and follow the instructions above to transfer the calibration data.

The image shows a software window with two overlapping text files. The top file is a CSV file with columns for channel number, frequency, and various parameters. The bottom file is an mp.cfg file with similar data for 30 channels. The data includes channel numbers (31-45), frequencies (e.g., 107711.2E+2), and various numerical values representing calibration parameters and noise diode temperatures.

Figure D-13. Calibration data: mp.cfg file superimposed over a CSV file

4. After calibration is completed, click the **Status/Control** tab, select a procedure and click the **Start** button to resume radiometer observations.

### Operating the Radiometer from the laptop computer

1. In VizMet-B (running on the host computer), navigate:

**Status/Control tab > Stop**

VizMet-B will indicate “Stopping...” in the status box. Wait for the status to indicate “Stopped.”

2. Connect to the auxiliary port of the radiometer another computer, with the following installed on it:
  - VizMet-B
  - RS-422 USB pod driver
3. On the new computer, run a browser to “localhost” and log on to VizMet-B.
4. Perform necessary tasks.
5. When finished performing tasks, navigate:

**Status/Control tab > Stop**

Wait for the status to indicate “Stopped.”

6. Disconnect the cable from the auxiliary port on the radiometer.
7. Back on the host computer, in VizMet-B, resume normal operation by navigating:

**Status/Control tab > Start**

For more information, contact Radiometrics Customer Service at

Radiometrics Corporation  
4909 Nautilus Court North, Suite 110  
Boulder, CO 80301 USA  
Phone: +1-303-449-9192  
Fax: +1-303-786-9343  
email: [support@radiometrics.com](mailto:support@radiometrics.com)  
website: <http://www.radiometrics.com>

## Uninstalling VizMet-B 3.0 from the Windows 7 Environment<sup>2</sup> (or later)

### General Information

Should VizMet-B begin delivering faulty information, the most effective course of action is to uninstall it and then re-install it.

### Overview

The following information describes how to properly uninstall VizMet-B 3.1.1217 from a Windows 7 (“Win 7”) control computer for an MP-xx00A series radiometer. The VizMet-B uninstall will remove several small applications on the destination computer. VizMet-B 3.1.1217 utilizes Java, Ruby, Ruby on Rails, and SQLite3 to operate the Web server, its maintenance scripts and graphic display. These applications will all be uninstalled, so that may be configured in the re-install to run in the c:\localhost directory.

### Preparation

Backup the operational directory. Navigate:

**c:\sites\radiometrics-vizmetb\operational**

Copy the operational folder someplace safe, such as another location/drive, so you can use the files after the re-install.

### Procedure

1. Navigate:

**Start > Control Panel > Programs and Features > VizMetB**

2. Right-click VizMetB, and select **Uninstall**.

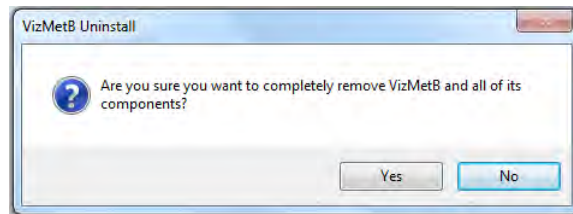

**Figure D-14. Uninstalling the VizMet-B program**

3. Click **Yes**.

---

<sup>2</sup> The same concepts within these instructions also apply to the Windows 8 environment. Contact your IT personnel to navigate, as necessary.

4. Navigate:

**Start > Control Panel > Programs and Features > Java 7 Update 9**

5. Right-click Java 7 Update 9, and select **Uninstall**.

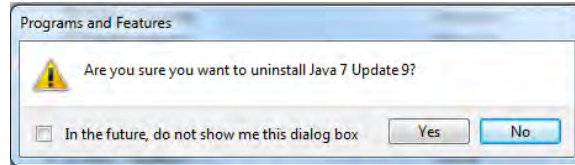
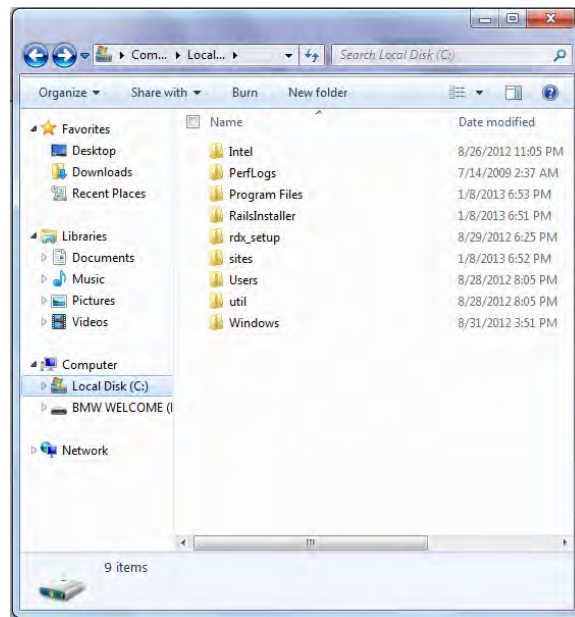

**Figure D-15. Uninstalling the Java 7 Update 9 program**

6. Click **Yes**.

7. Navigate:

**Start > Computer > Local Disk**



**Figure D-16. Navigating to the local disk**

8. Right-click the RailsInstaller folder and select **Delete**.

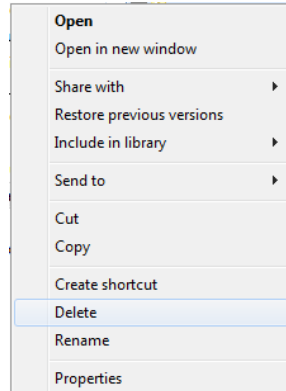

**Figure D-17. Selecting the Delete option**

A screen checks your decision.

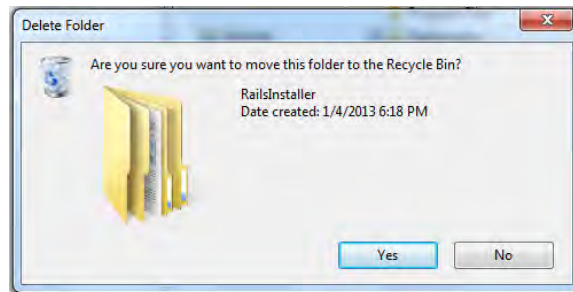

**Figure D-18. Deciding to delete the RailsInstaller folder**

9. Click **Yes**.

10. Still in the Local Disk, right-click the sites folder.

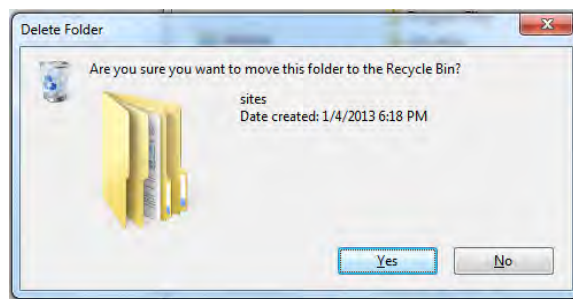

**Figure D-19. Deciding to delete the sites folder**

11. Click **Yes**.

12. Restart the computer.

13. Proceed with the following instructions for installing VizMet-B into a Windows 7 environment.

## VizMet-B 3.0 Installation for Windows 7 Environment<sup>3</sup> (or later)

### General Information

VizMet-B is an optional browser-based control and display software for the Radiometrics MP-Series Microwave Profiling Radiometers (MP-3000A, MP-2500A, and MP-1500A). VizMet-B turns the radiometer Control Computer into a powerful web server, providing interactive access to the instrument from any remote computer connected by LAN or the Internet without installing any special software on the remote computer. VizMet-B uses Java technology to enable any modern Windows, Mac, UNIX, or LINUX computer to connect (via LAN or Internet) to the radiometer control computer and display the Graphical User Interface (GUI). Remote computers only require a browser (e.g., Chrome or Firefox) and Java. The VizMet-B color GUI simplifies and automates radiometer configuration, control calibration and monitoring.

### Overview

The following information describes how to properly install VizMet-B 3.0 on a Windows 7 (“Win 7”) control computer for an MP-xx00A series radiometer. The VizMet-B 3.0 application installer will install several small applications on the destination computer. These applications are required for the MP-3000A radiometer normal operation.

VizMet-B 3.0 utilizes Java, Ruby, Ruby on Rails, and SQLite3 to operate the Web server, its maintenance scripts and graphic display. These applications will all be installed and configured to run in the c:\localhost directory.

Customers will receive the VizMet-B installers via one of two methods:

- A mailed CD
- An Internet connection, such as Dropbox

The installer should review the entire instruction set **before** attempting to complete the procedure. Contact Radiometrics Customer Support with any questions regarding this procedure at:

phone: +1-303-449-9192 / email: [support@radiometrics.com](mailto:support@radiometrics.com)

---

<sup>3</sup> The same concepts within these instructions also apply to the Windows 8 environment. Contact your IT personnel to navigate, as necessary.

**Special Requirements:**

- Windows System 7
- 500 Mb of memory
- Internet browser, such as Chrome or Firefox (not Internet Explorer)

**Preparation**

1. User requires Administrator rights (name and password) on the control computer.
2. Users need to know whether their computer is an Intel or AMD device.
3. Users must reset their User Account Control settings. Navigate:

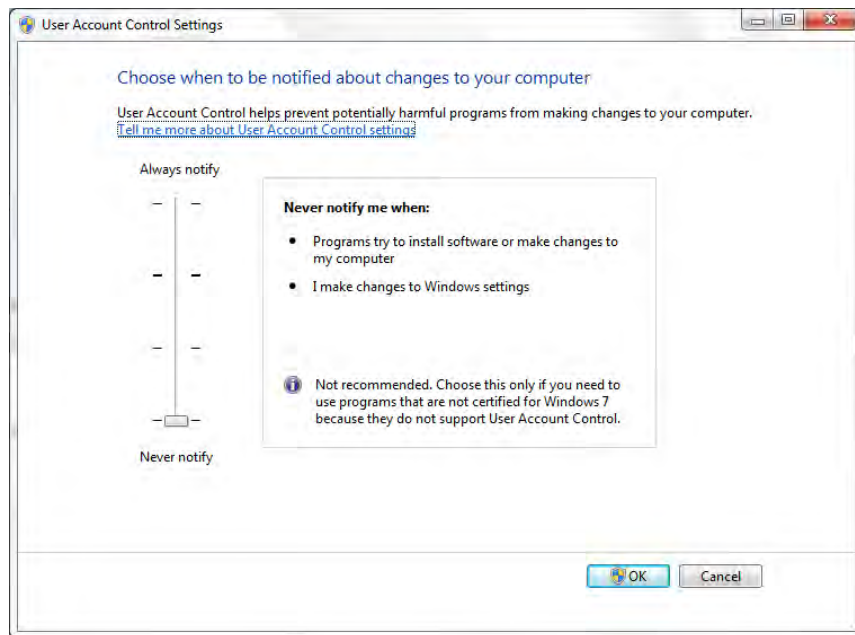
**Control Panel > User Account > Change User Account Control settings****Figure D-20. Resetting UAC notification setting**

There, users will change the notification setting to **Never notify**.

4. Users must change their computer's sleep settings to **Never**. Navigate:

**Control Panel > Hardware and Sound > Power Options > Change when the computer sleeps**

There, users can edit plan settings.

**Procedure**

1. Determine which version of VizMet-B to use:
  - vizmet-b-i586 (Intel)
  - vizmet-b-x64 (AMD)

2. **Run as Administrator.** Right-click the VizMet-B icon to select **Run as Administrator**.
3. Click **Yes** when asked,  
  
“Do you want this program to make modifications to your computer?”
4. Ensure that the setup wizard specifies version 3.1.1217 (or later) and click **Next**.

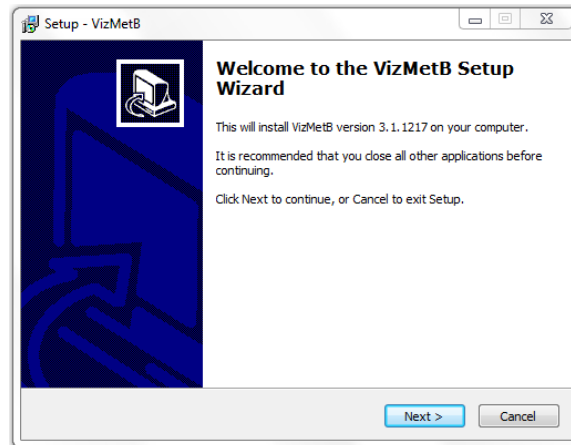

**Figure D-21. Setup wizard welcome screen**

5. Click **Next** to specify the web server port of **8080** (recommended default).

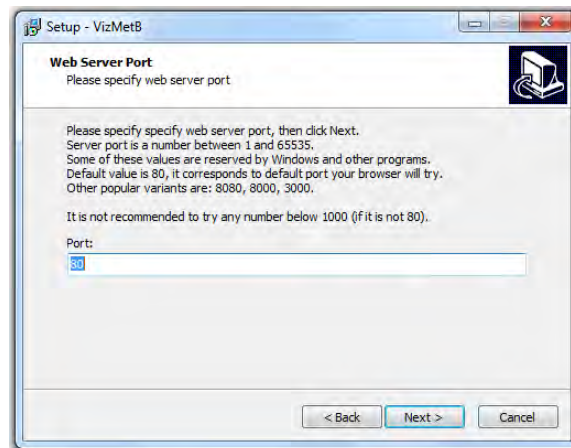

**Figure D-22. Web server port**

6. Click **Browse** to select where to install the program, or use the default setting (strongly recommended).



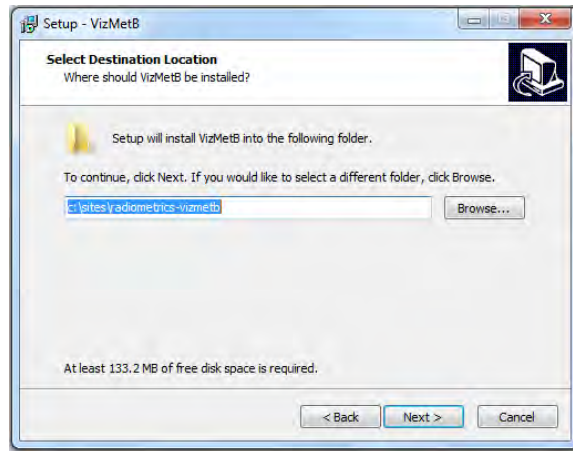

**Figure D-23. Setup install location**

7. Click **Next**.
8. Click **Browse** to select where to install the shortcuts, or use the default setting (strongly recommended).

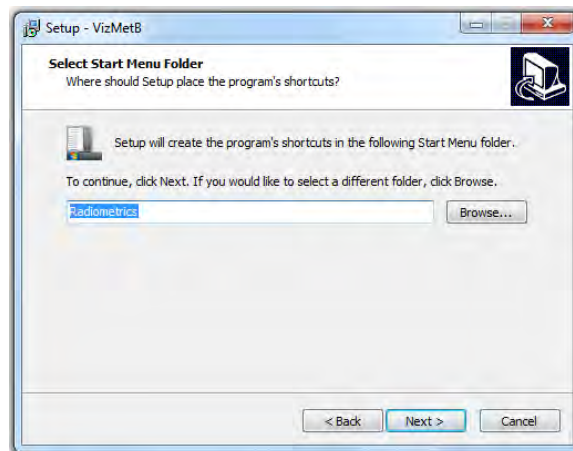

**Figure D-24. Setup shortcuts location**

9. Click **Next**.
10. Review the settings and click **Install**.

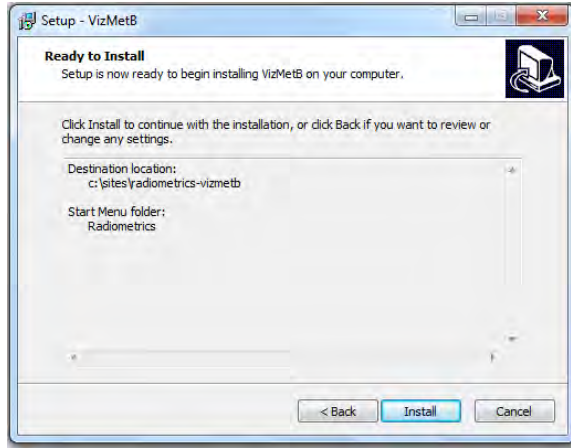

**Figure D-25. Setup ready to install**

The VizMet-B files install:

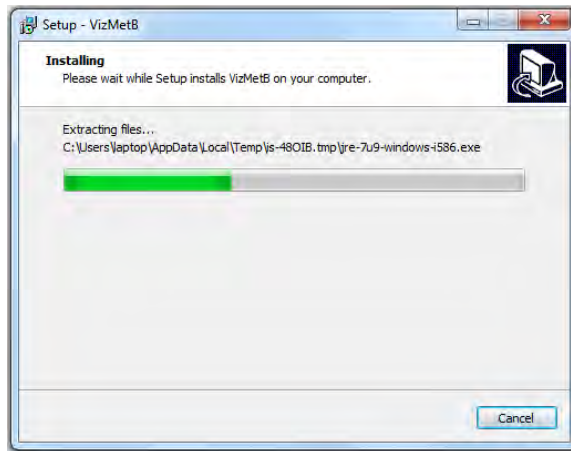

**Figure D-26. Installing**

When complete, the **RailsInstaller** setup starts.



**Figure D-27. RailsInstaller setup**

11. Click **Next**.

12. Review and accept the license agreement, and click **Next**.

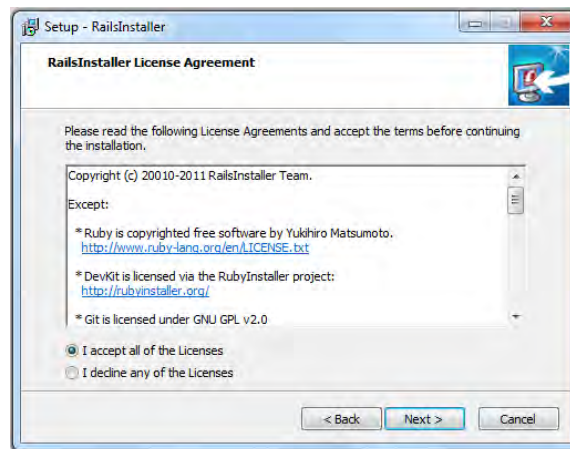

**Figure D-28. License agreement**

13. Click **Browse** to select the installation destination, or use the default setting (strongly recommended).

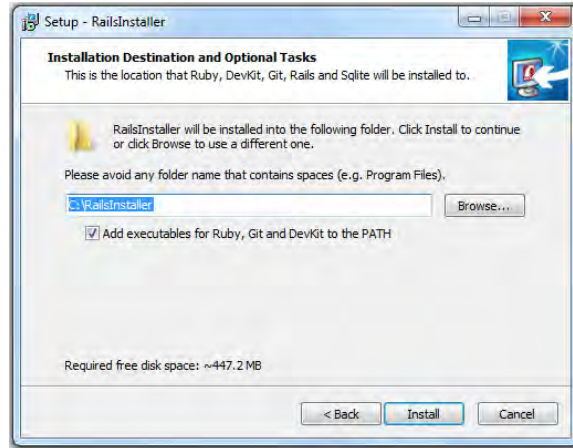

**Figure D-29. Installation location**

14. Click **Install**.

The files will install for a few minutes.

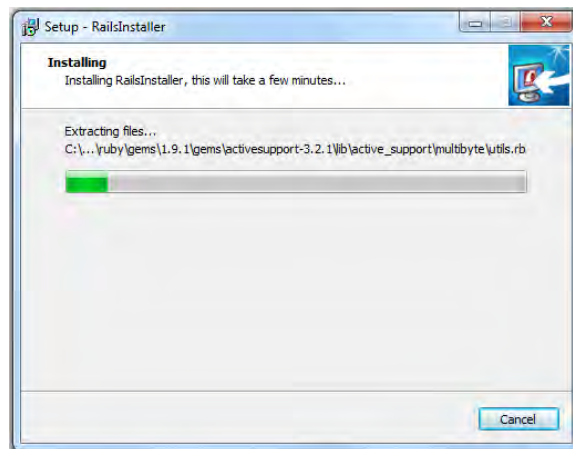

**Figure D-30. Files installing**

When installation is complete, a RailsInstaller window appears.

15. Leave the configuration box checked, and click **Finish** to complete the setup wizard.



Figure D-31. Completing the setup

A command prompt window appears, followed by an empty shell window:

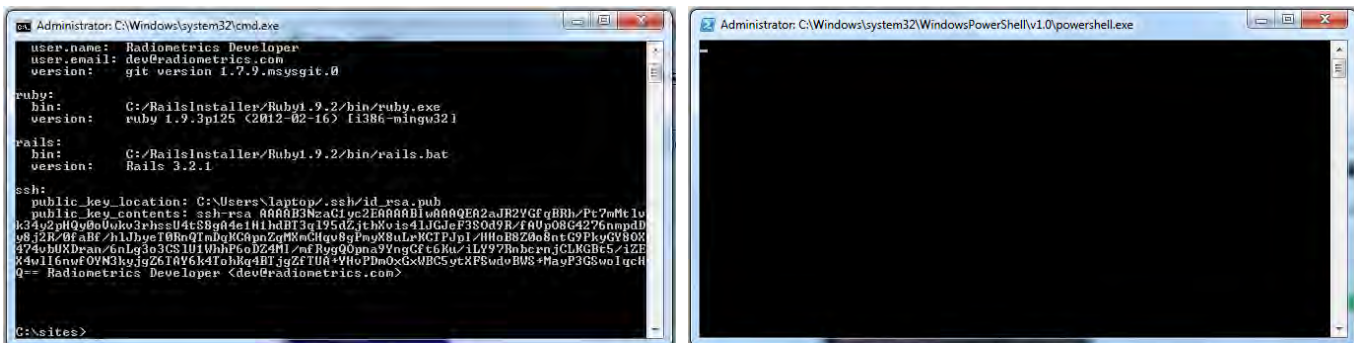

Figure D-32. Command prompts (left) and disappearing shell window (right)

16. Allow the empty shell window to disappear by itself.

17. In the remaining command prompt, type **exit** and press **Enter**.

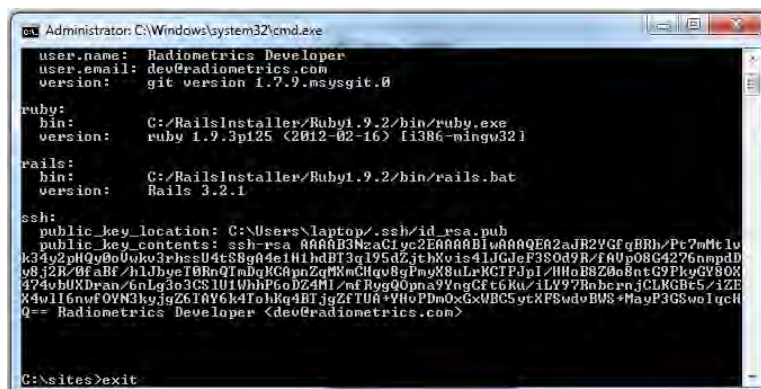
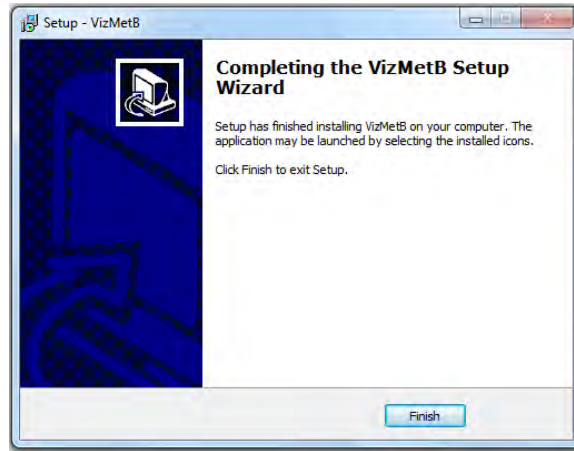

Figure D-33. Typing 'exit' in the command prompt

The VizMet-B set completion window appears.



**Figure D-34. Notice of completion**

18. Click **Finish**.

A prompt window asks if you need Java.

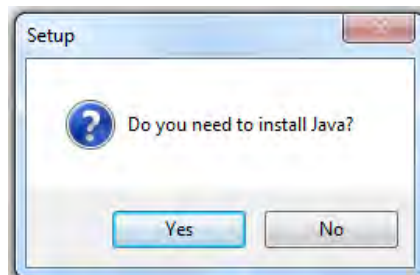

**Figure D-35. Starting Java setup**

A set of Java files is contained within the VizMet-B installation, but for security purposes, it is recommended that you use the most up-to-date version of Java. If you cannot access up-to-date Java, skip to Step 22 below. Otherwise, you will have the opportunity to install an up-to-date version of Java when you run VizMet-B, therefore:

19. Click **No**.

20. Click **Close**.

21. Restart the computer.

The installation should now be complete. You are now able to put data and configuration files back into the radiometer operational folder, and perform one last reboot.

The system should come up, be ready, and be connected to the radiometer. To test this, open a web browser and, if not already showing, direct it to: <http://localhost>.

**If you cannot access an up-to-date version of Java, use the Java provided in the VizMet-B installation.**

22. Click **Yes**.

A prompt window tells you what version of Java it will install.

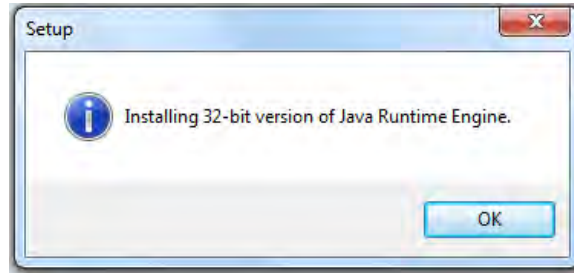

**Figure D-36. Notice of Java version**

23. Click **OK**.

The Java installer setup appears.



**Figure D-37. Java setup**

24. Click **Install**.

The installation status window appears.



**Figure D-38. Java installation status**

After Java finishes installing, a notification of success appears.



**Figure D-39. Success notification**

25. Click **Close**.

26. Restart the computer.

## Summary

The installation should now be complete. You are now able to put data and configuration files back into the radiometer operational folder, and perform one last reboot.

The system should come up, be ready, and be connected to the radiometer. To test this, open a web browser and, if not already showing, direct it to: <http://localhost>.



For more information, direct enquiries to Radiometrics Customer Support at

Radiometrics Corporation  
4909 Nautilus Court North, Suite 110  
Boulder, CO 80301 USA  
Phone: +1-303-449-9192  
Fax: +1-303-786-9343  
email: [support@radiometrics.com](mailto:support@radiometrics.com)  
website: <http://www.radiometrics.com>

## Appendix E: Radiometer Calibrations

### *E.1 Calibrating Radiometrics MP-xx00A Radiometers with Liquid Nitrogen (LN2)*

#### **Safety Considerations**

Liquid Nitrogen (LN2) is extremely cold. It can cause severe burns to the human body, particularly to the skin and eyes. To avoid the risk of a cryogenic burn, LN2 should always be handled with care and respect. Handlers should wear appropriate protective clothing, gloves and goggles.

Handlers must also take precautions to ensure adequate ventilation. The gas is not toxic, but at high concentrations, it reduces the available oxygen in the air.

Disconnect the Azimuth drive (if installed) prior to placing the Cryogenic Target on the radiometer to avoid potential LN2 spills resulting from the azimuth drive moving.

To calibrate the profiling radiometer, use two “microwave targets” (microwave loads) of known temperature:

- A built-in ambient-temperature Black Body Target
- An external Cryogenic Target filled with 15 liters of liquid nitrogen (LN2)

#### **Using the Cryogenic Target**

When LN2 is placed in a Cryogenic Target containing microwave absorber (Figure E-1), the target brightness temperature will be that of boiling LN2 (-195° C).

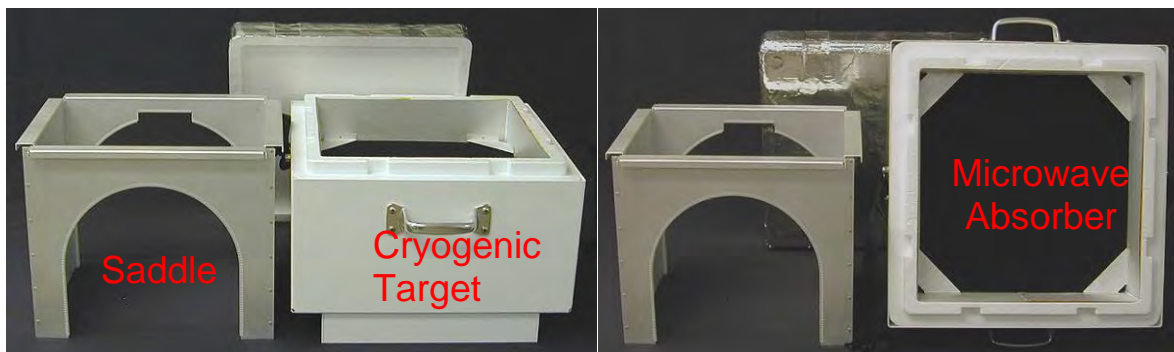

**Figure E-1. Cryogenic Target used to calibrate microwave-profiling radiometers**

The LN2 calibration procedure points the radiometer internal mirror to alternately view the ambient temperature Black Body Target and the Cryogenic Target (refer to Section 2 of the **Radiometrics Profiler Operator's Manual** for additional information on the radiometer antenna pointing mechanism).

When a calibration is performed, the Cryogenic Target is placed on top of the radiometer, above the Radome as shown in Figure E-2. Instructions for proper placement of the Saddle and Cryogenic Target are given below.



**Figure E-2. Radiometer with Saddle and Cryogenic Target in place**

The Saddle is used to position the Cryogenic Target above the radiometer Radome. It also forms a wave guide that serves to minimize extraneous microwave emissions (warm bias) reaching the antenna. The radiometer “views the target” through a Radiometrics-patented microwave transparent window in the bottom of the target.

Note that one end of the Saddle has a notch that fits over the rain sense board on the Superblower, when properly installed. The Saddle is designed so that the front cut out fits over the Superblower and the rear cut out fits against the hood immediately behind the Radome. When properly installed, the Saddle fits securely to the radiometer with no gaps between the Saddle and the hood (except at the bottom of the Saddle) as shown below in Figure E-3.

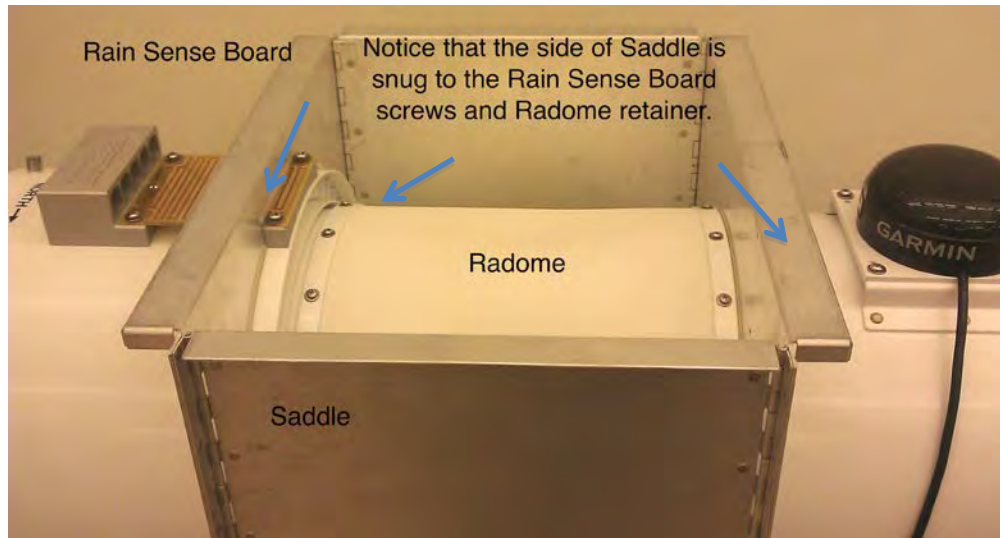

**Figure E-3. Saddle for Cryogenic Target, properly seated**

## Safety Considerations

Ensure proper LN2 handling safety by filling the Cryogenic Target while it is sitting on the ground, as shown Figure 4. Use the safety strap to secure the lid to the target before placing the target on the Saddle.

**NEVER** attempt to pour LN2 into the target when it is on the radiometer.

### **NOTE:**

Do not fill the Cryogenic Target until the operator is ready to start calibration. Load Cryogenic Target onto the Saddle from the front **only**.

Before starting an LN2 calibration:

1. Ensure the radiometer has been powered on for more than one hour to allow the microwave components to reach stable operating temperatures.
2. Stop the current procedure file if one is running.
3. Disconnect the Azimuth Positioner cable (if installed) from the radiometer.
4. Place the Saddle on the radiometer as described above, and place the filled Cryogenic Target on top of the Saddle.

Carefully pour LN2 into the Cryogenic Target until the LN2 level is at least one cm above the microwave absorber. Do not overfill – there should be at least a 2.5 cm (1 inch) gap between the LN2 and the top of the target.



**Figure E-4. Proper method for safely pouring LN2 into the Cryogenic Target**

Note that when the Cryogenic Target is properly seated on the Saddle, the two handles are oriented as shown in Figure E-2, and the target is level on the Saddle.

Additional information on LN2 availability, transport and storage is provided at the end of this appendix.

#### **Calibration procedure using the Single-User Interface:**

Start the Operating Code in Manual Mode. Check the Tknd0 and Tknd1 temperatures for stability ( $323.15\text{ K} \pm 0.1\text{ K}$  typical). When the instrument is ready, press **3** to start the LN2 Calibration. The calibration will begin automatically and continue until the user terminates it with a “**Q**” command (Quit). Allow the calibration to continue for 1-2 hours, provided that dry conditions prevail, and condensation on the target is not observed or expected. If condensation on the bottom of the target is likely to form, due to high humidity ( $\text{RH} > 70\%$ ), then the calibration should be shortened to ~30 minutes.

During the calibration, the Operating Code will display the calibration elapsed time, and a graph of Tnd for each channel as shown in Figure E-5. LN2 calibration observations are logged in a file named **yyyy-mm-dd\_hh-mm-ss\_In2.csv** where yyyy-mm-dd\_hh-mm-ss is the start time of the calibration.

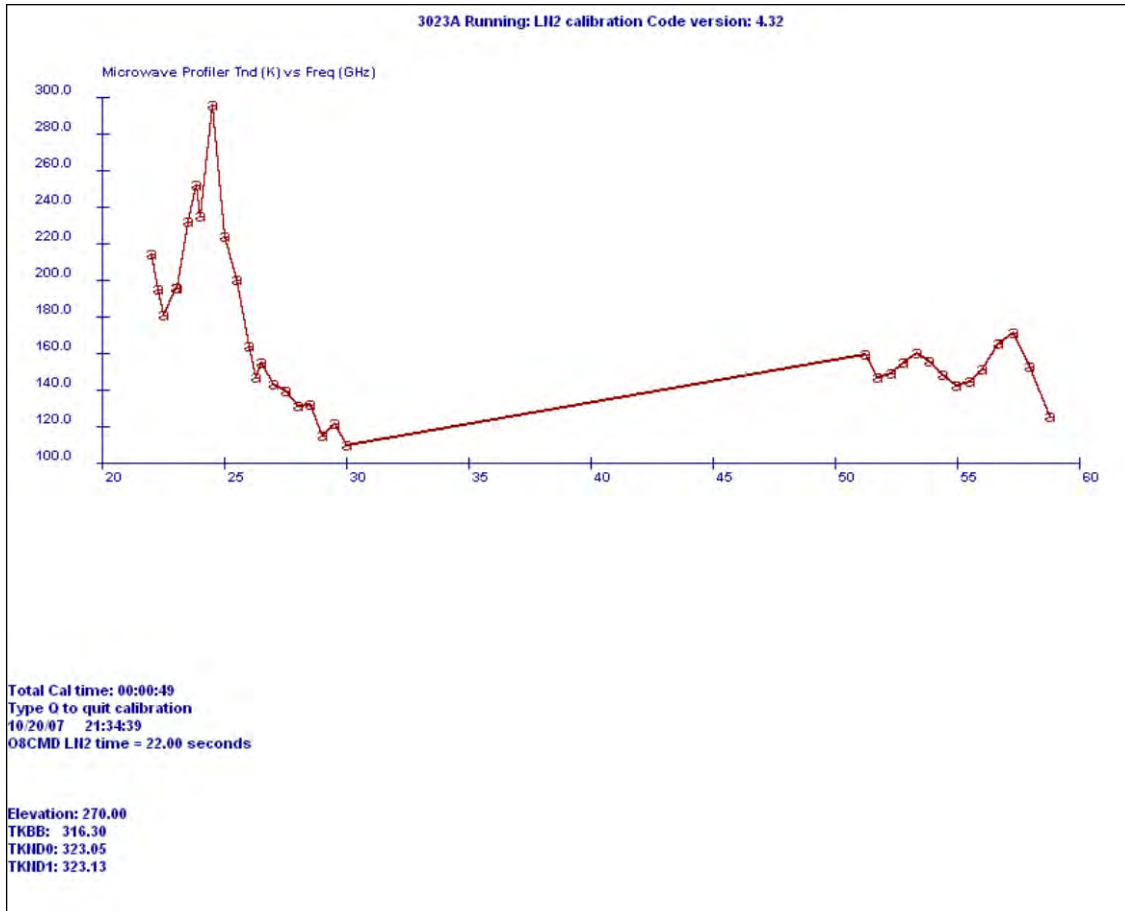

**Figure E-5. LN2 calibration display**

When the user presses the **Q** key to end the calibration, the Operating Code automatically computes new Tnd calibration values for all channels, and then terminates execution. The Operating Code writes these values to the operational configuration file (mp.cfg) and archives the previous configuration file with a file name indicating the date/time corresponding to the time of the calibration (i.e., 2007-01-10\_18-29-16.cfg). The Operating Code logs the date of the user LN2 calibration in the new configuration file in the Channel Calibration Block.

There are two methods to verify that the calibration completed correctly. First, the new and previous configuration files can be opened and inspected using the text editor **Notepad**. When closing these files, be sure **not** to “save changes”. Unless the calibration follows repairs or changes to the hardware, the new values of alpha, dTdG and Tnd should be close to the previous values. Typically, alpha will be in the range of 0.9 to 1.1, dTdG will be in the range of -100,000 to -5,000,000, and Tnd will be within 1-2% of the value computed in the previous known good calibration. Departure from these guidelines may indicate a poor calibration.

Second, to verify that moisture did not corrupt the calibration, open and plot the values of Tnd in the LN2 calibration file (**yyyy-mm-dd\_hh-mm-ss\_ln2.csv**). If the values of

Tnd are reasonably constant over time (only a small amount of random noise, but no long-term drift up or down), then the calibration is good. Figure E-6 shows a plot of the data in a typical MP-3000A LN2 calibration file. Notice that all channels remain constant over the duration of the calibration and the noise level is very low. These checks provide high confidence that a successful, accurate calibration has been achieved.

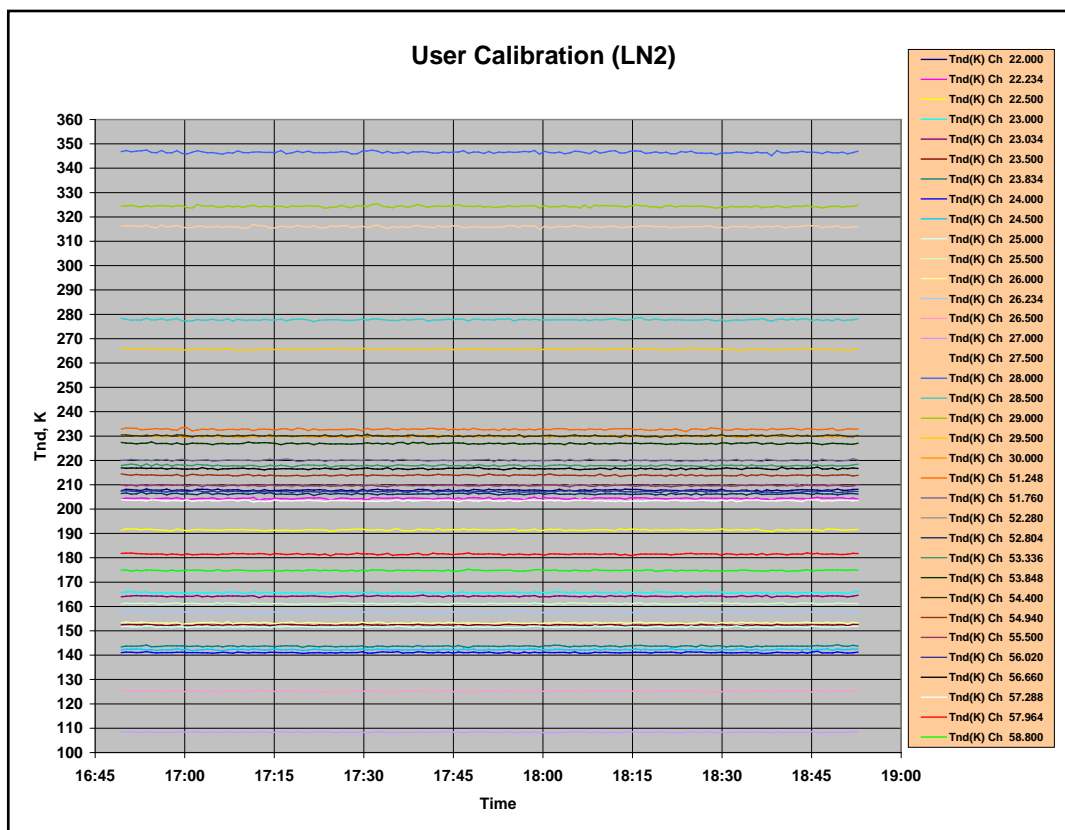

Figure E-6. Tnd values from user LN2 calibration (Excel plot)

## LN2 Calibration Verification Test

While the target is still on the Saddle, the new calibration can be further verified by running a special procedure that alternates between views of the internal Black Body Target (elevation angle = 270 degrees) and the external cryogenic target (elevation angle = 90 degrees). It is best to start this verification immediately after the calibration completes, while the target still has sufficient LN2, and moisture has not started to build up on the bottom surface. A test Procedure File is included in the standard procedure list to do this. To run this procedure, restart the Operating Code (double click on the radiometer icon on the desk top), then select option **1** (Standard Procedure), then scroll to the Procedure File named B&L35.prc. Press **Return** to begin the verification procedure. Press **1** to select the Brightness Temperature Display. After a few observation cycles have completed, the display will begin showing the sky brightness temperature for all channels, switching back and forth between the internal ambient and external Cryogenic Targets.

If the calibration was successful, then the brightness temperatures for all channels should closely match the calculated values of the effective target temperature (typically, 77-80 K, depending on barometric pressure). If the target has not been moved on the Saddle, and the LN2 level has not dropped below the black absorbing foam in the target, then the average of the cryogenic target observation errors (observations minus effective target temperature) should be  $< 0.5$  K. The average of the ambient target observation errors (target observation minus  $T_{kBB}$ ) should be  $< 0.5$  K.

It is sufficient to observe the Brightness Temperature Display for a few cycles of the procedure to verify that all channels were calibrated reasonably well. However, to calculate the errors more precisely, allow the B&L35.prc procedure to run for approximately 1-2 hours, then press **Q** to Quit. Open the new *level1* file in a spreadsheet or data analysis application to calculate the brightness temperature error ( $T_{\text{observed}} - T_{\text{target}}$ ) for each record, and the average of the errors for each channel. Figure E-7, Figure E-8 and Figure E-9 show examples of the data from a post user cal B&L test. See Section 5 of the **Radiometrics Profiler Operator's Manual** for additional information on data files and data processing techniques.

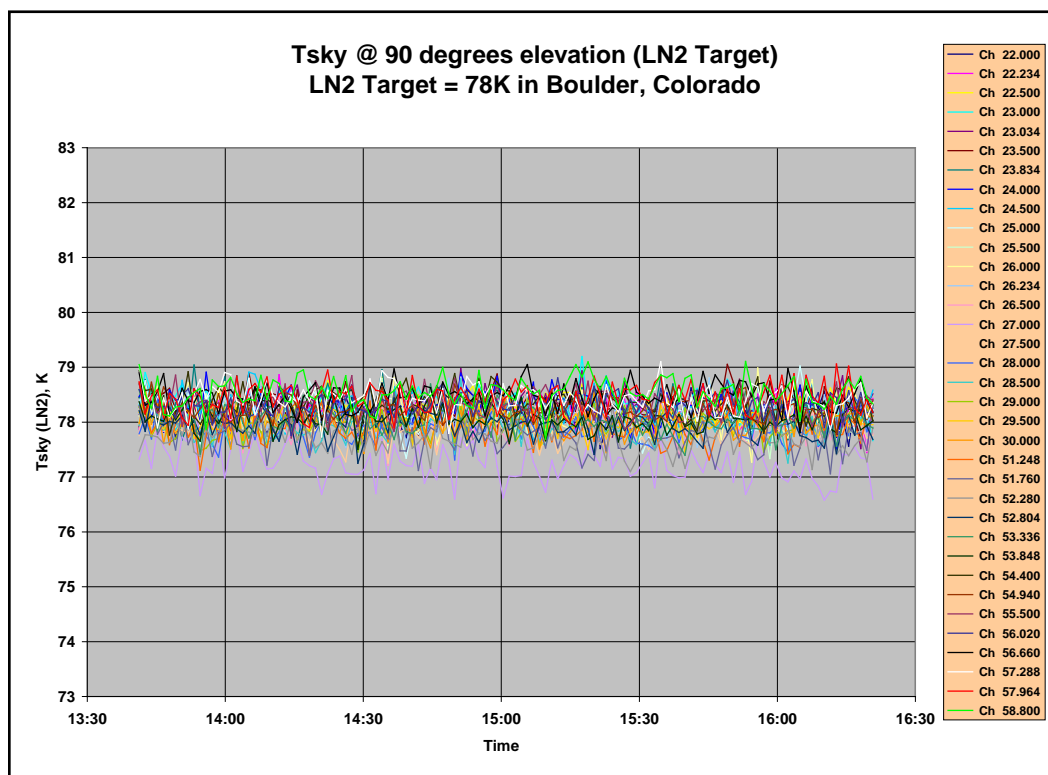

Figure E-7. Example of B&L Cryogenic Target for MP-3000A (Excel plot)



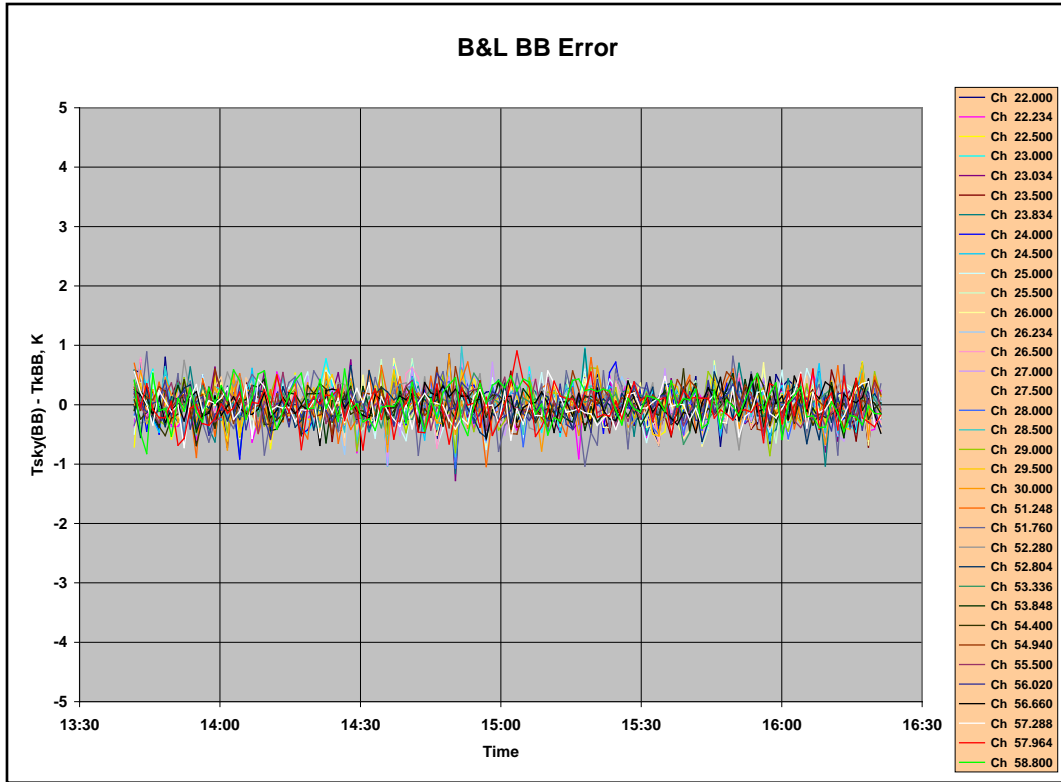

Figure E-8. Example of B&L temperature error for MP-3000A (Excel plot)

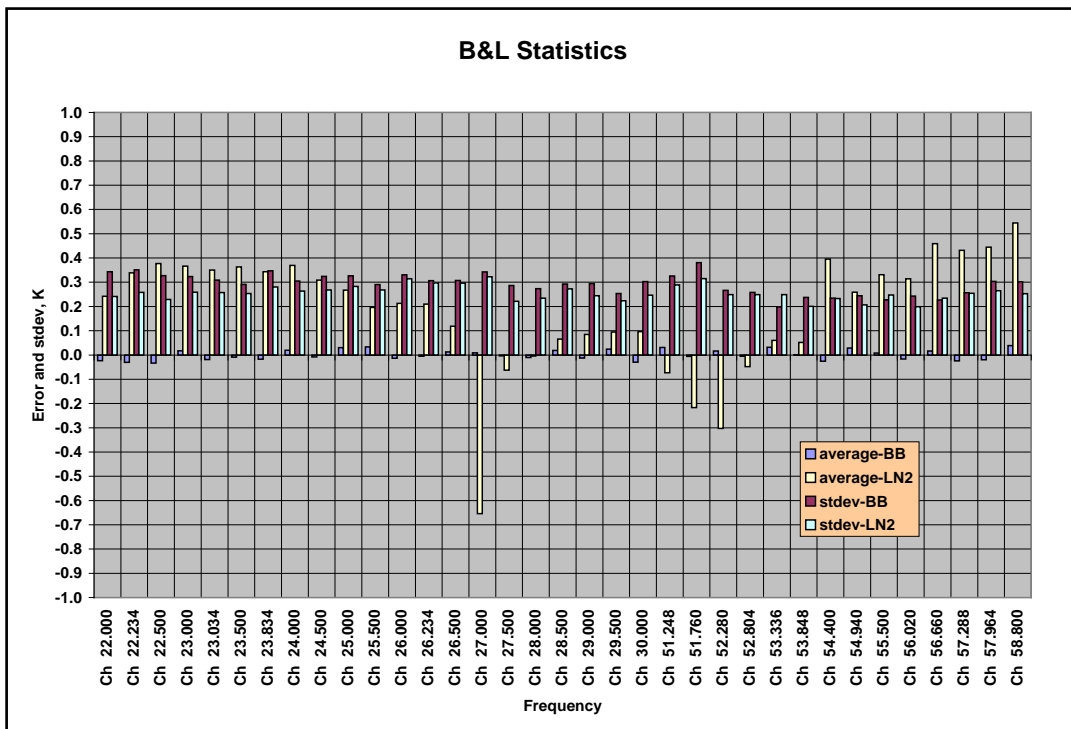

Figure E-9. Example of B&L statistics for MP-3000A (Excel plot)

## LN2 availability, transport and storage

Nitrogen is the most abundant naturally occurring gas in the earth's atmosphere (78%). When we breathe, we breathe mostly nitrogen into our lungs. It is not toxic in normal concentrations. LN2 is used for many industrial and medical purposes. Because it is so abundant and non-toxic, it is relatively easy to manufacture and use. It is readily available from any industrial gas supplier. It is often available in limited quantities from local hospitals if there is no industrial gas supplier nearby.

LN2 is typically delivered from suppliers in large (160 liter) Dewars, as shown in Figure E-10. It can also be purchased in smaller quantities.



**Figure E-10. Dewars used for storing and handling LN2**

For short-term use, Dewars can be rented from many industrial gas suppliers. Dewars are also available for sale from Radiometrics. Dewars can be used to transport and short-term storage (typically less than 24 hours).



**Figure D-11. Handling LN2: filling Cryogenic Target (left), pouring residual LN2 into Dewar after calibration is finished (right)**

Contact Radiometrics Corporation Customer Service for additional information on radiometer LN2 calibration.

## ***E.2 Radiometer Calibration***

There are seven parameters associated with every microwave channel that are individually calibrated to provide the highest level of accuracy overall operating conditions. The surface met sensors also contribute to the accuracy of level2 data products. Most of the Profiling Radiometer parameters that require calibration remain stable for many years. All these parameters are calibrated at the factory, *over the full operating temperature range*, and normally require no user adjustment. The seven factory-calibrated parameters associated with each microwave channel are:

- alpha            linearity correction exponent
- dTdG            1/f noise suppression coefficient
- K1                zero order coefficient of Tnd temperature dependent correction
- K2                1<sup>st</sup> order coefficient of Tnd temperature dependent correction
- K3                2<sup>nd</sup> order coefficient of Tnd temperature dependent correction
- K4                3<sup>rd</sup> order coefficient of Tnd temperature dependent correction
- Tnd@290        effective Noise Diode Temperature at TkBB = 290K

These seven parameters are used to compute brightness temperature in accordance with the transfer function described in Section 1.4 of the **Radiometrics Profiler Operator's Manual**.

The *effective* Noise Diode Temperature ( $T_{nd}$ ) is very stable, but it should be recalibrated after transport of the instrument, and once every 3-6 months to ensure the highest accuracy. Two methods are available to calibrate the Noise Diode “secondary gain standards” using “primary standards”. The “LN2 calibration method” is applicable to all microwave channels in all models. The “TIP calibration method” is only applicable to the relatively transparent K band channels MP-3000A model. Each method has strengths and weaknesses described below.

The instrument configuration file (mp.cfg) contains all the settings and parameters associated with the operation of an instrument. The Channel Calibration Block in the configuration file contains the factory calibration data unique to each instrument RF subsystem. It contains data for each channel in each receiver (22-30 and 51-59 GHz as applicable). Figure E-11 shows an example of a typical Channel Calibration Block for the 35-channel MP-3000A.

**NOTE:**

Except as noted below, values in this table should not be changed unless directed to do so by factory service personnel.

**CALIBRATION BLOCK:**

2006/08/11 22:22:39 Date of last factory LN2 calibration

2007/03/02 18:03:04 Date of last user LN2 calibration

.90 :target tolerance for ln2 cal

35 :number of frequencies

| Frequency | MRT   | Window Coef | ND drive | IF Atten | alpha  | dtgd      | k1        | k2        | k3        | k4        | Tnd     |
|-----------|-------|-------------|----------|----------|--------|-----------|-----------|-----------|-----------|-----------|---------|
| 22.000    | 275.0 | 0.000140    | 22000    | 18.5     | 1.0564 | -8.89E+05 | -7.51E+00 | 3.85E-02  | -6.53E-05 | 7.53E-08  | 173.250 |
| 22.234    | 275.0 | 0.000140    | 22000    | 18.5     | 1.0437 | -7.98E+05 | -7.01E+00 | 1.01E-01  | -5.24E-04 | 8.98E-07  | 155.140 |
| 22.500    | 275.0 | 0.000140    | 22000    | 18.5     | 1.0360 | -7.91E+05 | -2.16E+02 | 2.24E+00  | -7.80E-03 | 9.12E-06  | 151.090 |
| 23.000    | 275.7 | 0.000140    | 22000    | 18.5     | 1.0218 | -6.50E+05 | -5.21E+01 | 4.92E-01  | -1.61E-03 | 1.84E-06  | 144.360 |
| 23.034    | 275.7 | 0.000140    | 22000    | 18.5     | 1.0238 | -6.53E+05 | 3.69E+01  | -4.37E-01 | 1.61E-03  | -1.87E-06 | 143.920 |
| 23.500    | 275.7 | 0.000140    | 22000    | 18.5     | 1.0181 | -6.02E+05 | -5.47E+01 | 5.40E-01  | -1.85E-03 | 2.19E-06  | 159.320 |
| 23.834    | 276.0 | 0.000150    | 22000    | 18.5     | 1.0154 | -6.53E+05 | 6.07E+00  | -6.93E-02 | 1.81E-04  | -4.79E-08 | 151.430 |
| 24.000    | 275.7 | 0.000140    | 22000    | 18.5     | 1.0184 | -6.73E+05 | -2.47E+01 | 2.18E-01  | -6.54E-04 | 6.73E-07  | 145.060 |
| 24.500    | 275.7 | 0.000140    | 22000    | 18.5     | 1.0394 | -7.63E+05 | -3.68E+01 | 3.33E-01  | -1.03E-03 | 1.11E-06  | 184.940 |
| 25.000    | 275.4 | 0.000164    | 22000    | 18.5     | 1.0519 | -9.40E+05 | 1.33E+01  | -1.59E-01 | 5.32E-04  | -4.93E-07 | 141.490 |
| 25.500    | 275.4 | 0.000164    | 22000    | 18.5     | 1.0592 | -9.36E+05 | -1.28E+01 | 9.46E-02  | -3.20E-04 | 5.06E-07  | 158.860 |
| 26.000    | 275.4 | 0.000164    | 22000    | 18.5     | 1.0712 | -8.00E+05 | 3.20E+01  | -3.60E-01 | 1.27E-03  | -1.43E-06 | 137.290 |
| 26.234    | 275.4 | 0.000164    | 22000    | 18.5     | 1.0723 | -7.10E+05 | 5.81E+01  | -6.20E-01 | 2.13E-03  | -2.34E-06 | 143.860 |
| 26.500    | 275.4 | 0.000164    | 22000    | 18.5     | 1.0685 | -6.58E+05 | -2.13E+01 | 2.44E-01  | -1.02E-03 | 1.47E-06  | 168.390 |
| 27.000    | 275.4 | 0.000164    | 22000    | 18.5     | 1.0629 | -5.87E+05 | 3.20E+01  | -3.88E-01 | 1.46E-03  | -1.72E-06 | 160.490 |
| 27.500    | 275.4 | 0.000164    | 22000    | 18.5     | 1.0537 | -5.80E+05 | -8.01E+01 | 8.46E-01  | -3.08E-03 | 3.85E-06  | 187.580 |
| 28.000    | 275.4 | 0.000164    | 22000    | 18.5     | 1.0444 | -6.39E+05 | -3.38E+01 | 2.80E-01  | -7.93E-04 | 7.88E-07  | 210.880 |
| 28.500    | 274.1 | 0.000200    | 22000    | 18.5     | 1.0407 | -7.84E+05 | -1.29E+02 | 1.32E+00  | -4.64E-03 | 5.55E-06  | 213.600 |
| 29.000    | 274.1 | 0.000200    | 22000    | 18.5     | 1.0397 | -1.11E+06 | -1.22E+02 | 1.28E+00  | -4.54E-03 | 5.45E-06  | 234.990 |
| 29.500    | 274.1 | 0.000200    | 22000    | 18.5     | 1.0347 | -9.59E+05 | -1.94E+02 | 2.03E+00  | -7.11E-03 | 8.37E-06  | 189.640 |
| 30.000    | 274.1 | 0.000200    | 22000    | 18.5     | 1.0315 | -1.21E+06 | -8.08E+01 | 8.77E-01  | -3.26E-03 | 4.11E-06  | 184.890 |
| 51.248    | 274.1 | 0.000200    | 45000    | 20.5     | 1.0500 | -8.56E+05 | 2.01E+01  | -1.14E-01 | -2.95E-05 | 6.37E-07  | 181.500 |
| 51.760    | 274.1 | 0.000200    | 45000    | 20.5     | 1.0570 | -1.28E+06 | -4.52E+01 | 4.90E-01  | -1.86E-03 | 2.46E-06  | 192.020 |
| 52.280    | 274.1 | 0.000200    | 45000    | 20.5     | 1.0590 | -7.56E+05 | -1.90E+01 | 2.16E-01  | -9.93E-04 | 1.64E-06  | 226.450 |
| 52.804    | 274.1 | 0.000200    | 45000    | 20.5     | 1.0566 | -7.62E+05 | -4.76E+01 | 4.01E-01  | -1.25E-03 | 1.50E-06  | 218.580 |
| 53.336    | 274.1 | 0.000200    | 45000    | 20.5     | 1.0512 | -7.13E+05 | -8.90E+01 | 9.01E-01  | -3.22E-03 | 4.04E-06  | 165.690 |
| 53.848    | 274.1 | 0.000200    | 45000    | 20.5     | 1.0507 | -7.36E+05 | -1.06E+02 | 1.07E+00  | -3.63E-03 | 4.20E-06  | 136.590 |
| 54.400    | 274.1 | 0.000200    | 45000    | 20.5     | 1.0547 | -7.46E+05 | -6.54E+00 | 3.19E-02  | -8.58E-05 | 1.84E-07  | 138.260 |
| 54.940    | 274.1 | 0.000200    | 45000    | 20.5     | 1.0634 | -9.87E+05 | 7.78E+01  | -7.68E-01 | 2.40E-03  | -2.32E-06 | 158.610 |
| 55.500    | 274.1 | 0.000200    | 45000    | 20.5     | 1.0600 | -9.65E+05 | -2.63E+01 | 2.35E-01  | -8.44E-04 | 1.20E-06  | 168.490 |
| 56.020    | 274.1 | 0.000200    | 45000    | 20.5     | 1.0504 | -7.68E+05 | 1.76E+01  | -2.27E-01 | 8.05E-04  | -8.00E-07 | 143.740 |
| 56.660    | 274.1 | 0.000200    | 45000    | 20.5     | 1.0603 | -8.32E+05 | -2.10E+01 | 2.05E-01  | -7.54E-04 | 1.02E-06  | 118.280 |
| 57.288    | 274.1 | 0.000200    | 45000    | 20.5     | 1.0680 | -1.06E+06 | -4.07E+01 | 4.01E-01  | -1.39E-03 | 1.70E-06  | 124.880 |
| 57.964    | 274.1 | 0.000200    | 45000    | 20.5     | 1.0545 | -8.97E+05 | 9.25E+00  | -8.72E-02 | 1.71E-04  | 6.80E-08  | 146.690 |
| 58.800    | 274.1 | 0.000200    | 45000    | 20.5     | 1.0574 | -1.28E+06 | -3.17E+01 | 2.92E-01  | -9.91E-04 | 1.25E-06  | 138.380 |

**Figure E-11. Example of Channel Block Configuration File****E.3 LN2 Calibration**

The Noise Diodes in Profiling Radiometers are used as the “secondary standard” to measure *system gain* in each channel for each observation. When enabled, they add a calibrated increase to the brightness temperature. When the value of Tnd is not known, it can be determined by observing two targets of known temperature. In the fully automated method used by Radiometrics, the built in ambient Black Body target provides one target of known temperature for the calibration, and an external Cryogenic Target, filled with LN2, provides the second. The ambient target physical temperature (TkBB) is measured by the instrument each time a **Trvc** command is executed. The

Operating Code automatically calculates effective target temperature of the Cryogenic Target, based on the equation that follows.

### Contributions to Cold Target Temperature

Temperature contributions to the patented cryogenic calibration target developed by Radiometrics include:

- insertion loss of the polystyrene insulation that contains the target and absorbing foam (the insertion loss contributes to temperature by re-radiating to the same extent as the absorption)
- reflection from the polystyrene-LN2 interface
- reflection from the surface of the absorbing foam that is immersed in LN2
- elevation in boiling point of the LN2 due to the hydrostatic pressure associated with the depth

These contributions are automatically taken into account by the automated calibration through coefficients held in the configuration file (mp.cfg).

The boiling point of LN2 (TLN2) is a weak function of ambient barometric pressure P:

$$TLN2(K) = 68.23 + 0.009037 * P(mb)$$

The physical temperature of the LN2 target is determined by the local LN2 temperature. The hydrostatic load must therefore be added to the atmospheric pressure at the surface of the LN2. This hydrostatic pressure enhancement is about 1.2 mb/cm of depth. At a 20 cm depth of LN2, the temperature increase is about 0.22° K. The various components contributing to the effective Black Body temperature are summarized in Table 6. An ambient temperature of 300° K and a target temperature of 77° K are assumed.

| Contribution   | Amount   |
|--|----------|
| Insertion loss at 55 GHz of polystyrene containing LN2           | 0.26° K  |
| Air-polystyrene interface reflection                             | 0.002° K |
| Polystyrene-LN2 interface reflection                             | 1.74° K  |
| LN2-absorbing foam interface reflection                          | 0.00° K  |
| Increase in boiling point due to 20 cm hydrostatic column of LN2 | 0.22° K  |
| Total contribution at 300° K ambient temperature                 | 2.22° K  |

**Table 6. Typical contributions to Cryogenic Target Black Body temperature**

## LN2 Calibration Precautions

***Refer to Appendix D for details on LN2 calibration.***

When performing the LN2 calibration, a number of precautions must be observed:

- To achieve the best possible calibration accuracy, the bottom of the target must be clean and dry. The Profiling Radiometer “looks” through the target bottom. Any dirt, debris, or moisture on the bottom of the target will contribute an error to the effective target temperature. If necessary, the target should be cleaned with mild soap and water, and allowed to thoroughly dry before use.
- The Profiling Radiometer must be at its stable operating temperature. Thus, the Profiling Radiometer should be turned on for a period of at least 30 minutes before the calibration begins. It is always best if the instrument has been on for several hours. (It is not necessary for the software to be running.)
- When LN2 is in the target, the outside will eventually cool, and may reach the atmospheric dew point temperature. This may cause condensation on the outside bottom surface of the target, which causes error. Therefore, the target should not be filled until shortly before calibration begins. The Superblower will help to minimize condensation, as will performing the calibration on days when the humidity is low (dew point is depressed). The user LN2 calibration may not produce accurate results if the ambient RH > 70%.
- The calibration procedure should be allowed to continue for 1-2 hours to obtain a large number of observations, thereby reducing measurement noise.

### **WARNING**

**Contact with LN2 can cause burns and skin damage — handle with care!**

## LN2 User Calibration Procedure

### **NOTE:**

Be sure to disconnect the Azimuth drive prior to calibrating the radiometer with LN2. LN2's cold temperature could damage components of the Azimuth drive, if spillage were to occur.

### ***TIP Calibrations***

The use of an external Cryogenic Target is required to calibrate the Noise Diodes in 51-59 GHz receivers. The LN2 calibration process described above also calibrates the Noise Diode in the 22-30 GHz receiver. However, because the zenith brightness temperature in the 22-30 GHz band are typically less than 50 K under clear skies, the 22-30 GHz receiver Noise Diode can also be calibrated using a “TIP derived calibration”. In this method, the Profiling Radiometer uses the atmosphere itself as a “cold target”.

By observing the brightness temperature of the sky at several elevation angles in rapid succession, the Profiling Radiometer can calculate an estimate of the 22-30 GHz Noise Diode temperatures. The 51-59 GHz Noise Diodes cannot be reliably calibrated using the TIP method due to the relatively small temperature difference observed between the built-in ambient Black Body target and some of the more opaque channels.

### **LN2 vs. TIP Calibrations: Strengths and Weaknesses**

The LN2 and TIP calibration methods each have their own strengths and weaknesses. The following example will illustrate why the LN2 calibration method works best for the 51-59 GHz band, while the TIP method has certain advantages in the 22-30 GHz band.

Assume for the purpose of this cryogenic calibration example that the ambient Black Body target is at 278 K, and there is no ambient target error. Then assume a cryogenic LN2 target at 78 K, but with a 2 K error. This effective LN2 target temperature error will produce a sky brightness temperature with a 1% gain error [ $2/(278-78)$ ]. This manifests as a 2 K error for  $T_{\text{sky}} = 78$  K, a 1 K error for  $T_{\text{sky}} = 178$  K, but only 0.2 K error for  $T_{\text{sky}} = 258$  K. Since most 51-59 GHz channels produce sky brightness temperatures much closer to ambient than the Cryogenic Target (78 K), a relatively large target error does not impact the 51-59 GHz channels as much as it would a 22-30 GHz channel, where the sky brightness temperature is sometimes less than 10 K. Thus, for a given effective LN2 target temperature error, the impact is generally much less in the 51-59 GHz channels than it is in the 22-30 GHz channels. Fortunately, the TIP calibration method works best on the coldest radiometer channels, where the Cryogenic Target is weakest, and the Cryogenic Target works best for the warmest channels, where the TIP method breaks down.

Of course, the TIP calibration method also has error sources, but for 22-30 GHz, these errors can be managed to a level lower than the typical Cryogenic Target induced error. To obtain a high quality TIP calibration, make sure the Profiling Radiometer is level, and use a spreadsheet to select only data from observation periods when the atmosphere is very stable. This process will be described in detail in Section 0.

### **TIP Calibration Procedure**

To calibrate the 22-30 GHz channels with the TIP method, use the following procedure:

1. Specify the elevation angles to be used in the TIP Configuration section of the configuration file (mp.cfg), if necessary. The default values (30, 45, 90, 135, 150 degrees) usually provide excellent results. In most cases, the use of complementary angles (i.e., 30 and 150) will provide the best results since they tend to compensate for instrument leveling error and atmospheric gradients.
2. Collect TIP data for at least a few hours during a time when the atmosphere is generally stable. A full day or more may be necessary at times and in areas where the atmosphere is rarely stable. If necessary, collect TIP data for several days to make sure a stable period is included. Select a Procedure File that includes frequent periodic **cal21** commands. The **cal21** command collects TIP



calibrations on all 21 K band channels. The standard Procedure File xxx\_zen\_ret\_tip.prc (where xxx is the site code) will produce alternating TIP calibrations, zenith observations and 26 input zenith NN retrievals. New TIP data and the current operational values of Tnd can be viewed graphically in real-time by pressing the T key to check for differences.

- Open the *TIP* data file (yyyy-mm-dd\_hh-mm-ss\_tip.csv) in Excel, or a similar data analysis application with graphing capability. Graph the values of Tnd for all 21 channels as a function of time. See **Figure E-12. Example of TIP data plotted as a function of time** for an example. Inspect the graph and select a period when all 21 channels have minimal atmospherically induced noise and maximum stability (no slope). Note a stable time period of several hours or more.

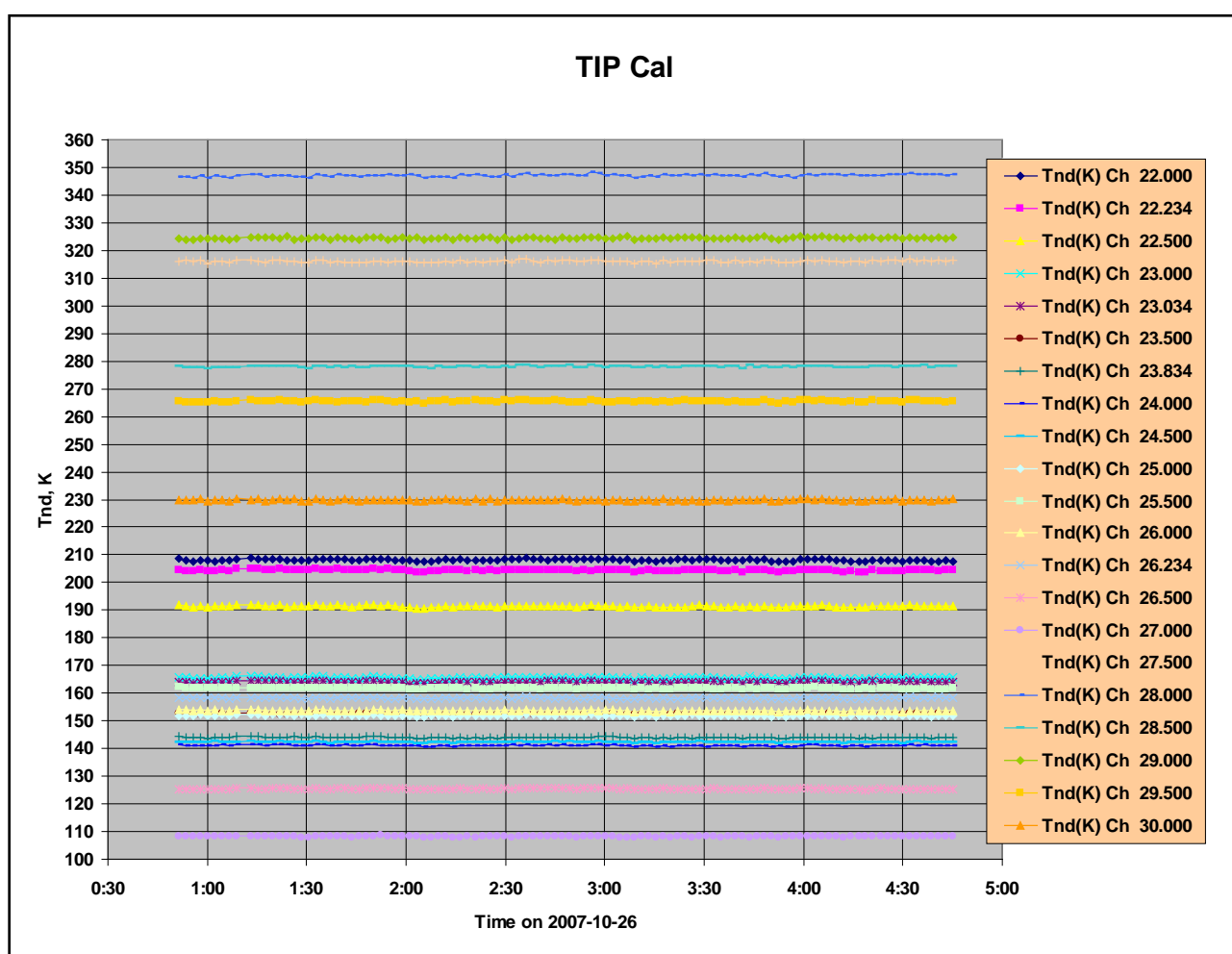

**Figure E-12. Example of TIP data plotted as a function of time**

- Once a stable period of observations has been determined from the time series, compute the average values of Tnd for each channel for that period. See **Figure E-13. Example of a processed TIP data file displayed in Excel** for an example

of processed a *TIP* data file displayed in Excel. In this example, only the first and last few observation records are displayed (records 25-124 are hidden for clarity), and only the first 12 of 21 channels are displayed. Highlighted cells are computed values. The standard Excel “average()” function is used to calculate the average of a range of data in each of the 21 columns of Noise Diode Temperature (Tnd). The average value of Tnd for each channel is copied to the column “Tnd-TIP” for comparison to the current operational values of Tnd, which are always recorded in the header of the tip.csv file for easy reference. The next column, deltaTnd, is computed to find the difference, expressed as a percent, between the current operating values of Tnd and the Tnd values determined from TIPs. In this example, the TIP derived values of Tnd agree very closely with the current values in use (which were derived with a LN2 user calibration), so there is no need to change the operational values.

| Record | Date/Time       | 10 | Freq            | Rcvr             | Alpha            | dTdg             | K1               | K2               | K3               | K4               | Tnd              | Tnd-TIP          | deltaTnd (LN2-TIP) |                  |                  |
|--------|-----------------|----|-----------------|------------------|------------------|------------------|------------------|------------------|------------------|------------------|------------------|------------------|--------------------|------------------|------------------|
| 1      | 10/26/2007 0:49 | 11 | 22.000          | 0                | 0.9962           | -378333          | 2.21E+02         | -2.35E+00        | 8.23E-03         | -9.44E-06        | 207.740          | 208.143          | -0.19%             |                  |                  |
| 2      | 10/26/2007 0:49 | 11 | 22.234          | 0                | 0.9955           | -338965          | 2.17E+02         | -2.27E+00        | 7.91E-03         | -9.19E-06        | 204.330          | 204.376          | -0.02%             |                  |                  |
| 3      | 10/26/2007 0:49 | 11 | 22.500          | 0                | 0.9941           | -363201          | 8.21E+01         | -1.01E+00        | 3.93E-03         | -4.93E-06        | 191.390          | 191.370          | 0.01%              |                  |                  |
| 4      | 10/26/2007 0:49 | 11 | 23.000          | 0                | 0.9906           | -365338          | 1.61E+02         | -1.76E+00        | 6.33E-03         | -7.52E-06        | 165.590          | 165.608          | -0.01%             |                  |                  |
| 5      | 10/26/2007 0:49 | 11 | 23.034          | 0                | 0.9913           | -374305          | 1.45E+02         | -1.58E+00        | 5.63E-03         | -6.59E-06        | 164.120          | 164.015          | 0.06%              |                  |                  |
| 6      | 10/26/2007 0:49 | 11 | 23.500          | 0                | 0.9957           | -448631          | -5.84E+01        | 5.96E-01         | -2.01E-03        | 2.24E-06         | 152.360          | 152.316          | 0.03%              |                  |                  |
| 7      | 10/26/2007 0:49 | 11 | 23.834          | 0                | 0.9941           | -327088          | 1.50E+00         | 2.96E-02         | -2.45E-04        | 4.33E-07         | 143.600          | 143.984          | -0.27%             |                  |                  |
| 8      | 10/26/2007 0:49 | 11 | 24.000          | 0                | 0.9943           | -337626          | 3.41E+01         | -4.03E-01        | 1.56E-03         | -1.98E-06        | 140.970          | 140.982          | -0.01%             |                  |                  |
| 9      | 10/26/2007 0:49 | 11 | 24.500          | 0                | 0.9947           | -375843          | 1.03E+02         | -1.09E+00        | 3.84E-03         | -4.50E-06        | 142.160          | 142.227          | -0.05%             |                  |                  |
| 10     | 10/26/2007 0:49 | 11 | 25.000          | 0                | 0.9938           | -376416          | 6.68E+01         | -6.77E-01        | 2.31E-03         | -2.67E-06        | 151.500          | 151.879          | -0.25%             |                  |                  |
| 11     | 10/26/2007 0:49 | 11 | 25.500          | 0                | 0.9937           | -359917          | 1.53E+02         | -1.53E+00        | 5.23E-03         | -6.05E-06        | 161.070          | 161.731          | -0.41%             |                  |                  |
| 12     | 10/26/2007 0:49 | 11 | 26.000          | 0                | 0.9944           | -502846          | 1.58E+02         | -1.59E+00        | 5.51E-03         | -6.54E-06        | 153.130          | 153.617          | -0.32%             |                  |                  |
| 13     | 10/26/2007 0:49 | 11 | 26.234          | 0                | 0.9961           | -485410          | 1.17E+02         | -1.12E+00        | 3.82E-03         | -4.67E-06        | 157.570          | 158.217          | -0.41%             |                  |                  |
| 14     | 10/26/2007 0:49 | 11 | 26.500          | 0                | 0.9957           | -455262          | 6.07E+00         | -1.52E-01        | 7.68E-04         | -1.09E-06        | 125.000          | 125.410          | -0.33%             |                  |                  |
| 15     | 10/26/2007 0:49 | 11 | 27.000          | 0                | 0.9973           | -571139          | -2.20E+02        | 2.30E+00         | -8.05E-03        | 9.47E-06         | 108.240          | 108.204          | 0.03%              |                  |                  |
| 16     | 10/26/2007 0:49 | 11 | 27.500          | 0                | 0.9976           | -625081          | -3.08E+02        | 2.92E+00         | -9.56E-03        | 1.09E-05         | 315.860          | 315.986          | -0.04%             |                  |                  |
| 17     | 10/26/2007 0:49 | 11 | 28.000          | 0                | 0.9984           | -609425          | -2.52E+02        | 2.33E+00         | -7.68E-03        | 9.04E-06         | 346.410          | 346.964          | -0.16%             |                  |                  |
| 18     | 10/26/2007 0:49 | 11 | 28.500          | 0                | 0.9973           | -623955          | 7.94E+00         | -3.99E-01        | 1.93E-03         | -2.25E-06        | 277.600          | 277.930          | -0.12%             |                  |                  |
| 19     | 10/26/2007 0:49 | 11 | 29.000          | 0                | 0.9958           | -620806          | 2.05E+02         | -2.45E+00        | 9.02E-03         | -1.04E-05        | 324.140          | 324.434          | -0.09%             |                  |                  |
| 20     | 10/26/2007 0:49 | 11 | 29.500          | 0                | 0.9960           | -635232          | -2.54E+02        | 2.49E+00         | -8.52E-03        | 1.03E-05         | 265.500          | 265.452          | 0.02%              |                  |                  |
| 21     | 10/26/2007 0:49 | 11 | 30.000          | 0                | 0.9960           | -674979          | -2.64E+02        | 2.64E+00         | -9.10E-03        | 1.09E-05         | 229.690          | 229.739          | -0.02%             |                  |                  |
| Record | Date/Time       | 30 | TkBB(K)         | Tnd(K) Ch 22.000 | Tnd(K) Ch 22.234 | Tnd(K) Ch 22.500 | Tnd(K) Ch 23.000 | Tnd(K) Ch 23.034 | Tnd(K) Ch 23.500 | Tnd(K) Ch 23.834 | Tnd(K) Ch 24.000 | Tnd(K) Ch 24.500 | Tnd(K) Ch 25.000   | Tnd(K) Ch 25.500 | Tnd(K) Ch 26.000 |
| 22     | 10/26/2007 0:51 | 31 | 307.995         | 208.647          | 204.585          | 191.791          | 165.790          | 164.150          | 152.573          | 144.438          | 141.237          | 142.342          | 152.023            | 162.198          | 154.153          |
| 23     | 10/26/2007 0:53 | 31 | 307.560         | 208.067          | 204.186          | 191.388          | 165.545          | 163.903          | 152.263          | 144.078          | 141.077          | 142.204          | 151.708            | 162.006          | 153.946          |
| 24     | 10/26/2007 0:55 | 31 | 307.177         | 207.649          | 204.198          | 190.873          | 165.429          | 163.680          | 152.182          | 144.020          | 140.771          | 142.136          | 151.902            | 162.044          | 153.576          |
| 125    | 10/26/2007 4:38 | 31 | 299.329         | 207.704          | 204.318          | 191.311          | 165.566          | 163.960          | 152.399          | 143.736          | 140.955          | 142.075          | 151.523            | 161.499          | 153.504          |
| 126    | 10/26/2007 4:40 | 31 | 299.168         | 207.671          | 204.292          | 191.611          | 165.550          | 164.122          | 152.547          | 143.907          | 141.059          | 142.368          | 151.915            | 161.480          | 153.651          |
| 127    | 10/26/2007 4:42 | 31 | 299.002         | 207.942          | 204.493          | 191.527          | 165.892          | 164.156          | 152.236          | 144.106          | 141.063          | 142.285          | 151.776            | 161.562          | 153.355          |
| 128    | 10/26/2007 4:45 | 31 | 298.849         | 207.737          | 204.400          | 191.410          | 165.734          | 164.109          | 152.459          | 143.905          | 140.959          | 142.239          | 151.935            | 161.757          | 153.577          |
|        |                 |    | <b>average=</b> | 208.143          | 204.376          | 191.370          | 165.608          | 164.015          | 152.316          | 143.984          | 140.982          | 142.227          | 151.879            | 161.731          | 153.617          |

Figure E-13. Example of a processed *TIP* data file displayed in Excel

- To make the new TIP derived values of Tnd the operational values, open the configuration file (mp.cfg) using Notepad and manually replace the existing Tnd values with the new values, then save the file. Refer to Figure E-12 and Figure E-13 for the location of these values (last column in channel calibration block).

**NOTE:**

Be sure to open mp.cfg using only **Notepad** or another text editor, not a word processor application like MS Word or WordPad. These applications can corrupt the mp.cfg file.

## Surface Met Sensor Calibration

The Surface Met Sensors include ambient air temperature, relative humidity, barometric pressure, IRT (optional), and rain. All Profiling Radiometers are delivered with the Met Sensors pre-calibrated at the factory, ready to use. This Section provides general information about the Met Sensors. For detailed information on the maintenance and calibration of these sensors, refer to Section 6.1 of **Radiometrics Profiler Operator's Manual**.

### Temperature and Relative Humidity Sensor

Radiometrics Profiling Radiometers manufactured after March 2004 are fitted with a new Rain Mitigation System consisting of the Superblower and the hydrophobic radome. The Superblower uses increased airflow, but no heater (as used in previous models) to keep the radome dry.<sup>4</sup> The Superblower incorporates an ambient air temperature and RH sensor in the air-inlet where unbiased ambient air is constantly flowing over the sensor. The Superblower assembly also shades the sensor from direct sun. The sunshade and continuous airflow ensure negligible bias due to solar radiation.



**Figure E-14. Superblower with End Cover removed; sensor and filter**

The sensor is factory calibrated to a high standard, and normally requires no field calibration. If the user has access to very high accuracy field standards for  $T_{amb}$  and RH, and wishes to adjust the sensor calibrations in the field, linear offset values may be entered in the configuration file (mp.cfg) in place of the default values (0.0) as follows:

```
+0.00      :Tamb correction
+0.00      :Rh correction
```

Offset values for  $T_{amb}$  and RH are *added* to the measured values. For example, if the temperature observed with a high quality standard (placed close to the inlet of the blower) is 0.2K higher than the air temperature recorded by the Profiling Radiometer, then an offset of +0.2 should be entered in the field provided for the  $T_{amb}$  offset in the mp.cfg file. Because the expected difference is normally very small, it may be necessary to average the data for 1-2 hours to obtain a meaningful estimate of the bias.

<sup>4</sup> Elimination of the heater eliminates one source of locally generated error in ambient temperature and RH measurements.

## Barometric Pressure

Barometric pressure is measured with a solid-state transducer located inside the radiometer cabinet.

### Standard 600 – 1100 mb Sensor

The standard pressure sensor is rated to 600 to 1100 mb. It is a field replaceable unit (FRU), module that is located on the frame.

There are no user-adjustable controls on the sensor. However, if the sensor becomes defective, or requires recalibration by the factory, it can be easily changed. To remove the pressure sensor, locate the 2 screws on the frame that secure the housing. Remove these 2 screws to access the sensor. Use standard procedures to prevent static damage.

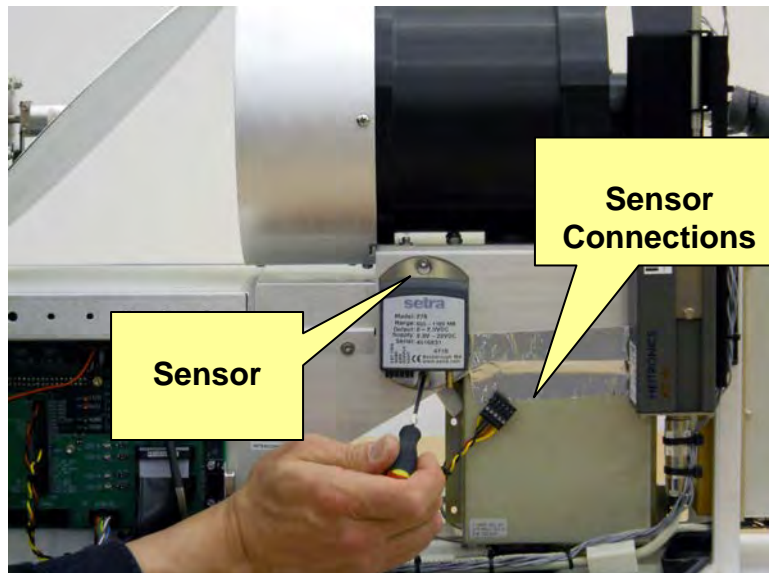
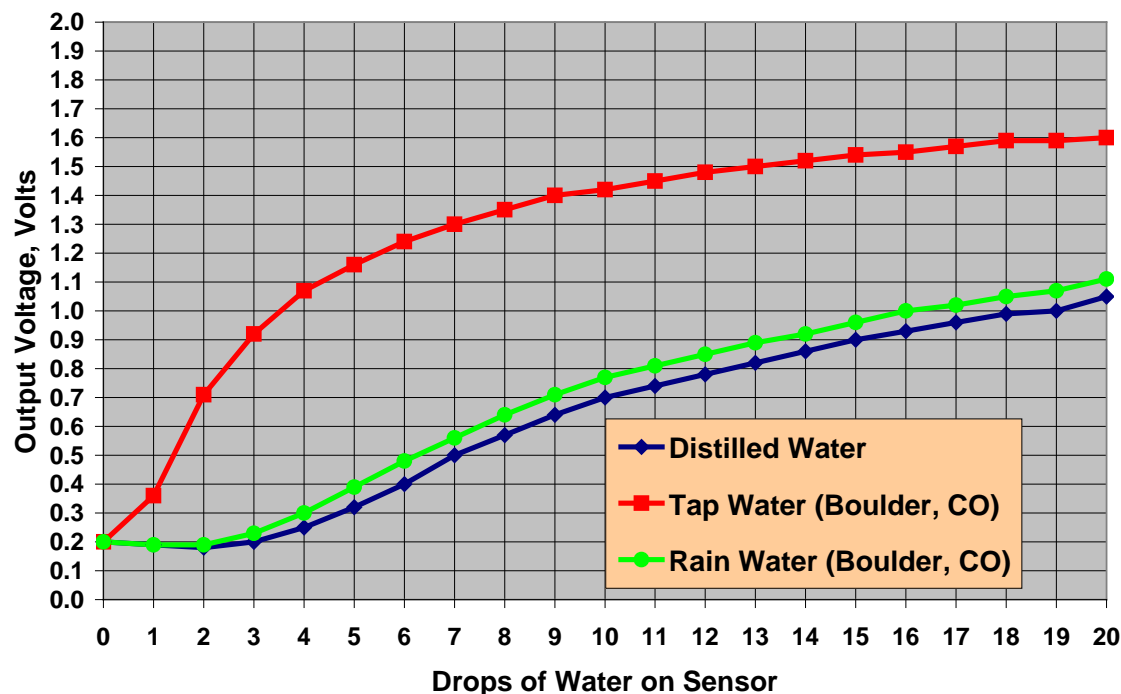

Figure E-15. Standard 600 – 1100 mb Pressure Sensor

### Rain Sensor

The Rain Sensor is an analog device that measures conductivity across a grid of interdigital, gold plated conductors etched on a conventional fiberglass circuit board. The analog output from the device varies approximately as shown in Figure E-16.

### Rain Sensor Transfer Function

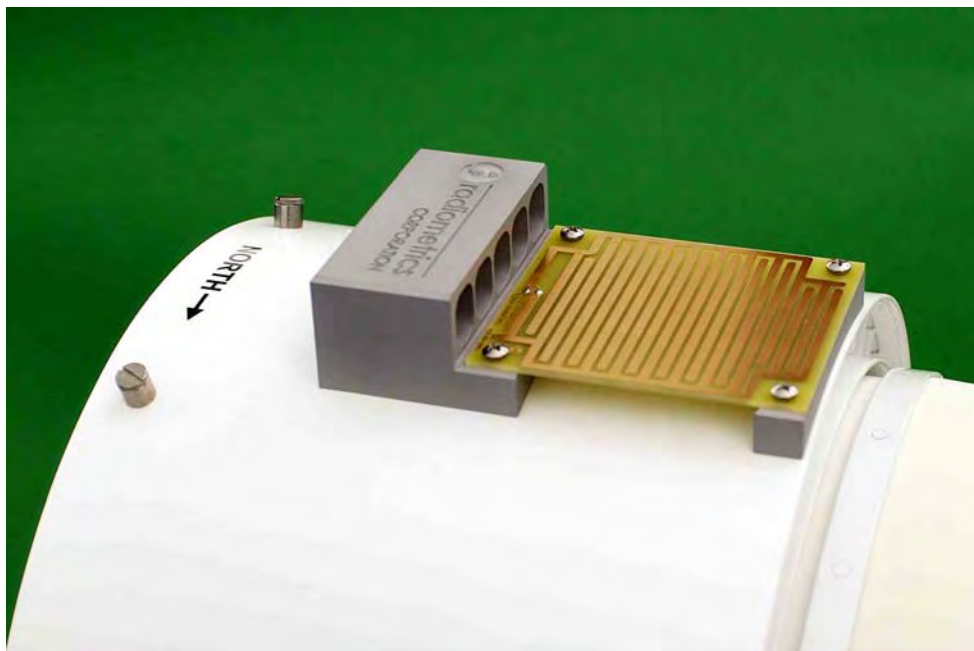

**Figure E-16. Typical Rain Sensor transfer function**

This sensor is used to provide a “Flag” for data that is potentially contaminated by some liquid water on the radome. It is not intended to provide rain rate or total rainfall information. A typical threshold setting of 0.8 volts, specified in the configuration file, is used to “turn on” the Rain Flag (1 or 0) in the *level1* and *level2* data files. The Flag is also displayed on the Profile Graphs. The Flag can also be used to suppress TIP calibrations during rain (specified in *mp.cfg*). To observe the Rain Flag in *level1* data, the Profiling Radiometer must be executing a Procedure File containing **obs** commands.

Precise calibration of the rain sensor is not necessary. The basic function can be verified by dripping a few drops of water on the sensor. When  $V_{rain} > \text{Rain Threshold}$  (set in the configuration file), the *level1* Rain Flag = “1”. Wiping the sensor dry should once again set the Rain Flag to “0”. The threshold may be adjusted by opening the configuration file in Notepad and editing the threshold value in the TIP Configuration section. Depending on the sensitivity desired and mineral content of the rain, values between ~0.6 and 1.2 volts can be used. In Figure E-16, the difference between distilled water and domestic “tap water” illustrates how mineral content affects the sensitivity.

The Rain Sensor should be wiped clean with a non-abrasive cloth or paper towel as required to keep dirt and mineral deposits from accumulating.



**Figure E-17. Rain Sensor**

### **Optional Infrared Thermometer**

When the optional KT-15 IRT is installed, it is mounted inside the cabinet, positioned to view the sky through a low-loss window in the Cabinet Hood. The IRT is connected to the MCM via the Interconnect PCB. Communication with the MCM is digital (RS232). The IRT is factory calibrated and normally requires no user calibration.

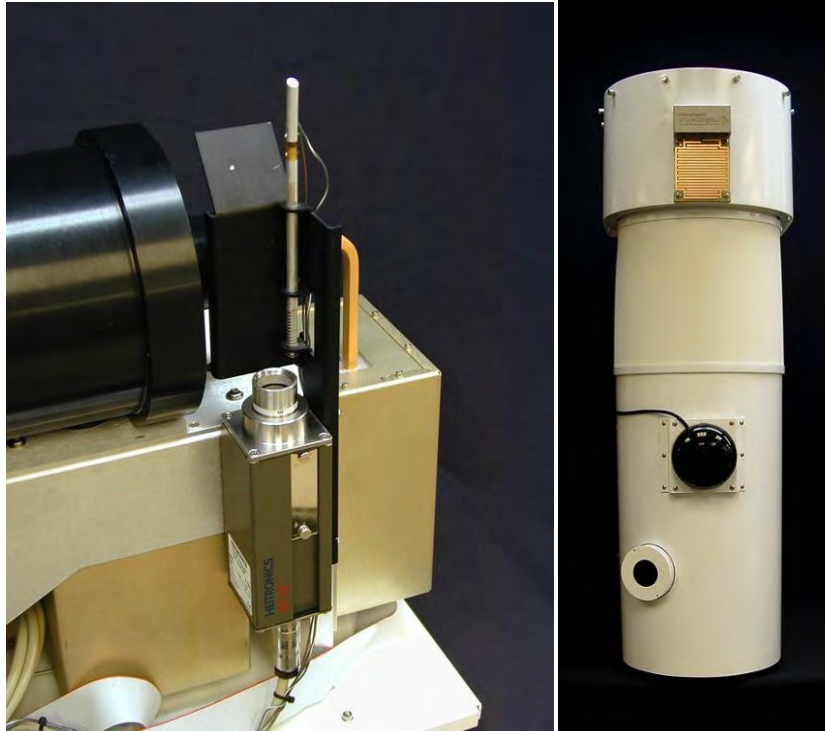

**Figure E-18. Left: KT-15 IRT Assembly; Right: Top view of Cabinet with IRT Window**

Moving the IRT inside the radiometer cabinet has several major advantages over externally mounted IRTs. Mounted inside, the KT-15 instrument is maintained in a moisture free environment, thus eliminating corrosion damage to the lens and mirror sometimes experienced on earlier radiometer models. In addition, the minimum operating temperature is extended to  $-40^{\circ}\text{C}$  without the need for supplementary heaters. The new digital interface provides a wider dynamic range and lower noise. The carbon-coated window has a longer life than gold plated mirrors, and is easily field-replaceable by simply unscrewing the old window and screwing on a new one.

To correct for the window loss and reflection errors, the IRT assembly includes two temperature sensors. One measures the window physical temperature, and the other is used to measure the temperature of a black body radiator positioned in the reflection path. The IRT computes the true cloud base temperature using these physical temperatures and factory-calibrated coefficients stored in the mp.cfg file.

# Appendix F: Cable Data

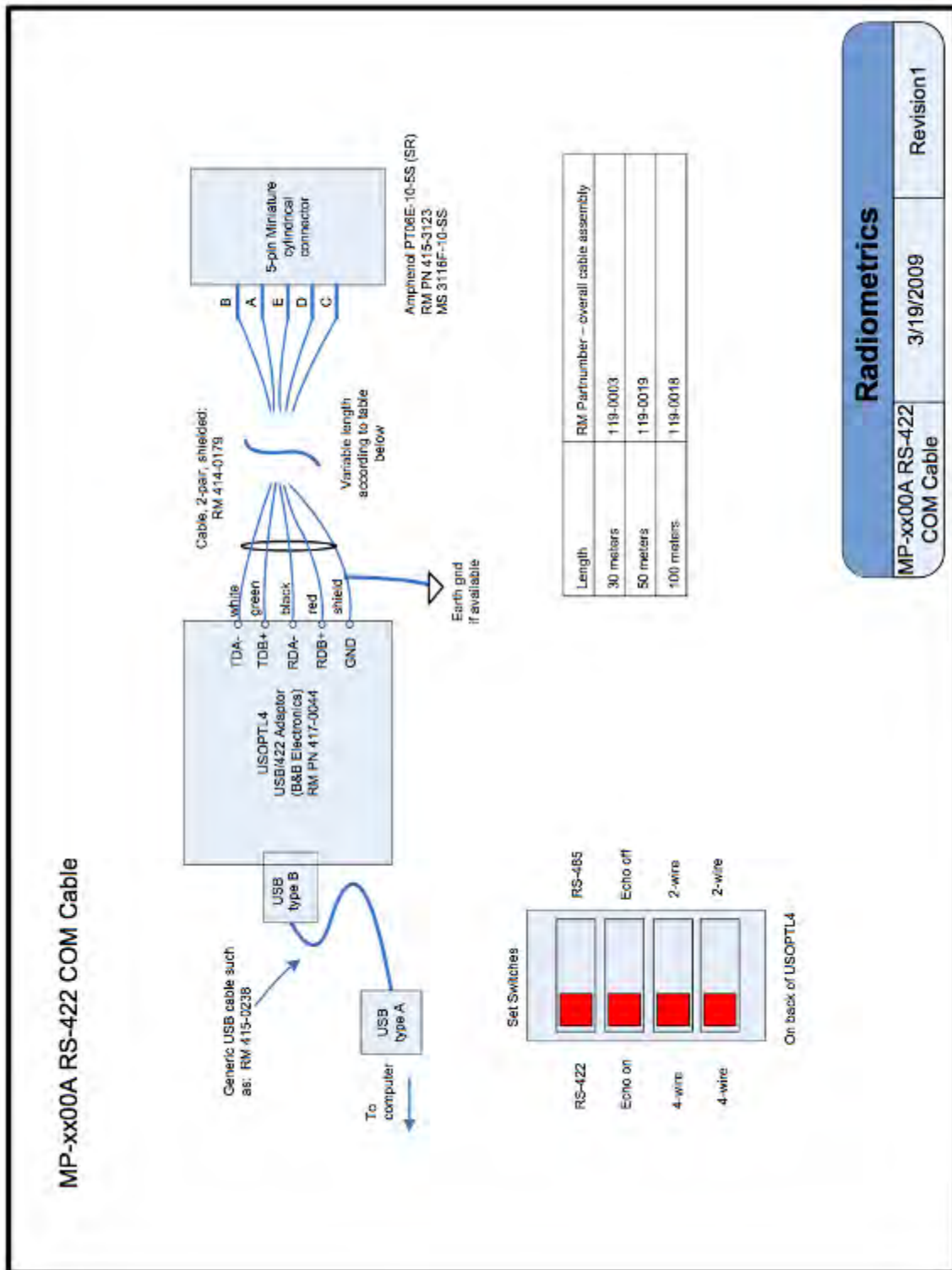

Figure F-1. RS-422 Com cable pin-out



## MP-3000A Power Interface

### Radiometer Power Cable (115VAC or 230VAC)

Cable connector: MS3116F-14-12S  
(also known as PT06E-14-12S(SR))

| Pin Connection | Mains Name | 230VAC color | 115VAC color |
|----------------|------------|--------------|--------------|
| K              | Hot        | Black        | Black        |
| M              | Neutral    | White        | White        |
| L              | Ground     | Green        | Green        |

### Superblower Power Cable (115VAC Model Only)

Cable connector: MS3116F-14-12S  
(also known as PT06E-14-12S(SR))

| Pin Connection | Mains Name | Color * |
|----------------|------------|---------|
| A              | Hot        | Black   |
| B              | Neutral    | White   |
| C              | Ground     | Green   |

\* VAC only

## Appendix G: Removal and Replacement of Common FRUs

### Overview:

This appendix describes the process of removing and installing the Field Replaceable Units (FRUs) associated with the MP-xx00A radiometer. A list of FRUs with part numbers is also provided.

While the radiometer hood is not considered an FRU, the removal/replacement process is included in this Appendix because it is a required step for replacing and installing many FRUs. Returning the radiometer to normal operation after replacing any FRU is covered in the last section of this appendix.

### Table of Contents for Appendix G:

- I. Removing and Reinstalling the Radiometer Hood
- II. Replacing the IRT Assembly
- III. Replacing the IRT Window
- IV. Replacing the MCM
- V. Replacing the Front Connector Panel Assembly
- VI. Replacing the Power Supply
- VII. Replacing the Interconnect PCBA
- VIII. Replacing the Interconnect PCBA Fuse
- IX. Replacing the S3 Temperature and R.H Sensor
- X. Replacing the HC2-S3 Ambient Air Probe
- XI. Replacing the Barometric Pressure Sensor
- XII. Replacing the Superblower
- XIII. Replacing the GPS Receiver
- XIV. Replacing the Rain Sense Board
- XV. Returning the radiometer to normal operation
- XVI. List of FRUs with Part Numbers

**NOTE:** Installers should review the entire instruction set **before** attempting the procedure described herein. Contact Radiometrics Corporation Customer Service with any questions regarding this procedure at:

- email: [support@radiometrics.com](mailto:support@radiometrics.com)
- phone: 303-539-7583

Customer Service is available from 9AM to 5PM Monday through Friday, Mountain Time.

## I. Removing and Reinstalling the Radiometer Hood

### SAFETY NOTICE

**Disconnect power to the radiometer system as described below before removing the radiometer hood.**

#### NOTE:

The radiometer hood was designed to be easy for one person to remove it, as shown in Figure G-2.

Replacing any FRU, except for the Superblower, S3 sensor, HC2-S3 probe, GPS receiver, and Rain Sense board, requires removing the radiometer hood. The process is described below and should be referenced whenever replacing an FRU that is inside the hood.

1. Stop any current procedures running on the Control Computer.
2. Turn off power to the radiometer.
3. Disconnect the Power Cable, RS-422 Cable, GPS Cable, and Superblower Cable from the radiometer Front Connector Panel.
4. Open all six latches (three per side) securing the hood to the radiometer frame. Note that once open, the latches can be reset as shown in Figure G-1, so that the bail doesn't catch on the strike when removing the hood.

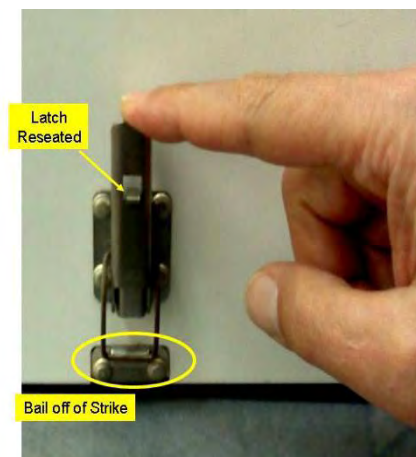
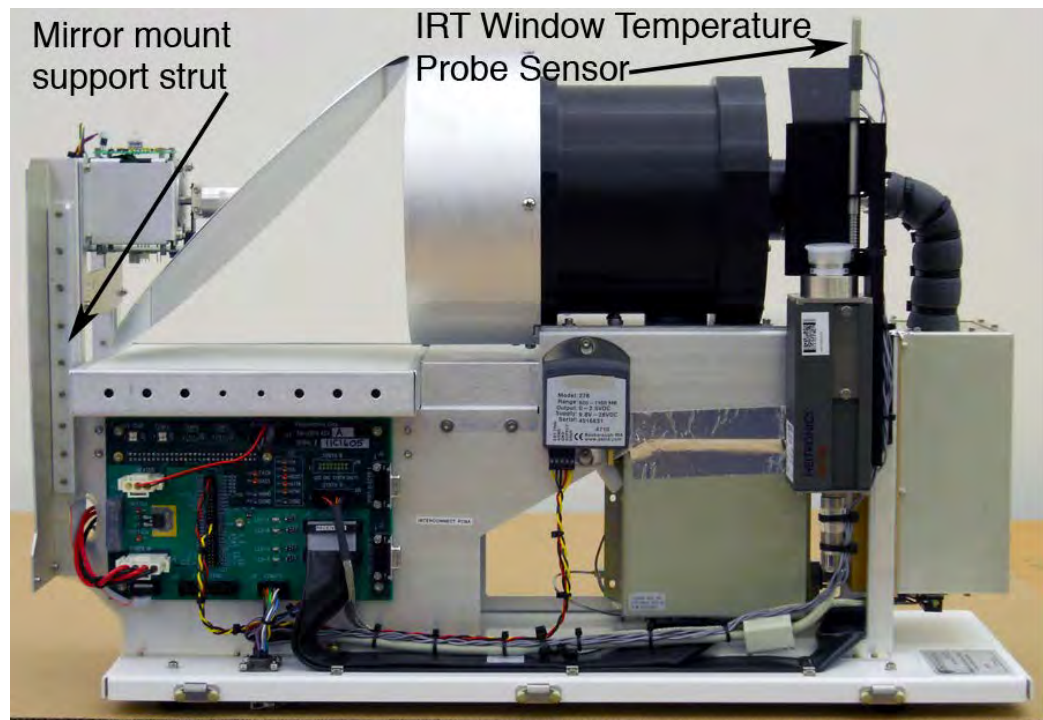

**Figure G-1. Reset the latch with the bail off of the strike**

- Using the handles at both ends of the hood, lift the hood straight up, until the bottom of the hood clears the IRT window temperature probe sensor (see Figure G-2). The IRT window temperature probe sensor is at the height of the IRT window, and can be damaged if the hood is not lifted straight up until it is clear of the probe sensor.



**Figure G-2. One person, lifting the radiometer hood straight up**



**Figure G-3. Side view of MP-3000A radiometer with hood removed**

## Reinstall the Hood & Cables

When all maintenance tasks are complete, the radiometer hood should be reinstalled. The same cautions for hood removal described above apply to hood installation.

1. Center the hood directly over the frame, being careful to avoid damage to the IRT window temperature probe sensor shown in Figure G-3.
2. Align the hood so that the latches are directly above the strikes on the frame.  
As the hood is lowered to the frame, note that there are guides inside the hood that receive the mirror motor support struts, as shown in Figure G-3.
3. Once the hood is fully seated, lock all six latches.
4. Reconnect the cables to the radiometer Front Connector Panel. The order of connection is not important. Ensure that:
  - a. The Front Connector Panel power switch is set to OFF before connecting the power cable.
  - b. The serial data cable (RS-422) connects to the **COMPUTER RS422** connector, not the **AUX RS422** connector. Note that the cable will connect to either port, but only the **COMPUTER RS422** connection is active.

## Return the Radiometer to Normal Operation

Refer to **Returning the Radiometer to Normal Operation** at the end of this Appendix.

## II. Replacing the Infrared Thermometer (IRT)

### Overview

This section provides instructions for replacing the IRT unit in an MP-xx00A series radiometer.

### Preparation

Remove the radiometer hood, as described in Section I of this Appendix.

### Special Tool Requirements:

There are only two tools required to replace the MP-3000 IRT:

- Wire cutters
- 10 mm wrench or 10 mm socket driver

### Procedure

1. After removing the radiometer hood, locate the IRT on the right side of the radiometer, as highlighted in Figure G-4.

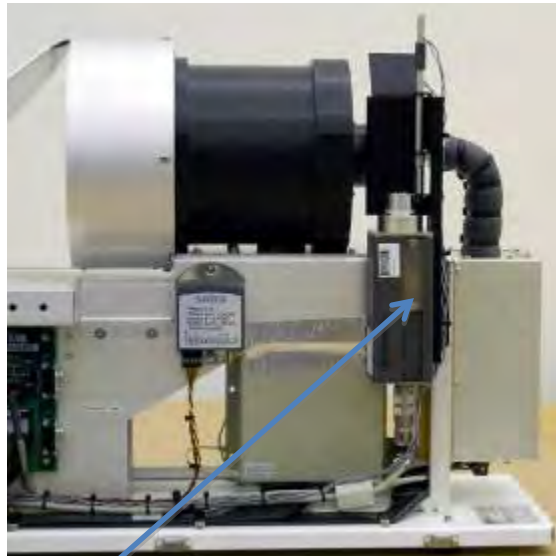

Figure G-4. IRT on right side of radiometer

- Two cable-tie retainers hold fast two thermal sensor data cable pairs. Use the wire cutters to cut the two cable-tie retainers on the IRT (Figure G-5).



**Figure G-5. Using wire cutters to remove cable-tie retainers**

- Disconnect (unscrew) the IRT from its data cable.

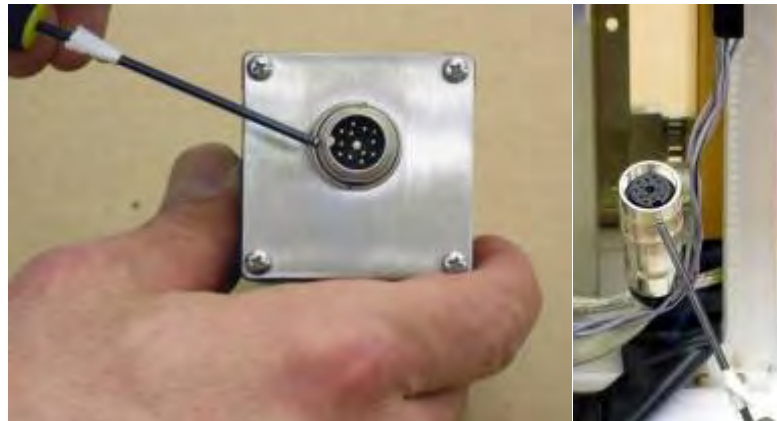

**Figure G-6. Underside of IRT, with pins (left) and IRT data/power cable harness (right)**

- Use the 10mm wrench or socket head to remove the two hex head bolts that hold the IRT to its bracket (Figure G-7), while supporting the IRT.

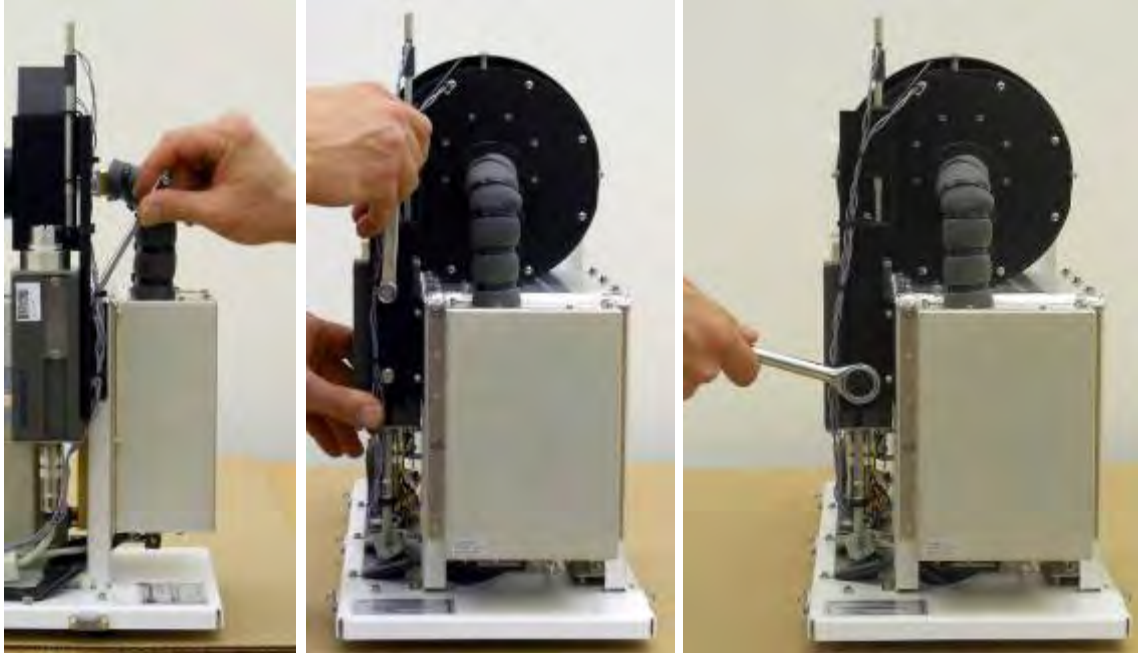

**Figure G-7. 10mm wrench (left and middle) or socket head (right) to disconnect IRT from its bracket**

5. Install replacement IRT, reversing steps 1 through 4 and remembering to use two cable-ties to retain the two pairs of thermal sensor data cable sets to the IRT's data/power cable harness (Figure G-8).



**Figure G-8. Fastening thermal sensor cable pairs with cable-tie retainers**

### **Return the Radiometer to Normal Operation**

Refer to **Returning the Radiometer to Normal Operation** at the end of this Appendix.



### III. Replacing the IRT Window Mount Cap

#### Overview

This section provides instructions for replacing the IRT Window Mount Cap for the MP-xx00A Radiometer.

#### NOTE:

Radiometrics recommends removing the hood for this procedure to avoid potential damage to the IRT probe.

#### Special Tool Requirements:

- No tools are required to perform this task, as it should only be hand tight.

#### Procedure

1. Stop any current procedures running on the Control Computer.
2. Turn off power to the radiometer.
3. Remove the radiometer hood.
4. Unscrew the IRT Window Mount cap from the IRT Window Mount Base.
5. Remove the old O-ring from the IRT Window Mount Base.

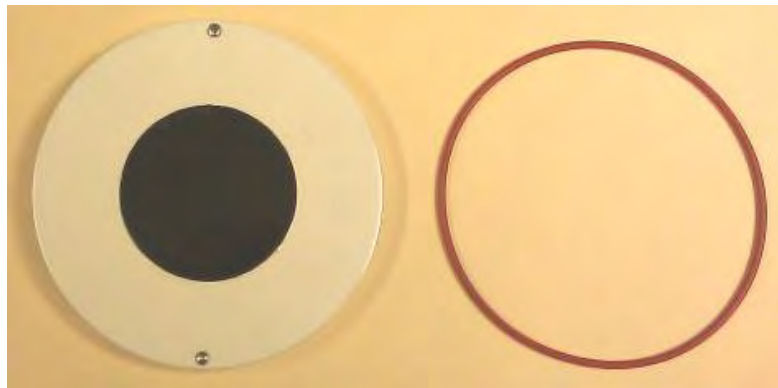

**Figure G-9. IRT window mount cap and replacement O-ring**

6. Replace the old O-ring with the new O-ring.
7. Seat the O-ring in the groove of the IRT Window Mount base.
8. Fasten the new IRT Window Mount Cap to the base, tightening it snugly by hand.

#### Return the Radiometer to Normal Operation

Refer to **Returning the Radiometer to Normal Operation** at the end of this Appendix.

## IV. Replacing the Master Control Module (MCM)

### Overview

This section provides instructions for replacing the MCM PCBA in an MP-xx00A series radiometer.

### Preparation

Remove the radiometer hood, as described in Section I of this Appendix.

### Special Tool Requirements:

- No tools are required to perform this task.

### Procedure

1. Locate the MCM PCBA, and as shown in Figure G-10 and Figure G-11.



Figure G-10. Removing radiometer hood to reveal MCM PCBA



Figure G-11. Close-up view of MCM PCBA, with two plastic latches

**NOTE:**

The following should be performed under static-control conditions. The operator should be grounded with a static-control wrist strap.

2. Pull forward the two plastic latches that secure the MCM PCBA within the card cage (Figure G-12).



**Figure G-12. Pulling release MCM PCBA latches**

3. Carefully slide the MCM PCBA out of the cage, and place on a clean, dry surface, on an anti-static mat or in an anti-static bag.
4. Slide the new MCM PCBA into the card cage. Ensure the edges of the PCBA are in the rails (see Figure G-13), and gently push the PCBA firmly into the slot so that it fully seats in the connector at the back of the card cage.



**Figure G-13. Empty card cage, showing card rails**

5. Carefully reseal the two plastic clips. Do not use force – if necessary, pull out the PCBA and reinsert.

**Return the Radiometer to Normal Operation**

Refer to **Returning the Radiometer to Normal Operation** at the end of this Appendix.

## V. Replacing the Front Connector Panel Assembly

### Overview

This section provides instructions for replacing the Front Connector Panel for the MP-xx00A Radiometer.

### Preparation

Remove the radiometer hood, as described in Section I of this Appendix.

### Special Tool Requirements:

- #1 Phillips head screwdriver
- #2 Phillips head screwdriver

### Procedure

1. Use the #1 Phillips screwdriver to remove the top three screws circled in Figure G-14 below. The remaining top screws should not be removed.

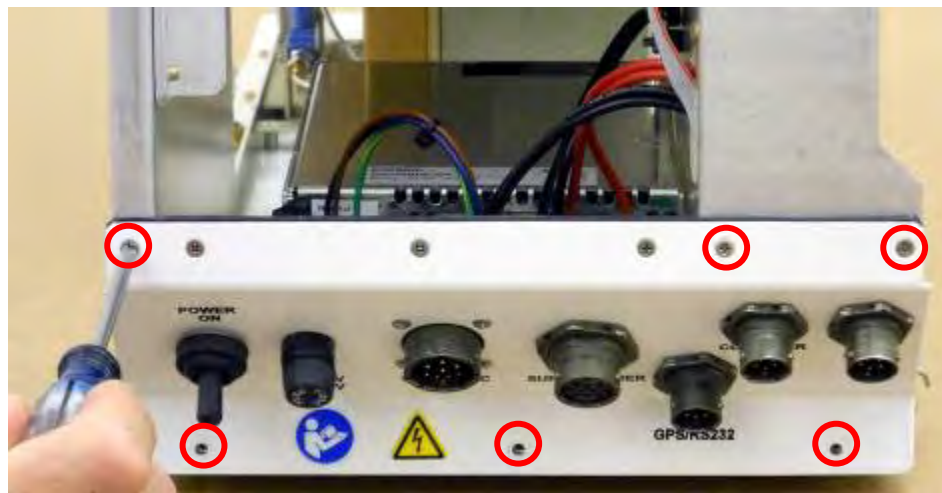

**Figure G-14. Removing Front Connector Panel**

2. Use the #2 Phillips screwdriver to remove the bottom three screws from the bottom of the Front Connector Panel, circled in Figure G-14.
3. Carefully pull the Front Connector Panel away from the frame to access the connections to the power supply.
4. To disconnect the Front Connector Panel wiring from the power supply, first remove the left-side plastic connection shield, shown in Figure G-15.

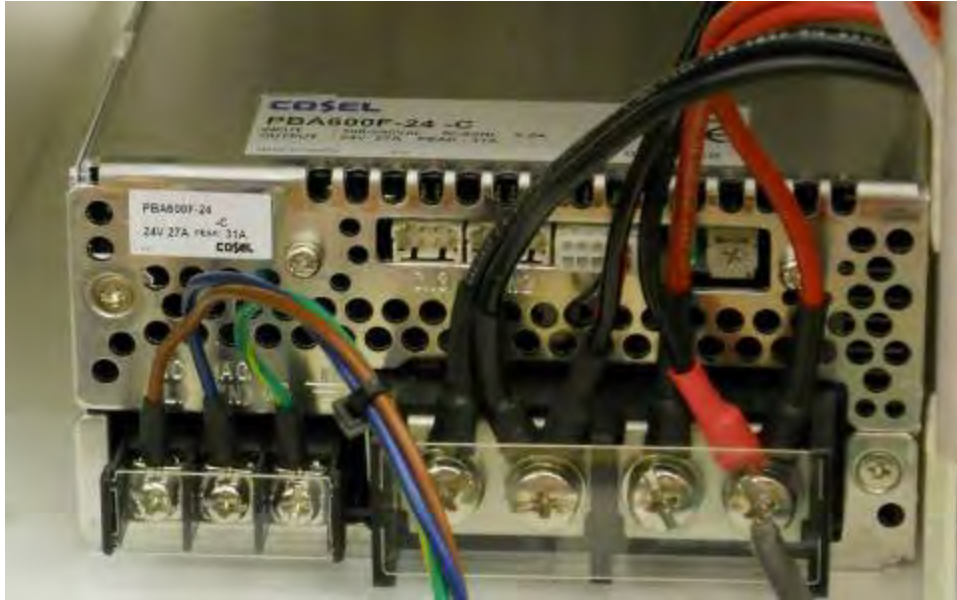

**Figure G-15. Front of Power Supply, showing two connection shields**

5. Make note of how the Power Supply's left-side wires connect:
  - Brown – left (hot line)
  - Blue – center (neutral)
  - Green/Yellow – right (chassis ground)
6. Use the #2 Philips screwdriver to loosen the screws and disconnect the wires.
7. Reverse the procedure to install the new Front Connector Panel.

### **Return the Radiometer to Normal Operation**

Refer to **Returning the Radiometer to Normal Operation** at the end of this Appendix.

## VI. Replacing the Power Supply

### Overview

This section provides instructions for replacing the Power Supply for the MP-xx00A Radiometer.

### Special Tool Requirements:

- #1 Phillips head screwdriver
- #2 Phillips head screwdriver

### Procedure

1. Remove the radiometer from the Tripod, and place the instrument on a sturdy workbench or other clean work surface.
2. Remove the radiometer hood as described in Section I of this Appendix.
3. Remove the radiometer Front Connector Panel as described in Section V of this Appendix.
4. Make note of how the Power Supply's right-side wires connect, as shown in Figure G-16.
  - Two singles – Fan
  - Two pairs – Interconnect PCBA

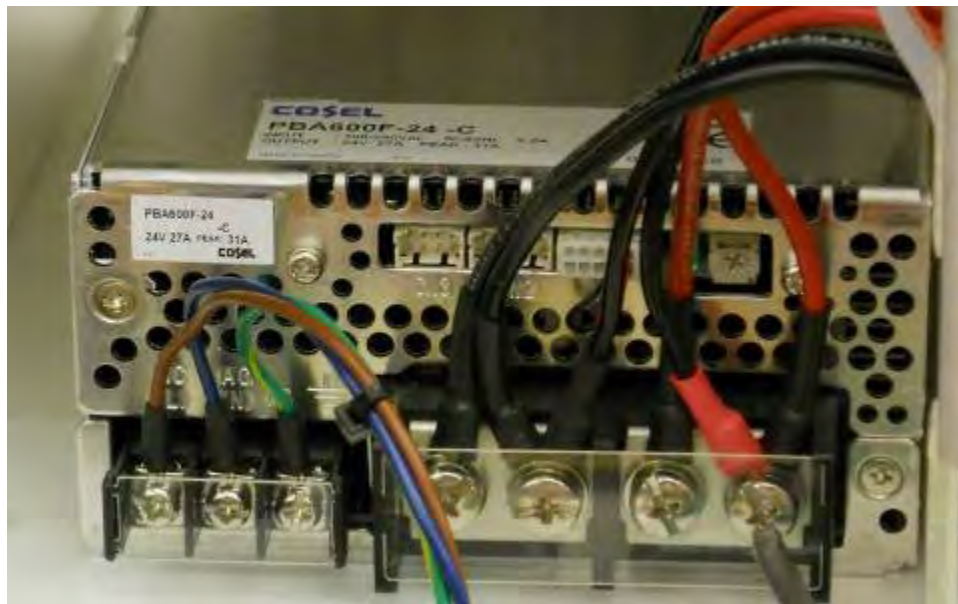

**Figure G-16. Front of Power Supply, showing two connection shields**

5. Use the #2 Philips screwdriver to disconnect the wires. Note that these are a screw/lock washer/flat washer combination.



**Figure G-17. Screw/lock washer/flat washer combination**

6. To remove the power supply, carefully turn the radiometer on its side, with the IRT facing upward.
7. Use the #2 Phillips screwdriver to remove the radiometer Mounting Plate, and then detach the power supply from the frame by removing the four screws highlighted in Figure G-18. Note that one hand should be used to hold the power supply in place when removing these screws.
8. Remove the Power Supply from the radiometer.
9. Install the replacement Power Supply, reversing steps 1 thru 7.

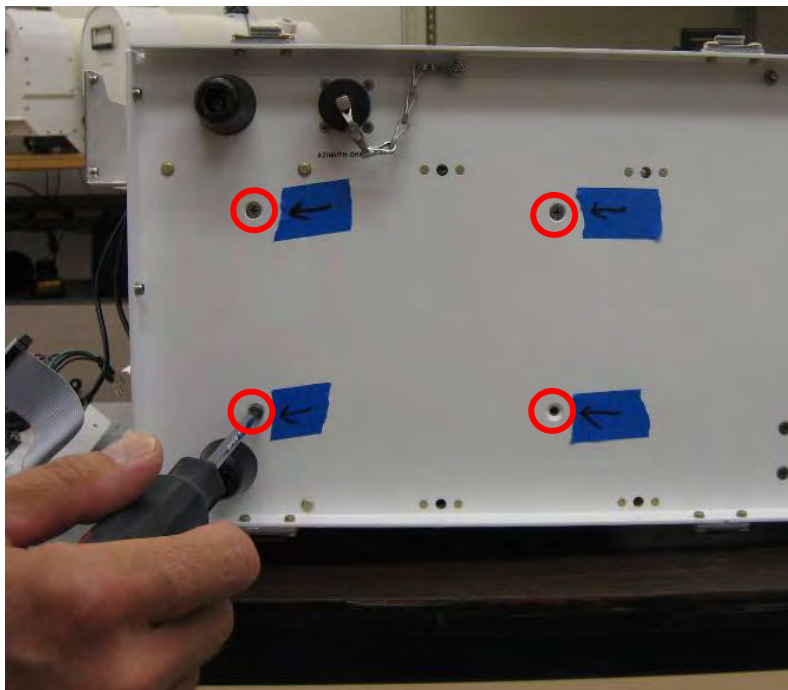

**Figure G-18. Power Supply mounting screws**

### **Return the Radiometer to Normal Operation**

Refer to **Returning the Radiometer to Normal Operation** at the end of this Appendix.

## VII. Replacing the Interconnect PCBA

### Overview

This section provides instructions for replacing the Interconnect PCBA for the MP-xx00A Radiometer.

### Preparation

Remove the radiometer hood, as described in Section I of this Appendix.

### Special Tool Requirements:

- 7/64" socket driver

### Procedure

1. Position the radiometer to clearly see the Interconnect PCBA, shown in Figure G-19 below.

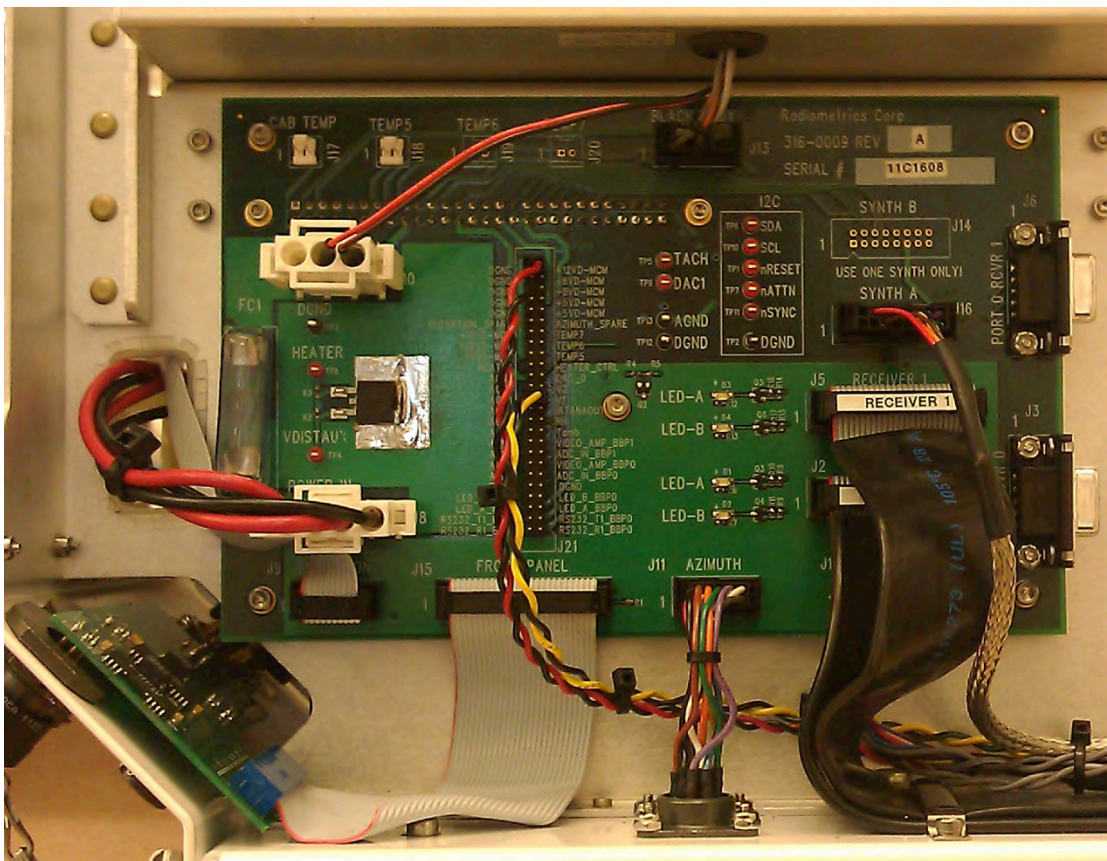
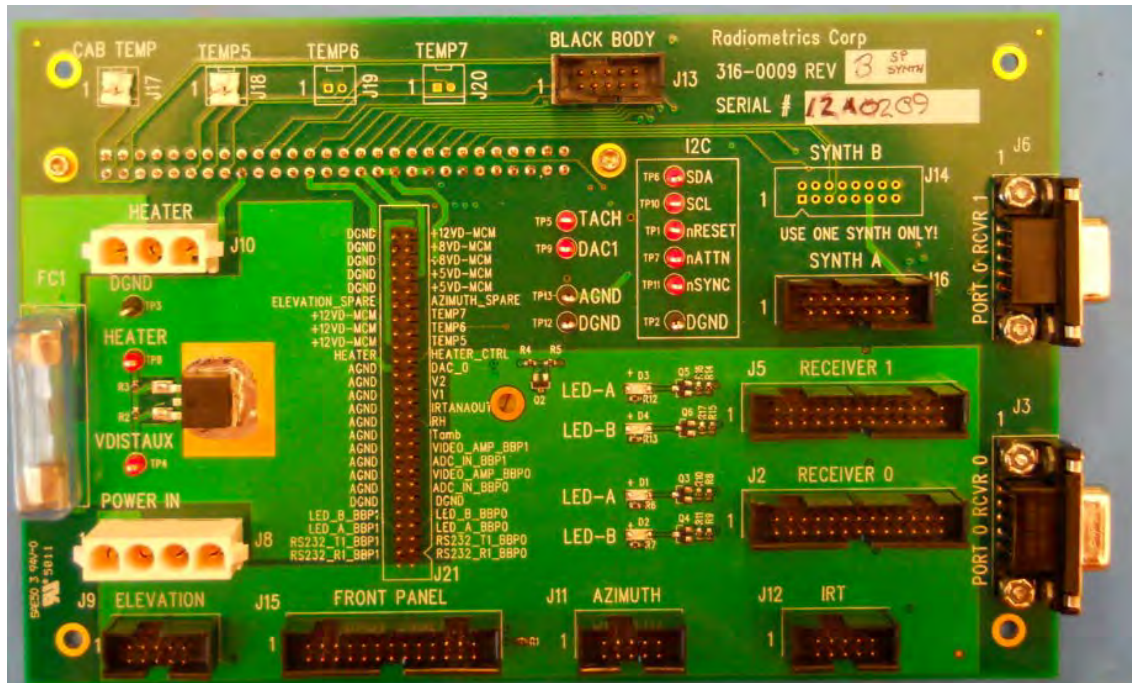

**Figure G-19. Interconnect PCBA; note all the connections**

2. Carefully note the connection for each cable. See Figure G-19.

For reference, a close-up image of the Interconnect PCBA without cables attached is shown in Figure G-20.





**Figure G-20. Interconnect PCBA with no cables attached**

3. Disconnect all ten connections to the Interconnect PCBA:

- AZIMUTH — J11
- Barometer connections: two twisted pairs. Refer to Figure G-21.
  - power to — V1 (Yellow/Black cable)
  - signal from — +12VD-MCM (Red/Black cable)
- BLACK BODY — J13
- ELEVATION — J9
- Fan power (labeled as HEATER) — J10
- FRONT CONNECTOR PANEL (for communication) — J15
- IRT — J12
- POWER IN (24V) — J8
- RECEIVER0 — J2
- RECEIVER 1 — J5
- Synth A (signal for both receivers)

4. Use the 7/64" socket driver to remove the five retaining screws:

- Four 3/8-inch 6-32 socket head cap screws in the corners
- One 3/4-inch 6-32 socket head cap screw in the center

5. Remove the Interconnect PCBA from the radiometer.
6. Install the replacement Interconnect PCBA, reversing steps 1 through 4.



**Figure G-21. Close up detail of connections +12VD and V1**

### **Return the Radiometer to Normal Operation**

Refer to **Returning the Radiometer to Normal Operation** at the end of this Appendix.

## VIII. Replacing the Interconnect PCBA Fuse

### Overview

This section provides instructions for replacing the Interconnect PCBA Fuse for the MP-xx00A Radiometer.

### Preparation

Remove the radiometer hood, as described in Section I of this Appendix.

### Special Tool Requirements:

- 7/64" socket driver
- Fuse: 32V 3AG 12A (Radiometrics part number 419-0014)

### Procedure

1. Position the radiometer to clearly see the Interconnect PCBA, shown in Figure G-22 below.

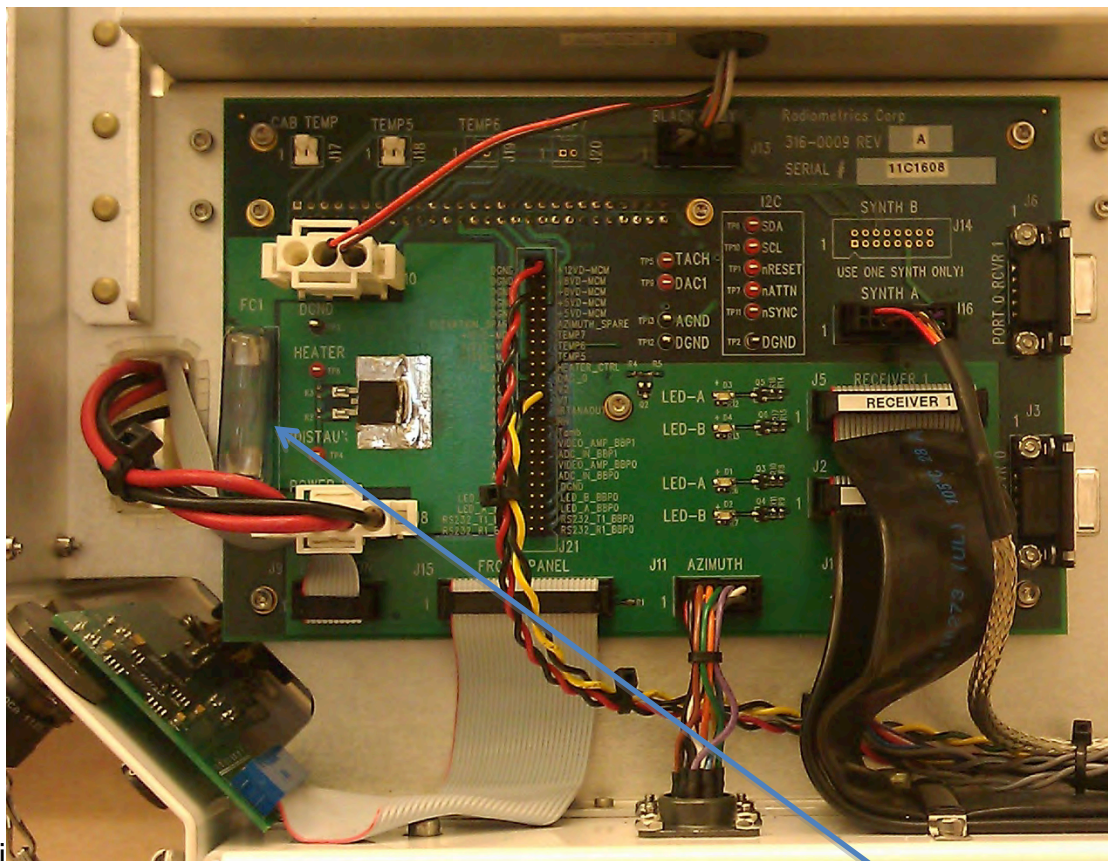

Figure G-22. Interconnect PCBA; note position of Fuse

2. Locate the PCBA Fuse on the left side of the PCBA (labeled FC1).
3. Carefully pull off the Fuse Cover and remove the Fuse. (User may use a small flat-head screwdriver to pry the Fuse Cover upward.)
4. Replace the Fuse with the part specified above, and replace the Fuse Cover.

### **Return the Radiometer to Normal Operation**

Refer to **Returning the Radiometer to Normal Operation** at the end of this Appendix.

## IX. Replacing the S3 Temperature and RH Sensor

### Overview

This section provides instructions for replacing the S3 Temperature and RH Sensor for the MP-xx00A Radiometer. For maintenance information on sensor screen removal and cleaning, refer to section 6.1.5 of the **Radiometrics Profiler Operator's Manual**.

### NOTE:

It is not required that the radiometer hood be removed for this procedure.

### Special Tool Requirements:

- A straight-bladed screwdriver might be required to loosen the thumbscrews.

### Procedure

1. Stop any current procedures running on the Control Computer.
2. Turn off power to the radiometer.
3. Remove the Superblower front panel.

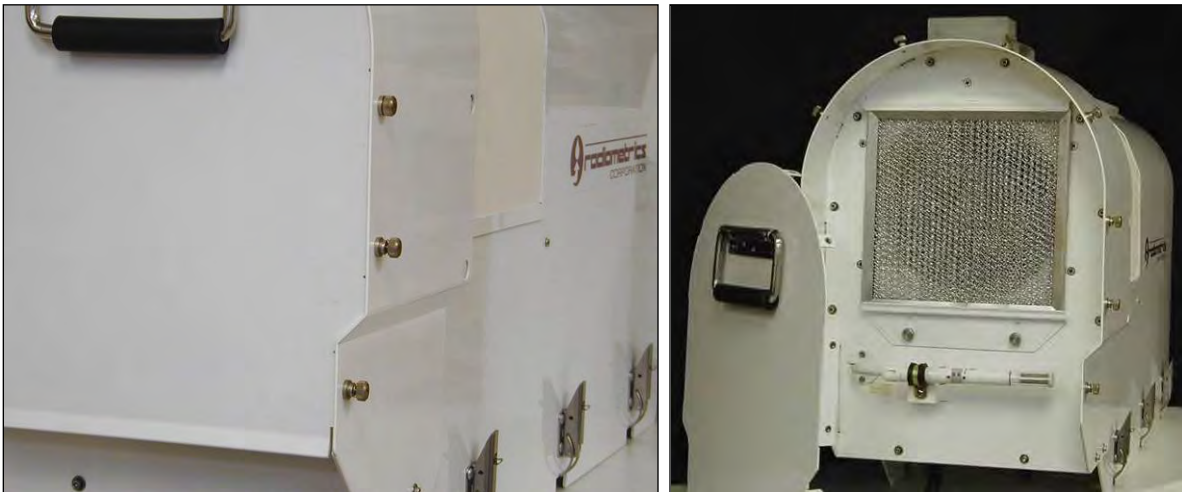

**Figure G-23. Loosened thumbscrews on Superblower cover; cover removed (right)**

4. Rotate the gray locking collar that holds the sensor to the probe arm, until the black dots align, and pull sensor to the right remove.

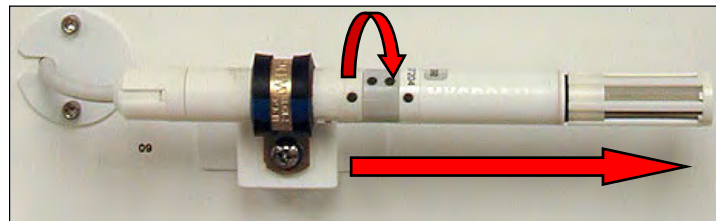

**Figure G-24. S3 Sensor removal**

5. Make note of how the probe pins align with the receptors, as shown below in Figure G-25.



**Figure G-25. S3 Temperature and RH Sensor, showing receptors**

6. Replace the S3 Temperature and RH Sensor, reversing the steps 1 thru 4.

### **Return the Radiometer to Normal Operation**

Refer to **Returning the Radiometer to Normal Operation** at the end of this Appendix.

## X. Replacing the HC2-S3 Ambient Air Probe

### Overview

This section provides instructions for replacing the HC2-S3 Ambient Air Probe for the MP-xx00A Radiometer. For maintenance information on sensor screen removal and cleaning, refer to section 6.1.5 of the **Radiometrics Profiler Operator's Manual**.

### NOTE:

It is not required that the radiometer hood be removed for this procedure.

### Special Tool Requirements:

- A straight-bladed screwdriver might be required to loosen the thumbscrews.

### Procedure

1. Stop any current procedures running on the Control Computer.
2. Turn off power to the radiometer.
3. Remove the Superblower front panel.

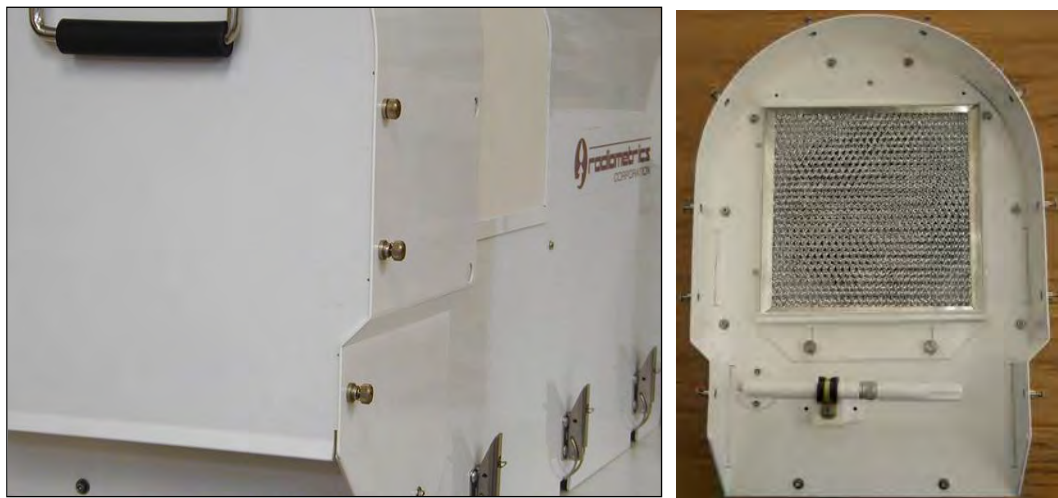

**Figure G-26. Loosened thumbscrews on Superblower cover;  
cover removed (right)**

4. Loosen the locking metal collar that holds the air probe to the probe arm, and pull probe to the right to remove.

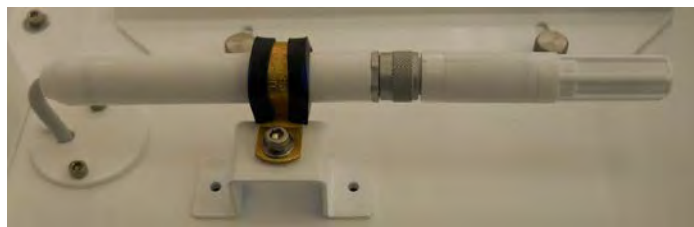

**Figure G-27. HC2-S3 probe removal**

5. Make note of how the probe pins align with the receptors, as shown below in Figure G-28.



**Figure G-28. HC2-S3 Ambient Air Probe, showing receptors**

6. Replace the HC2-S3 Ambient Air Probe, reversing the steps 1 thru 4.

### **Return the Radiometer to Normal Operation**

Refer to **Returning the Radiometer to Normal Operation** at the end of this Appendix.



## XI. Replacing the Barometric Pressure Sensor

### Overview

This section provides instructions for replacing the Barometric Pressure Sensor unit in an MP-xx00A series radiometer.

### Preparation

Remove the radiometer hood, as described in Section I of this Appendix.

### Special Tool Requirements:

- 7/64" hex driver

### Procedure

1. After removing the radiometer hood, locate the Barometric Pressure Sensor on the right side of the radiometer, as shown in Figure G-29.



**Figure G-29. Pressure Sensor on right side of radiometer**

2. Disconnect the data/power cable from the Barometric Pressure Sensor by grasping the connector housing and pulling downward (Figure G-30).



**Figure G-30. Cable to Pressure Sensor, disconnected (right)**

3. Use the 7/64" hex driver to remove the two socket head cap screws (older models: 4-40 x 3/8"; newer models: 6-32 x 3/8") holding the Pressure Sensor to the frame (Figure G-31).



**Figure G-31. Detaching Pressure Sensor from its frame**

4. Remove the pressure sensor from the radiometer.
5. Install replacement Barometric Pressure Sensor, reversing steps 1 thru 3.

### **Return the Radiometer to Normal Operation**

Refer to **Returning the Radiometer to Normal Operation** at the end of this Appendix.

## XII. Replacing the Superblower

### Overview

This section provides instructions for replacing the Superblower for the MP-xx00A Radiometer.

### NOTE:

It is recommended that the radiometer hood be removed for this procedure. It is easier to put just the radiometer hood on its end, instead of the entire radiometer.

### Preparation

Remove the radiometer hood, as described in Section I of this Appendix.

### Special Tool Requirements:

- #2 Phillips head screwdriver

### Procedure

1. Place the radiometer hood on a workbench, with the Superblower facing upward, as in Figure G-32.

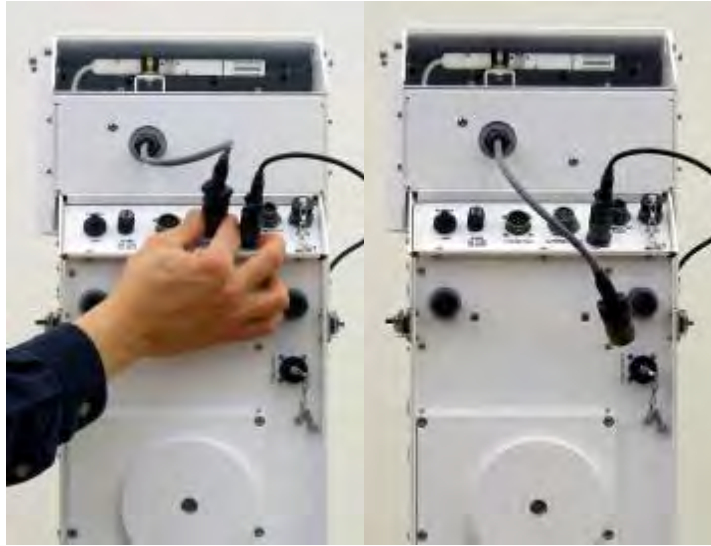

**Figure G-32. Radiometer hood on workbench**

If necessary, the Superblower can be removed with the instrument on the Tripod. The procedure requires two people:

- one person to hold the Superblower in place, while
- the second person removes/reinstalls screws

2. Disconnect the Superblower cable from the Front Connector Panel.



**Figure G-33. Disconnecting Superblower cable / cable disconnected**

3. Use the #2 Phillips screwdriver to remove the four screws (8-32 x 1/2" Phillips pan head screws) and flat washers from the Superblower. Note the access holes in the side of the Superblower in Figure G-34.



**Figure G-34. Removing Superblower screws (two on each side)**

4. Use the handle and front face to lift the Superblower upward and separate it from the radiometer.



**Figure G-35. Lifting Superblower away from the radiometer hood**

5. Install replacement Superblower, reversing steps 1 thru 4.

### **Return the Radiometer to Normal Operation**

Refer to **Returning the Radiometer to Normal Operation** at the end of this Appendix.

### **XIII. Replacing the GPS Receiver**

#### **Overview**

This section provides instructions for replacing the GPS Receiver for the MP-xx00A Radiometer.

#### **NOTE:**

Do not remove the radiometer hood for this procedure.

#### **Special Tool Requirements:**

- #2 Phillips head screwdriver

#### **Procedure**

1. Stop any current procedures running on the Control Computer.
2. Turn off power to the radiometer.
3. Disconnect the GPS Receiver cable from the radiometer Front Connector Panel.

The GPS Receiver cable is fastened to the radiometer hood with two P-clips.

4. Use the #2 Philips screwdriver to disconnect the two P-clips from the radiometer hood (two 8-32 x 3/8" pan head screws with flat washers,).

The GPS Receiver is attached to a GPS Mounting Plate (shown in Figure G-36) that is attached to a bracket on the radiometer hood.

5. Use the #2 Phillips screwdriver to disconnect the GPS Mounting Plate from the bracket on the radiometer hood (four Phillips 6-32 x3/8" round head screws with flat washers).

The bottom side of the GPS receiver is attached to the GPS Mounting Plate, as shown in Figure G-36

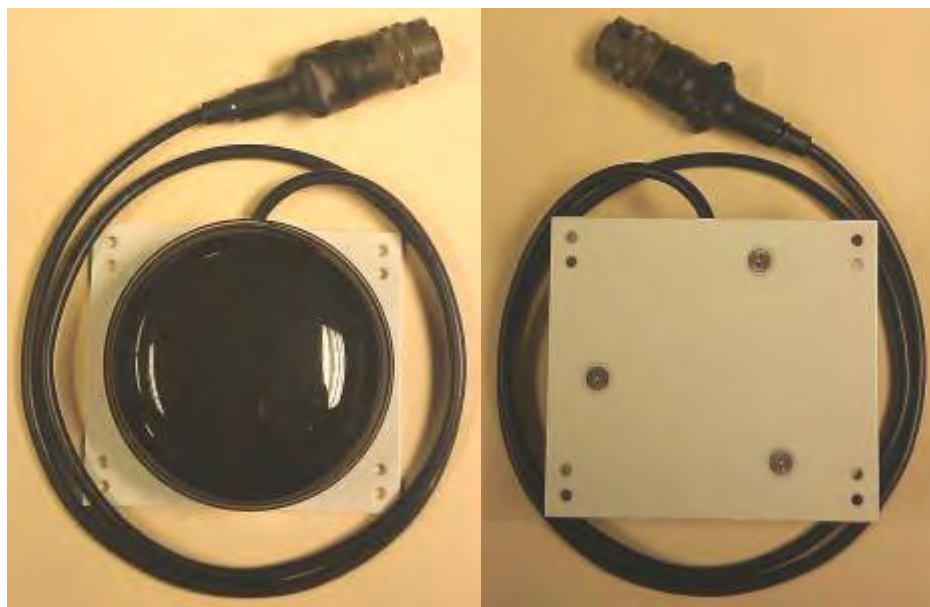

**Figure G-36. GPS receiver attached to GPS Mounting Plate with three screws (right)**

6. Use the #2 Phillips screwdriver to remove the GPS Mounting Plate from the GPS receiver (three metric M4 x 6mm flathead screws).
7. Install replacement GPS receiver, reversing steps 1 thru 4.

### **Return the Radiometer to Normal Operation**

Refer to **Returning the Radiometer to Normal Operation** at the end of this Appendix.

## XIV. Replacing the Rain Sense PCBA

### Overview

This section provides instructions for replacing the Rain Sense PCBA for the MP-xx00A Radiometer.

### NOTE:

Do not remove the radiometer hood for this procedure.

### Special Tool Requirements:

- #2 Phillips head screwdriver

### Procedure

1. Stop any current procedures running on the Control Computer.
2. Turn off power to the radiometer.
3. Use the #2 Philips screwdriver to disconnect the Rain Sense PCBA from the radiometer hood (four 6-32 x 3/8" pan head screws with flat washers).
4. Disconnect the cable to the radiometer from Rain Sense PCBA (Figure G-37).

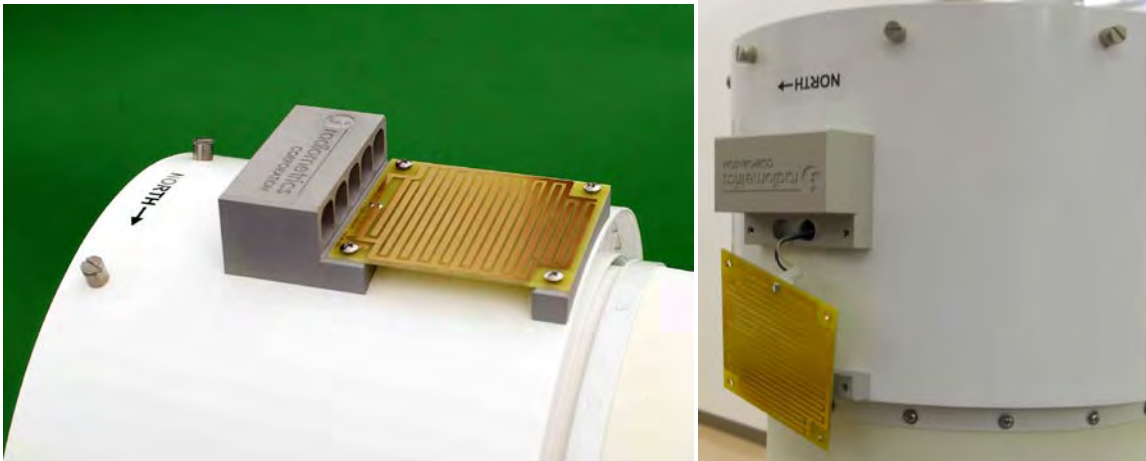

**Figure G-37. Rain Sense PCBA, detached and showing cable on the right**

7. Connect cable to the replacement Rain Sense PCBA (part number 316-0005).
8. Install the replacement Rain Sense PCBA, reversing steps 1 thru 4.

### Return the Radiometer to Normal Operation

Refer to **Returning the Radiometer to Normal Operation** at the end of this Appendix



## XV. Returning the Radiometer to Normal Operation

1. Turn on the radiometer power switch. The blower fan should start, and the mirror motor movement should be audible during its self-test.
2. Power on the Control Computer.
3. Open VizMet-B and on the **Status/Control** tab, start the desired procedure. Monitor the tab for several minutes to ensure the desired procedure starts normally.
4. If the procedure does not start up normally, perform the following troubleshooting steps:
  - a. Ensure the radiometer is powered on.
  - b. Verify that the RS-422 data cable is connected to the **COMPUTER RS422** port on the radiometer Front Connector Panel, and not the **AUX RS422** port.
  - c. If the radiometer Superblower is not running (blowing air over the Radome), turn off power and check the Front Connector Panel fuse.
  - d. Repeat the process described above to remove the hood and ensure the connections to the power supply are correct and secure.
9. If none of these steps correct the problem, contact Radiometrics Customer Service for additional support.

## XVI. List of FRUs with Part Numbers

| <b>Part No.</b> | <b>Description</b>                             |
|-----------------|--|
| 317-0007        | 24V Power Supply                               |
| 327-0004        | IRT Window Assembly                            |
| 319-0002        | Front Connector Panel Assembly                 |
| 217-0001        | GPS Receiver Assembly                          |
| 119-0003        | RS-422 Data Cable Assembly, 30 m               |
| 417-0008        | S3 Temperature and R.H. Sensor                 |
| 229-0013        | Superblower Assembly                           |
| 316-0005        | Rain Sense PCBA                                |
| 119-0001        | Power Cable Assembly, 30 m                     |
| 316-0013        | Master Control Module (MCM)                    |
| 417-0044        | RS-422 to USB Adapter                          |
| 316-0009        | Interconnect PCBA                              |
| 229-0002        | IRT Assembly                                   |
| 419-0031        | Barometer                                      |
| 417-0119        | HC2-S3   |
| 229-0015        | 110VAC Superblower                             |
| 423-0010        | Aluminum Mesh Filter                           |
| 129-0004        | Coated Hydrophobic Radome, 1-pack <sup>5</sup> |
| 129-0003        | Coated Hydrophobic Radome, 2-pack <sup>5</sup> |
| 129-0006        | Coated Hydrophobic Radome, 4-pack <sup>5</sup> |
| 419-0015        | Fuse, 6 Amp, 100-127V <sup>6</sup>             |
| 419-0012        | Fuse, 3 Amp, 220 -240V <sup>6</sup>            |

---

<sup>5</sup> See Section 6.1.4 of the Profiler Operator's Manual for information on replacing the Radome.

<sup>6</sup> Located on the Front Connector Panel, refer to the figure in Section 3.9 of the Profiler Operator's Manual for fuse location. Use appropriate fuse for commercial voltage.

This page left intentionally blank.

## Appendix H: Azimuth Positioner Installation and Removal

### Definitions

#### **Azimuth Positioner**

The Azimuth Positioner is an optional radiometer accessory used to point the radiometer to a specific azimuth defined by the user. The Azimuth Positioner is mounted on the bottom of the radiometer and connects to the Tripod with a T-Bolt.

#### **Radiometer Mounting Plate**

The radiometer Mounting Plate is attached to the bottom of the radiometer and provides the means to secure the radiometer to the Tripod with a T-Bolt. The radiometer Mounting Plate is not used when the optional Azimuth Positioner accessory is installed.

### Introduction

All radiometers are supplied with a radiometer Mounting Plate as part of the standard equipment. The radiometer Mounting Plate provides the means of securing the radiometer to a Tripod or other mounting platform. Users who have purchased an Azimuth Positioner must first remove the radiometer Mounting Plate (if installed) before installing the Azimuth Positioner. Users who have purchased the optional Azimuth Positioner should not discard the radiometer Mounting Plate, but they should instead store it in the Reusable Shipping Container.

Note: Customers who require additional assistance should contact **Radiometrics Customer Service**: [support@radiometrics.com](mailto:support@radiometrics.com)

#### **Azimuth Positioner Installation Kit Contents**

The following items are supplied for installation of the Azimuth Positioner on all A-Series radiometers:

- Azimuth Positioner, part number 129-0009
- Qty. six 10-32 x 3/4" socket head cap screw, part number 421-3034

**NOTE:**

Radiometers are typically shipped with the radiometer Mounting Plate (part number 423-3005) pre-installed to the bottom of the radiometer. When a radiometer is purchased with the optional Azimuth Positioner, the radiometer Mounting Plate will **not** typically be attached to the bottom of the radiometer. In these instances, the mounting hardware for the radiometer Mounting Plate will be located inside a plastic bag secured to the radiometer Mounting Plate. **The mounting hardware to secure the radiometer Mounting Plate to the radiometer is the same as the hardware used to secure the Azimuth Positioner.**

To install a radiometer Mounting Plate, the following are required:

- a. Radiometer Mounting Plate, part number 423-3005.
- b. Qty. six 10-32 x 3/4" Socket head cap screws, part number 421-3034.

**Installation Tool and Parts Requirements**

To install or remove either the radiometer Mounting Plate or an Azimuth Positioner, the installer performing the installation (or removal) will need the following tools and parts:

- Qty. one, 5/32" hex L-key or ball driver (supplied in the radiometer Tool Kit)
- Qty. six, 10-32 x 3/4" Socket head cap screws, part number 421-3034

**Installing the Azimuth Positioner**

1. If the Mounting Plate is already installed on the radiometer, it must be removed before the azimuth positioner can be installed:
  - a. If the radiometer is in operation:
    - i. Stop any current procedures running on the Control Computer
    - ii. Turn off power to the radiometer
    - iii. Disconnect power and data cable
    - iv. Remove the radiometer from the Tripod
  - b. Place the radiometer on a workbench, with the Superblower facing upward, as shown in Figure H-2.
  - c. Locate the six mounting holes used to secure the radiometer Mounting Plate.
  - d. Remove the six 10-32 x 3/4" socket head cap screws (part number 421-3034).



**Figure H-1. Underside view of radiometer with Mounting Plate**

2. If the Mounting Plate is not installed, place the radiometer on a workbench, with the Superblower facing upward.
3. Locate the six mounting holes on the underside of the radiometer (these are the same mounting holes used with Mounting Plate). For reference, see Figure G-1.
4. Use six 10-32 x 3/4" socket head cap screws to secure the Azimuth to the bottom of the radiometer, as shown in Figure G-2.
5. On the bottom of the radiometer, connect the Azimuth Positioner Interface Cable to the connector receptacle labeled **AZIMUTH DRIVE**, as shown in Figure H-2.



**Figure H-2. Underside of radiometer with Azimuth Drive installed**

**NOTE:**

If the Azimuth Positioner Interface Cable is removed from the radiometer, attach the Cap to the **AZIMUTH DRIVE** connector receptacle on the bottom of the radiometer to prevent debris from entering the connector receptacle.

6. Refer to the **Radiometrics Profiler Operator's Manual** (supplied with the radiometer) for additional information on the operation of the Azimuth Positioner.
7. Mount the radiometer to the Tripod or other mounting platform using the T-Bolt supplied with the radiometer. **Make certain the T-Bolt is tight.**
8. Reconnect all power and communication cables and turn the radiometer power switch "On". The radiometer will move on the Tripod upon recognition of the Azimuth Positioner.
9. After all motions have stopped, slightly loosen the T-Bolt and rotate the radiometer so that the Superblower faces East (see **Radiometrics Profiler Operator's Manual**).
10. Retighten the T-Bolt.

## Removing the Azimuth Positioner and Installing the Mounting Plate

### NOTE:

After the Azimuth Positioner is removed, install the Mounting Plate onto the radiometer to be able to mount it to the Tripod.

1. Stop any current procedures running on the Control Computer.
2. Turn off power to the radiometer.
3. Disconnect power and data cables.
4. Loosen the T-Bolt and remove the radiometer from the Tripod.
5. Place the radiometer on a workbench, with the Superblower facing upward, as shown in Figure H-2.
6. Disconnect the Azimuth Drive positioner cable.
7. Locate the six mounting holes used to secure the Azimuth Positioner.
8. Remove the six 10-32 x 3/4" socket head cap screws (part number 421-3034).
9. Use the same six mounting holes and six 10-32 x 3/4" socket head cap screws (as those used to mount the Azimuth Positioner) to secure the Mounting Plate (part number 423-3005) to the bottom of the radiometer, as shown in Figure H-1.
10. If the Azimuth Positioner Interface Cable is removed from the radiometer, attach the Cap to the **AZIMUTH DRIVE** connector receptacle on the bottom of the radiometer to prevent debris from entering the connector receptacle.
11. Refer to the **Radiometrics Profiler Operator's Manual** (supplied with the radiometer) for additional information on the operation of the Azimuth Positioner.
12. Mount the radiometer to the Tripod or Quadpod using the T-Bolt supplied with the radiometer. **Make certain the T-Bolt is tight.**
13. Reconnect all power and communication cables and turn the radiometer power switch to **ON**.



This page left intentionally blank.

## Appendix I: Specifications, Weights and Dimensions

| Function or Parameter   | Specification                                    |
|---|--|
| Calibrated Brightness Temperature Accuracy <sup>7</sup>               | $0.2 + 0.002 *  T_{kBB} - T_{sky} $ <sup>8</sup> |
| Long Term Stability   | <1.0 K / yr typical                              |
| Resolution (depends on integration time) <sup>9</sup>                 | 0.1 to 1 K                                       |
| Brightness Temperature Range <sup>10</sup>                            | 0-400 K  |
| Antenna System Optical Resolution and Side Lobes                      |  |
| 22-30 GHz   | 4.9 - 6.3° -24 dB                                |
| 51-59 GHz   | 2.4 - 2.5° -27 dB                                |
| 170-184 GHz   | 1.0° - 1.1° -40 dB                               |
| Integration Time (user selectable in 10 msec increments)              | 0.01 to 2.5 seconds                              |
| Frequency Agile Tuning Range (Accuracy = $\pm 2 * 10^{-6}$ )          |  |
| Low Water Vapor Band (MP-3000A)                                       | 22.0 – 30.0 GHz (K band)                         |
| Oxygen Band (MP-3000A)  | 51.0 – 59.0 GHz (V band)                         |
| Minimum Frequency step size (K band; V band)                          | 10; 20 MHz                                       |
| Standard calibrated channels  |  |
| MP-3000A  | 35   |
| Pre-detection channel bandwidth (effective double-sided RF bandwidth) | 300 MHz  |
| Surface Sensor Accuracy   |  |
| Temperature (-50° to +50° C)  | 0.5° C @ 25° C                                   |
| Relative Humidity (0-100%)  | 2 %  |
| Barometric pressure (600 – 1100 mb)                                   | $\pm 0.5$ mb                                     |
| IRT <sup>11</sup> (Note: $\Delta T = T_{ambient} - T_{cloud}$ )       | $(0.5 + .007 * \Delta T)$ ° C                    |
| Brightness Temperature algorithm for <i>level1</i> products           | 4 point nonlinear model                          |
| Retrieval algorithms for <i>level2</i> products                       | Neural Networks                                  |

<sup>7</sup> Specified accuracy for instrument calibrated with an external target with no error.

<sup>8</sup> Absolute accuracy is best for sky brightness temperatures close to ambient, such as for the highest V band channels, and degrades as the absolute difference between the black body reference and sky temperatures increases.

<sup>9</sup> Typical resolution for 250 msec integration time is 0.25 K.

<sup>10</sup> Wider ranges are available. 0-400K is optimum for meteorological applications.

<sup>11</sup> The IRT is optional on all Profilers. The standard Field of View (FOV) = 5°. Other lenses are available.

| <b>Function or Parameter</b>   | <b>Specification</b>   |
|--|--|
| Calibration Systems<br>Primary standards<br>Operational standards  | LN2 and TIP methods<br>Noise Diodes + ambient Black Body Target  |
| Environmental Operating Range<br>Temperature <sup>12</sup><br>Relative Humidity<br>Altitude <sup>13</sup><br>Wind (operational/survival) | -40° to +45° C<br>0-100 %<br>-300 to 3000 m<br>30 m/s / 60 m/s   |
| Physical Properties<br>Size (H x W x L)<br>Mass  | 86 x 53 x 31 cm<br>27 kg (with IRT)                              |
| Power requirement (100 to 250 VAC @ 50 – 60 Hz)  | 200 watts typical (Tamb = +25C)<br>400 watts max at “cold start” |
| Data Interface<br>Primary computer port<br>Auxiliary port<br>Standard cable length <sup>14</sup>   | RS422 57600 kb/s 8N1<br>RS422 1.2 - 57600 kb/s 8N1<br>30 m       |
| Data File Formats  | ASCII CSV<br>(comma separated variables)                         |

<sup>12</sup> A high operating temperature option is available to extend operational temperature to +50C. Contact Radiometrics for details.

<sup>13</sup> The optional wide range pressure sensor (500-1060 mb) is required for operation above ~1600m.

<sup>14</sup> The 30m length is standard. RS422 communications cable lengths up to 1000 m are available by special order.

**Shipment Cases****Standard Blue Case**

2x3x27 in (109x79x69 cm)

**Weights and Dimensions**

|                                  |  |   |
|----------------------------------|--|---|
| <b><u>MP-3000A</u></b>           | 26 kg<br>27 kg<br>87x53x31 cm<br><b>76 kg</b><br><b>85 kg</b><br><br><b>109x79x69 cm</b> | Instrument weight w/o IRT<br>Instrument weight w/IRT<br>Instrument dimensions<br><b>Instrument/IRT/Ship Container</b><br><b>Instrument/Az Drive/IRT/Ship Container</b><br><b>Dimensions of shipping container</b> |
| <b><u>CALIBRATION TARGET</u></b> | 4 g<br><br>48x53x31 cm<br>14 kg<br><b>7 kg</b><br><b>66x58x41 cm</b>                     | Weight with housing<br><br>Dimensions<br>Weight with LN2<br><b>Weight in ship container w/saddle</b><br><b>Ship container dimensions</b>  |
| <b><u>TRIPOD</u></b>             | 12 kg<br>63x168 cm<br><br><b>13 kg</b><br><b>94x28x15 cm</b>                             | Instrument weight<br>Height x diameter, minimum leg extension<br><b>Packed in shipping container</b><br><b>Dimension of shipping container</b>  |
| <b><u>AZIMUTH DRIVE</u></b>      | 9 kg<br><b>30x18x15 cm</b>   | Instrument weight<br><b>Instrument dimensions (not including cable)</b>   |
| <b><u>DEWAR, 25 L</u></b>        | 15 kg<br>43x43x69 cm   | <b>Boxed weight</b><br><b>Boxed dimensions</b>  |
| <b><u>RADOME 2 or 4 PK</u></b>   | 1 kg<br>63.5x25x5 cm   | <b>Boxed weight</b><br><b>Boxed dimensions</b>  |

This page left intentionally blank.