

VAISALA

USER'S GUIDE

Vaisala Ceilometer CL31



PUBLISHED BY

Vaisala Oyj

Street address: Vanha Nurmijärventie 21, FI-01670 Vantaa, Finland

Mailing address: P.O. Box 26, FI-00421 Helsinki, Finland

Phone: +358 9 8949 1

Fax: +358 9 8949 2227

Visit our Internet pages at www.vaisala.com.

© Vaisala 2015

No part of this manual may be reproduced, published or publicly displayed in any form or by any means, electronic or mechanical (including photocopying), nor may its contents be modified, translated, adapted, sold or disclosed to a third party without prior written permission of the copyright holder. Translated manuals and translated portions of multilingual documents are based on the original English versions. In ambiguous cases, the English versions are applicable, not the translations.

The contents of this manual are subject to change without prior notice.

Local rules and regulations may vary and they shall take precedence over the information contained in this manual. Vaisala makes no representations on this manual's compliance with the local rules and regulations applicable at any given time, and hereby disclaims any and all responsibilities related thereto.

This manual does not create any legally binding obligations for Vaisala towards customers or end users. All legally binding obligations and agreements are included exclusively in the applicable supply contract or the General Conditions of Sale and General Conditions of Service of Vaisala.

Table of Contents

CHAPTER 1

GENERAL INFORMATION	7
About This Manual	7
Version Information	7
Related Manuals	7
Documentation Conventions	8
Safety	8
Terms Used in Groundings	10
Laser Safety	11
ESD Protection	13
Recycling	13
Regulatory Compliances	14
Software License	14
Warranty	15

CHAPTER 2

PRODUCT OVERVIEW	17
Introduction to Vaisala Ceilometer CL31	17
Product Nomenclature	19

CHAPTER 3

INSTALLATION	23
Preparing a Foundation	23
Creating New Concrete Foundation	25
Using an Existing Concrete Foundation	25
Grounding	25
Unloading and Unpacking	27
Mounting	28
Using Tilt Feature	30
Tilting the Ceilometer	30
Mounting the Bird Deterrent	32
Startup	33
Assembling the Battery	33
Connecting External Cables	35
Power Supply Connection	36
Data Line Connection	36
Data Line RS-485 Connection	37
Data line RS-232 Connection	38
Maintenance Terminal Connection	38
Setting up Maintenance Terminal Connection	39
Operating Maintenance Terminal Connection	39
Starting the Ceilometer	39
Settings for Normal Operation	41
Setting Up LAN Connection	42

Getting Data from CL31	43
Entering Real COM Mode	43
Entering TCP Client Mode.....	45
Entering UDP Mode.....	46
Factory Settings of User Programmable Parameters	47

CHAPTER 4

FUNCTIONAL DESCRIPTION	49
Theory of Operation	49
Basic Operating Principle	49
Practical Measurement Signal.....	49
Noise Cancellation.....	50
Return Signal Strength	51
Height Normalization	51
Backscatter Coefficient.....	52
Vertical Visibility.....	53
Sky Condition Algorithm	54
General.....	54
Option code	54
Activation	55
Algorithm Overview	55

CHAPTER 5

OPERATION.....	59
Operation Modes	59
Serial Lines - Open and Closed Port	59
User Commands	61
Data Messages.....	67
Secondary message.....	68
CL31 Data Messages No. 1 and 2	68
CRC16 Checksum.....	74
CL31 Status Message	75
CT12K Messages.....	78
CT12K Digital Message No. 2.....	78
CT12K Digital Message No. 3.....	82
CT25K Data Messages	83
CT25K Data Message No. 1	83
CT25K Data Message No. 6	85
CT25KAM Data Messages.....	86
CT25KAM Data Message No. 60.....	86
CT25KAM Data Message No. 61.....	87
LD40 Standard Telegram	87
Telegram Structure Remarks	89
Failure and Warning Messages	89
Checksum Calculation.....	92
Manual Message	93
Polling Mode	94

CHAPTER 6

MAINTENANCE.....	97
Periodic Maintenance.....	97
Alarms and Warnings	97
Cleaning	97

Window Contamination Measurement Calibration.....	98
Checking Door Gasket.....	99
Checking Battery.....	99
Storage.....	99
CHAPTER 7	
TROUBLESHOOTING	101
Troubleshooting Procedure	101
Accessing Diagnostic Information	102
Equipment for Troubleshooting.....	102
Troubleshooting Instructions.....	102
Warning and Alarm Messages	105
Technical Support.....	108
CHAPTER 8	
REPAIR	109
Replacing Window CLW311	111
Replacing Ceilometer Laser Transmitter CLT321	114
Replacing Ceilometer Receiver CLR321	117
Replacing Ceilometer Engine Board CLE321.....	119
Replacing No-break Battery	121
Replacing AC Power CLP321	123
Replacing Window Blower CLB311.....	126
Replacing Internal Heater CLH311	128
Replacing Laser Monitor Board CLM311	131
Replacing Modem Module DXL421 (Optional)	134
CHAPTER 9	
TECHNICAL DATA	135
Mechanical Specifications.....	135
External Connector J1 - Window Blower	135
External Connector J2 - Power Input.....	136
Output Interface	136
External Connector J3 - Data Line.....	136
External Connector J4 - Maintenance Line.....	138
NPort 5232-T Serial Device Server Specifications	139
Modem Module DXL421 Specifications	139
Transmitter Specifications	140
Receiver Specifications	140
Optical System Specifications	140
Performance Specifications	141
Environmental Conditions Specifications	141
APPENDIX A	
INSTALLING BIRD DETERRENT	143
APPENDIX B	
CLEANING AND MAINTAINING PAINTED SURFACES	147
Preparing for Painting	147

Painting..... 148
Commonly Used Vaisala Colors..... 148

APPENDIX C

DXL421 MODEM CONNECTION..... 149

INDEX 151

List of Figures

Figure 1	Location of Laser Aperture on CL31	12
Figure 2	Vaisala Ceilometer CL31.....	18
Figure 3	CL31 Measurement Unit Main Parts	20
Figure 4	CL31 Measurement Unit with LAN (Ethernet) Interface Option	21
Figure 5	Foundation Construction	24
Figure 6	Measurement Unit Handle.....	27
Figure 7	Removing and Attaching the Measurement Unit	28
Figure 8	Mounting the Shield.....	29
Figure 9	Tilting the Ceilometer	30
Figure 10	Ceilometer CL31 Bird Deterrent.....	32
Figure 11	Assembling the Battery	33
Figure 12	External Connectors (Bottom View).....	35
Figure 13	Data Line RS-485 Connection	37
Figure 14	Data Line RS-232 Connection	38
Figure 15	Ceilometer Engine Board CLE321	40
Figure 16	CL31 Switches	41
Figure 17	Typical Measurement Signal.....	49
Figure 18	Basic Operation of CL31 Sky Condition Algorithm in a 2D Time-Height Domain	56
Figure 19	Control Flow of Sky Condition Algorithm.....	57
Figure 20	Operation Modes.....	59
Figure 21	Open and Closed Port.....	61
Figure 22	CL31 Maintenance Parts.....	110
Figure 23	Window CLW311.....	112
Figure 24	Laser Transmitter CLT321	114
Figure 25	Routing RX and TX Flat Cables	116
Figure 26	Receiver CLR321	117
Figure 27	Ceilometer Engine Board CLE321	119
Figure 28	No-break Battery	121
Figure 29	AC Power CLP321	123
Figure 30	Window Blower CLB311-115 / CLB311-230	127
Figure 31	Internal Heater CLH311-115 / CLH311-230.....	128
Figure 32	Laser Monitor Board CLM311	131
Figure 33	DXL421 Leased Line Modem.....	134
Figure 34	Pin Connections of Connector J4.....	138
Figure 35	CL31 Bird Deterrent Installation	143
Figure 36	Bird Deterrent in Detail	144
Figure 37	Blood Knot Instructions	145
Figure 38	DXL421 Modem Connection	150

List of Tables

Table 1	Manual Revisions	7
Table 2	Related Manuals.....	7
Table 3	Specifications for the Grounding Terms	10
Table 4	Vaisala Ceilometer CL31 Main Parts	19
Table 5	Vaisala Ceilometer CL31 Optional Parts.....	19
Table 6	Factory Defaults of User-Programmable Parameters	47
Table 7	Sky Cover Values from the Sky Condition Algorithm	56
Table 8	User Level Commands	62
Table 9	Advanced Level Commands.....	65
Table 10	Messages with 10 m Resolution (Standard Mode).....	69
Table 11	Messages with 5 m Resolution (High Resolution).....	69
Table 12	Error Group Definition.....	90
Table 13	Error Group 1 (Byte 83).....	90
Table 14	Error Group 2 (Byte 84).....	90
Table 15	Error Group 3 (Byte 85).....	90
Table 16	Error Group 4 (Byte 86).....	91
Table 17	Error Group 5 (Byte 87).....	91
Table 18	Error Group 6 (Byte 88).....	91
Table 19	Error Group 7 (Byte 89).....	91
Table 20	Command Telegram Description 'Polling Request'	95
Table 21	CL31 Status, Warnings.....	105
Table 22	CL31 Status, Alarms.....	106
Table 23	CL31 Status, Miscellaneous Problems.....	107
Table 24	Available Spare Parts	109
Table 25	CL31 Mechanical Specifications.....	135
Table 26	Window Blower	135
Table 27	Power Input.....	136
Table 28	Data Line	137
Table 29	Maintenance Line	138
Table 30	NPort 5232-T Serial Device Server Specifications.....	139
Table 31	Modem Module DXL421 Specifications	139
Table 32	Transmitter Specifications	140
Table 33	Receiver Specifications	140
Table 34	Optical System Specifications	140
Table 35	Performance Specifications.....	141
Table 36	Environmental Conditions Specifications	141

CHAPTER 1

GENERAL INFORMATION

This chapter provides general notes for the manual and the product.

About This Manual

This manual provides information for installing, operating, and maintaining Vaisala Ceilometer CL31.

Version Information

Table 1 Manual Revisions

Manual Code	Description
M210482EN-G	October 2015. This manual. Updated with LAN (Ethernet) interface option.
M210482EN-F	Previous version.

Related Manuals

Table 2 Related Manuals

Manual Code	Manual Name
M210310EN	Termination Box User's Guide
M210717EN	CL-View User's Guide

Documentation Conventions

Throughout the manual, important safety considerations are highlighted as follows:



WARNING!

Warning alerts you to a serious hazard. If you do not read and follow instructions very carefully at this point, there is a risk of injury or even death.



CAUTION!

Caution warns you of a potential hazard. If you do not read and follow instructions carefully at this point, the product could be damaged or important data could be lost.



Note highlights important information on using the product.



WARNING!

Failure to comply with these precautions or with specific warnings elsewhere in this manual violates safety standards of design, manufacture, and intended use of the instrument. Vaisala assumes no liability for the customer's failure to comply with these requirements.

Safety

Vaisala Ceilometer CL31 delivered to you has been tested for safety and approved as shipped from the factory. The following safety precautions must be observed during all phases of operation, service, and repair of this instrument:



WARNING!

Ground the product, and verify outdoor installation grounding periodically to minimize shock hazard.

**CAUTION!**

Do not modify the unit. Improper modification can damage the product or lead to malfunction.

**WARNING!**

To minimize shock hazard, the instrument chassis and cabinet must be connected to an electrical ground. The instrument is equipped with a three-conductor AC power connector. The power cable must either be plugged into an approved three-contact electrical outlet or the instrument must be carefully grounded to a low-resistance safety ground.

**WARNING!**

Do not operate the instrument in the presence of flammable gases or fumes. Operation of any electrical instrument in such an environment constitutes a definite safety hazard.

**WARNING!**

Do not attempt internal service or adjustment unless another person, capable of rendering first aid and resuscitation, is present.

**WARNING!**

Because of the danger of introducing additional hazards, do not install substitute parts or perform any unauthorized modification to the instrument. Return the instrument to a Vaisala office or authorized Depot for service and repair to ensure that safety features are maintained.

**WARNING!**

Operating personnel must not remove instrument covers. Component replacement and internal adjustments must be made by qualified maintenance personnel. Do not replace components with the power cable connected. Under certain conditions, dangerous voltages may exist even with the power cable removed. To avoid injuries, always disconnect power and discharge circuits before touching them.



WARNING!

High voltage is present when the Laser Transmitter CLT321 or Receiver CLR321 covers are removed and they are connected to a powered unit. High voltage is present in AC Power Unit CLP321, Internal Heater CLH311, Ceilometer Engine Board CLE321, and the Window Blower CLB311 at the top of the Shield.

Laser Transmitter CLT321, Receiver CLR321, and AC Power Unit CLP321 are equipped with the following warning label:



Internal Heater CLH311 can be hot and is equipped with the following warning labels:

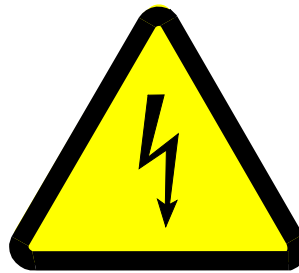

Terms Used in Groundings

Table 3 Specifications for the Grounding Terms

Term	Description
GND	Electronics common return, used only for signal and data circuits
SGND	Shield Ground for signal cables shields
PE	Protective Earth, connects touchable metal structures to safe potential. Recognized by Earth symbol (on the left) and green or yellow-green wire insulation.
	

Laser Safety

Vaisala Ceilometer CL31 is classified as a Class 1M laser device in accordance with International Standard IEC/EN 60 825-1. Complies with 21 CFR 1040.10 and 1040.11 except for the deviations pursuant to the Laser Notice No. 50, dated July 26, 2001. This means that when CL31 is installed in a field environment with instrument covers on and pointed vertically or near-vertically, it poses no established biological hazard to humans.

The device is equipped with the following label:



CL31 is intended for operation in an area restricted from public access, and to be pointed vertically or near-vertically.

Invisible laser radiation is emitted through the aperture on top of the ceilometer. The location of the laser aperture is shown Figure 1 on page 12.

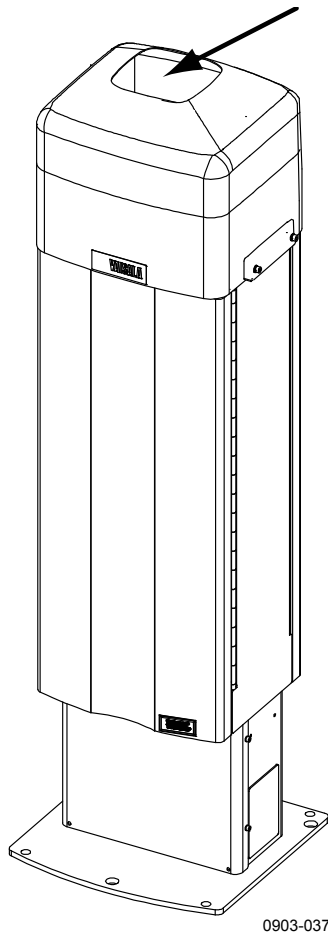

Figure 1 Location of Laser Aperture on CL31

Take the following precautions during the service and maintenance of the unit:



WARNING!

Never look directly into the Ceilometer Transmitter or Ceilometer Optics with magnifying optics (such as glasses, binoculars, and telescopes). Never remove the Ceilometer Transmitter from its normal position without first switching off both the line and the battery power and detaching the transmitter ribbon cable from the Ceilometer Engine Board.

When operating, avoid looking at the ceilometer unit from the beam direction. When tilting the unit, make sure that it is not being viewed from the beam direction with magnifying optics.

Only trained personnel should perform maintenance functions. Access to the work area by unauthorized persons during service operations must be prevented.

ESD Protection



CAUTION!

The equipment contains parts and assemblies sensitive to damage by Electrostatic Discharge (ESD). Use ESD precautionary procedures when touching, removing or inserting any objects inside the equipment housing.

Electrostatic Discharge (ESD) can cause immediate or latent damage to electronic circuits. Vaisala products are adequately protected against ESD for their intended use. However, it is possible to damage the product by delivering electrostatic discharges when touching, removing, or inserting any objects inside the equipment housing.

To make sure you are not delivering high static voltages yourself:

- Handle ESD sensitive components on a properly grounded and protected ESD workbench. When this is not possible, ground yourself to the equipment chassis before touching the boards. Ground yourself with a wrist strap and a resistive connection cord. When neither of the above is possible, touch a conductive part of the equipment chassis with your other hand before touching the boards.
- Always hold the boards by the edges and avoid touching the component contacts.

Recycling



Recycle all applicable material.



Dispose of batteries and the unit according to statutory regulations. Do not dispose of with regular household refuse.

Regulatory Compliances

Vaisala Ceilometer CL31 complies with the Low Voltage Directive (2006/95/EC) and the EMC-Directive (2004/108/EC). The conformity is shown by compliance with the following standards:

- EN 60950-1:2006 Information technology equipment - Safety - Part 1: General requirements
- EN 61326-1:2006-04 Electrical equipment for measurement, control and laboratory use - EMC requirements - Basic immunity test requirements.
- EN 55022:2006 + Am 1:2007 to EN55022:2006 Class B. Information technology equipment - Radio disturbance characteristics - Limits and methods of measurement.
- EN 61000-3-2 (2006) Limits for harmonic current emissions
- EN 61000-3-3 (2008) Limitation of voltage changes, voltage fluctuations and flicker in public low-voltage supply systems.



Software License

This product contains software developed by Vaisala. Use of the software is governed by license terms and conditions included in the applicable supply contract or, in the absence of separate license terms and conditions, by the General License Conditions of Vaisala Group.

This product may contain open source software (OSS) components. In the event this product contains OSS components, then such OSS is governed by the terms and conditions of the applicable OSS licenses, and you are bound by the terms and conditions of such licenses in connection with your use and distribution of the OSS in this product. Applicable OSS licenses are included in the product itself or provided to you on any other applicable media, depending on each individual product and the product items delivered to you.

Warranty

Visit our Internet pages for standard warranty terms and conditions:
www.vaisala.com/warranty.

Please observe that any such warranty may not be valid in case of damage due to normal wear and tear, exceptional operating conditions, negligent handling or installation, or unauthorized modifications. Please see the applicable supply contract or Conditions of Sale for details of the warranty for each product.

This page intentionally left blank.

CHAPTER 2

PRODUCT OVERVIEW

This chapter introduces product features and nomenclature.

Introduction to Vaisala Ceilometer CL31

Vaisala Ceilometer CL31 measures cloud height and vertical visibility.

CL31 employs pulsed diode laser LIDAR technology (LIDAR = Light Detection and Ranging), where short, powerful laser pulses are sent out in a vertical or near-vertical direction. The reflection of light, backscatter – caused by haze, fog, mist, virga, precipitation, and clouds – is measured as the laser pulses traverse the sky. The resulting backscatter profile, that is, the signal strength versus the height, is stored and processed, and the cloud bases are detected. The time delay between the launch of the laser pulse and the detection of the backscatter signal indicates the cloud base height.

CL31 is able to detect three cloud layers simultaneously. If the cloud base is obscured due to precipitation or ground-based fog, CL31 reports Vertical Visibility. There is no need for adjustments in the field. The embedded software includes several service and maintenance functions and gives continuous status information from internal monitoring. The software is designed to give the full backscatter profile.

CL31 includes data messages used in CT12K, CT25K, CT25KAM, and LD40. Therefore it is easy to transfer from older ceilometer versions to CL31.

You can order CL31 with an optional Air Quality Plug-and-Play package. With the package, you can connect to up to four destination IP addresses. The package contains:

- Two Ethernet cables
- An Ethernet switch
- Ethernet switch AC power cables with plugs for the USA, the EU, and the UK
- Ceilometer AC power cables with plugs for the USA, the EU, and the UK
- Laptop with BL-View and CL-View software installed

Note that the LAN module rules out the radio kit and Humitter options.

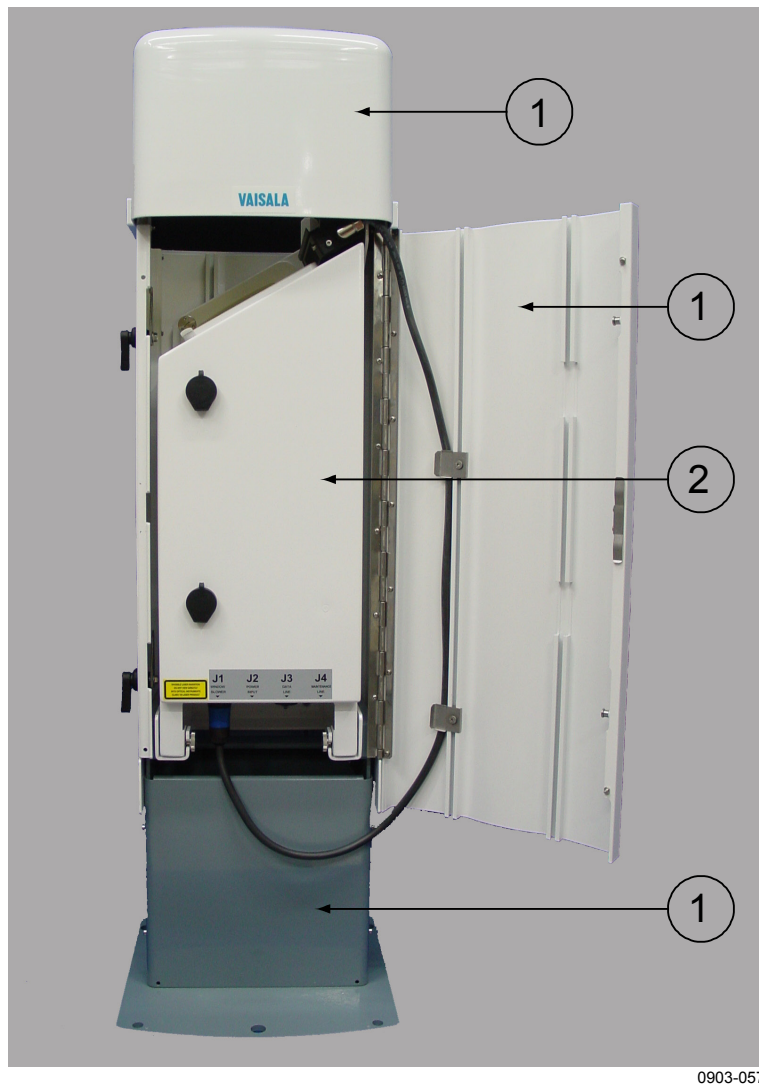

Figure 2 Vaisala Ceilometer CL31

- 1 = Shield
- 2 = Measurement Unit

Product Nomenclature

Table 4 Vaisala Ceilometer CL31 Main Parts

Code	Common Name
CLO321	Optics Unit
CLW311	Window
CLT321	Transmitter
CLR321	Receiver
CLM311	Laser Monitor Board
CLE321	Engine Board
CLP321	AC Power Unit
226116	No-break Battery
CLH311-115	Inside Heater (100 ... 115 VAC)
CLH311-230	Inside Heater (220 ... 240 VAC)
CLB311-115	Window Blower (100 ... 115 VAC)
CLB311-230	Window Blower (220 ... 240 VAC)
CT3839	Power cable (230 V)
CT35324	Power cable (115 V)
CT3838	Data cable
226296	Coaxial Cable

Table 5 Vaisala Ceilometer CL31 Optional Parts

Code	Common Name	Description
CL31BIRDKIT	Bird Deterrent	
DXL421	Modem Module	
CLRADIOKIT	Radio Modem Installation Kit	Excl. radio modem and antenna
TERMBOX-1200	Termination box, Mains and signal	For extended surge and overvoltage protection
CLTERMBOX	Termination boxes for Mains and Signal	Without surge and overvoltage protection
QMZ101	Maintenance cable	
CLTERMHOOD	Optical Termination Hood	
CT35022	Shock Absorber	For ship installations
CLHUMITTER	Internal Humidity Transmitter	
CL31USBCABLE	USB maintenance cable	
CLAQPACKAGE	Air Quality Plug-and-Play package	Laptop, Ethernet switch, two Ethernet cables, Ethernet switch power source, three ceilometer AC power cables, BL-View and CL-View software

The complete delivery also includes mating cables with connectors for power and communication, installation hardware, a key for the measurement unit door, and this CL31 User's Guide.

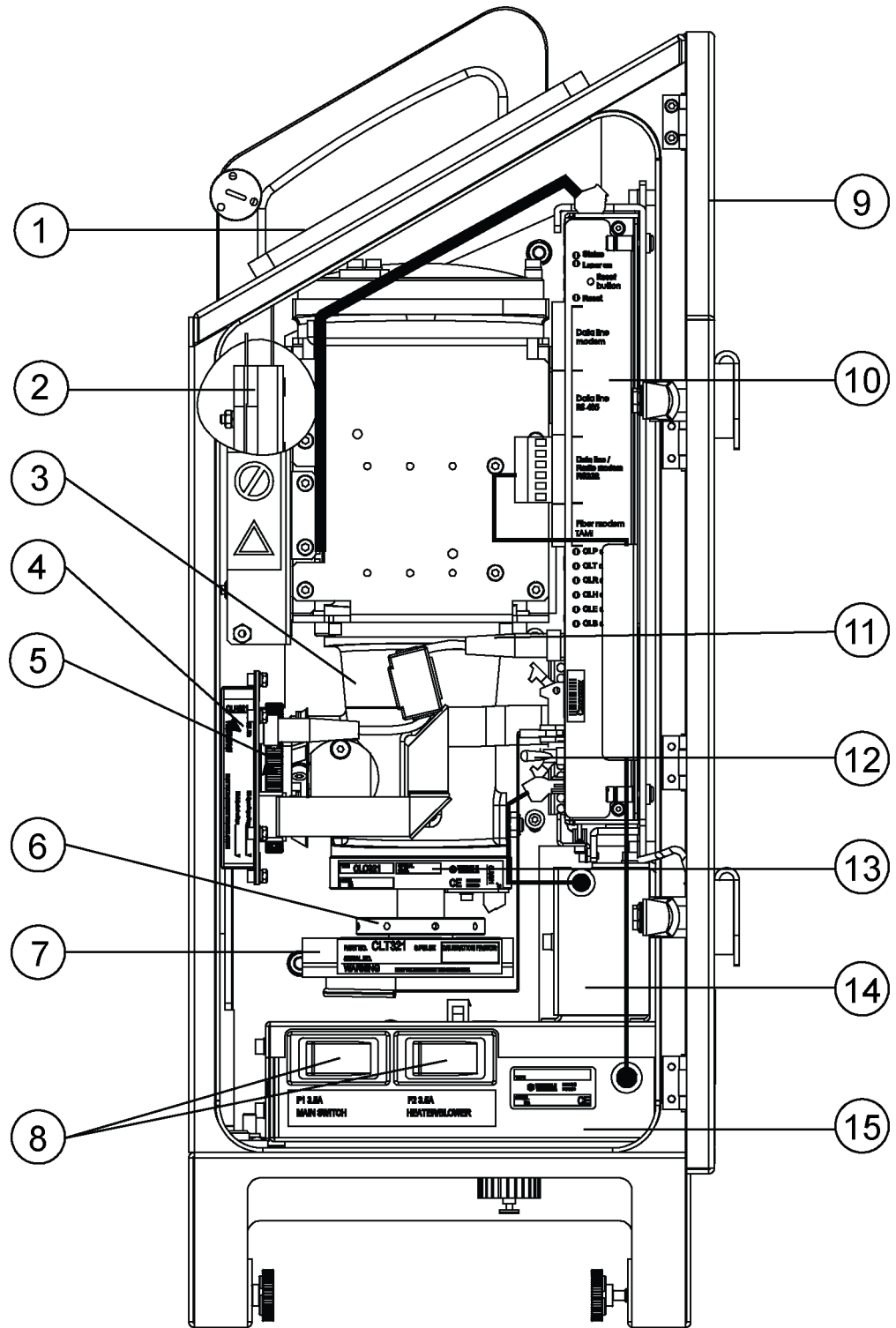

0910-119

Figure 3 CL31 Measurement Unit Main Parts

- 1 = Window CLW311
- 2 = Internal heater CLH311
- 3 = CLO321 Optics unit
- 4 = Ceilometer Receiver CLR321
- 5 = Receiver ring
- 6 = Transmitter ring
- 7 = Ceilometer Transmitter CLT321
- 8 = Main circuit breakers, F1
- 9 = Measurement Unit Enclosure
- 10 = Ceilometer Engine Board CLE321
- 11 = Coaxial cable 226296
- 12 = Battery Switch
- 13 = Laser Monitor Board CLM311
- 14 = Battery Cage
- 15 = AC Power CLP321

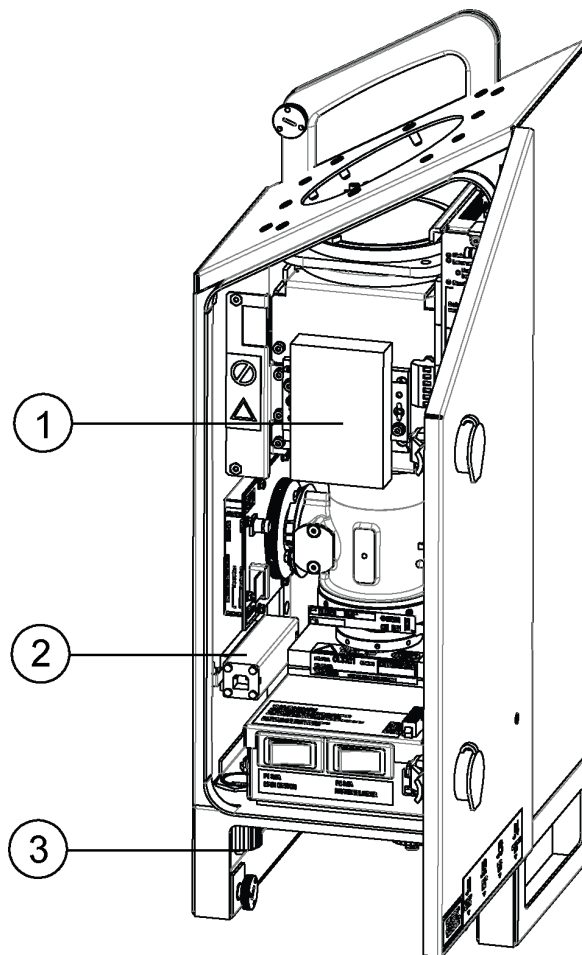

Figure 4 CL31 Measurement Unit with LAN (Ethernet) Interface Option

- 1 = MOXA NPort 5232-T modem
- 2 = Ethernet Surge Protector
- 3 = RJ45 Connector

This page intentionally left blank.

CHAPTER 3

INSTALLATION

This chapter provides information on installing the product.

Preparing a Foundation

When choosing an installation site Vaisala recommends that you use a wide open place where there are no tall trees, overhead lines, or antennas that could bend or move to the ceilometer measurement path. If CL31 is installed in the proximity of radars or other powerful radio transmitters, Vaisala recommends positioning the measurement unit door away from such sources.

The standard foundation for the CL31 ground installation is a concrete foundation. For the recommended minimum dimensions, see Figure 5 on page 24. Mounting screws and bolts are included in the delivery.



In case CL31 replaces another ceilometer (CT25K, CT12K, LD40, LD25, or LD12) the existing foundation and foundation screws can be used.

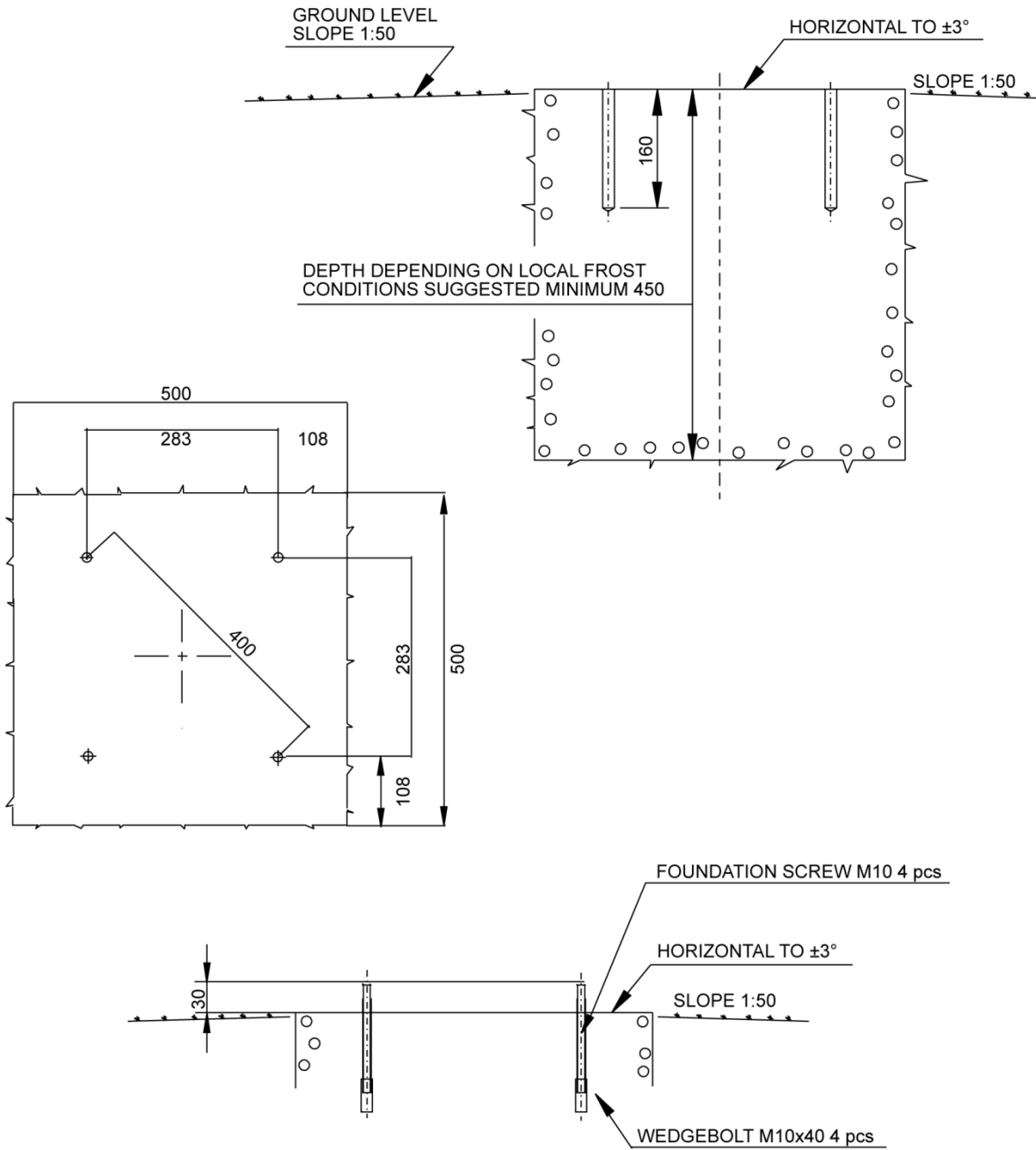

0911-074

Figure 5 Foundation Construction

There are two ways to create a concrete foundation for CL31: You can either use an existing concrete foundation or create a new one.



If you plan to use the tilt feature, consider this in the layout of the foundation screws and shield placement. For more information, see Using Tilt Feature on page 30.

Creating New Concrete Foundation

To create a concrete foundation:

1. Fasten the M10 × 40 wedge bolts to the lower ends of the foundation screws (four each).
2. Fix a drilling template to the upper ends of the foundation screws with nuts.
3. Place the template with the attached foundation screws into the hole in such a way that approximately 30 mm (1.25 inches) of the foundation screw threads stand above the surface. Note the cardinal points indicated in Figure 5 on page 24.
4. Pour in the concrete and finish the foundation.

Using an Existing Concrete Foundation

To use an existing concrete foundation:

1. Drill four holes with a diameter of 12 mm and a depth of 165 mm (0.5 × 6.5 inches) into the concrete. Note the cardinal points indicated in Figure 5 on page 24.
2. Fasten the M10 × 40 wedge bolts to the lower ends of the foundation screws (four each).
3. Place the wedge bolt and foundation screw combinations into the holes, with the wedge bolts down, and hammer the protruding threads down.
4. Tighten the foundation screws a few turns to attach the wedge bolts to the hole walls.

Grounding

CL31 is equipped with a separate grounding screw for external grounding at the bottom of the shield.



CAUTION!

At the installation site, a connection to a solid earth ground is mandatory for adequate lightning and transient protection.

To connect the grounding nut to the grounding rail:

1. The grounding nut is in the bottom of the Measurement Unit. Connect the grounding nut to the grounding rail in the bottom of the shield.

CL31 is designed as protection class I (safety grounded) electrical equipment. For safe use, you must connect the CL31 AC power supply cable to a grounded AC power socket.

The communication line signal ground is also internally connected to the device chassis/safety ground.

If the application requires a “floating” galvanic installation, such as in marine applications with only IT-power supply available, and high voltage insulation from AC power and/or signal lines to the chassis, do the following:

1. Use a 500 VA isolation transformer in the AC power input and bond the chassis ground to the installation platform (the metal hull/deck).
2. Connect the communication line to the data receiving system through a galvanic signal isolator or use fiber-optic communication.

Unloading and Unpacking

CL31 is shipped in a package that contains the shield, the measurement unit inside the shield, all the equipment, accessories, and documentation. Store the original packaging for a possible later transportation need.



The unit is heavy. Vaisala recommends that unloading and unpacking is carried out by two people.

When opening, place the package on a flat surface with the indicated top side up. Open the container from the top side and carefully remove the ceilometer and other equipment.

- Use gloves for protection against sharp edges.
- Avoid touching the window or lens surfaces. Do not remove the protective sheet from the measurement unit window.
- Do not remove the integral protective caps from the unused external connectors (J4 Maintenance line).
- Use the measurement unit handle for lifting and carrying the measurement unit.

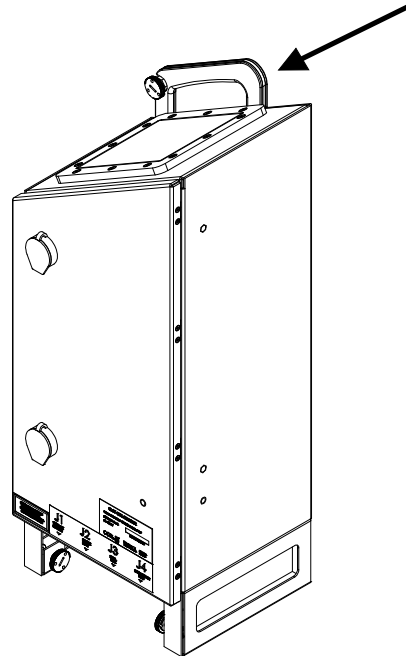

0910-118

Figure 6 Measurement Unit Handle

If mishandling occurs during transportation or installation, return the instrument to a Vaisala office or authorized Depot for inspection.

Mounting

CL31 is delivered with the measurement unit attached to the shield. Vaisala recommends that you first remove the measurement unit, mount the shield onto the foundation, and then install the measurement unit onto the shield.

To mount CL31:

1. Remove the measurement unit from the shield. Loosen the three attachment screws (A in Figure 7), disconnect the blower cable from connector J1, and pull out the unit.

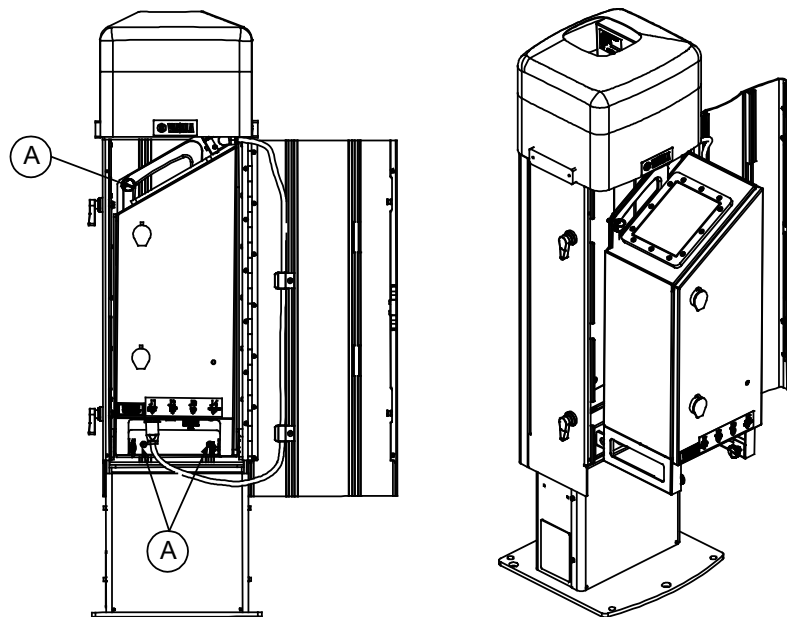

0902-010

Figure 7 Removing and Attaching the Measurement Unit

2. Place the shield on the foundation so that the door faces North in the Northern hemisphere and South in the Southern hemisphere. See Figure 8 on page 29.
3. Place the washers on the foundation screws and tighten the nuts. See Figure 8.



For installing an optional bird deterrent, see section Mounting the Bird Deterrent on page 32.

4. Place the measurement unit inside the shield, tighten the three attachment screws (A in Figure 7) and connect the blower cable to connector J1.

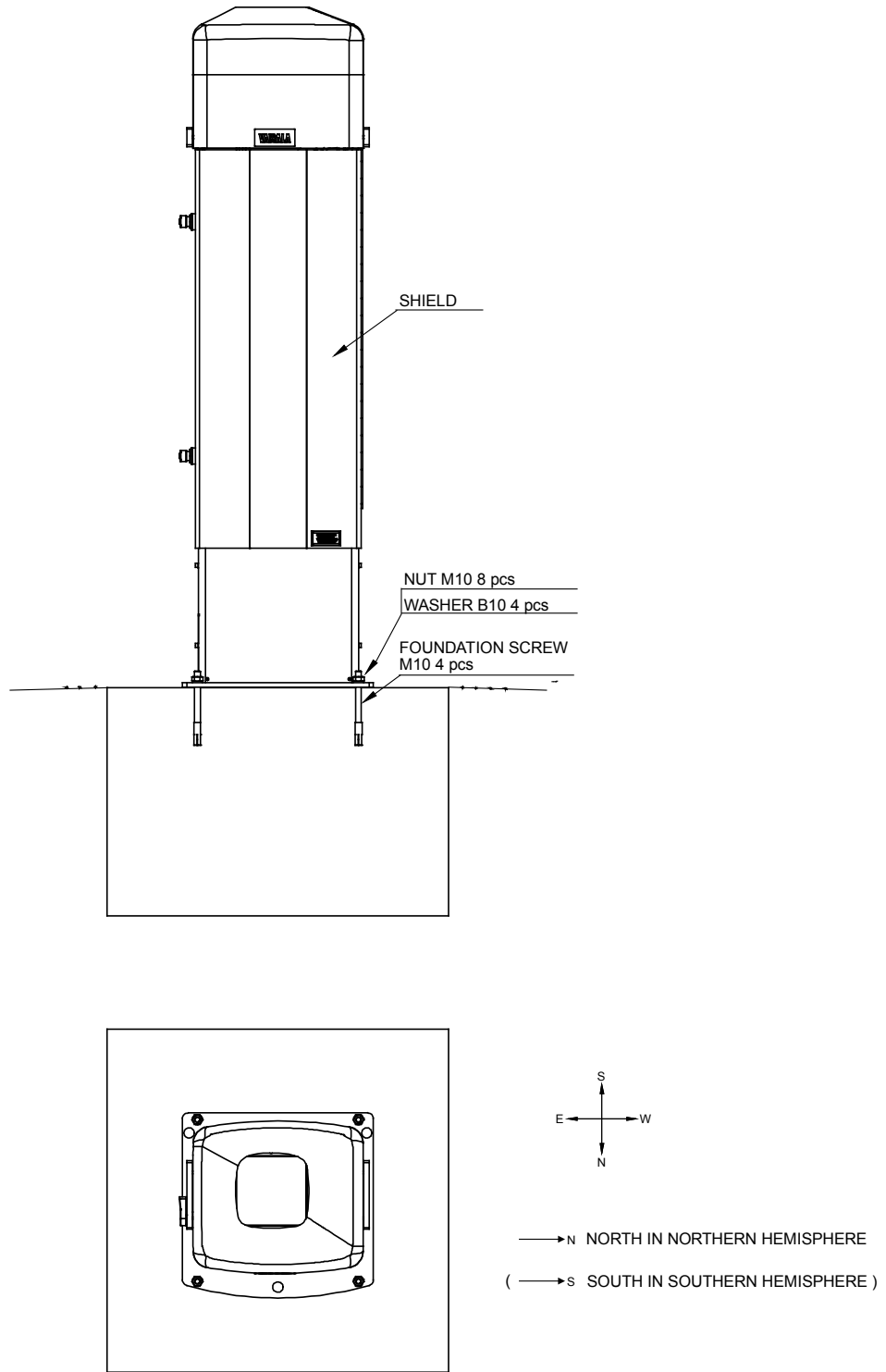

0910-120

Figure 8 Mounting the Shield

Using Tilt Feature

CL31 can operate in a tilted position. The built-in sensor detects the tilt angle, that is, the deviation from vertical. The tilt feature allows three tilt angles: vertical, 12 degrees with the measurement unit door upwards, and 12 degrees with the measurement unit door downwards. The tilt angle is used for an automatic correction of the detected cloud base height, enabling accurate measurements in a tilted position.

The tilt feature provides the following advantages:

- Protection in heavy weather conditions:
In heavy weather conditions, using a tilt angle of 12 degrees protects the measurement unit window from precipitation, thus enhancing performance.
- Precision in aircraft approach control:
The beam can be pointed towards the approach direction of an aircraft. This is useful, for example, for helicopter approaches, and at sites where the ceilometer cannot be located exactly at the desired spot.

Tilting the Ceilometer

Remove the measurement enclosure. See Figure 7 on page 28. You need a 5 mm Allen-key for tilting.

To tilt CL31:

1. Loosen the tilting screws on both sides.

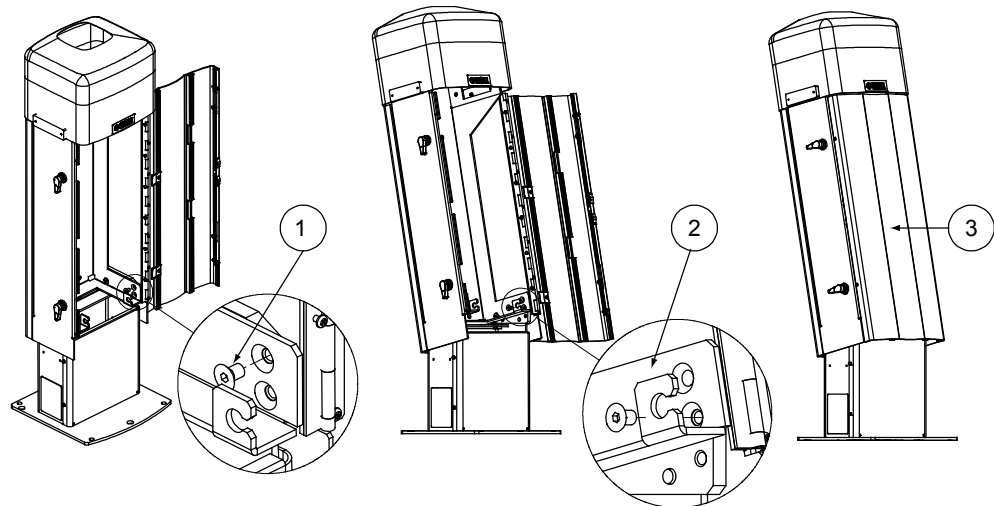

Figure 9 Tilting the Ceilometer

2. Tilt the ceilometer shield 12 degrees. Vaisala recommends tilting the ceilometer forwards, with the measurement unit door facing down. Lock it in place with the screws.

**WARNING!**

When the unit is operating in a tilted position, make sure that it is not being viewed from the beam direction with magnifying optics.



To avoid direct sunlight, tilt the unit away from the sun. That is, tilt it north in the northern hemisphere and south in the southern hemisphere. Direct solar radiation exposure does not damage the unit but may cause alarms and temporarily invalidate the data.

As the benefits of different tilting directions may be contradictory or cannot be realized simultaneously, the user must decide the direction of the final installation.

Mounting the Bird Deterrent

You can order CL31 with an optional bird deterrent. It prevents birds from landing on the ceilometer which could interfere with the measurements.

The bird deterrent kit consists of two side plates, a piece of fluorocarbon line and two optional perches. To mount the bird deterrent, you need an 8 mm wrench and a 4 mm Allen-key.

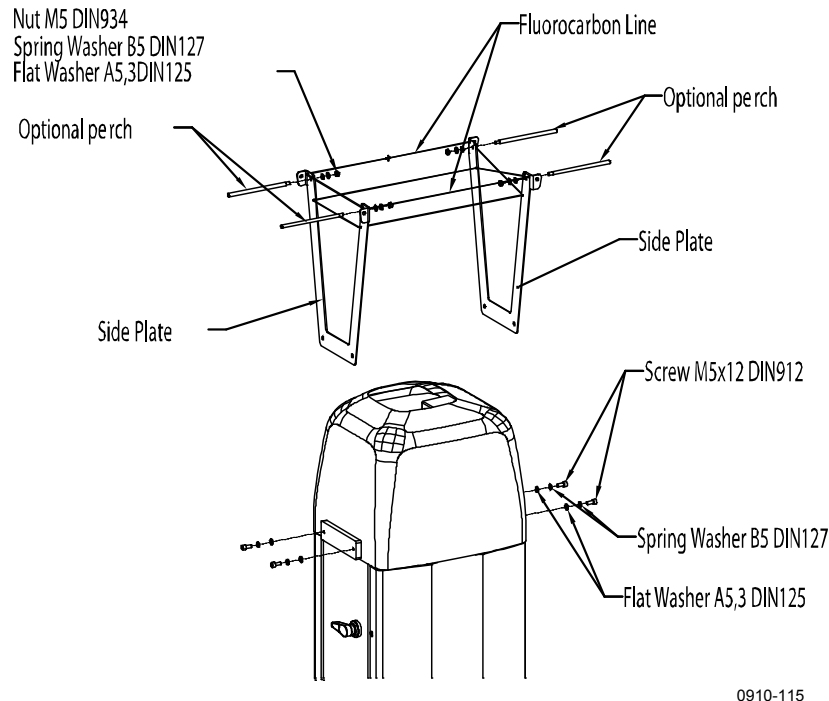

0910-115

Figure 10 Ceilometer CL31 Bird Deterrent

To mount the bird deterrent:

1. Place the side plates on both sides of the ceilometer top cover and attach them with two washers and screws.
2. Slide a fluorocarbon line back and forth through the designated holes on the side plates, starting from the front of the ceilometer and continuing until the ends of the line meet on the back side of the ceilometer. See Figure 10.
3. Tie the line ends together with a blood knot so that the line is left slightly loose.
4. Attach the optional bird perches to the side plates.

For detailed drawings of the bird deterrent installation and the blood knot, see Appendix A, Installing Bird Deterrent, on page 143.

Startup

This section describes the aspects of CL31 that you need to consider before starting up the device.

Assembling the Battery

The no-break battery is delivered with CL31, but it does not come attached to the measurement unit.

To attach the no-break battery, you need a crosshead screwdriver and a 3 mm Allen-key.

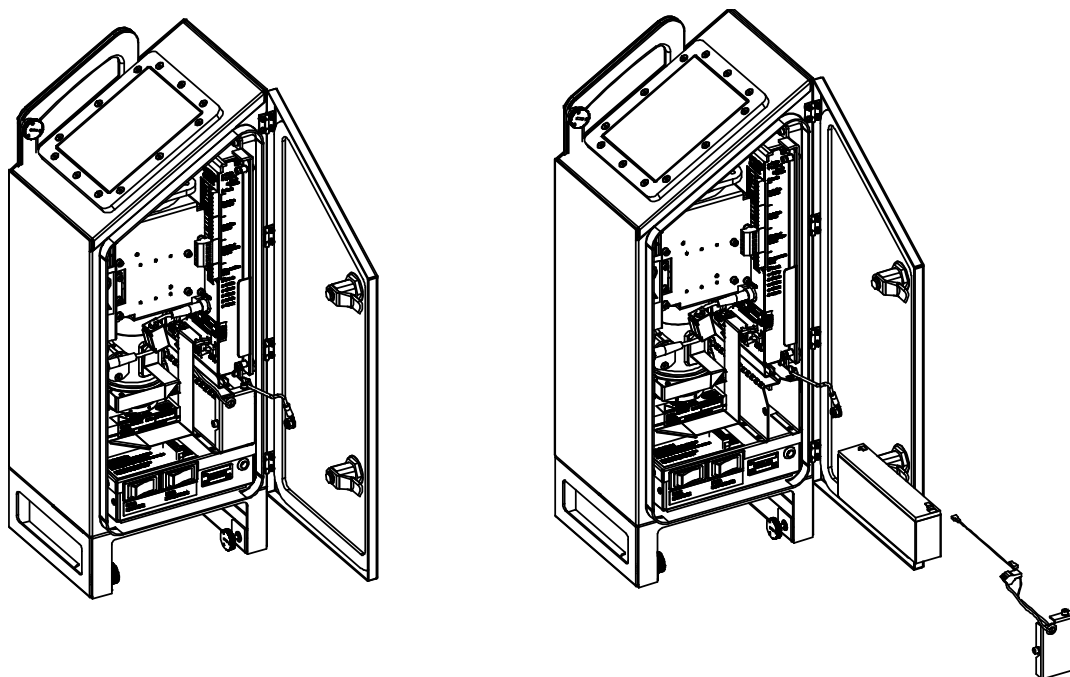

0910-126

Figure 11 Assembling the Battery



CAUTION!

Be careful not to short-circuit the battery.

To assemble the battery:

1. Open the measurement unit door and loosen the two screws locking the lid of the no-break battery cage. Do not remove the screws entirely. See Figure 3 on page 20.
2. Connect the battery cable to the new battery, connecting the red end to the positive (+) end terminal and the black end to the negative (-) end terminal.
3. Open the battery cage lid and slide the battery into the battery cage.
4. Close the battery cage lid and tighten the two screws to their places.
5. Connect the no-break battery cable to the CLE321 board.

Connecting External Cables

All external connectors are located at the bottom of the measurement unit. Figure 12 shows the external connectors J1, J2, J3, and J4.

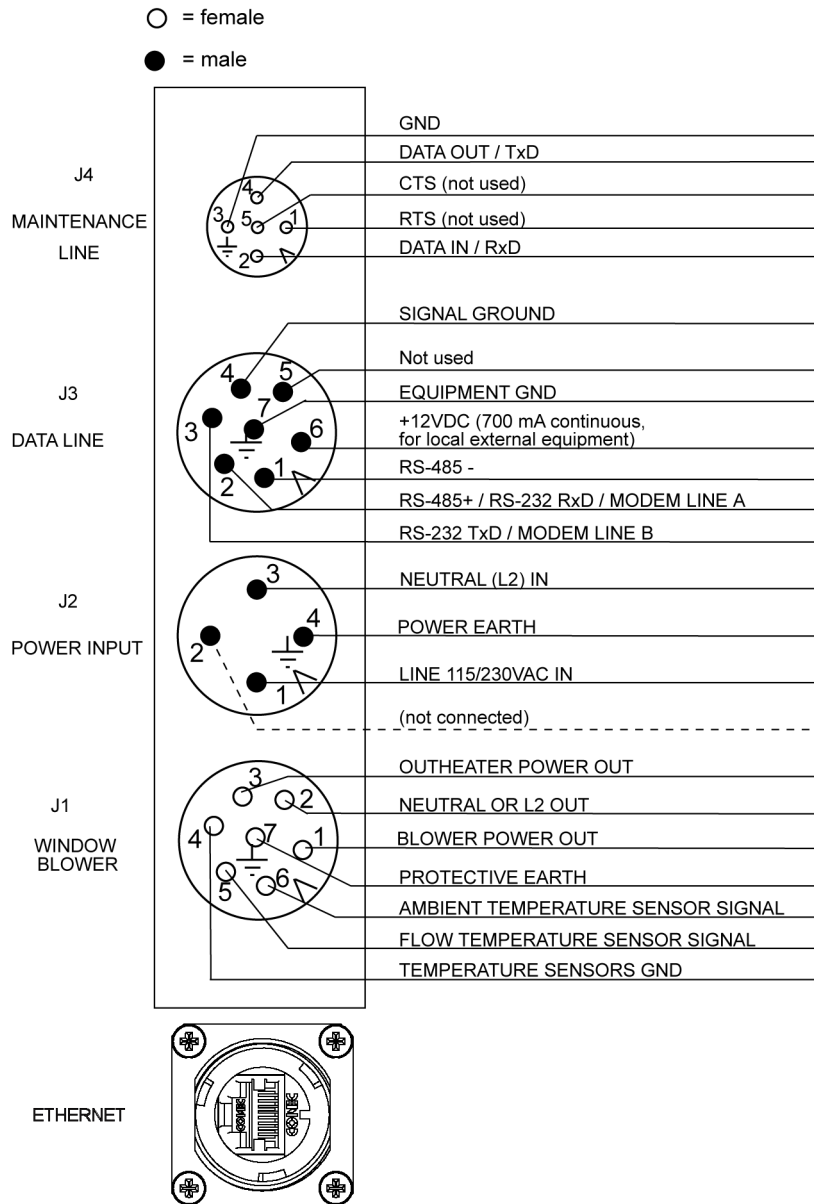

1505-053

Figure 12 External Connectors (Bottom View)

The window blower mounted into the shield is connected to J1. Line power is connected to J2. In normal use, remote communication is connected to J3. A local maintenance terminal, such as a laptop, can be connected to J4. A protective cap is included for covering J4 when it is not in use.

The power supply connector J2 provides a standard protective ground for the instrument chassis.

Power Supply Connection

1. Turn the main circuit breaker F1 to the Off position (for location, see Figure 16 on page 41).
2. Plug in the line supply cable to connector J2 (for location, see Figure 12 on page 35) after checking the voltage of the power supply cable connector.

External mating connectors with 2 m (7 ft) cable are included for J2 and for J3. The power plug of the J2 cable can be cut when the unit is permanently installed at the final site.

For the wire connections and cable glands of the optional Termination Box, see Termination Box TERMBOX-9000, 1200, 1212 User's Guide (M210310EN).



Power supply has to be protected with fuse. Maximum size of the fuse protecting the power line is 10 A for 230 V supply or 15 A for 100 V / 115 V supply.

Data Line Connection

CL31 offers three data line options:

- RS-485 connection
- RS-232 connection
- LAN (Ethernet) connection (optional)

To change the connection type, see the commands in Table 8 on page 62. For information on modem line, see Appendix C, DXL421 Modem Connection, on page 149.

Data Line RS-485 Connection

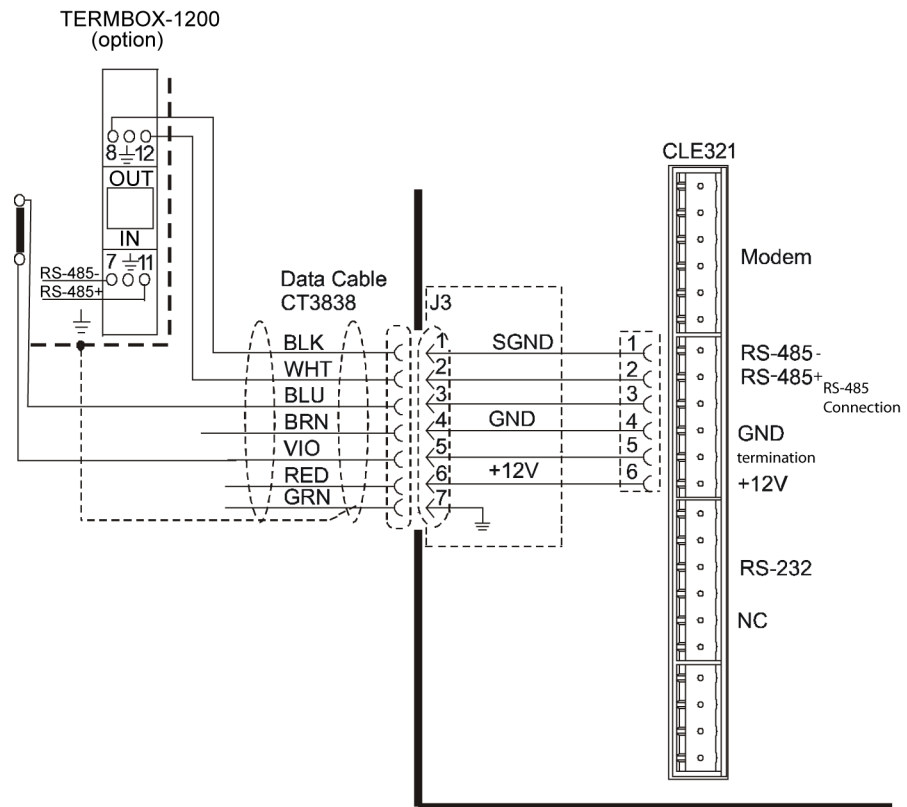

1206-012

Figure 13 Data Line RS-485 Connection

The RS-485 connection is provided with a termination. If the ceilometer is connected to the end of a long line, it may be advantageous to connect the two signals marked "termination" as shown; this can improve data transmission speed, quality, and reliability.

Default Settings for the Data Line RS-485 Connection

Bit rate	19200
Data bits	8
Stop bits	1
Parity	None

Data line RS-232 Connection

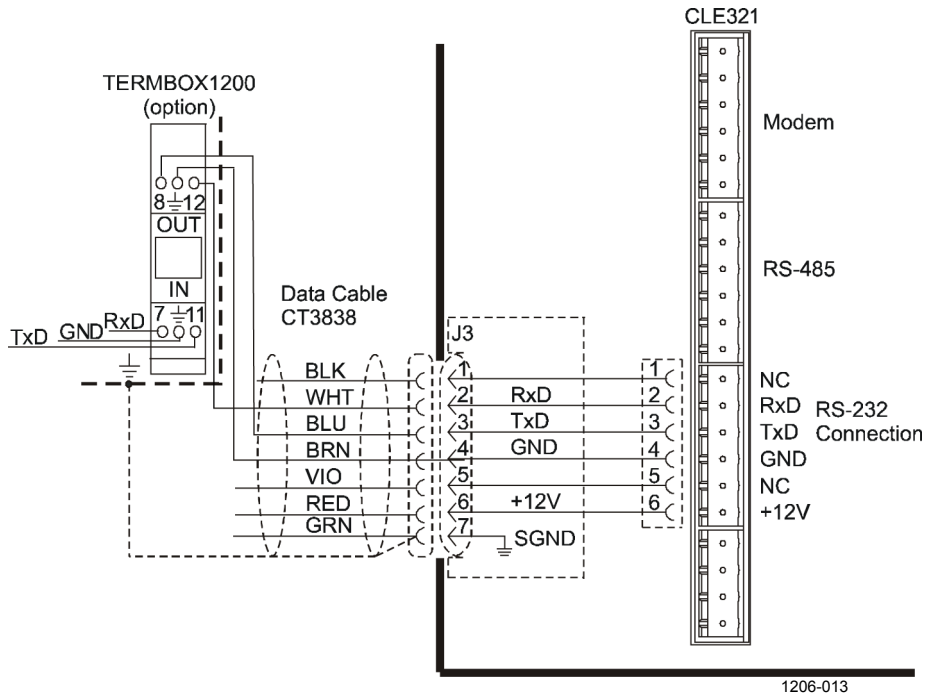

Figure 14 Data Line RS-232 Connection

Default Settings for the Data Line RS-232 Connection

Bit rate	19200
Data bits	8
Stop bits	1
Parity	None
Handshake	None

Maintenance Terminal Connection

Any terminal or PC with a serial interface and a terminal emulation program can be used for operating CL31. The maintenance terminal connection is established with the QMZ101 maintenance cable, which connects the RS-232 port of the PC to the maintenance port of the ceilometer.

Setting up Maintenance Terminal Connection

To set up the connection:

1. Connect the RS cable to the ceilometer maintenance port (connector J4) and the terminal computer.
2. Configure the terminal as follows:

Bit rate	9600
Data bits	8
Stop bits	1
Parity	None
Handshake	None

Operating Maintenance Terminal Connection

To operate the connection:

1. Turn the power on in CL31.
2. Open the CL31 maintenance with the **open** command.
3. The prompt `CEILO >` appears. For details, see Operation, on page 59.

Starting the Ceilometer

To start CL31:

1. Open the unit door and make a visual check of the internal connectors and subassemblies (see Figure 22 on page 110).
2. Turn the Main Circuit Breaker F1, the Window Blower Circuit Breaker F2, and the Battery Switch to the **On** position.

After initialization, the **Laser on** LED starts blinking at 2-second intervals. Also the six diagnostic LEDs light up. For location of the LEDs and switches, see Figure 15 on page 40 and Figure 16 on page 41.



WARNING!

Make sure that nobody is viewing the unit from the beam direction with magnifying optics.

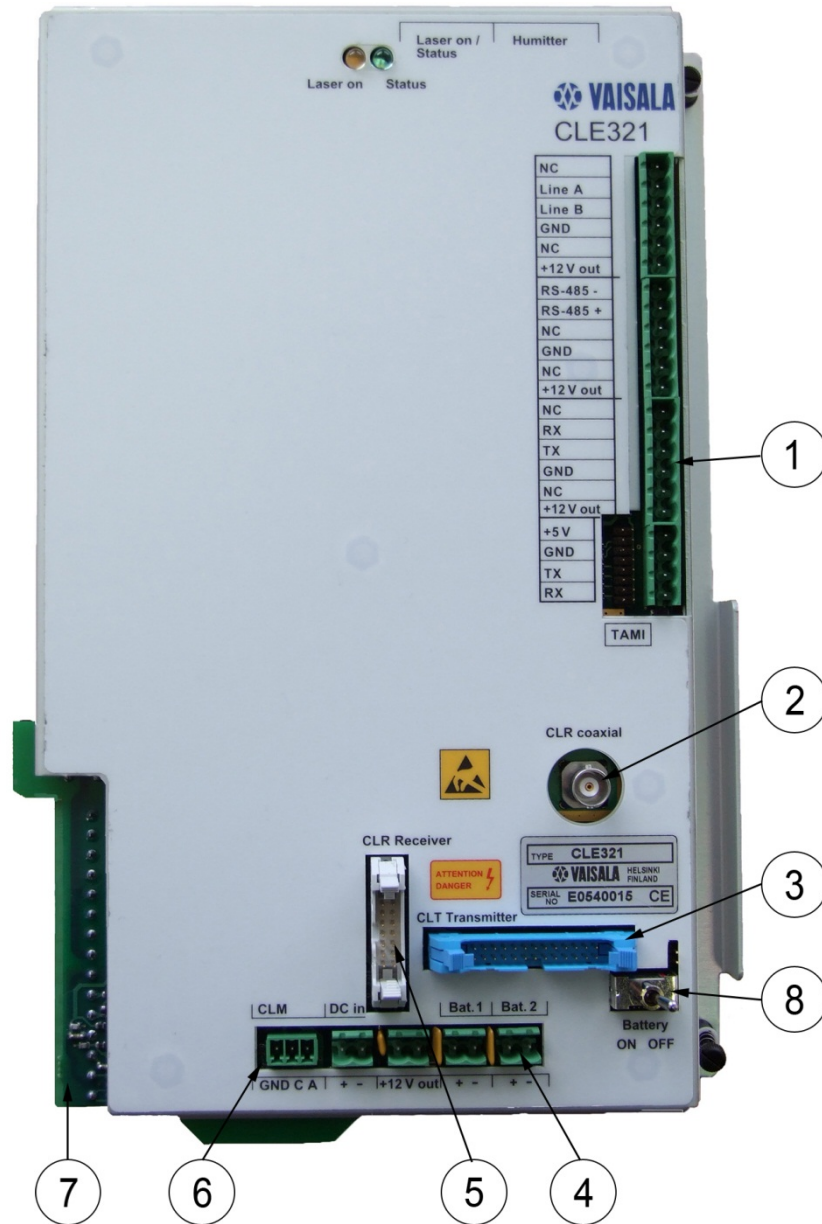

0910-103

Figure 15 Ceilometer Engine Board CLE321

- 1 = Data line connection to AC Power CLP321
- 2 = Coaxial cable connection to Ceilometer Receiver CLR321
- 3 = Connection to Ceilometer Transmitter CLT321
- 4 = Connection to Battery
- 5 = Connection to Ceilometer Receiver CLR321
- 6 = Connection to Laser Monitor Board CLM311
- 7 = Connection to AC Power CLP321
- 8 = Battery Switch

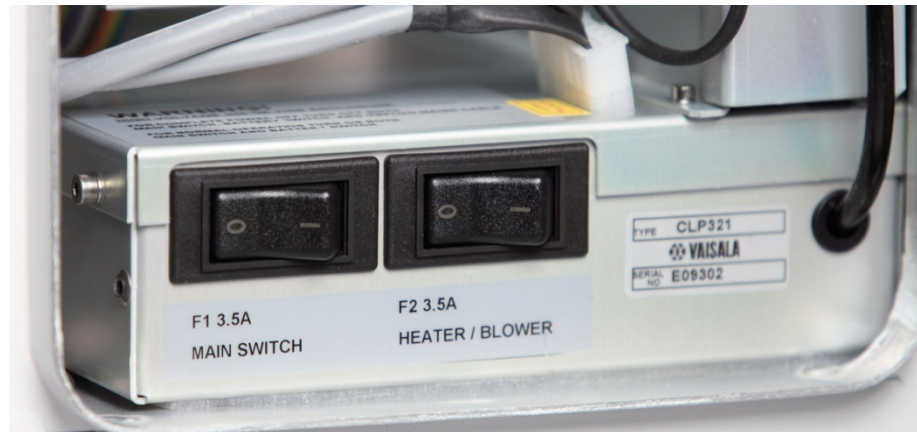

1412-160

Figure 16 CL31 Switches

Settings for Normal Operation

The switch settings for normal operation are as follows:

Main circuit breaker F1	ON
Heater/Blower circuit breaker F2	ON
Battery switch	ON

The data message and interface configuration, as well as the configuration of measuring interval and transmission speed, are standard factory settings. The settings can be changed by giving commands from the terminal.

During the factory alignment procedure, the optical adjustments are carefully carried out to fulfill the requirements and specifications of the device. Optical adjustments have been made at the factory or depot, and there is no need to readjust them in the field.



To switch the CL31 fully off, turn off the battery switch and the line power switch. Having the unit on with the battery supply will drain the battery.

Setting Up LAN Connection

If you have the LAN output option or the Air Quality Plug-and-Play package, connect the laptop and CL31 to the Ethernet switch with Ethernet cables.

To open LAN connection:

1. Connect the Ethernet Cable to the laptop and to CL31 as shown in Figure 12 on page 35.
2. With the laptop Internet browser, go to <http://192.168.127.254/>. NPort Web console opens.

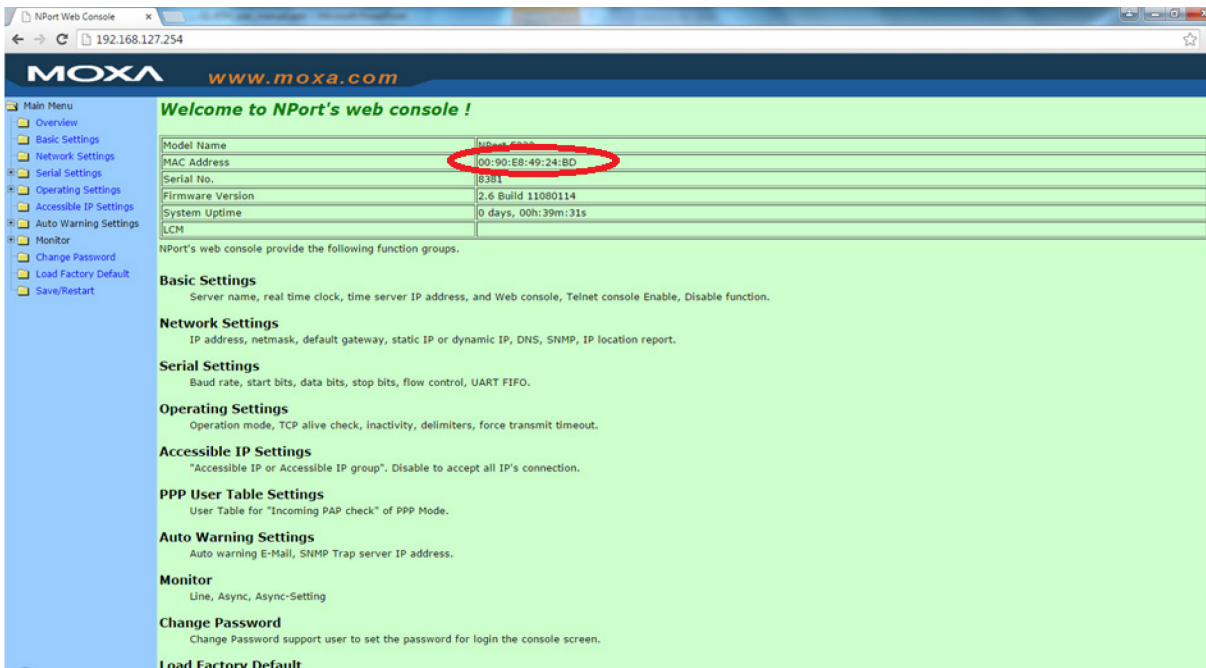

4. To change network settings, select **Network Settings**. If you use DHCP IP configuration, add the CL31 MAC address to the allowed addresses on your DHCP server.
5. Click **Submit**.

Getting Data from CL31

There are three modes for getting data from CL31:

- Real COM mode
- TCP Client mode
- UDP mode

Entering Real COM Mode

To enter Real COM mode:

1. Install and open NPort Windows Driver Manager:
 - a) Download the NPort Windows Driver Manager file from http://www.moxa.com/support/download.aspx?d_id=1359
 - b) Open the file and run installation.
2. Select **Add**.

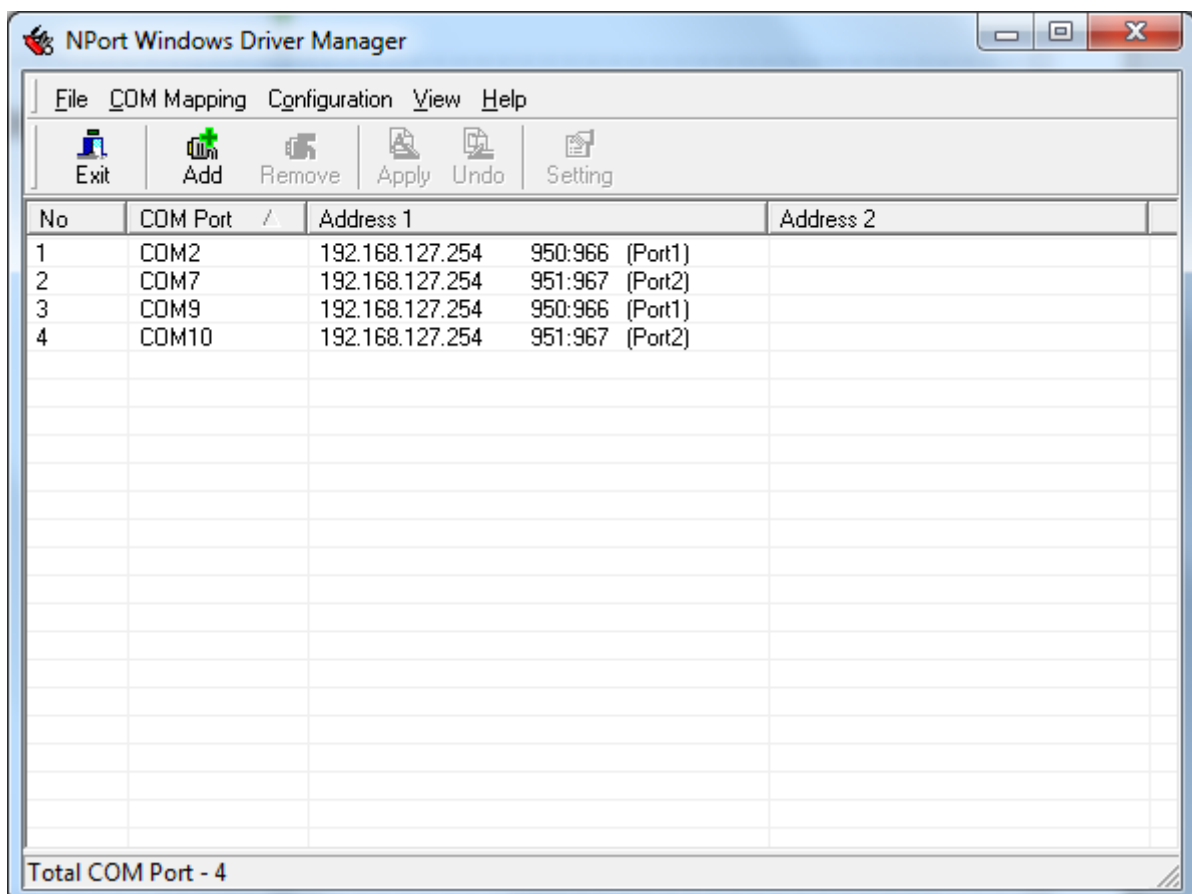

3. Select the correct NPort and click **OK**.

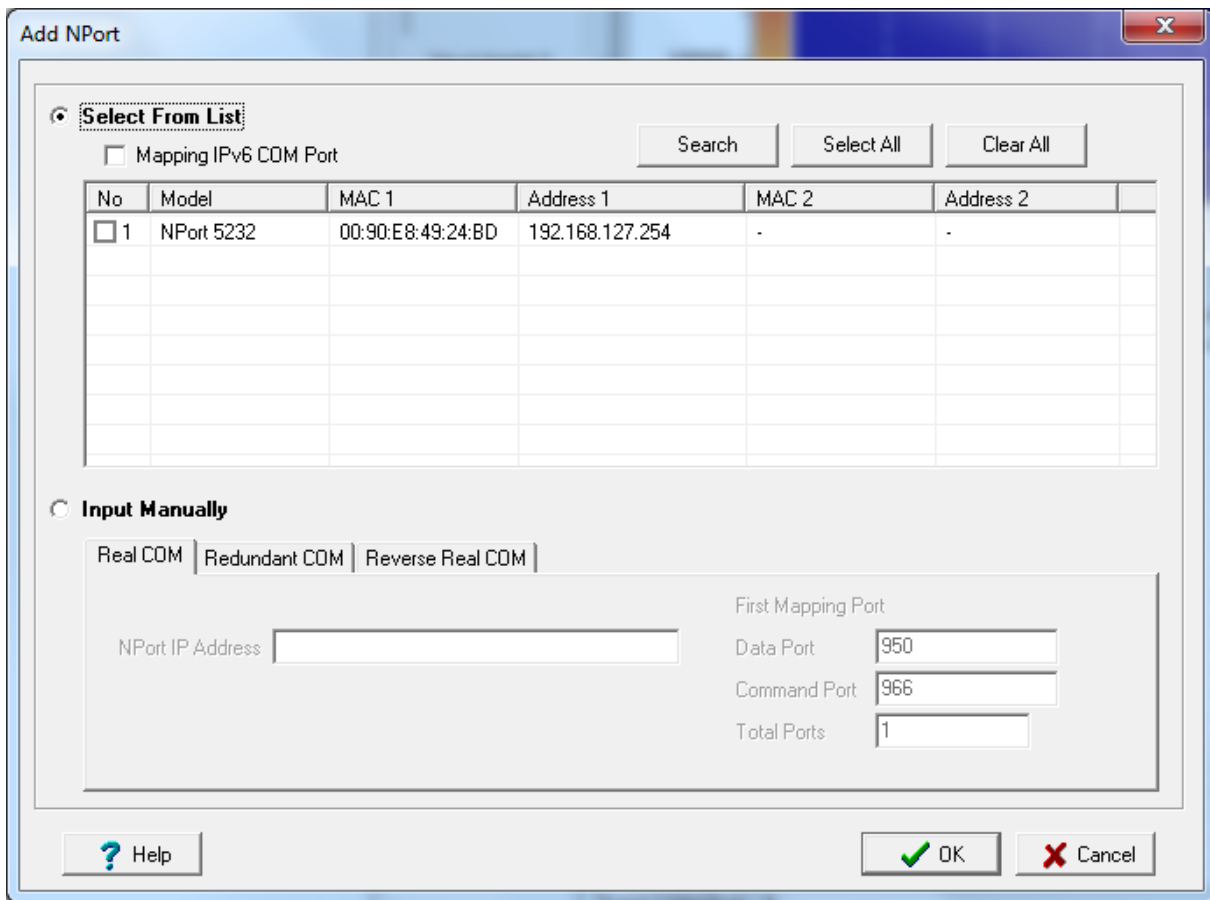

The created COM ports show in Windows Device Manager.

Entering TCP Client Mode

To enter TCP Client Mode:

1. Select **Operating Settings**.
2. Select a port.
3. In **Operation Mode**, select **TCP Client Mode**.

The screenshot shows the Moxa NPort Web Console interface. The browser address bar shows the URL 192.168.127.254. The page title is "MOXA www.moxa.com". The left sidebar contains a "Main Menu" with options: Overview, Basic Settings, Network Settings, Serial Settings, Operating Settings (selected), Accessible IP Settings, Auto Warning Settings, Monitor, Change Password, Load Factory Default, and Save/Restart. The main content area is titled "Operating Settings" and is for "Port 01". The "Operation mode" is set to "TCP Client Mode". Other settings include: TCP alive check time (0), Inactivity time (0), Ignore jammed IP (No), Packing length (0), Delimiter 1 (0), Delimiter 2 (0), Delimiter process (Do Nothing), and Force transmit (0). The "TCP Client Mode" section includes: Destination IP Address (4001), Designated Local Port 1 (5011), Designated Local Port 2 (5012), Designated Local Port 3 (5013), Designated Local Port 4 (5014), and Connection control (Startup/None). A "Submit" button is at the bottom.

Operating Settings		Port 01
Operation mode	TCP Client Mode	
TCP alive check time	0	(0 - 99 min)
Inactivity time	0	(0 - 65535 ms)
Ignore jammed IP	<input checked="" type="radio"/> No <input type="radio"/> Yes	
Data Packing		
Packing length	0	(0 - 1024)
Delimiter 1	0	(Hex) <input type="checkbox"/> Enable
Delimiter 2	0	(Hex) <input type="checkbox"/> Enable
Delimiter process	Do Nothing (Processed only when Packing length is 0)	
Force transmit	0	(0 - 65535 ms)
TCP Client Mode		
Destination IP Address		
Destination IP address 1	4001	
Destination IP address 2	4001	
Destination IP address 3	4001	
Destination IP address 4	4001	
Designated Local Port 1	5011	(0 - 65535, 0 represents assigned automatically.)
Designated Local Port 2	5012	(0 - 65535)
Designated Local Port 3	5013	(0 - 65535)
Designated Local Port 4	5014	(0 - 65535)
Connection control	Startup/None (Connect on/Disconnect by)	
<input type="checkbox"/> Apply the above settings to all serial ports		
<input type="button" value="Submit"/>		

4. In **Destination IP address 1**, type your destination address and port. You can add four destinations.
5. Click **Submit**.

Entering UDP Mode

To enter UDP mode:

1. Select **Operating Settings**.
2. Select a port.
3. In **Operation Mode**, select **UDP Mode**.

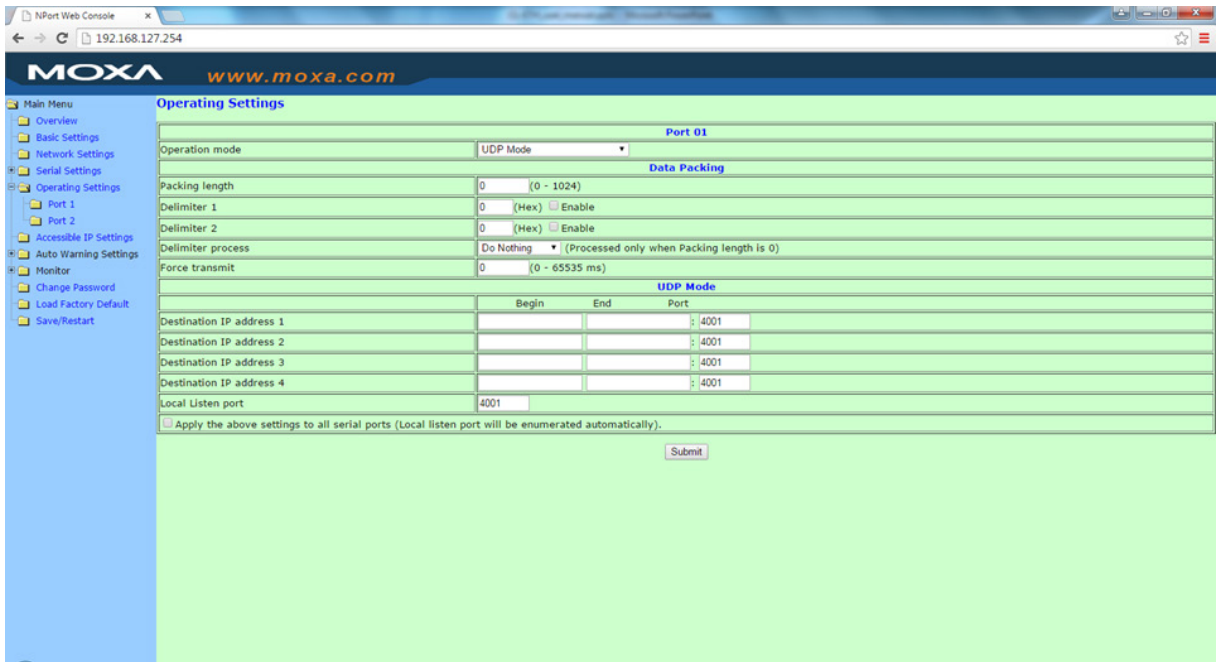

4. In **Destination IP address 1**, type your destination address and port. You can add four addresses.
5. Click **Submit**.

Factory Settings of User Programmable Parameters

Table 6 lists the factory defaults of user-programmable parameters. The prevailing parameter settings of CL31 can be seen with the following command:

```
get params parameter_group
```

The user-programmable parameters can be changed with the following command:

```
set parameter_group parameter
```

Table 6 Factory Defaults of User-Programmable Parameters

Parameter	Factory Default
Control blower	Auto
Control inheater	Auto
Data_acq power_save	Disabled
Data_port baud	19200
Data_port mode	RS232
Data_port parity	8N1
Maint_port baud	9600
Maint_port parity	8N1
Message angle_corr	On
Message transmission	Periodic
Message secondary transmission	None
Message transmission delay	100 ms
Message height_offset	0
Message interval	2 s
Message secondary interval	2 s
Message port	Data
Message profile scale	1.0
Message profile noise h2	Off
Message type	msg2_base
Message secondary type	None
Message units	Feet
Message vv_limit ceiling	2000 m (6562 ft)
Oper_mode	Normal
Port_timeout	2 min
Unit_id	0 (zero)
Echo	On

This page intentionally left blank.

CHAPTER 4

FUNCTIONAL DESCRIPTION

This chapter provides information on the measurement principles of the product.

Theory of Operation

Basic Operating Principle

The operating principle of CL31 is based on the measurement of the time needed for a short pulse of light to traverse the atmosphere from the transmitter of the ceilometer to a backscattering cloud base and back to the receiver of the ceilometer.

The general expression connecting time delay (t) and backscattering height (h) is

$$h = ct/2$$

where c is the speed of light ($c = 2.99 \times 10^8$ m/s).

A reflection from 25,000 ft can be seen by the receiver after

$$t = 50.9 \mu\text{s}$$

Practical Measurement Signal

Generally, particles at all heights scatter light, so the actual return signal may look like that shown in Figure 17 below.

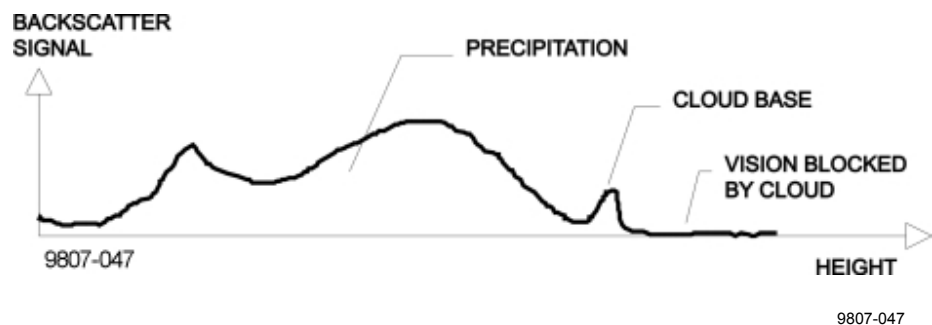

Figure 17 Typical Measurement Signal

The instantaneous magnitude of the return signal provides information on the backscatter properties of the atmosphere at a certain height. Information about fog and precipitation, as well as clouds, can be derived from the return signal. Fog and precipitation attenuate the return signal from a cloud. However, fog and precipitation backscatter signals also provide data that can be used in estimating this attenuation and computing the necessary compensation, up to a limit.

In its normal full-range operation, CL31 digitally samples the return signal from 0 to 50 μ s. The sampling is repeated every 33 or 67 ns, providing a spatial resolution of 5 or 10 meters respectively from ground level up to 7 700 meters. This resolution is adequate for measuring the atmosphere, since visibility in the densest clouds is of the same order.

Noise Cancellation

For safety and economic reasons, the transmitted laser power is so low that the noise of the ambient light exceeds the backscattered signal. To overcome this, a large number of laser pulses are sent, and the return signals are summed. The desired signal can be multiplied by the number of pulses, whereas noise, being random, partially cancels itself. The degree of cancellation for white (Gaussian) noise equals to the square root of the number of samples; thus, the resulting signal-to-noise ratio improvement is equal to the square root of the number of samples. However, this processing gain cannot be extended endlessly since the environment changes and, for example, clouds move.

Return Signal Strength

In general form, the instantaneous return signal power can be derived from the Lidar equation:

$$P_r(z) = E_o \cdot \frac{c}{2} \cdot \frac{A}{z^2} \cdot \beta(z) \cdot e^{-2 \int_0^z \sigma(z') dz'}$$

where

- $P_r(z)$ = Instantaneous power received from distance z
- E_o = Effective pulse energy (taking all optics attenuation into account) [Ws]
- c = Speed of light [m/s]
- A = Receiver aperture [m²]
- z = Distance [m]
- $\beta(z)$ = Volume backscatter coefficient at distance z [m⁻¹srad⁻¹, srad = steradian]
- $e^{-2 \int_0^z \sigma(z') dz'}$ = Two-way atmospheric transmittance, accounts for the attenuation of transmitted and backscattered power. The transmittance equals 1 in clear atmosphere, that is, with no attenuation.

Height Normalization

Assuming a clear atmosphere, the power of the return signal (P_r) is inversely proportional to the square of the distance, that is, the signal strength from 1 000 ft is generally hundred times stronger than from 10 000 ft.

The height dependence is eliminated by multiplying the measured signal value with the square of height (height normalization). Noise, however, being height-independent from a measurement point of view, is then correspondingly accentuated with increasing height.

Backscatter Coefficient

The volume backscatter coefficient, $\beta(z)$, represents the portion of light reflected back towards the ceilometer from a distance z (for example, from water droplets). A dense cloud gives a stronger reflection. This can be expressed as follows:

$$\beta(z) = k \cdot \sigma(z)$$

where

k = Proportionality constant [1/srad].

$\sigma(z)$ = Extinction coefficient (the attenuation factor in forward direction) [1/m].

The extinction coefficient relates to *visibility* in a straightforward manner. If visibility is defined according to a 5 % contrast threshold (World Meteorological Organization definition for Meteorological Optical Range, MOR, equals daylight *horizontal* visibility), then the extinction coefficient is the following:

$$\sigma = 3 / V$$

where

V = MOR visibility (5 % contrast) [m]

The proportionality constant, k , also called the Lidar Ratio, has been subjected to a lot of research. Although the Lidar Equation can be solved without knowing the ratio, it must remain constant with the height if accurate estimates of the extinction (or visibility) profile are to be made.

It has been discovered that in many cases, k can be assumed to equal 0.03, tending to be lower (down to 0.02) in high humidity, and higher (up to 0.05) in low humidity conditions. However, in precipitation conditions, k can have a wider range of values.

Assuming k value of 0.03 srad^{-1} , visibility in clouds in the range of 15 to 150 m (50 to 500 ft), gives the following range for β :

$$\beta = 0.0006 \dots 0.006 \text{ m}^{-1}\text{srad}^{-1} = 0.6 \dots 6 \text{ km}^{-1}\text{srad}^{-1}$$

Vertical Visibility

Any fog, precipitation, or similar obstruction to vision between the ground and the cloud base may attenuate the cloud base signal and produce backscatter peaks that far exceed that from the cloud. Virtually any backscatter height profile is possible, up to some physical limits. To distinguish a significant cloud return signal, the attenuation of, for example, fog or precipitation, has to be taken into account by normalizing with regard to extinction. The profile thus obtained is proportional to the extinction coefficient at various heights, and enables the use of fairly straightforward threshold criteria to determine what cloud is and what it is not.

By assuming a linear relationship between backscatter and extinction coefficient according to the previous formula and by assuming that the ratio, k , is constant over the observation range, it is possible to obtain an extinction coefficient profile through a mathematical computation. This is also called inverting the backscatter profile, and it basically answers the question of what kind of an extinction coefficient profile would produce the measured backscatter profile.

No assumption as to the absolute value of the ratio, k , needs to be made if k is constant in terms of height. The assumptions that have to be made are fairly truthful, and accurate enough for cloud detection purposes.

The backscatter profile inversion is also independent of several instrumental uncertainties including transmitted power and receiver sensitivity.

An estimate of vertical visibility can easily be calculated from the extinction coefficient profile because of the straightforward extinction coefficient-to-visibility relationship, assuming a constant contrast threshold. Visibility is simply the height where the integral of the extinction coefficient profile, starting from the ground, equals the natural logarithm of the contrast threshold, sign disregarded.

Tests and research have, however, shown that the 5 % contrast threshold widely used for horizontal measurement is unsuitable for vertical measurement if values close to those estimated by a ground-based observer are to be obtained.

CL31 uses a contrast threshold value which, through many tests, has been found to give vertical visibility values closest to those reported by ground-based human observers. A safety margin is obtained with regard to pilots looking down in the same conditions since the contrast between objects, especially runway lights, is much more distinct on the ground.

Sky Condition Algorithm

General

The Vaisala CL31 Sky Condition algorithm uses a time series of ceilometer data to calculate the cloud layer height and the amount of clouds in different layers. The purpose of the algorithm is to construct an image of the whole sky based on ceilometer measurements from a single point. The sky condition information is included in data message 2 and its subclass. The algorithm can report up to five cloud layers below 25 000 feet.

When using emulation message of the CT25K message 6, sky condition information can be displayed with the DD50 Digital Display. The emulation message reports up to four different cloud layers below 25 000 feet.

Option code

The sky condition algorithm is included in software versions 1.50, and later. You can activate the algorithm by entering an option code number to the ceilometer. The option code number is based on the CL31 ceilometer serial number. If CL31 is purchased with the sky condition activated, this has already been done at the factory. In case the sky condition option is purchased afterwards, you can find out the serial number by entering the following command:

```
CEILO > system

Vaisala Ceilometer CL31

Unit ID:      0
Serial Nro:  421202
SW Version:  1.500

HW Options
Modem:       N/A
Humitter:    N/A
```

The ceilometer serial number can also be found in the label on the measurement unit door. Send the CL31 serial number to Vaisala, and Vaisala returns the option code, for example, 63273 (see the example in the next section, Activation).

Activation

After you have received the option code, activate the sky condition algorithm as follows:

```
CEILO > advanced
Service password accepted.
```

```
CEILO > set option sky_cond on 63273
OK.
```

Select the sky condition message type (msg2_base or its subclass) to be reported:

```
CEILO > set message type msg2_base
OK
CEILO>close
```

Algorithm Overview

The sky condition algorithm is calculated every five minutes based on data collected during the last 30 minutes. The last 10 minutes are double-weighted to make the algorithm more responsive to variations in cloudiness.

Operation of the sky condition algorithm is shown in Figure 18 on page 56. Instead of forming a histogram of hit heights, the algorithm uses both height and timing information to find hits close to each other. These hits are combined into clusters and a height value is calculated for each cluster. This height gives the base height of a cloud or cloud layer represented by the cluster. The algorithm reports layers by combining clusters whose heights are close to each other and then selecting clusters that cover the greatest amount of sky.

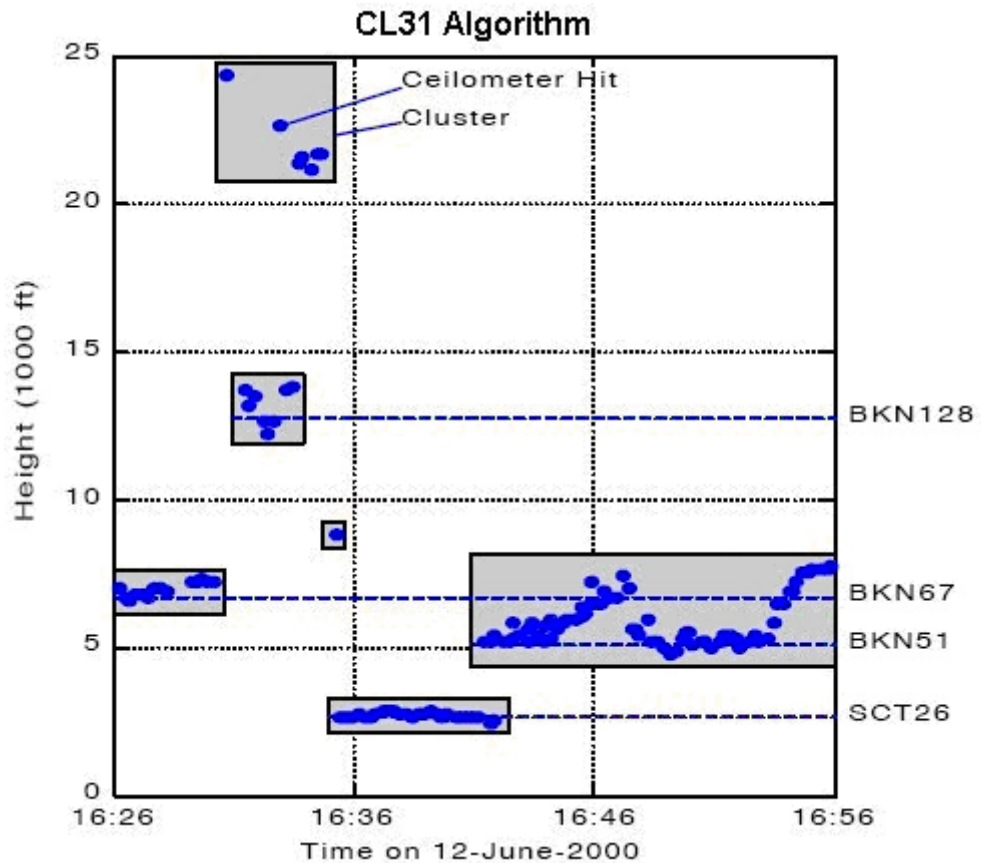

0911-075

Figure 18 Basic Operation of CL31 Sky Condition Algorithm in a 2D Time-Height Domain

The sky condition algorithm reports the total sky cover in octas with values between 0 and 9. (One octa equals one eighth.) Value 9 is reported only in a vertical visibility condition. In addition, the sky cover can have values of -1 and 99. The -1 is reported if the data is missing or the ceilometer is in stand-by mode. The value 99 is reported after the start-up of the ceilometer indicating there is not enough data for algorithm processing.

Table 7 Sky Cover Values from the Sky Condition Algorithm

Volume	Sky cover
0-8	Cloudiness in octas
9	Vertical Visibility (VV)
-1	Data missing or ceilometer in stand-by
99	Not enough data

Vertical Visibility (VV) hits are considered as cloud hits if they are above 2 000 meters. The cloud height is defined as (VV + signal range) /2. Lower VV hits are assigned to a VV register during the last 10 minute period. If the percentage of VV hits in the register exceeds 50 %, the sky condition algorithm reports VV. The VV height is the average height of

the VV hits. Otherwise, the lower hits are also considered as normal cloud hits with cloud height (VV + signal range) of /2, that is, VV hits are assigned to cloud height categories.

The sky condition algorithm has been implemented using five independent modules. The algorithm control flow is shown below.

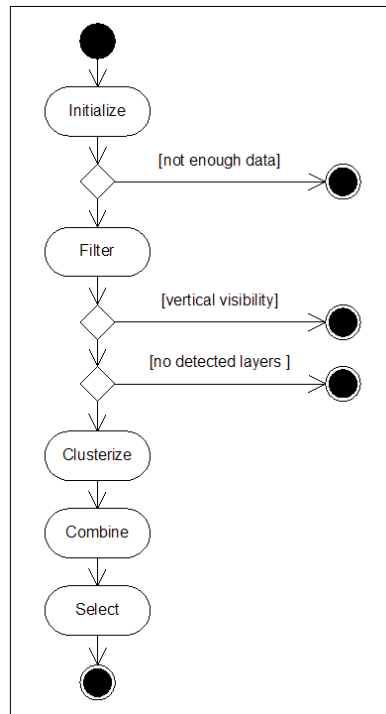

Figure 19 Control Flow of Sky Condition Algorithm

In the control flow, the **Initialize** module selects ceilometer measurements from the last 30 minutes, sorts them into time order and distributes them into specific data structures. After the ceilometer measurements have been distributed, the module checks if the ceilometer has provided enough data for the algorithm. Two ratios are calculated: ratio of measurements during the last 30 minutes and ratio of measurements during the last few minutes. If either of these ratios exceeds a threshold value, the data is marked valid and will be used by the rest of the algorithm. Both of these ratios require a fixed sampling period that is automatically detected from the measurements. If there is no valid ceilometer data, 99 is returned as sky cover value, and if more than 30 minutes has elapsed, -1 is returned as sky cover value.

The **Filter** module converts ceilometer measurements into cloud hits. If the ceilometer measurement contains multiple cloud bases, the conversion results in multiple cloud hits. Vertical visibility measurements are also converted into cloud hits. After ceilometer measurements have been converted, the amount of clear sky, the amount covered by cloud hits and the amount covered by high clouds are determined for the unit. Total sky cover is adjusted using the value received from the **Initialize**

module. The adjusted total sky cover gets the value of 8 only if no clear sky was detected and the measurements do not have any features that indicate there is no overcast condition.

The **Clusterize** module combines hits into clusters. First the cloud hits are combined into clusters, using an algorithm that looks for layers where the horizontal difference between consecutive hits is small, and then by algorithm that allows large height differences between consecutive hits. These two algorithms are needed to make sure that in simple cases, separate layers are not combined and in difficult cases the algorithm does not report too many layers. After all hits have been combined into clusters, a height is assigned for each cluster. First, the height below which 10 % of all hits within the cluster are, is selected. Then, the height of the cluster is calculated as an average of selected hits around this height.

The **Combine** module combines clusters into a single list of layers. The module goes through all possible layer heights. A cover value is calculated for each height. The calculated value is the sum of the cover values of those clusters whose base height is between the height of the layer and the height of the layer plus vertical extent of the layer. Vertical extent of the layer is 100 feet or 10 % of the height of the layer, whichever is bigger. The height that has the largest cover value is used in forming a new layer. The height of the new layer is equal to a weighed sum of those clusters that were within the vertical extent of the layer. After the layer has been formed, the clusters are deleted and if there are any uncombined clusters left, the process is repeated.

The **Select** module chooses the layers to be reported by the algorithm. The first step is to assign high cloud cover to a single cloud layer. If the highest layer is above the threshold height, high cloud cover is assigned to that layer; otherwise a synthetic layer is created at 25 000 feet. The second step is to determine which layer to report as the lowest one. After the lowest layer has been determined, the **Select** module rounds layer heights into 100 feet precision. Layers closer than 100 feet to the layer that is below them or whose sky cover is 1/16 or lower (less than 1/2 octas) are combined with the layers that are immediately below them. The height of the combined layer is the height of the lower layer. If the number of layers is still more than the number of layers requested, the algorithm combines the layer which covers the least amount of sky to the layer that is below it. This is done as many times as necessary to reduce the number of layers to the requested number. The lowest layer is not checked in either of the above two conditions.

The last phase of the **Select** module is to calculate the cumulative cloud cover for the reported layers. This value is the sum of the sky cover of the layer and all the layers below it converted into integer octas. The cumulative cover of 8 octas is only reported if the layer is the highest layer and if the total sky cover from the **Select** module is 8 octas.

CHAPTER 5

OPERATION

This chapter contains information on operating CL31.

Operation Modes

There are two operation modes: normal and standby. The **set oper_mode normal** and **set oper_mode standby** commands are used to switch between the modes. In the normal mode, continuous measurement and message transmission occurs according to the chosen parameters. The standby mode, which involves turning off the wearing parts, can be used during periods when measurement is not needed.

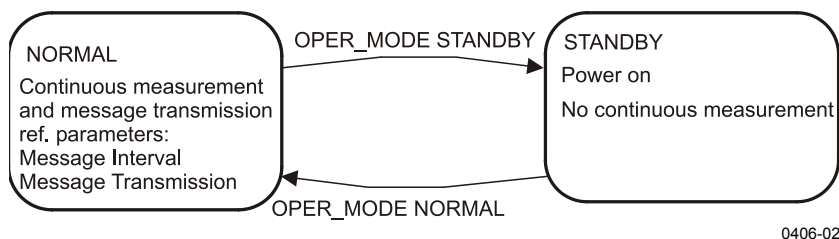

Figure 20 Operation Modes

Serial Lines - Open and Closed Port

There are two line outputs in CL31, the maintenance line (external connector J4) and the data line (external connector J3). The data line is used for measurement data communication and can be operated through a modem or a serial line (RS-232 or RS-485). The maintenance line is intended for on-site maintenance access, and is used only as a RS-232 serial line. Functionally the operation of the two lines is identical, that is, the same commands, operations, and messages operate through both lines.

The factory default setting:

- 8 data bits,
- No parity
- 1 stop bit and 9 600 bps (for maintenance line)
- 19 200 bps (for data line).

The bit rate can be selected from the user menu.

The lines use the 7-bit USASCII character format. Both the UPPER and lower letter cases can be used.

The standard operation of the serial lines requires no handshake signals.

A communication port, in other words the serial line, has the following two internal states (see Figure 21 on page 61).

- **CLOSED**: This is the transmitting state of a measurement data message. In this state, messages are transmitted as a response to a polling input string or automatically at predetermined intervals, depending on the settings (message transmission). User commands are not accepted, except for the **open** command, which turns the line into the OPEN state.
- **OPEN**: This is the user dialog state. In this state, the device responds to user commands and command input is echoed. A command prompt `CEILO >` is displayed to indicate that CL31 is ready for command input from the user. The commands are executed by pressing ENTER, for example, `OPEN 1 <enter>`. No automatic transmission of the measurement data message is executed in the open state. The port reverts to the closed state with the **close** command. An automatic, 2-minute time-out after the last character input is applied. A 2 to 30-minute time-out may be set with the **set port_timeout** command. Command input echoing can be turned on or off by giving the command "set echo on/off". When turned off, typed characters are not echoed, but the command responses are given normally. As default echoing is on.



Only one of the ports can be open for commands at a time. Only one of the ports transmits measurement messages at a time. Additionally, in the RS-485 mode, a unit ID must be given with the **open** command.

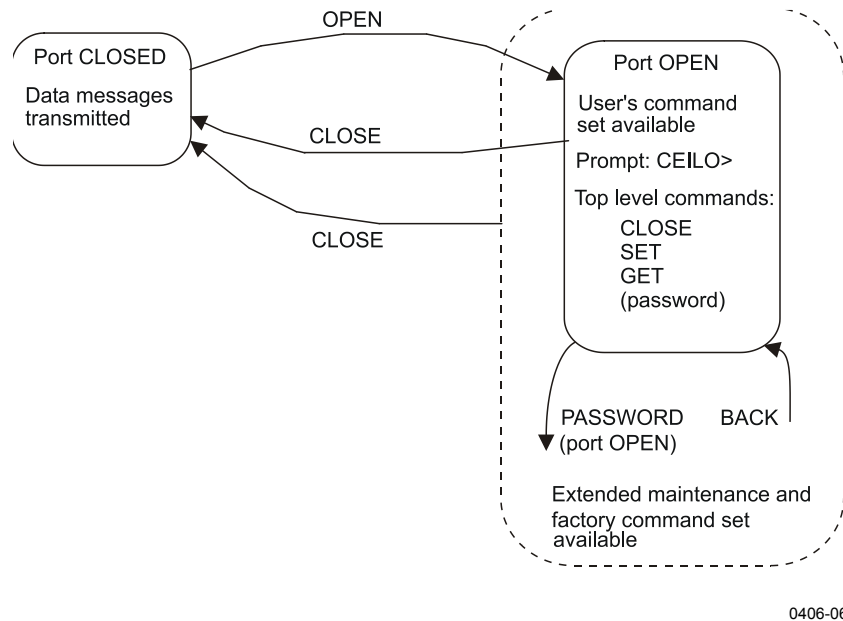

Figure 21 Open and Closed Port

User Commands

User commands are described in Table 8 on page 62. To access user commands, open the line with **open**. No password is needed.

The exact format of commands does not have to be remembered, as the command line interpreter provides interactive support. At each menu level, pressing ENTER provides an output of the available menu. Inserting a letter followed by ENTER outputs all commands starting with that letter. Inserting two letters followed by ENTER outputs all commands that start with those two letters, and so on, until only the desired command is left. This command is then executed by pressing ENTER.

In addition to the user menu and the user level command set, there is a second in-depth maintenance and service level menu and command set, which is intended for more profound system changes and diagnostics. These advanced level commands are presented in Table 9 on page 65. The password for this level is "advanced". The commands on this level should only be used according to the instructions in this manual.

Table 8 User Level Commands

Command	Description
close	Closes a user interface. Releases a port for message transmission.
get diag contamination	Prints diagnostic history of window contamination.
get diag angle	Prints diagnostic history of inclinometer angle.
get diag battery	Prints diagnostic history of battery voltage.
get diag int_temp	Prints diagnostic history of internal temperature.
get diag l_power	Prints diagnostic history of laser power.
get diag l_temp	Prints diagnostic history of laser temperature.
get failure history	Prints history of alarm and warning status.
get failure status	Shows active alarms and warnings.
get params data_acq	Prints data-acquisition related parameters.
get params factory	Prints factory calibration values.
get params message	Prints message related parameters.
get params port	Prints serial port and modem parameters.
get sensors	Prints data-acquisition values, tilt angles, and humidity, if available.
get temperatures	Displays temperatures.
get uptime	Displays uptime clock.
get voltages	Displays voltages.
name	Displays device type, name, and ID.
open	Opens a user interface.
reset	Resets the ceilometer using the watchdog reset.
set control blower on	Sets the window blower on.
set control blower off	Sets the window blower off.
set control blower manual	Sets manual control.
set control blower auto	Sets automatic control.
set control inheater on	Sets inheater on.
set control inheater off	Sets inheater off.
set control inheater manual	Sets manual control.
set control inheater auto	Sets automatic control.
set control outheater on	Sets outheater on.
set control outheater off	Sets outheater off.
set data_port baud 115.2 k	Data serial port speed
set data_port baud 57.6 k	Data serial port speed
set data_port baud 38.4 k	Data serial port speed
set data_port baud 19.2 k	Data serial port speed
set data_port baud 9600	Data serial port speed
set data_port baud 4800	Data serial port speed
set data_port baud 2400	Data serial port speed
set data_port baud 1200	Data serial port speed
set data_port baud 300	Data serial port speed
set data_port mode RS-232	Data serial port mode
set data_port mode RS-485	Data serial port mode
set data_port parity 7E1	Data serial port settings
set data_port parity 7O1	Data serial port settings
set data_port parity 7N2	Data serial port settings
set data_port parity 8N1	Data serial port settings

Command	Description
set defaults	Restores the following default settings: Operation mode: normal Measurement mode: standard Data acquisition autoadjustments: on Blower control: auto Inheater control: auto Diagnostics intervals: 2 min Power-save mode: disabled Power-save sleep interval: 60 s Message angle correction: on Message transmission: periodic Message secondary transmission: none Message transmission delay: 100 ms Message height-offset: 0 Message interval: 2 s Message secondary interval: 2 s Manual message: disabled Message port: data Message profile scale: 1.0 Message profile noise-h2: off Message type: msg2_base Message secondary type: none Message units: feet Message VV limit ceiling: 6562 ft (2000 m) Port timeout: 2 min Unit ID: 0 Echo: on
set diag interval angle	Sets diagnostic-data logging interval (min). 0 disables.
set diag interval battery	Sets diagnostic-data logging interval (min). 0 disables.
set diag interval contam	Sets diagnostic-data logging interval (min). 0 disables.
set diag interval int_temp	Sets diagnostic-data logging interval (min). 0 disables.
set diag interval I_power	Sets diagnostic-data logging interval (min). 0 disables.
set diag interval I_temp	Sets diagnostic-data logging interval (min). 0 disables.
set diag clear	Clears all diagnostic-data history.
set echo on	Sets command input echoing on.
set echo off	Sets command input echoing off.
set failure history clear	Clears failure history.
set maint_port baud 115.2 k	Maintenance serial port speed.
set maint_port baud 57.6 k	Maintenance serial port speed.
set maint_port baud 38.4 k	Maintenance serial port speed.
set maint_port baud 19.2 k	Maintenance serial port speed.
set maint_port baud 9600	Maintenance serial port speed.
set maint_port baud 4800	Maintenance serial port speed.
set maint_port baud 2400	Maintenance serial port speed.
set maint_port baud 1200	Maintenance serial port speed.
set maint_port baud 300	Maintenance serial port speed.
set maint_port parity 7E1	Maintenance serial port settings
set maint_port parity 7O1	Maintenance serial port settings
set maint_port parity 7N2	Maintenance serial port settings
set maint_port parity 8N1	Maintenance serial port settings

Command	Description
set message transmission delay	Sets request-based delivery response delay (ms).
set message transmission periodic	Sets periodic message transmission.
set message transmission request	Sets message request-based delivery.
set message interval 2 ... 120	Sets message delivery interval in seconds.
set message port data	Delivers messages into data port.
set message port maintenance	Delivers messages into maintenance port.
set message secondary interval	Sets secondary message delivery interval in seconds.
set message secondary transmission none	Disables secondary message.
set message secondary transmission periodic	Sets periodic secondary message transmission.
set message secondary transmission request	Sets secondary message request-based delivery.
set message secondary type	Sets secondary message types, as in "set message type" (see below).
set message type msg1_10x770	Sets Msg1 with 10x770 profile.
set message type msg1_20x385	Sets Msg1 with 20x385 sample profile with 385 samples and 20 m resolution.
set message type msg1_5x1500	Sets Msg1 with 5x1500 profile.
set message type msg1_5x770	Sets Msg1 with 5x770 profile.
set message type msg1_base	Sets Msg1 without a profile.
set message type msg2_10x770	Sets Msg2 with 10x770 profile.
set message type msg2_20x385	Sets Msg2 with 20x385 profile.
set message type msg2_5x1500	Sets Msg2 with 5x1500 profile.
set message type msg2_5x770	Sets Msg2 with 5x770 profile.
set message type msg2_base	Sets Msg2 without a profile.
set message type status	Sets status message.
set message type ct25k_msg1	Sets CT25K message 1.
set message type ct25k_msg6	Sets CT25K msg6 / CT25KAM msg60.
set message type ct25k_msg61	Sets CT25KAM msg61.
set message type ct12k_dmsg2	Set CT12K message no. 2.
set message type ct12k_dmsg3	Set CT12K message no. 3.
set message type ld40_std_tg	Sets LD40 Standard Telegram.
set name <string>	Sets the unit name.
set oper_mode standby	Sets standby mode. Profile sampling is inactive.
set oper_mode normal	Sets normal operation.
set port_timeout 0 ... 30	Sets the command line time-out to 0 ... 30 minutes. Zero disables.
set unit_id <character>	Sets the unit ID.
status	Prints the status message.
system	Lists system information: type, ID, SW version, HW modules, serial number.
version	Displays the SW version.

Table 9 **Advanced Level Commands**

Command	Description
back	Go back one security level. Go back to the user level commands.
dump	Outputs all settings and diagnostics data. Includes the responses of the following commands: system, status, get failure status, get failure history, get params factory, get params message, get params port, get params algorithm, and get failure diag.
get failure diag	Show failure diagnostics data.
get params algorithm	Prints cloud algorithm related parameters.
service replace_instr battery	Prints service instructions for replacing a battery.
service replace_instr cle_engine_board	Prints service instructions for replacing a CLE321 engine board.
service replace_instr clp_ac_power	Prints service instructions for replacing a CLP321 power unit.
service replace_instr clr_receiver	Prints service instructions for replacing a CLR321 receiver.
service replace_instr clt_transmitter	Prints service instructions for replacing a CLT321 transmitter.
service self_check	Runs the self-check.
service spare_part cle_engine mark	Marks CLE spare part status.
service spare_part cle_engine clear	Clears CLE spare part status.
service spare_part clt_transmitter mark	Marks CLT spare part status.
service spare_part clt_transmitter clear	Clears CLT spare part status.
service spare_part show_state	Shows spare part status of CLE and CLT.
service sw_update	Updates the software.
set data_acq autoadj on	Sets SW-control of data acquisition parameters.
set data_acq autoadj off	Disables SW-control of data acquisition parameters.
set data_acq meas_mode standard	Maximum range 7700 m, 10 m resolution, laser pulse rate 10 kHz.
set data_acq meas_mode high_res	Maximum range 7550 m, 5 m resolution, laser pulse rate 8 kHz.
set data_acq power_save disable	Disables power-save mode.
set data_acq power_save enable	Enables power-save mode.
set data_acq power_save interval 30 ... 30000	Power-save interval in seconds. Default is 60.
set data_acq receiver gain low	Sets receiver to low gain.
set data_acq receiver gain high	Sets receiver to high gain.
set data_acq transmit length_of_p short	Sets transmitter to short pulse.
set data_acq transmit length_of_p long	Sets transmitter to long pulse.
set data_acq transmit inlaser 0 ... 4095	Sets control value for laser pulse.
set factory calibr_outlaser	Starts automatic calibration of target outlaser.
set factory cross_talk	Calibrates factory crosstalk.
set factory opt_sensit	Sets optics sensitivity.
set factory outlaser 0 .. 2500	Sets target outlaser.
set factory receiver_type clr311	Sets receiver type to CLR311
set factory receiver_type clr321	Sets receiver type to CLR321
set factory win_clean	Sets window clean status for window cond. calibration.
set message angle_corr on	Heights in messages are corrected for the tilt angle.
set message angle_corr off	Heights in messages are not corrected for the tilt angle.

Command	Description
set message height_offset <value>	Sets height offset in current units. (Range is -304 ... 304 m or -1000 ... 1000 ft.) Positive values are added to and negative values are subtracted from the measured height.
set message manual_msg <string>	Sets a manual message. Empty string disables.
set message profile scale	Scaling factor for range gate data (%).
set message profile noise_h2 on	Range gates data is always range normalized, even noise.
set message profile noise_h2 off	Range gates data is range normalized, if backscatter is contained.
set message units feet	Reported heights unit is feet.
set message units meters	Reported heights unit is meters.
set message vv_limit ceiling	Sets vertical visibility ceiling limit (meters/feet). No vertical visibility will be reported above this limit. (Default: 2000 m).
set option humitter on	Enables the humitter option.
set option humitter off	Disables the humitter option.
set option sky_cond off	Disables the sky condition option.
set option sky_cond on 0 .. 99999	Enables the sky condition option with an activation code.

Data Messages

To ease the use of CL31 and to ease the transfer from old ceilometer versions to the new one, CL31 includes data messages used in CT12K, CT25K, CT25KAM, and LD40. CL31 provides the following data messages:

- CL31 Data messages 1 and 2
- CL31 Status message
- CT12K data messages No. 2 and No. 3
- CT25K data messages No. 1 and No. 6
- CT25KAM data messages No. 60 and No. 61
- LD40 Standard Telegram

Each port can be set to transmit a specified message automatically. Alternatively, the port can be set to transmit the set message only when polled by a predetermined polling string of characters, or the polling string can contain the message identification.

The messages may provide a different resolution and require a different measurement mode. A change of a message always switches into a correct measurement mode automatically.

However, CL31 Status message and CL31 Data messages 1 and 2 of subclass 5 (without profile data) may be used in both 10 m and 5 m resolutions. A selection of these messages always activates the 10 m resolution (standard mode). If needed, users can change into the 5 m resolution (high resolution) by typing the following advanced level command: **set data_acq meas_mode high_res**. Thus, the above messages will work in 5 m resolution.



All characters are 7-bit USASCII.

↵ symbolizes Carriage Return + Line Feed (2 characters) throughout this document.

Start-of-Header, Start-of-Text, End-of-Text, End-of-Transmission, Carriage Return, and Line Feed are non-printing characters in most practical terminal use.

Secondary message

Two different messages can be separately output on the two ports. This is enabled by configuring a secondary message using the command “set message secondary”. The secondary message is always output to the other port, meaning that the port is not configured for the primary message. Note that if both messages contain a backscatter profile, then the message intervals should not be set to values lower than 4 seconds.

CL31 Data Messages No. 1 and 2

Data message No. 1 contains cloud height/vertical visibility measurement and elementary status information that enables a host system or operator to see that no warnings or alarms are present. This message also includes a range and sensitivity normalized backscatter profile that is suitable, for example, for a graphical data presentation or research purposes. In addition to the content of data message No. 1, data message No. 2 also includes sky condition data.

The data resolution is 5 m/10 m/20 m (16 ft/33 ft/66 ft) in distance, and 20 bits (five hex-ASCII characters) in signal magnitude.

An example of CL31 data message No.1 is presented below:

☎CLA10011☎J	1st line	12 char.
30 01230 12340 23450 FEDCBA987654J	2nd line	35 char.
00100 10 0770 098 +34 099 12 0621 L0112HN15 139J	3rd line	49 char.
00000111112222233333 ... (5 x 770 bytes)J	4th line	3852 char.
☎1a3f♦J	5th line	8 char.
	Total	3956 char.

An example of CL31 data message No. 2 is presented below:

☎CLA10021☎J	1st line	12 char.
30 01230 12340 23450 FEDCBA987654J	2nd line	35 char.
3 055 5 170 0 /// 0 /// 0 ///J	3rd line	37 char.
00100 10 0770 098 +34 099 12 0621 L0112HN15 139J	4th line	49 char.
00000111112222233333 ... (5 x 770 bytes)J	5th line	3852 char.
☎1a3f♦J	6th line	8 char.
	Total	3993 char.

For data lines with low bandwidth, there is also a base version of each message. In the short version of message No.1, lines 3 and 4 are left out. In the base version of message No.2, lines 4 and 5 are left out. In the table below, the data message types are summarized with the minimum bit rates and storage capacity. The examples are divided into measurement resolutions of 10 m and 5 m. They have minimum reporting intervals of 2 s and 3 s, respectively.

Table 10 Messages with 10 m Resolution (Standard Mode)

Message Number and Subclass	Message Name	Length (bytes)	Min bps (2 s)	Data/Month (2 s)	Min bps (12 s)	Data/Month (12 s)
11	msg1_10x770	3956	28.8k	4890 MB	4800	815 MB
12	msg1_20x385	2031	14.4k	2510 MB	2400	418 MB
15	msg1_base	55	300	68 MB	300	11 MB
21	msg2_10x770	3993	28.8k	4940MB	4800	423 MB
22	msg2_20x385	2068	14.4k	2560 MB	2400	425 MB
25	msg2_base	92	600	114 MB	300	19 MB

Table 11 Messages with 5 m Resolution (High Resolution)

Message Number and Subclass	Message Name	Length (bytes)	Min bps (3 s)	Data/Month (3 s)	Min bps (15 s)	Data/Month (15 s)
13	msg1_5x1500	7606	28.8k	6267 MB	9600	1253 MB
14	msg1_5x770	3956	14.4k	3260 MB	4800	625 MB
15	msg1_base	55	300	45 MB	300	9 MB
23	msg2_5x1500	7643	28.8k	6230 MB	9600	1260 MB
24	msg2_5x770	3993	14.4k	3290 MB	4800	660 MB
25	msg2_base	92	600	76 MB	300	15 MB

The interpretation of the message lines is as follows:

1ST LINE

Example: ☎CLA10011☺↵

where

☎	=	Start-of-Heading character
CL	=	Ceilometers' identification string; always CL
A	=	Unit identification character 0 ... 9, A ... Z
100	=	Software level ID 100 ... 999
1	=	Message number; message without sky condition data is = 1, with sky condition data is = 2
1	=	Character for subclasses of message 1 = 10 m x 770 samples, range 7700 m (<i>msg1_10x770</i>) 2 = 20 m x 385 samples, range 7700 m (<i>msg1_20x385</i>) 3 = 5 m x 1500 samples, range 7500 m (<i>msg1_5x1500</i>) 4 = 5 m x 770 samples, range 3850 m (<i>msg1_5x770</i>) 5 = without a backscatter profile
☺	=	Start-of-Text Character
↵	=	Carriage Return + Line Feed

2ND LINE

Example: 30 01230 12340 23450 FEDCBA987654J

where

3	=	Detection status:	Detection status as follows:
		0	No significant backscatter
		1	One cloud base detected
		2	Two cloud bases detected
		3	Three cloud bases detected
		4	Full obscuration determined but no cloud base detected
		5	Some obscuration detected but determined to be transparent
		/	Raw data input to algorithm missing or suspect
0	=	W & A information:	Warning and Alarm information as follows:
		0	Self-check OK
		W	At least one Warning active, no Alarms
		A	At least one Alarm active
01230	=	Lowest cloud base height Vertical Visibility as calculated /////	If detection status is 1, 2, or 3 If detection status is 4 If detection status is 0 or 5
12340	=	Second lowest cloud base height Highest signal detected /////	If detection status is 2 or 3 If detection status is 4 If detection status is 0, 1, or 5
23450	=	Highest cloud base height /////	If detection status is 3 If detection status is 0, 1, 2, 4, 5
FEDC BA98 7654	=	Alarm (A), Warning (W), and internal status (S) information. Each character is a hexadecimal representation of four bits, that is, values between 0 and 9 are presented with numbers and values 10, 11, 12, 13, 14, and 15 are presented with letters A, B, C, D, E, and F, respectively. As each of the 12 characters represent the sum of four individual bits, the total number of bits is 48 (b00-b47), with the following breakdown and interpretation:	
	F:	b47 (8000 0000 0000)	Transmitter shut-off (A)
		b46 (4000 0000 0000)	Transmitter failure (A)
		b45 (2000 0000 0000)	Receiver failure (A)
		b44 (1000 0000 0000)	Voltage failure (A)
	E:	b43 (0800 0000 0000)	(Spare) (A)
		b42 (0400 0000 0000)	Memory error (A)

	b41	(0200 0000 0000)	Light path obstruction (A)
	b40	(0100 0000 0000)	Receiver saturation (A)
D:	b39	(0080 0000 0000)	(spare) (A)
	b38	(0040 0000 0000)	(spare) (A)
	b37	(0020 0000 0000)	(spare) (A)
	b36	(0010 0000 0000)	(spare) (A)
C:	b35	(0008 0000 0000)	(spare) (A)
	b34	(0004 0000 0000)	(spare) (A)
	b33	(0002 0000 0000)	Coaxial cable failure (A)
	b32	(0001 0000 0000)	Ceilometer engine board failure (A)
B:	b31	(0000 8000 0000)	Window contamination (W)
	b30	(0000 4000 0000)	Battery voltage low (W)
	b29	(0000 2000 0000)	Transmitter expires (W)
	b28	(0000 1000 0000)	High humidity (W)
A:	b27	(0000 0800 0000)	(spare) (W)
	b26	(0000 0400 0000)	Blower failure (W)
	b25	(0000 0200 0000)	(spare) (W)
	b24	(0000 0100 0000)	Humidity sensor failure (W)
9:	b23	(0000 0080 0000)	Heater fault (W)
	b22	(0000 0040 0000)	High background radiance (W)
	b21	(0000 0020 0000)	Ceilometer engine board failure (W)
	b20	(0000 0010 0000)	Battery failure (W)
8:	b19	(0000 0008 0000)	Laser monitor failure (W)
	b18	(0000 0004 0000)	Receiver warning (W)
	b17	(0000 0002 0000)	Tilt angle > 45 degrees warning (W)
	b16	(0000 0001 0000)	(spare) (W)
7	b15	(0000 0000 8000)	Blower is on (S)
	b14	(0000 0000 4000)	Blower heater is on (S)
	b13	(0000 0000 2000)	Internal heater is on (S)
	b12	(0000 0000 1000)	Working from battery (S)
6	b11	(0000 0000 0800)	Standby mode is on (S)
	b10	(0000 0000 0400)	Self-test in progress (S)
	b09	(0000 0000 0200)	Manual data acquisition settings are effective (S)
	b08	(0000 0000 0100)	(spare) (S)
5	b07	(0000 0000 0080)	Units are meters if on, else feet (S)
	b06	(0000 0000 0040)	Manual blower control (S)
	b05	(0000 0000 0020)	Polling mode is on (S)
	b04	(0000 0000 0010)	(spare) (S)
4	b03	(0000 0000 0008)	(spare) (S)
	b02	(0000 0000 0004)	(spare) (S)
	b01	(0000 0000 0002)	(spare) (S)
	b00	(0000 0000 0001)	(spare) (S)

For example, if no clouds are detected, if the window is contaminated, the battery voltage is too low, the internal heater is on and units are meters, a warning is given, and the second line appears as follows:

```
0W  /////  /////  /////  0000C0002080
```

ADDITIONAL 3RD LINE IN MESSAGE NO. 2

Example: 3 055 5 170 0 /// 0 /// 0 ///┘



The line starts with two space characters.

where

- | | |
|--|---|
| <p>3 = Detection status:
 0 ... 8
 9
 -1
 99</p> | <p>Cloud coverage of the first layer in octas
 Vertical visibility
 Data missing, sky condition option not active or ceilometer in standby mode
 Not enough data (after start-up)</p> |
| <p>055 = Height of the 1st cloud layer (550 m or 5500 ft depending on the units selection)</p> | |
| <p>5 = Cloud amount of the 2nd layer in octas</p> | |
| <p>170 = Height of the 2nd cloud layer (1700 m or 17000 ft depending on the selection)</p> | |
| <p>0 = Cloud amount of the 3rd layer in octas</p> | |
| <p>/// = Height of the 3rd cloud layer</p> | |
| <p>0 = Cloud amount of the 4th layer in octas</p> | |
| <p>/// = Height of the 4th cloud layer</p> | |
| <p>0 = Cloud amount of the 5th layer in octas</p> | |
| <p>/// = Height of the 5th cloud layer</p> | |

The reporting resolution is 10 m or 100 ft depending on the unit's selection. If the cloud amount is zero, the corresponding layer height is ///.

3RD LINE (4TH LINE IN MESSAGE NO. 2)

Example: 00100 10 0770 098 +34 099 12 621 L0112HN15 139␣

where

- 00100 = Parameter SCALE, 100 (%) is normal (0 ... 99999 possible)
- 10 = Backscatter profile resolution in meters.
- 0770 = Length of the profile in samples 385, 770, 1400, or 1500
- 098 = Laser pulse energy, % of nominal factory setting
(0 ... 999)
- +34 = Laser temperature in degrees C (-50 ... +99)
- 099 = Window transmission estimate % (0 ... 100)
- 12 = Tilt angle, degrees from vertical (0 ... 90)
- 0621 = Background light, millivolts at internal ADC input
(0 ... 2500)
- L0112 = Measurement parameters (pulse Long/Short, pulse qty 0112x1024, gain
HN15 High/Low, bandwidth Narrow/Wide, sampling 15/30 MHz)
L = Long pulse
0112 = Pulse quantity
H = High gain
N = Narrow bandwidth
15 = 15 MHz sampling rate
- 139 = SUM of detected and normalized backscatter,
0 ... 999. Multiplied by scaling factor times 10^4 . At scaling factor 1.0 the SUM
range 0 ... 999 corresponds to integrated backscatter 0...0.0999 srad^{-1} .



The next line is omitted if the message subclass is 5.

4TH LINE (5TH LINE IN MESSAGE NO. 2)

Example: 00000111112222233333.....␣(5 x 770 bytes)

The two-way attenuated backscatter profile with sensitivity normalized units $(100000 \cdot \text{srad} \cdot \text{km})^{-1}$ unless otherwise scaled with the *SCALE* parameter. Each sample is coded with a 20-bit HEX ASCII character set; msb nibble and bit first, 2's complement. The length of this line is equal to 5 times the length of the profile + 2. Note that the profile is not corrected with the tilt angle.

Using the *SCALE* parameter a total dynamic range of 29 bits can be achieved for this message.

The line ends with Carriage Return and Line Feed characters.



The next line is omitted if the message subclass is 5.

5TH LINE (6TH LINE IN MESSAGE NO. 2)

Example: Ⓣ1a3f◆↵

where

Ⓣ = End-of-Text character
 1a3f = Checksum, see below for calculation procedure
 ◆ = End-of-Transmission character
 ↵ = Carriage Return + Line Feed

CRC16 Checksum

The CRC16 checksum can be calculated using the following algorithm written in the C programming language:

```

/* 16-bit type. */
typedef unsigned short Word16;

/* Calculate CRC-16 value as used in CL31. */
Word16 crc16(const unsigned char *buf, int len)
{
    Word16 crc;
    Word16 xmask;
    int    i, j;

    crc = 0xffff;

    for (i = 0; i < len; ++i)
    {
        crc ^= buf[i] << 8;

        for (j = 0; j < 8; ++j)
        {
            xmask = (crc & 0x8000) ? 0x1021 : 0;
            crc <<= 1;
            crc ^= xmask;
        }
    }

    return crc ^ 0xffff;
}

```

The calculation of the checksum starts after the Start-of-Heading character and ends after the End-of-Text character, that is, the first character included is C and the last one included is End-of-Text.

CL31 Status Message

The Status message displays the internal monitoring of the entire unit. It is mainly meant for testing and maintenance purposes. The Status message can be displayed by giving the **status** command.

An example of the status message is presented below:

```

☎CL0100S0☺↓
10 00850 // // // // // 0000000000080↓

Alarms↓
  Tmit Shutoff  OK      Transmitter  OK↓
  Receiver      OK      Voltages     OK↓
  Ext Memory    OK      Light Pth Obs OK↓
  Rec Saturat   OK      Coaxial Cable OK↓
  Engine        OK

Oper Mode:  normal   Autoadj:   on↓
Meas Mode:  standard Interval:  2.0 s↓
Power Save: disabled Sleep Int: 60 s↓

Transmitter      Receiver↓
  Pulse Len: long   Gain:         high↓
  Inlaser:  1745    Bandwidth: narrow↓
  Pulse Cnt: 16384  Smpl Rate: 15 MHz↓
  Pulse Frq: 10.0 kHz↓

Window Cnd: 100 %   Outlaser:  1064↓
Backg Rad:  2.4     103 %↓

Tilt Angle: 0.4    Humidity:  N/A↓

Temperatures↓
  Internal:  23.7    External:  8.7↓
  DC Power:  22.6    Inclinom:  28.9↓
  Laser:     25.6    Blower:    8.3↓

Internal heater: off (auto)
Blower:         on (auto)
Blower heater:  on
Batt Use:       off

System Status:  OK↓
Suspect Module: none↓
☺↓

```

Message interpretation:

1ST LINE

The first line of the CL31 status message is structurally identical to the first line of the CL31 data message No. 1 (see section CL31 Data Messages No. 1 and 2 on page 68), except that the second to last character that identifies the message number, is always S0☺↵.

2ND LINE

The second line of the CL31 status message is structurally identical to the second line of the CL31 data message No. 1 (see section CL31 Data Messages No. 1 and 2 on page 68).

LINES 4 ... 9

Lines four to nine display the alarm status of Ceilometer CL31. If an alarm is present, CL31 invalidates the cloud data.

11TH LINE

Line 11 displays the operation mode and autoadjustment settings of the CL31. In normal use, the operation mode should be set to **normal** and autoadjustment should be set to **on**.

12TH LINE

Line 12 displays the measurement mode and measurement interval settings of the CL31. In normal use, the measurement mode should be set to **standard**. By default the measurement interval is 2.0 s.

13TH LINE

Line 13 displays the power-save mode status and sleep interval settings of the CL31. In normal use, the power-save mode is **disabled**. If the power-save mode is on, the sleep interval indicates the interval when the CL31 does not measure.

LINES 15 ... 19

Lines 12 to 16 display the transmitter and receiver settings of the CL31.

Transmitter	Pulse Len	=	Pulse length, long in normal use (100 ns)
	Inlaser	=	Controls the peak laser power
	Pulse Cnt	=	Pulse count, the number of pulses during a single measurement cycle, 16384 by default
	Pulse Frq	=	Laser pulsing frequency (10.0 kHz)
Receiver	Gain	=	High by default, may be low in fog or heavy snow
	Bandwidth	=	Narrow by default
	Smpl Rate	=	Receiver signal sampling rate, defines the vertical resolution of the measurement. Default is 15 MHz which corresponds to a 10 m resolution.

21ST LINE

Line 21 displays the window contamination status and outlaser settings of the CL31. The estimated transparency of 90 % to 100 % means that the window is clean. It is recommended that the window is cleaned whenever there is a window contamination warning, that is, the transparency is estimated as 70 % or lower.

Outlaser is the laser pulse energy measured with CLM311 Laser Monitor Board. The value underneath the outlaser value (on line 17) refers to the percentage of the laser power relative to the factory setting. The embedded software will maintain this value between 95 % and 105 %.

22ND LINE

Line 22 displays the background radiance value of the CL31. The background radiance varies according to the background illuminance condition and temperature. The following values, outlaser percentage, is described above.

24TH LINE

Line 24 displays the tilt angle in degrees from vertical. Humidity measurement is visible if the option is activated.

LINES 26 ... 29

Lines 26 to 29 display temperature values in degrees centigrade. These values are used for the automatic control of the internal heaters and the blower, and for status monitoring.

LINES 31 ... 34

Lines 31 and 34 display the status of the internal heater, the blower, the blower heater, and the battery.

36TH LINE

Line 36 displays a summary of the system status. It should be **OK**. Alternatively, it can display the texts **Warning** or **Alarm/Fail**, if there are warnings or alarms present.

37TH LINE

Line 37 displays the automatic diagnosis in case of a failure. The system suggests a module to be replaced. If there is a secondary option, it will be stated in parentheses.

38TH LINE

Example: ⊙↵

where

- ⊙ = End-of-Text character
- ↵ = Carriage Return + Line Feed

CT12K Messages

Ceilometer CL31 also includes two Ceilometer CT12K messages. These are digital message No.2 and digital message No.3.

CT12K Digital Message No. 2

This message contains detailed range gate data, and internal monitoring data for the most important variables.

An example of digital message No.2 is presented below:

```

☎␣
10 04200 00150 // // 0000011010 ␣
2 0 0.08 36 0 100 23.9 0.00 0 0 ␣
0DD .....DD ␣
-1 ␣
-2 ␣
-3 ␣
-4 ␣
-5 ␣
-6 (data values;) ␣
-7 ␣
-8 ␣
-9 ␣
10 ␣
11 ␣
12DD.....DD ␣
☎␣

```

ON/OFF data is 1/0 accordingly. Other data is decimal or hexadecimal numbers. The total length of the message is 636 characters. The printout is 15 lines, the width is max 44 characters, of which 42 are visible.

Message Interpretation:

1ST LINE

Example: ☎␣

where

☎ = Start-of-Heading character
␣ = Carriage Return + Line Feed

2ND LINE

The first line of the message is status line 1. Status line 1 is identical in all CT12K messages.

Example:

NSB H₁H₁H₁H₁H₁ T₁T₁T₁T₁T₁ H₂H₂H₂H₂H₂ T₂T₂T₂T₂T₂ S₁S₂S₃S₄S₅S₆S₇S₈S₉S₁₀↓

where

- N = 0 No significant backscatter (clear air)
 1 One layer detected
 2 Two layers detected
 3 Sky is fully obscured but no cloud base can be detected from echo signal received (for example, fog or precipitation)
 4 Sky is partially obscured and no cloud base is detected
- S = 0 No CL31 alarm is active
 1 Alarm is active
- B = Space if S = 0
 'bel' character if S = 1. Because 'bel' is a nonprinting character, the alarming line appears one character shorter in a printout than normally.
- N = 0 / 4 H₁=H₂=T₁=T₂= ////
 1 / 2 H₁H₁H₁H₁H₁ = The lowest detected cloud height in 5 digits. Leading zeroes not suppressed.
 T₁T₁T₁T₁T₁ = Range of backscatter of first layer, //// if not defined
 2 H₂H₂H₂H₂H₂ = Second cloud height, //// if not defined
 T₂T₂T₂T₂T₂ = Range of backscatter of second layer, //// if not defined
 3 H₁H₁H₁H₁H₁ = Calculated vertical visibility
 T₁T₁T₁T₁T₁ = Signal range, that is, height of highest detected backscatter
- S₁ = An alarm or a warning is active
 S₂ = Voltage alarm
 S₃ = Transmitter alarm or transmitter expires warning
 S₄ = Transmitter shutoff alarm (Laser temperature too high)
 S₅ = High radiance warning
 S₆ = Blower On
 S₇ = Heater On
 S₈ = 0 Unit is feet
 1 Unit is meters
 S₉ = 0 Always (Data type in internal table. N/A)
 S₁₀ = 0 Always (Fast Heater Off is active. N/A)

3RD LINE

The second line of the message is status line 2.

Example: G F N.NN SUM IIN LAS TLx OF.FS XX PP,↓

where

G	=	0	Low gain
		2	High gain
F	=	0	Always (Laser pulse frequency. N/A)
N.NN	=		Background radiance/100. One digit, two decimals.
SUM	=		Sum of total backscattered power per unit solid angle, that is, range and instrument normalization applied. Three digits, no decimals. Leading zeroes replaced by space characters.
IIN	=	0	Always (Algorithm related internal processing information. N/A) 3 digits
LASE	=		Measured laser power in percentages of current laser power of target laser power (LLAS). 3 digits.
TL.x	=		Internal variable indicating transmitter temperature. Two digits, one decimal; preceded by minus sign if negative. Degrees Celsius.
OF.FS	=	0.00	Always (Offset of zero signal. N/A) Two digits, two decimals.
XX	=	0	Always (Algorithm related internal processing information. N/A) Two digits.
PP	=	0	Always (A two-digit number representing calculated extinction coefficient values. N/A)

LINES 4 ... 16

Lines 3 to 15 are the data lines of the message.

Example: HHD₀D₁D₂D₃ D₉,↓

where

HH	=	Height of the first value
D	=	Data values

The data is scaled to a hexadecimal number 0 ... FE (decimal 0 ... 254). Overflow is indicated by FF. A leading zero is replaced by a space character.

Data values are presented for each 50 ft range gate. The height of the first value in the line in thousands of feet. Two digits, a leading zero is replaced by a space. Twenty 50 ft values per line starting with 0 (ft), next line 1 000 (ft). 13 lines altogether. Last line (12 000 ft) has 10 values.

CT12K Digital Message No. 3

This message contains Status Line 1 identical to Message No. 2 (see section CT12K Digital Message No. 2 on page 78) and one single range gate data line indicating the presence or absence of backscatter in each range gate.

An example of digital message No.3 is presented below:

```

☎␣
10 04200 00150 // // // // // 0000011010 ␣
0001FFF800000000000007A000.....000 ␣
Ⓞ␣
    
```

ON/OFF data is 1/0 accordingly. Other data is decimal or hexadecimal numbers. The total length of the message is 112 characters. The printout is 2 lines, the maximum width is 66 characters, of which 64 are visible. The time for message transmission at 300 baud is 3.73 s.

Message Interpretation:

1ST LINE

Example: ☎␣

where

- ☎ = Start-of-Heading character
- ␣ = Carriage Return + Line Feed

2ND LINE

The first line of the message is status line 1. Status line 1 of digital message No.3 is identical to that of message No. 2 (see section CT12K Digital Message No. 2 on page 78).

3RD LINE

The second line of the message is a backscatter data line.

Example: D₁D₂D₃D₄.....D₆₄↵

where

- D = A single, ASCII coded hexadecimal character O ... F, where each bit of the 4-bit nibble of the hex character expressed in a binary form represents one range gate.
- D₁ = Represents the four lowest 15 m (approximately 50 ft) range gates, that is, 45 m (appr. 0 ft, 50 ft, 100 ft, 150 ft).
- D₂ = Represents the four next ones, that is, 60 m (appr. 200 ft, 250 ft, 300 ft, 350 ft), etc.
- 0 Indicates no detectable backscatter in four adjacent range gates
- F Indicates backscatter in all four range gates
- 8 Indicates backscatter in the lowest range gate only
- 1 Indicates backscatter in the highest range gate only

All other characters indicate a gate-by-gate combination of backscatter according to the binary nibble, converted to hexadecimal.

CT25K Data Messages

Ceilmeter CL31 includes two Ceilmeter CT25K data messages. These are data message No. 1 and data message No. 6.

CT25K Data Message No. 1

This message is intended for cloud height/vertical visibility measurement when no other measurement information is desired. The message includes the most elementary status information, which enables a host system or operator to see that no warnings or alarms are present. An example of data message No.1 is presented below:

☎CTA2010☉↵	1st line	11 char.
30 01230 12340 23450 FEDCBA98↵	2nd line	31 char.
☉↵	3rd line	3 char.

	total 44 characters	

The transmission time and size is the following:

0.18 s at 2 400 bps (10-bit char.)

10.6 Kbytes/h, 253 Kbytes/d, 7.6 Mbytes/mo. at 4 msg./min., uncompressed.

Message interpretation:

1ST LINE

Example: ☎CTA2010☺┘

where

- ☎ = Start-of-Heading character
- CT = Ceilometers' identification string; always CT
- A = Unit number 0 ... 9, A ... Z
- 20 = Software level id 00 ... 99
- 1 = Message number; this message is always = 1
- 0 = Spare character for future subclasses of message
- ☺ = Start-of-Text Character

2ND LINE

Example: 30 01230 12340 23450 FEDCBA98┘

Second line of CT25K data message No. 1 is identical to that of CL31 data message No. 1 (see section CL31 Data Messages No. 1 and 2 on page 68), except for the status bit string, which is 4-byte hex coded. The status bit string is coded as follows:

where

FEDC = Alarm (A), Warning (W), and internal status information. Each character is a
 BA98 = hexadecimal representation of four bits, that is, values between 0 and 9 are presented with respective numbers and values 10, 11, 12, 13, 14, and 15 are presented with letters A, B, C, D, E, and F respectively. As each character represents the sum of four individual bits, the total number of bits is 32 (b00-b31), with the following breakdown and interpretation:

- F: b31 (8000 0000) Transmitter shut-off (Laser temperature high.) (A)
- b30 (4000 0000) Transmitter failure (A)
- b29 (2000 0000) Receiver or coaxial cable failure (A)
- b28 (1000 0000) Engine, voltage or memory failure (A)
- E: b27 (0800 0000) (spare) (A)
- b26 (0400 0000) (spare) (A)
- b25 (0200 0000) (spare) (A)
- b24 (0100 0000) (spare) (A)
- D: b23 (0080 0000) Window contaminated (W)
- b22 (0040 0000) Battery low (W)
- b21 (0020 0000) Transmitter expire warning (W)
- b20 (0010 0000) Heater or humidity sensor failure (W)
- C: b19 (0008 0000) High radiance warning together with b02 (W)
- b18 (0004 0000) Engine, receiver, or laser monitor failure warning (W)

	b17	(0002 0000)	Relative Humidity is high > 85 % (option) (W)
	b16	(0001 0000)	Light path obstruction or receiver saturation (also receiver failure active, b29) (A)
B:	b15	(0000 8000)	Blower failure (W)
	b14	(0000 4000)	(spare) (W)
	b13	(0000 2000)	(spare) (W)
	b12	(0000 1000)	(spare) (W)
A:	b11	(0000 0800)	Blower is ON
	b10	(0000 0400)	Blower heater is ON
	b09	(0000 0200)	Internal heater is ON
	b08	(0000 0100)	Units are METERS if ON, else FEET
9:	b07	(0000 0080)	Polling mode is ON
	b06	(0000 0040)	Working from battery
	b05	(0000 0020)	Always 0 (Single sequence mode is. N/A)
	b04	(0000 0010)	Always 0 (Manual settings are effective. N/A)
8:	b03	(0000 0008)	Tilt angle is > 45 degrees (W)
	b02	(0000 0004)	High radiance warning together with b19. (W)
	b01	(0000 0002)	Manual blower control
	b00	(0000 0001)	(spare)

3RD LINE

☺␣ = End-of-Text and Carriage Return + Line Feed

CT25K Data Message No. 6

Message number 6 is similar to message number 1 but extended with a sky condition line. For an interpretation, see section Sky Condition Algorithm on page 54.

The following is an example of message number 6 format:

☺CTA2060☺␣	1st line	11 char.
30 01230 12340 23450 FEDCBA98␣	2nd line	31 char.
3 055 5 170 0 /// 0 ///␣	3rd line	30 char.
☺␣	4th line	3 char.

total 75 characters		

The transmission time and size is the following:

total 75 characters

=> 0.31 s at 2400 bps (10 bit char.)

=> 18.0 Kbytes/h, 432 Kbytes/d, 12.7 Mbytes/mo. at 4 msg/min,
uncompressed

Message interpretation:

LINES 1 and 2 are identical to that of Message number 1.

LINE 3

Example: 3 055 5 170 0 /// 0 ///

Note that the string begins with 2 spaces.

where

- 3 = The first number of line: detection status as follows:
 - 0 ... 8 Cloud amount of the first layer in octas.
 - 9 Vertical visibility.
 - 1 Data missing or the ceilometer is in standby mode.
 - 99 Not enough data (after start-up).
- 055 The second number of line: Height of the 1st cloud layer (5500 ft or 550 m depending on feet or meter selection).
- 5 The third number of line: Cloud amount of the 2nd layer in octas.
- 170 The fourth number of line: Height of the 2nd cloud layer (17000 ft or 1700 m depending on feet or meter selection).
- 0 The fifth number of line: Cloud amount of the 3rd layer in octas.
- /// The sixth number of line: Height of the 3rd cloud layer.
- 0 The seventh number of line: Cloud amount of the 4th layer in octas.
- /// The eighth number of line: Height of the 4th cloud layer.

The reporting resolution is 100 ft or 10 m depending on feet or meter selection. If the cloud amount is zero, the corresponding layer height is ///.

CT25KAM Data Messages

Ceilometer CL31 includes two Ceilometer CT25KAM data messages. These are data message No. 60 and data message No. 61.

CT25KAM Data Message No. 60

CT25KAM message number 60 is identical to CT25K message number 6. See section CT25K Data Message No. 6 on page 85.

CT25KAM Data Message No. 61

CT25KAM message number 61 is similar to CT25KAM message No. 60 (and CT25K message No. 6) but extended with a fifth layer in the sky condition line. An example of data message No. 61 is presented below:

☎CTA2061☺␣	1st line	11 char.
30 01230 12340 23450 FEDCBA98␣	2nd line	31 char.
3 055 5 170 0 /// 0 /// 0 ///␣	3rd line	37 char.
☺␣	4rd line	3 char.

	total	82 characters

The transmission time and size is the following:

total 82 characters
 => 0.34 s at 2400 baud (10-bit char.)
 => 20.4 Kbytes/h, 490 Kbytes/d, 14.6 Mbytes/mo. at 4 msg/min,
 uncompressed

LD40 Standard Telegram

Ceilometer CL31 includes one Ceilometer LD40 data message. This is the standard telegram 'X1TA'. This message is given in clear text and includes cloud heights and additional meteorological data, date, time, sensor address, and status information of the instrument.

An example of the 'X1TA' telegram and a message interpretation are presented below:

```
☺X1TA_8_015_00.00.00_00:00_00875_11150_NODET_0100_0325_NOD
T_11300_11600_+025_ft_01_00000000_96 ↵ ☺
```

Where

☺	=	Start-of-text character
X	=	Sensor type (X LD40)
1	=	Sensor ID number (0 to 9..ABC..MN)
TA	=	Text telegram
8	=	Instrument type, Always 8 = LD40
015	=	Telegram update time or message interval in seconds
00.00.0	=	Always (Date N/A)
0		
00:00	=	Always (Time N/A)
00875	=	First cloud layer
11175	=	Second cloud layer
NODE	=	Third cloud layer (in this case: not detected)
T		
0100	=	Penetration depth of laser beam into first cloud layer
0325	=	Penetration depth of laser beam into second cloud layer
NODT	=	Penetration depth of laser beam into third cloud layer
11300	=	Vertical visibility
11600	=	Maximum range of detection
+025	=	Cloud height offset (in this case the ceilometer is situated 25 ft above the runway level)
f	=	Dimensions of all values between byte 26 and byte 76 (ft or m_)
00	=	Always (Precipitation index. N/A)
000000	=	System status and messages
00		
96	=	Checksum (This value is only an example; the correct value may be different from this one.)
↵	=	Carriage return + Line feed
☺	=	End-of-transmission character



The notation '_' stands for a space character.

Telegram Structure Remarks

- a. Spaces (20 hex) always appear with the following bytes: 5, 7, 11, 20, 26, 32, 38, 44, 49, 54, 59, 65, 71, 76, 79, 82, 91.

The only other byte that may contain a <SPACE>, is byte 78, provided that the dimension is in meters.

Numbers are always given with the leading zeros as in bytes 27 to 31 in the example.

- b. NODET (and NODT) indicates that the value in question has not been detected because, for example, there was only one cloud layer or no cloud layer at all.

Like any measured value, NODET also contains information about the result of the measurement.

NODET may appear instead of cloud layers, minimum vertical extensions of clouds, and vertical visibility.

- c. When bytes 83 to 90 signal an CL31 alarm, all cloud detection values within the telegram are replaced by minus signs (-, 2D Hex). For example:
----- is shown instead of bytes 27 to 31.
- d. All values given are height above the runway level; Ceilometer CL31 itself might be located above or below the runway level. Therefore, byte 72 must always contain a sign byte, either + or -.

Failure and Warning Messages

Bytes 83 to 89 of the LD40 standard telegram indicate warnings and errors. A '0' signifies that no error of that error group has happened.

An alarm causes data telegrams to contain invalid data. A warning status does not cause invalid data.

The following tables describe how CL31 is mapped to the LD40 error groups. See Table 12 on page 90 for the definition of the different error groups.

Table 12 Error Group Definition

Error Group	Byte No.	Description
1	83	Engine board and voltages
2	84	Light path, receiver saturation and window condition
3	85	Receiver and coaxial cable
4	86	Transmitter
5	87	Memory failure and general warnings
6	88	Temperature regulation
7	89	Always 0. Not used.

Tables from Table 13 to Table 19 describe the single error codes in different error groups.

Table 13 Error Group 1 (Byte 83)

Error Code	Description
0	Status OK
1	Engine or voltage failure (A)
2	Not used
3	Not used
4	Not used
5	Not used
6	Not used

Table 14 Error Group 2 (Byte 84)

Error Code	Description
0	Status OK
1	Light path obstruction (A) or Window contamination warning (W)
2	Receiver saturation (A)

Table 15 Error Group 3 (Byte 85)

Error Code	Description
0	Receiver OK
1	Not used
2	Not used
3	Not used
4	Receiver failure (A) or Coaxial cable failure (A) or Receiver warning (W)
5	Not used
6	Not used

Table 16 Error Group 4 (Byte 86)

Error Code	Description
0	Transmitter OK
1	Transmitter expires (laser power low) (W)
2	Transmitter failure
3	Not used
4	Not used
5	Not used
6	Transmitter shutoff (laser temperature too high) (A)

Table 17 Error Group 5 (Byte 87)

Error Code	Description
0	Status OK
1	Laser monitor failure (W) or Blower failure (W) or High radiation warning (W) or Engine warning (W) or Tilt angle warning (angle is > 45 degrees) (W) or Battery voltage low (W) or Battery failure (W) or Humidity high (option) (W) or Humidity Sensor failure (option) (W)
2	Not used
3	Memory failure (A)
4	Not used

Table 18 Error Group 6 (Byte 88)

Error Code	Description
0	Temperature regulation OK
1	Heater failure (W)

Table 19 Error Group 7 (Byte 89)

Error Code	Description
0	Always 0 (Data transmission. N/A)
1	Not used
2	Not used
3	Not used
4	Not used
5	Not used
6	Not used
7	Not used
8	Not used

Checksum Calculation

The checksum of a data or a command telegram is calculated by computing the sum of all signs (alphanumeric signs and control codes such as STX, EOT CR, LF, except the checksum bytes itself), building the two's complement and taking the lower byte of this result.

The higher half-byte and the lower half-byte - converted to a visible ASCII character - is the checksum.

See the following example with the **polling** command:

Telegram:

STX H0C!X1P-----83 EOT

1. Compute the sum:

$$\begin{aligned} \text{Sum} &= \text{STX} + \text{'H'} + \text{'0'} + \text{'C'} + \text{'!'} + \text{'X'} + \text{'1'} + \text{'P'} \\ &+ 10 \times \text{'-'} + \text{EOT} \end{aligned}$$

$$\begin{aligned} \text{Sum} &= 0x02 + 0x48 + 0x30 + 0x43 + 0x21 + 0x58 \\ &+ 0x31 + 0x50 + 10 \times 0x2D + 0x04 \end{aligned}$$

$$\text{Sum} = 0x037D \text{ HEX} = 893 \text{ DEZ}$$

2. Build the two's complement:

The two's complement is built by inverting the binary representation of the sum and adding 1:

$$\begin{aligned} 2\text{Com} &= \neg \text{Sum} + 1 = \neg 0x037D + 0x01 = 0x0C83 \text{ HEX} \\ &= 3203 \text{ DEZ} . \end{aligned}$$

3. Take lower byte and build ASCII-character:

The lower byte of 2Com is 0x83 HEX, so the high byte of the checksum is 8 and the low byte is 3:

$$\text{Checksum} = 83$$

Manual Message

The ceilometer can be set to transmit user defined cloud heights and status information. You can set a cloud message in the format of line 2 of any real cloud message (for example, Message No. 1 or CT25K data message). The message is a string and the maximum length is 33 characters. If the length is less than 33 characters, the remaining length is padded with spaces. (The CT25K messages use only 29 characters). The end of a string is determined by a new line and the leading spaces are omitted. This message is volatile. The manual message command is behind the password "advanced". Below is an example of a manual message:

```
CEILO > advanced
Service password accepted.
CEILO > set message manual_msg 30 00200 01000 05000
000000000000
OK
```

The **get params message** command displays the current manual message.

To return to the normal messages, give an empty string:

```
CEILO > set message manual_msg

OK
```

The manual message is intended for testing purposes. After reset, the normal message takes effect.

Polling Mode

A port can be set to transmit a message only when polled by a predetermined polling string of characters. The polling string can contain the message identification.



Ceilometer CT12K messages cannot be polled.

The CL31 unit can be assigned an identification of one-character digit or letter. The factory setting is 0 (zero).

The polling mode is activated with the following command:

```
CEILO > set message transmission request
```

Returning to the normal autosend mode is done using the following command:

```
CEILO > set message transmission periodic
```

The polling string format is as follows:

<Enq> CL*Id*No ↵

Where

- Enq = Character ENQUIRE = ASCII 05H = control-E.
- CL = Fixed ceilometer identifier; CL for CL31 messages, CT for CT25K and CT25KAM messages.
- Id* = Identification character, 7-bit printable ASCII character.
- No* = Optional message identifier; 1 or 6 for CT messages and 1, 2 or S for CL messages. The CL identifier 1 returns the default option for data message No. 1. To return a particular subclass message, use one of the following identifiers: 11, 12, 13, 14, or 15. Data message No. 2 is requested similarly: 21, 22, 23, 24, or 25. . The identifier S returns the Status message.
- ↵ = ENTER (Carriage Return) + Line Feed.

The following are examples of the polling command:

```
<Enq> CL112<Enter>    Message 1, subclass 2 from ceilometer No.1
<Enq> CT11<Enter>     CT25K Message 1 from ceilometer No.1
```



If the id character in a polling string is replaced with a blank space, all ceilometers on the line will respond. Accordingly, if No is a blank space, CL31 sends the default message. In RS-485 mode id is always needed, the blank space is ignored.

LD40 message is polled by sending an LD40 Command Telegram. See Table 20 below for a description of the command telegram frame of a polling request.

Table 20 Command Telegram Description 'Polling Request'

Byte	Example	Description
0	<STX>	02 HEX (Start of text)
1	H	Command telegram header
2	0	Command telegram header
3	C	Command telegram header
4	!	Command telegram header
5	X	Instrument type --> Ceilometer
6	1	Sensor Id number (0 to 9..ABC..MIN). In this case --> 1
7-17	P-----	Command indicator --> P (polling), byte 8-17 not used and filled with '-'
18-19	83	Checksum (Hex-coded two's complement of the sum of bytes from 0 to 20, excluding bytes 18 and 19).
20	<EOT>	04 Hex (End of transmission)

This page intentionally left blank.

CHAPTER 6

MAINTENANCE

This chapter provides information on CL31 maintenance.

Periodic Maintenance

Periodic maintenance is normally limited to window cleaning. In addition, check warnings and alarms regularly with the maintenance terminal, another terminal, or PC with a serial connection. For more information, see CL31 Status Message on page 75. The only mechanically moving part, the window blower, is automatically checked once an hour. Malfunction is reported in the data and status messages.

Alarms and Warnings

Check the data message for alarms and warnings on a regular basis. The second character in line two contains warning and alarm information indicating the present device status as follows:

0	Self-check OK
W	At least one warning active, no alarms
A	At least one alarm active

In case there is an active alarm or warning, more information is given at the end of the second line as a binary code indicating the cause. The status message gives detailed information about the failure. See section Data Messages on page 67.

For instructions on repair and service, see Chapter 7, Troubleshooting, on page 101 and Repair on page 109.

Cleaning

Data messages include a warning that informs when the window is contaminated. After the system has detected contamination on the window, it starts the blower, which is designed to remove light contaminants and dry off rain drops. If the blower cannot remove the contamination, CL31 issues a **Window Contaminated** warning indicating that the window must be manually cleaned.

To clean the window:

1. Make sure the enclosure is closed. Flush the window with clean water to remove coarse grains. Do not use pressure cleaners.
2. Clean the window with a soft, lint-free cloth moistened with a mild detergent. Be careful not to scratch the window surface.

While cleaning the window, you can also check the operation of the window blower. The blower starts when you block the laser beam with the cleaning cloth for approximately 5 seconds. This verifies that the blower is functional. If there are no low clouds, precipitation, or fog present, the blower should stop after the window is cleaned. In case of malfunction, you need to replace the window blower.

Window Contamination Measurement Calibration

After 5 years of operation, calibrate the window contamination measurement.

If the CL31 system starts issuing **Window Contamination** warnings frequently without a real reason, this may indicate that the window is worn out or the window contamination measurement has drifted. In that case, the window contamination measurement can be calibrated to ensure proper functioning.

To calibrate window contamination measurement:

1. Check the sky condition. In case of fog, smoke, precipitation, or otherwise unclear sky, use the termination hood (CLTERMHOOD) in calibration.
2. Make sure that the window is cleaned.
3. Open the command line and enter the Advanced level by giving the **advanced** command.
4. Give the **set factory win_clean** command.

The calibration is carried out automatically.



If the window is visibly worn out, replace it.

Checking Door Gasket

The measurement unit door utilizes an electrically conductive gasket to suppress electromagnetic radiation. When the door is opened, check that the gasket and the opposite contact surfaces are clean. If necessary, use a wet cloth for cleaning.

Checking Battery

Check the battery condition annually. If there are any signs of aging, such as a bulging battery case, white powder, or residue near the battery vent, leaking electrolyte, or corroded terminals, replace the battery. Lead acid batteries may age in 3 to 5 years and result in a rupture and loss of electrolyte.



When disposing of old batteries, follow local environmental regulations.



In freezing temperatures there is a danger of battery rupture if the battery is completely discharged. Do not store empty batteries in freezing temperatures. Replace the battery if signs of mechanical rupture are observed.

Storage

If CL31 is stored unpacked for extended periods of time in an unconditioned area, keep caps on all external connectors. Keep the measurement unit door closed and also keep a dust cover on the window during long periods of storage.

Save the container for future transport use. For transportation, the equipment must be placed and padded into the container in the same way as initially received.

This page intentionally left blank.

CHAPTER 7

TROUBLESHOOTING

This chapter describes common problems, their probable causes and remedies, and contact information for technical support.

Troubleshooting Procedure

The goal of troubleshooting is to locate the cause for the potential problem. Failure situations are usually caused by dirt in optics or unclarity of the optical path. Also external conditions or the following replaceable subassemblies may be the source of problems:

- CLE321 Ceilometer Engine Board
- CLT321 Ceilometer Transmitter
- CLR321 Ceilometer Receiver
- CLM311 Laser Monitor Board
- CLP321 AC Power
- CLB311-115/230 Blower
- CLH311-115/230 Heater
- 226296 Coaxial cable
- No-break Battery

If damage is suspected in a subassembly or a board, replace it with a spare part and send the defective part to Vaisala for repair/replacement.



Replacements must only be performed by qualified maintenance personnel, and they must be done according to the instructions in Repair, on page 109. As a principle, customer made repairs are restricted to the replacement of subassemblies.

Accessing Diagnostic Information

During normal operation, CL31 continuously monitors its internal status and regularly checks the blower and the heater. CL31 automatically analyzes the diagnostic test results and reports potential failures with every data message. For more information, see CT25K Data Messages on page 83.

CL31 automatically identifies the potentially faulty subassemblies. If this does not help, see Table 21 on page 105, Table 22 on page 106 and Table 23 on page 107 for probable causes for warnings, alarms, and other typical faults. You can also use the tables to rule out any problems related to cable connections or the clarity of the window or optical path.

Equipment for Troubleshooting

To establish a service connection to CL31 you need to have a maintenance terminal which can be a palmtop computer with an RS-232 Interface or a PC with serial interface, Maintenance cable QMZ101, and any terminal program. You can use the CL-VIEW software for this purpose. If you perform the operation check indoors, you need to have an Optical Termination Hood (CLTERMHOOD) which absorbs the laser light that would otherwise reflect from the ceiling and possibly saturate the receiver.



The maintenance connection can also be established through the data line if, for example, the ceilometer is out of use. This stops the data flow for as long as the command line is open.

Troubleshooting Instructions

To check the normal operation of the CL31:

1. Clean the window carefully with a soft, lint-free cloth moistened with a mild detergent. Be careful not to scratch the window surface.
2. If you are indoors, put the optical termination hood (CLTERMHOOD) on the ceilometer window. To the ceilometer this represents a clear, nighttime sky.
3. Connect the maintenance terminal to the maintenance port at the bottom of CL31. Turn on both the CL31 and the maintenance terminal. If you are using the palmtop or the CL-VIEW program for the first time, make the necessary installations according to the manuals of these products.
4. Verify that the ceilometer starts operating properly. A quick status check can be made by looking at the LEDs on the CLE321 board

(see Figure 27 on page 119). After the initialization routines, the **Laser on** LED should start blinking at 2-second intervals. If all the key modules are ok, also all the six diagnostic LEDs should light up.

5. A blower check is done during the first five minutes, during which the blower is running. The automatic check also verifies the functioning of the blower heater. The result of this check is available five minutes after starting the unit and it is indicated by the **CLB ok** LED. It is also displayed in the status message.
6. To get the failure status message, type the **open** command and press ENTER on the maintenance terminal (PC) keyboard. A CEILO > prompt should appear. Give the **get failure status** command and press ENTER.

An example of the response is as follows:

```
Alarms
Tmit Shutoff   OK      Transmitter   ALRM
Receiver       OK      Voltages      OK
Ext Memory     OK      Light Pth Obs OK
Rec Saturat    OK      Coaxial Cable OK
Engine         OK

Warnings
Window Contam OK      Battery Low   OK
Transm Expire OK      Humid High    OK
Blower         OK      Humid Sensor  OK
Int Heater     OK      High Rad      OK
Engine         OK      Battery       OK
Laser Monitor  OK      Receiver      OK
Tilt Angle     OK

System Status:   FAIL
Suspect Module:  CLT
```

The two last lines in the status message will indicate if there are warnings or alarms present. The **Suspect module** line indicates the sub unit that is suspected to be faulty. In this example, it is the Ceilometer Transmitter CLT321.

7. Wait until the 5-minute blower check is over and check the result from the status message. After this, place a piece of white paper on the ceilometer window. The blower should start within one minute. Remove the paper. The blower should stop within eight minutes.

8. If there are clouds present, compare the ceilometer measurement with a qualified weather observer's height approximation.
9. In case there are no clouds present and if the site is suitable, do a hard target test. Turn the measurement unit 90 degrees and aim it on a fixed target (such as a wall or a forest front).

The minimum distance to a hard target should be 300 meters (1 000 ft). The backscatter signal from a hard target is very strong compared to the signal from a cloud. The receiver may saturate if the distance is too short.



CAUTION!

When tilting the unit, make sure that nobody is watching the beam with binoculars or other magnifying optics.

Disable the automatic angle correction with the following commands:

```
CEILO > SET MESSAGE ANGLE_COR OFF
```

```
CEILO > CLOSE
```

Compare the distance reading of the ceilometer to a reference measurement.

Warning and Alarm Messages

This section describes different warning and alarm messages.

Table 21 CL31 Status, Warnings

Status Message Info	Reason	Instructions
Window contamination warning (appears from time to time and lasts < 5 min)	Usually drizzle drops on the window.	The blower will clean the window. If clouds are detected, the height information is correct. If no clouds are detected, it is possible that high clouds are missed.
Window contamination warning (continuous)	Bird droppings, leaves, dust etc. have contaminated the window.	Clean the window.
Battery low warning	The unit has been powered too long using the backup battery.	Connect the line voltage or replace the battery.
	Recharging of the battery has failed.	If the battery is old, replace it. If the battery is OK, check the operation of Ceilometer Engine Board CLE321.
Transmitter expires warning	Laser diode is too old.	Replace Transmitter CLT321. The measurement data is valid, but it is possible that some clouds are missed.
High humidity warning (option)	Relative humidity > 85 %. Water has been condensed inside the ceilometer. Leakage in the enclosure or leakage in the door.	Take the ceilometer inside, open the maintenance door and let it dry in a warm air conditioned place. Condensed water on optical surface may disturb the measurement. There is a danger of short circuits.
Blower failure warning	Blower cable is not connected.	Check that the blower cable is connected.
	Window blower circuit breaker is not ON.	Check that the window blower circuit breaker is ON.
	Line voltage level is not correct.	Check that the line voltage is present and correct.
	Blower is stuck.	Check if visible obstacles disable blower operation.
	Blower is damaged.	Replace the blower.
Humidity sensor failure warning (option)	Humidity sensor is not connected.	Connect the humidity sensor or disable the option in the software.
	Humidity sensor is damaged.	Contact technical support and send the ceilometer CL31 to Service Center for the humidity sensor to be replaced.
Heater fault warning	Window blower circuit breaker is not ON.	Check that the window blower circuit breaker is ON.
	Line voltage level is not correct.	Check that the line voltage is present and correct.
	Heater is damaged.	Replace the heater.
High background radiance warning	Direct sunlight.	In case there are no alarms, the measurements are ok. If there is an alarm, the measurements are invalid.
Ceilometer Engine Board failure warning	Non-critical fault in Ceilometer Engine Board CLE321.	Replace Ceilometer Engine Board CLE321.
Battery failure warning	Battery is dead.	Replace the battery.

Status Message Info	Reason	Instructions
Laser monitor failure warning	Laser power monitor board CLM311 has failed.	Replace CLM311.
	Laser power measurement on Ceilometer Engine board CLE321 has failed.	Replace CLE321.
Receiver warning	A non-critical CLR321 Receiver failure.	Replace CLR321.
Tilt angle > 45° warning	The unit is not correctly installed or the tilt angle is larger than 45°.	Check the installation. The height measurement accuracy is lost with tilt angles greater than 45°.

Table 22 CL31 Status, Alarms

Problem	Reason	Instructions
Transmitter shut-off alarm (Laser temperature > 85 °C)	Direct sunlight has heated the laser.	Wait for the sun to exit the field-of-view. CL31 returns to normal operation.
	Environment temperature is too high.	Check if there is a specific reason for the high temperature.
Transmitter failure alarm	Laser is worn out or damaged.	Replace Laser Transmitter CLT321.
	Laser does not get electrical power.	Check from the status message that the line Voltages is marked OK .
Receiver failure alarm	Receiver CLR321 is damaged.	Replace CLR321.
	Loose cable connection.	Check that the cables from Receiver CLR321 and Ceilometer Optics CLO321 are undamaged and correctly connected.
	Receiver test not operating.	Check that the Optics unit CLO321 is not misplaced or damaged. If the CLO321 unit is damaged or missing, contact Vaisala for repair and replacement, since the CLO321 unit is not field replaceable.
Voltage failure alarm	Ceilometer Engine Board CLE321 is damaged.	Replace CLE321.
Memory error alarm	A failure in the CLE321 memory.	Replace CLE321.
Light path obstruction alarm	Window is badly contaminated or severely scratched.	Clean the window or in case of damage, replace CLW311.
	Something blocks the laser beam.	Check the clarity of the optical path.
Receiver saturation alarm	Direct sunlight.	Wait for the sun to exit the field-of-view. CL31 returns to normal operation.
	Something is partially blocking the laser beam.	Check the clarity of the optical path.

Table 23 CL31 Status, Miscellaneous Problems

Problem	Reason	Instructions
CL31 does not start, no LEDs are lit	Power is not connected.	Check that both the main and the battery switches are in the ON position. Check the presence and correctness of the line voltage, and make sure that the battery is OK.
	Loose cable connection.	Check the cable connections.
Laser on LED is not blinking but the Status LED is lit.	Operation mode is standby.	Connect the maintenance terminal and check if the operation mode is normal.
	CLE321 is damaged.	Replace CLE321.
Data message is missing.	Dialogue is not operating.	Check the cable connections. Open the terminal.
	Wrong communication parameters.	Check the communication parameters (number of bits, parity, etc.).
	Wrong data port.	Open the terminal program and give open command and then get params message command. Check that the PORT is set to DATA.
	Operation mode is standby.	Open the terminal program and first give the open command and then the status command. Check that the OPERATION MODE is NORMAL.
Cloud detection is missing.	Equipment failure.	Open the terminal program and give open command and then get failure status command. Check the alarms and warnings. If there are no alarms or warnings in the data message, contact Vaisala.
The capability to detect high clouds is reduced.	Low receiver gain (no fog or snow).	Check the automatic receiver gain setting in the status message. If it is low, check that the window is clean. Check that the optical path is clear. Visually check that the lens is clean.
	Extensive amount of dirt or water droplets on the window and a failure in the diagnostics.	Check the window clarity. Check the blower operation by giving the service self_check command and check that the blower works.

Technical Support

For technical questions, contact the Vaisala technical support by e-mail at helpdesk@vaisala.com. Provide at least the following supporting information:

- Name and model of the product in question
- Serial number of the product
- Name and location of the installation site
- Name and contact information of a technically competent person who can provide further information on the problem.

For Vaisala Service Center contact information, see www.vaisala.com/servicecenters.

CHAPTER 8

REPAIR

This chapter provides information on how to remove and replace different parts of the product.

Table 24 Available Spare Parts

Spare Part Code	Common Name
226116	No-break Battery
CLB311-115SP	Window Blower 115 VAC
CLB311-230SP	Window Blower 230 VAC
CLE321SP	Engine board
CLH311-115SP	Inside Heater 115 VAC
CLH311-230SP	Inside Heater 230 VAC
CLHUMITTERSP	Humitter
CLM311SP	Laser Monitor Board
CLP321SP	AC Power
CLR321SP	Ceilometer Receiver
CLT321SP	Ceilometer transmitter
CLTERMHOODSP	Optical Termination Hood
CLW311SP	Window Assembly
CT35022SP	Shock Absorber Kit
CT35324SP	Power cable (115 V)
CT3838SP	Data Cable
CT3839SP	Power cable (230 V)
DXL421SP-CL31	Modem Module
226296SP	Coaxial Cable
TERMBOX-1200SP	Termination Box with overvoltage protection
CLTERMBOXSP	Termination Box
QMZ101SP	Terminal Cable for MAWS
CL31USBCABLESP	CL31USB Cable
CLRADIOKITSP	Radio Modem Kit
CL31BIRDKITSP	Bird deterrent
CL31TOPCOVERKIT	Top Cover Kit

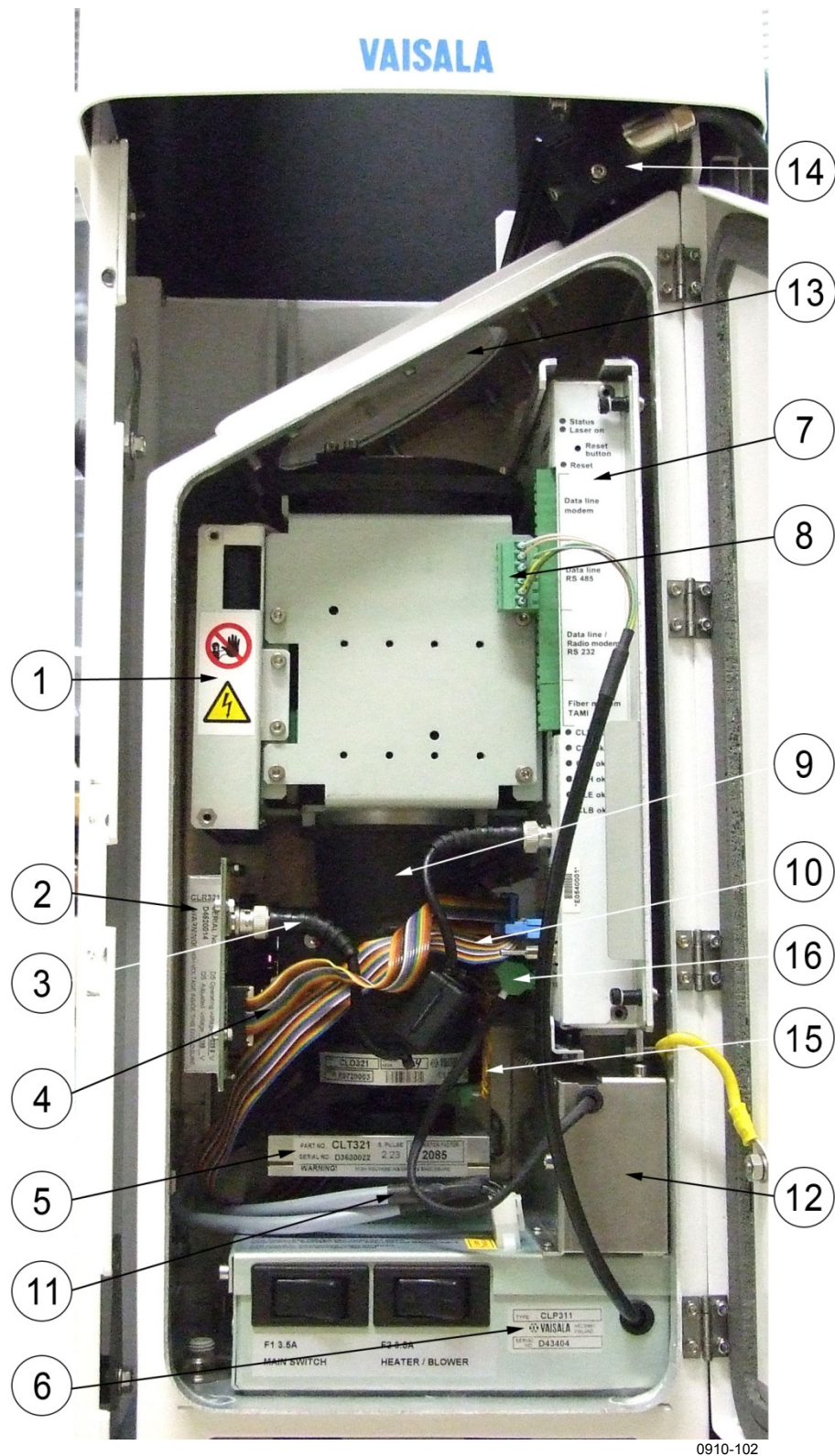

Figure 22 CL31 Maintenance Parts

0910-102

- 1 = Internal heater CLH311
- 2 = Ceilometer Receiver CLR321
- 3 = Coaxial cable 226296
- 4 = Receiver ribbon cable
- 5 = Ceilometer transmitter CLT321
- 6 = Ceilometer AC power CLP321
- 7 = Ceilometer engine board CLE321
- 8 = Data line connector
- 9 = Optics unit CLO321
- 10 = Transmitter ribbon cable
- 11 = AC power cables
- 12 = No-break battery
- 13 = Window CLW311
- 14 = Window Blower CLB311
- 15 = Laser Monitor Board CLM311
- 16 = Battery cable

Replacing Window CLW311

See number 13 in Figure 22 on page 110.



Vaisala recommends that you replace Ceilometer Window CLW311 indoors to prevent water and other contamination from getting into the measurement unit.

You need a 2.5 mm Allen-key and a screwdriver.

To replace CLW31:

1. Open the measurement unit door. Then switch the power off with all three switches (F1, F2, and Battery). For the location of the switches, see Figure 15 on page 40 and Figure 16 on page 41.



WARNING!

Disconnect the power cable from connector J2 before continuing.

2. Close the door and remove the measurement unit. To do this, loosen the three attachment screws (marked A in Figure 7 on page 28), disconnect the blower cable from connector J1 (see Figure 12 on page 35) and pull out the unit.
3. Loosen the 12 screws on the frame of the window and remove the window by lifting it out with the screws attached. Also remove any pieces of the old gasket.

4. Use some solvent to clean the surface of the measurement unit before attaching the new window. Additionally, check that the gasket on the window is undamaged and in place.



Avoid touching the new window with your bare hands as it may get scratched. Avoid also touching the clean window surface as it may get contaminated.

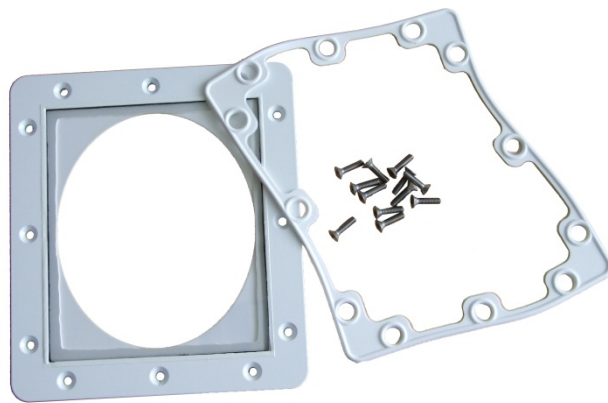

0910-113

Figure 23 Window CLW311

5. Place the window on the measurement unit and attach the 12 screws with your fingers to prevent the window from sliding off its place.
6. Tighten the screws in a crosswise order to allow the window gasket to tighten evenly. For example, you can first tighten the screw on top of the window frame, then the one on the bottom, then the one on the left, and the one on the right. Tighten the remaining eight screws in a clockwise order, in such a way that you first tighten one screw and then the one opposite to this, then the one next to the first screw and so forth. After tightening these eight screws, retighten the first four screws.



Remember to use a thread-locking compound to the window screws before final tightening.

7. After attaching the window, clean it properly. See section *Cleaning* on page 97.

8. Place the measurement unit inside the shield, reconnect the blower cable to connector J1, and tighten the three attachment screws (marked A in Figure 7 on page 28).
9. Connect the power cable to connector J2.
10. Switch the power on with all three switches. Wait until the **Laser on** LED starts blinking at 2-second intervals. Make sure that all six diagnostic LEDs are lit. Refer to Figure 27 on page 119.

The ceilometer unit should now return to normal operation. Verify that the unit is working properly and that there are no failures with the system. If failures exist, separate troubleshooting may be necessary.

Replacing Ceilometer Laser Transmitter CLT321

Refer to number 5 in Figure 22 on page 110.



WARNING!

Ceilometer Transmitter CLT321 emits invisible laser radiation, which is harmful to the eye if viewed at a short distance. Never remove the Ceilometer Transmitter from its normal position without first switching off both the line and the battery power and detaching the transmitter ribbon cable from the Ceilometer Engine Board CLE321.



CAUTION!

Servicing the equipment must only be performed by qualified maintenance personnel.



0910-112

Figure 24 Laser Transmitter CLT321

The transmitter should be replaced if the ceilometer unit has been generating warnings and alarms, and a malfunction with the operation of the transmitter has been detected.

To replace Ceilometer Laser Transmitter CLT321, you need a 2.5 mm Allen-key.

To replace CLT321:

1. Open the measurement unit door and confirm that there is an active transmitter failure. In case of a transmitter failure, the **CLT ok** LED turns off. Refer to Figure 27 on page 119.
2. Switch off the power with all three switches (F1, F2, and Battery). For the location of the switches, see Figure 15 on page 40 and Figure 16 on page 41.



WARNING!

Disconnect the power cable from connector J2 before continuing.

3. Detach the transmitter ribbon cable (refer to number 10 in Figure 22 on page 110) from Ceilometer Engine Board CLE321.
4. To detach the transmitter, loosen the transmitter ring by turning it to the right. If necessary, you can use a 2.5-mm Allen key as a lever. Remove the transmitter from the unit.
5. Place the new transmitter to its place and tighten the transmitter ring in such a way that the labels of the transmitter face the measurement unit door.
6. Connect the transmitter ribbon cable to the CLE321 board.
7. Connect the power cable to connector J2.
8. Switch on the power with all three switches. Wait until the **Laser on** LED starts blinking at 2-second intervals. Ensure that all six diagnostic LEDs are lit. Refer to Figure 27.

The ceilometer unit should now return to normal operation. Verify that the unit is working properly and that there are no other failures with the system. If other failures exist, separate troubleshooting may be necessary.

To avoid interference, make sure that you keep the RX flat cable and the TX flat cable apart.

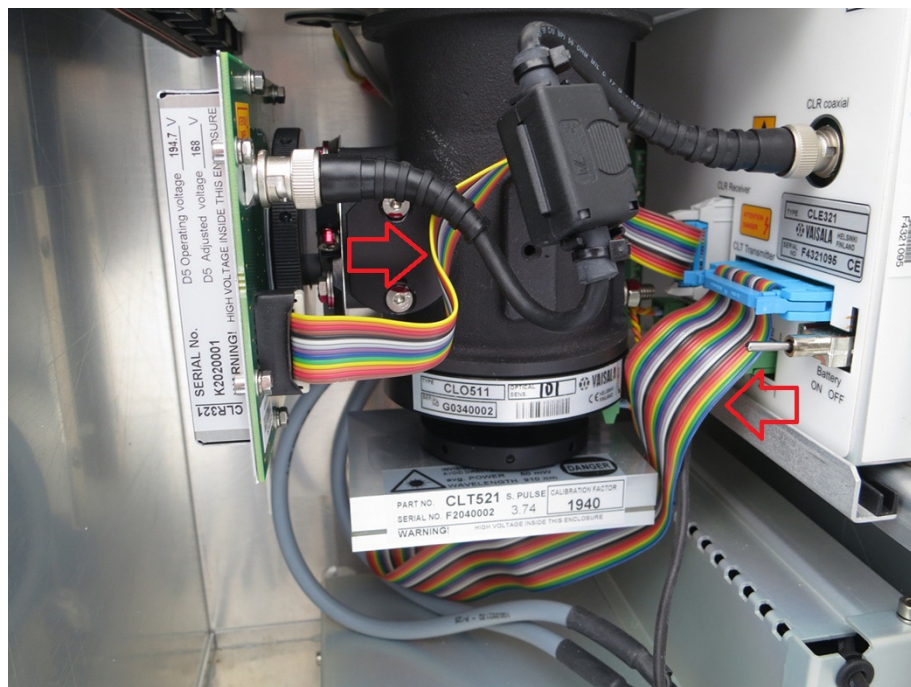

1506-107

Figure 25 Routing RX and TX Flat Cables

Replacing Ceilometer Receiver CLR321

Refer to number 2 in Figure 22 on page 110.



CAUTION!

Servicing the equipment must only be performed by qualified maintenance personnel.

The receiver should be replaced if the ceilometer unit has been generating warnings and alarms, and a malfunction in the receiver operation has been detected.

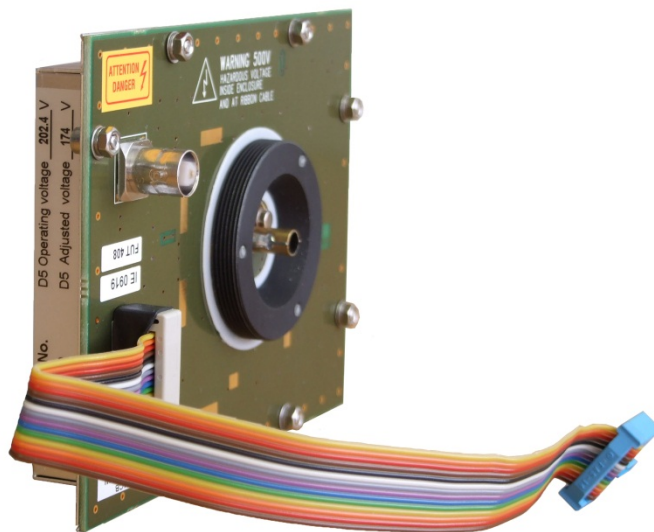

0910-111

Figure 26 Receiver CLR321

To replace Ceilometer Receiver CLR321, you will need a 2.5 mm Allen-key. Then proceed as follows:

1. Open the measurement unit door and confirm that there is an active receiver failure. In case of a receiver failure, the **CLR ok** LED turns off. Refer to Figure 27 on page 119.
2. Switch off the power with all three switches (F1, F2, and Battery). For the location of the switches, see Figure 15 on page 40 and Figure 16 on page 41.



WARNING!

Disconnect the power cable from connector J2 before continuing.

3. Detach the coaxial cable (refer to number 3 in Figure 22 on page 110) from the receiver. Then detach the receiver ribbon cable (refer to number 4 in Figure 22) from Ceilometer Engine Board CLE321.
4. To detach the receiver, loosen the receiver ring by turning it downwards. If necessary, you can use a 2.5-mm Allen key as a lever. Remove the receiver from the unit.
5. Place the new receiver to its place and tighten the receiver ring in such a way that the labels of the receiver face the left wall of the enclosure.
6. Connect the receiver ribbon cable to the CLE321 board and the coaxial cable to the receiver.
7. Connect the power cable to connector J2.
8. Switch on the power with all three switches. Wait until the **Laser on** LED starts blinking at 2-second intervals. Ensure that all six diagnostic LEDs light up after the self-test. Refer to Figure 27 on page 119.

The ceilometer unit should now return to normal operation. Verify that the unit is working properly and that there are no other failures with the system. If other failures exist, separate troubleshooting may be necessary.

To avoid interference, make sure that you keep the RX flat cable and the TX flat cable apart, as shown in Figure 25 on page 116.

Replacing Ceilometer Engine Board CLE321

Refer to number 7 in Figure 22 on page 110.



0910-104

Figure 27 Ceilometer Engine Board CLE321



CAUTION!

Servicing the equipment must only be performed by qualified maintenance personnel.

Ceilometer Engine Board CLE321 should be replaced if the ceilometer unit has been generating warnings and alarms, and a malfunction with the operation of the CLE321 board has been detected.

To replace Ceilometer Engine Board CLE321, you need a screwdriver.

To replace CLE321:

1. Open the measurement unit door and confirm that there is an active CLE321 board failure. In case of a CLE321 board failure, the **CLE ok** LED turns off. Refer to Figure 27 on page 119.
2. Switch off the power with all three switches (F1, F2, and Battery). For the location of the switches, see Figure 15 on page 40 and Figure 16 on page 41.

**WARNING!**

Disconnect the power cable from connector J2 before continuing.

3. Detach the transmitter ribbon cable, the receiver ribbon cable, and the coaxial cable from Ceilometer Engine Board CLE321. (Refer to numbers 10, 4, and 3 in Figure 22 on page 110, respectively.)
4. Memorize the position of the data line connector (RS-232/RS-485/Modem; refer to number 8 in Figure 22) in front of the CLE321 board and detach it. Refer to Figure 27.
5. Loosen the hand screws to release the CLE321 board from the frame. Gently pull the CLE321 board halfway out of the measurement unit and detach the battery cable (refer to number 16 in Figure 22) and the CLM311 cable (refer to number 15 in Figure 22). Then remove the entire CLE321 board. Refer to Figure 27.
6. Place the new CLE321 board onto the frame in such a way that you can reconnect the battery cable and the CLM311 cable.
7. Reattach the receiver ribbon cable, the transmitter ribbon cable, and the coaxial cable when the board is pushed halfway in.
8. Push the CLE321 board in such a way that it connects to the back plane connector. Tighten the hand screws to lock the board position.
9. Connect the data line connector to the same position as it was connected to on the previous board.
10. Connect the power cable to connector J2.
11. Switch on the power with all three switches. Wait until the **Laser on** LED starts blinking at 2-second intervals. Make sure that all six diagnostic LEDs light up after the set-test. Refer to Figure 27.

The ceilometer unit should now return to normal operation. Verify that the unit is working properly and that there are no other failures with the system. If other failures exist, separate troubleshooting may be necessary.

Replacing No-break Battery

Refer to number 12 in Figure 22 on page 110.



CAUTION!

Servicing the equipment must only be performed by qualified maintenance personnel.

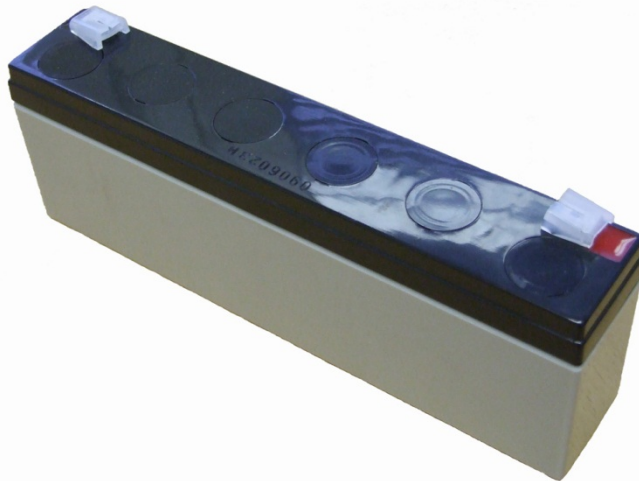

0910-110

Figure 28 No-break Battery

The no-break battery should be replaced when it is damaged or, for whatever reason, can no longer be recharged.

You need a crosshead screwdriver and a 3 mm Allen-key.

To replace the battery:

1. Open the measurement unit door and switch off the power with all three switches (F1, F2, and Battery). For the location of the switches, see Figure 15 on page 40 and Figure 16 on page 41.



WARNING!

Disconnect the power cable from connector J2 before continuing.

2. Disconnect the battery cable (refer to number 16 in Figure 22 on page 110) from the CLE321 board.

3. Remove the two screws locking the lid of the battery cage. One of the screws is located on top of the battery cage, the other is on the left side near the top of the cage.
4. Open the lid of the battery cage and slide out the battery. Disconnect the battery cable.
5. Connect the battery cable to the new battery, connecting the red end to the positive (+) pin and the black end to the negative (-) pin.
6. Slide the new battery into the battery cage and close the lid. Tighten the two screws back to their places.
7. Reconnect the battery cable to the CLE321 board.
8. Connect the power cable to connector J2.
9. Switch on the power with all three switches. Wait until the **Laser on** LED starts blinking at 2-second intervals. Make sure that all six diagnostic LEDs light up after the self-test. Refer to Figure 27 on page 119.

The ceilometer unit should now return to normal operation. Verify that the unit is working properly and that there are no other failures with the system. If other failures exist, separate troubleshooting may be necessary.

Replacing AC Power CLP321

Refer to number 6 in Figure 22 on page 110.



CAUTION!

Servicing the equipment must only be performed by qualified maintenance personnel.

Replace AC Power CLP321 if the ceilometer unit has been generating warnings and alarms, and a malfunction with the operation of the power unit is detected.



0910-106

Figure 29 AC Power CLP321

To replace the AC power, you need a 3 mm Allen-key. The Optics unit and battery cage have to be removed before replacing CLP321.

To replace CLP321:

1. Open the measurement unit door and confirm that there is an active AC power unit failure. In case of an AC power unit failure, the **CLP ok** LED turns off. Refer to Figure 27 on page 119.
2. Switch off the power with all three switches (F1, F2, and battery). For the location of the switches, see Figure 15 on page 40 and Figure 16 on page 41.

**WARNING!**

Disconnect the power cable from connector J2 before continuing.

3. Disconnect the battery, transmitter, receiver, laser monitor board, and data cables (refer to numbers 3, 4, 8, 10 and 16 in Figure 22 on page 110) from the CLE321 board.
4. To remove the Optics Unit (refer to number 9 in Figure 22), first remove the holder plate by loosening the four Allen screws on its front cover.
5. Detach the internal heater connector and holding the cable aside, carefully pull out the Optics Unit upper end first.



Do not touch the lens of the Optics Unit.

6. Detach the CLM311 twisted pair cable (refer to number 15 in Figure 22) from the CLE321 board.
7. Remove the battery. Refer to steps 3 to 5 in section Replacing No-break Battery on page 121.
8. Remove the battery cage by removing the three screws holding it in its place. One of the screws is located inside the battery cage, the other two are on the left side near the bottom of the cage.
9. Detach the data line cable from the connector J3.
10. Remove the six CLP321 attachment screws from the bottom of the ceilometer measurement unit. Also disconnect the AC power cable (refer to number 11 in Figure 22). Lift the AC power unit from the ceilometer measurement unit.
11. Put the new AC power unit in place of the old one and connect the AC power cable. Tighten the six attachment screws back to their places.
12. Reattach the data line connector.
13. Put the battery cage back to its place and tighten the three screws.
14. Attach the CLM311 twisted pair cable to the CLE321 board.
15. Slide the Optics Unit to its place with the bottom end first. Make sure that no cables get stuck between the optics tube and other ceilometer components.
16. Snap the internal heater connector to its place.
17. Place all heater cables behind the holder and tighten the four holder screws.

18. Reconnect the battery, transmitter, receiver, laser monitor board, and data cables to the CLE321 board.
19. Insert and reconnect the battery as you removed it. Refer to steps 6 to 8 in section Replacing No-break Battery on page 121.
20. Connect the power cable to connector J2.
21. Switch on the power with all three switches. Wait until the **Laser on** LED starts blinking at 2-second intervals. Ensure that all six diagnostic LEDs light up after the self-test. Refer to Figure 27 on page 119.

The ceilometer unit should now return to normal operation. Verify that the unit is working properly and that there are no other failures with the system. If other failures exist, separate troubleshooting may be necessary.

Replacing Window Blower CLB311

Refer to number 14 in Figure 22 on page 110.



CAUTION!

Servicing the equipment must only be performed by qualified maintenance personnel.



CAUTION!

Be careful not to contaminate or scratch the window.

Replace the window blower if the ceilometer unit has been generating warnings and alarms, and a malfunction with the operation of the blower has been detected.

To replace Ceilometer Window Blower CLB311, you need a 5 mm Allen-key.

To replace CLB311:

1. Open the measurement unit door and confirm that there is an active window blower failure. In case of a window blower failure, the **CLB ok** LED turns off. Refer to Figure 27 on page 119.
2. Switch off the power with all three switches (F1, F2, and Battery). For the location of the switches, see Figure 15 on page 40 and Figure 16 on page 41.



WARNING!

Disconnect the power cable from connector J2 before continuing.



0910-105

Figure 30 Window Blower CLB311-115 / CLB311-230

3. As the blower is attached to the shield of the ceilometer, you first have to remove the measurement unit from the shield to get to the blower. To remove the measurement unit, loosen the three attachment screws (marked A in Figure 7 on page 28), disconnect the blower cable from connector J1 (see Figure 12 on page 35) and pull out the unit.
4. Use an Allen key to loosen the two screws on the side of the window blower, then pull out the blower.
5. Use the same Allen screws to attach the new window blower.
6. Reattach the measurement unit by placing it inside the shield, reconnecting the blower cable to connector J1, and tightening the three attachment screws.
7. Connect the power cable to connector J2.
8. Switch on the power with all three switches. Wait for 5 minutes after the start-up until self-check is completed. Ensure that all six diagnostic LEDs are lit. Refer to Figure 27.

The ceilometer unit should now return to normal operation. Verify that the unit is working properly and that there are no other failures with the system. If other failures exist, separate troubleshooting may be necessary.

Replacing Internal Heater CLH311

Refer to number 1 in Figure 22 on page 110.



CAUTION!

Servicing the equipment must only be performed by qualified maintenance personnel.



Internal Heater CLH311 is recommended to be replaced indoors.

Replace the internal heater if the ceilometer unit generates warnings and alarms, and a malfunction with the operation of the heater has been detected.

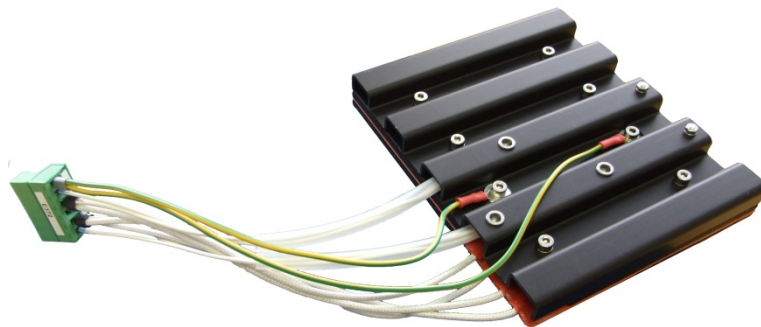

0910-107

Figure 31 Internal Heater CLH311-115 / CLH311-230

To replace Internal Heater CLH311, you need a 3 mm Allen-key. The Optics unit has to be removed before replacing CLH311.

To replace the heater:

1. Open the measurement unit door and confirm that there is an active internal heater failure. In case of an internal heater failure, the **CLH ok** LED will be off. Refer to Figure 27 on page 119.
2. Switch off the power with all three switches (F1, F2, and battery). For the location of the switches, see Figure 15 on page 40 and Figure 16 on page 41.

**WARNING!**

Disconnect the power cable from connector J2 before continuing.

3. Close the enclosure door and remove the measurement unit. To do this, loosen the three attachment screws (marked A in Figure 7 on page 28, disconnect the blower cable from connector J1 (see Figure 12 on page 35) and pull out the unit.
4. Remove the metal plate protecting the heater by loosening its two screws.
5. Disconnect the battery, transmitter, receiver, and data cables (refer to numbers 3, 4, 8, 10 and 16 in Figure 22 on page 110) from the CLE321 board.
6. To remove the Optics Unit (refer to number 9 in Figure 22), first remove the holder plate by loosening the four Allen screws on its front cover.
7. Detach the internal heater connector and holding the cable aside, carefully pull out the Optics Unit upper end first.



Do not touch the lens of the Optics Unit.

8. Detach the CLM311 twisted pair cable (refer to number 15 in Figure 22) from the CLE321 board.
9. To remove the internal heater, use an Allen key or a short screwdriver and loosen the three screws attaching the heater to the left wall of the measurement unit enclosure. Then slide out the internal heater.
10. Slide the new internal heater to its place and hold it there while tightening the three screws.
11. Attach the CLM311 twisted pair cable to the CLE321 board.

12. Slide the optics tube to its place with the bottom end first. Make sure no cables get stuck between the optics tube and other ceilometer components.
13. Snap the internal heater connector to its place.
14. Place all heater cables behind the holder and tighten the four holder screws.
15. Reconnect the battery, transmitter, receiver, and data cables to the CLE321 board.
16. Reattach the metal plate protecting the internal heater.
17. Insert the measurement unit inside the shield, reconnect the blower cable to connector J1, and tighten the three attachment screws.
18. Connect the power cable to connector J2.
19. Switch on the power with all three switches. Wait until the **Laser on** LED starts blinking at 2-second intervals. Ensure that all six diagnostic LEDs are lit. Refer to Figure 27 on page 119.

The ceilometer unit should now return to normal operation. Verify that the unit is working properly and that there are no other failures with the system. If other failures exist, separate troubleshooting may be necessary.

Replacing Laser Monitor Board CLM311

See number 15 in Figure 22 on page 110.



CAUTION!

Servicing the equipment must only be performed by qualified maintenance personnel.

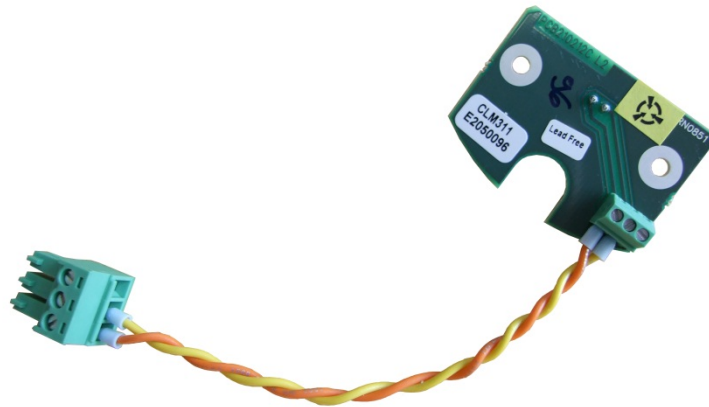

0910-109

Figure 32 Laser Monitor Board CLM311

To replace Laser Monitor Board CLM311, you will need a 2.5 mm Allen-key and a calculator. The Optics unit and transmitter module have to be removed before replacing CLM311.

To replace CLM311:

1. Open the measurement unit door and switch off the power with all three switches (F1, F2, and battery). For the location of the switches, see Figure 15 on page 40 and Figure 16 on page 41.

**WARNING!**

Disconnect the power cable from connector J2 before continuing.

2. Disconnect the battery, transmitter, receiver, and data cables (refer to numbers 3, 4, 8, 10 and 16 in Figure 22 on page 110) from the CLE321 board.
3. To remove the Optics Unit (refer to number 9 in Figure 22), first remove the holder plate by loosening the four Allen screws on its front cover.
4. Detach the internal heater connector and holding the cable aside, carefully pull out the Optics Unit upper end first.



Do not touch the lens of the Optics Unit.

5. Detach the CLM311 twisted pair cable (refer to number 15 in Figure 22) from the CLE321 board.
6. To detach the transmitter, loosen the transmitter ring by turning it to the right. If necessary, you can use the Allen key as a lever. Remove the transmitter from the Optics unit.
7. Detach the Laser Monitor Board CLM311 by loosening the two screws. You can access the screws through the hole in the transmitter ring (see number 5 in Figure 3 on page 20).
8. Write down the sensitivity value of the old, defective board, for example, 102 % . If no value is written on the CLM311, use the standard value 100 %.
9. Write down the sensitivity value of the new CLM311 board, for example, 98 % . If there is no value on the CLM311, use the standard value 100 %.
10. Attach the new CLM311 board into the Optics unit and tighten the two screws.
11. Place the transmitter to its place and tighten the transmitter ring in such a way that the labels of the transmitter face the measurement unit door.
12. Attach the CLM311 twisted pair cable to the CLE321 board.

13. Slide the Optics Unit to its place with the bottom end first. Make sure that no cables get stuck between the optics tube and other ceilometer components.
14. Snap the internal heater connector to its place.
15. Place all heater cables behind the holder and tighten the four holder screws.
16. Reconnect the battery, transmitter, receiver, and data cables to the CLE321 board.
17. Connect the power cable to connector J2 and the maintenance terminal to CL31.
18. Switch on the power with all three switches. Wait until the **Laser on** LED starts blinking at 2-second intervals. Ensure that all six diagnostic LEDs are lit. Refer to Figure 27 on page 119.
19. Open the command line with the **open** command. The password is **advanced**.
20. Enter the **get params factory** command and write down the **Target Outlaser** value.
21. The new calibration value is calculated as follows:

NEW OUTLASER = (OLD OUTLASER × NEW CLM311 SENSITIVITY VALUE) / (OLD CLM311 SENSITIVITY VALUE)

For example:

$880 \times 98 \% / 102 \% = 837$ (rounded to the nearest integer value)

22. Give the following command:

```
SET FACTORY OUTLASER <value>
```

where <value> is the new, calculated target outlaser value.

23. Give the **status** command and check from the status message that the measured outlaser is close ($\pm 5\%$) to the new outlaser value. Also check that the system status is OK and there are no suspect LRUs.

The ceilometer unit should now return to normal operation. Verify that the unit is working properly and that there are no other failures with the system. If other failures exist, separate troubleshooting may be necessary.

Replacing Modem Module DXL421 (Optional)



CAUTION!

Servicing the equipment must only be performed by qualified maintenance personnel.

Always replace the modem module indoors.

For detailed replacing instructions, see the spare parts instructions.

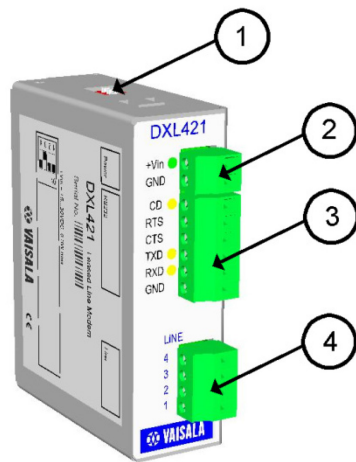

0410-169

Figure 33 DXL421 Leased Line Modem

- 1 = DIL switch
- 2 = Power input
- 3 = RS-232 interface
- 4 = Leased line interface

CHAPTER 9

TECHNICAL DATA

This chapter describes the technical specifications of CL31.

Mechanical Specifications

Table 25 CL31 Mechanical Specifications

Property	Description / Value
Dimensions:	
Measurement unit	620 x 235 x 200 mm (24 1/2 x 9 1/4 x 8 in.)
Height with shield	1190 mm (47 in.)
Total	1190 x 335 x 325 mm
Weight:	
Measurement unit	12 kg (26.5 lbs)
Shield and blower	19 kg (41.8 lbs)
Housing classification	IP66
Plywood transport container:	
Container size	1400 x 490 x 450 mm (55 x 19 1/4 x 17 3/4 in.)
Container weight	47 kg (103.6 lbs)

External Connector J1 - Window Blower

Table 26 Window Blower

Property	Description / Value
Connector J1	Type Binder series 693, 09-4228-00-07 (female)
Mating connector type	Type Binder series 693, 99-4225-70-07 7-pin (male) elbow

External Connector J2 - Power Input

Table 27 Power Input

Property	Description / Value
At nominal line voltage	100/115/230 VAC \pm 10%
Power consumption (typical):	
Total	310 W
Measurement unit	15 W
Internal heater	100 W
Window conditioner heater	175 W
Window blower	20 W
Frequency (min/max)	45-65 Hz
Power connector (J2)	Type Binder series 693, 09-4223-00-04 4-pin (male)
Mating connector type	Type Binder series 693, 99-4222-70-04 (female) elbow
No-break power supply	12 V Sealed Lead Acid Battery, 2 Ah
Oversvoltage protection	Low-pass filter , VDR

Output Interface

The data port can operate according to the following serial line standards:

- RS-232
- RS-485, multidrop, 2-wire
- DXL421 modem module
- LAN (Ethernet) interface option

LAN is available as a data output option and with the Air Quality Plug-and-Play package.

External Connector J3 - Data Line

The data line is intended to be used for measurement data communication, but it can also be used with a Ceilometer Maintenance Terminal, PC, or other terminals.

Table 28 Data Line

Property	Description / Value
Connector (J3)	Type Binder series 693, 09-4227-00-07 7-pin (male)
Mating connector type	Type Binder series 693, 99-4226-70-07 (female) elbow
Baud rate	19200 bps standard with RS-232 300, 1200, 2400, 4800, 9600, 19200, 38400, 57600, 115 200 bps available 300 or 1200 bps available with modem DXL421
Max. distance to operate	300 m (1000 ft) with RS-232, 1.2 km (4000 ft) with RS-485, all at 2400 bps with typical communication cables 10 km (6.2 mi.) with Modem
Standard character frame	1 Start Bit 8 Data Bits No Parity 1 Stop Bit
Standard character code	USASCII
Pin connections	1 RS-485 -/RTS# (no SW support) 2 RS-485+/RS-232 RxD/ Modem Lead A 3 Modem Lead B /RS-232 TxD 4 Ground 5 CTS# (no SW support) 6 +12 V DC (700 mA continuous, for local external equipment)

Modem circuits are non-polar and symmetrical. All modem circuits are electrically floating to overvoltage protection rating (300 V - 500 V).

Overvoltage protection in each circuit	Primary: Gas Discharge Tube Secondary: PCTs, Thyristor Overvoltage Protector
--	---



For information on data line connection options, see Figure 13 on page 37, and Figure 14 on page 38.

External Connector J4 - Maintenance Line

Maintenance line is intended for on-site maintenance and can be used with a Ceilometer Maintenance Terminal, PC, or other terminal.

Table 29 Maintenance Line

Property	Description / Value
Connector (J4)	Female five (5) pin M12 connector (for example, Lumberg RKF 5 / 0,5 M)
Mating connector type	Male five (5) pin M12 connector (for example, Lumberg RST 5-644)
Baud rate	9600 default and standard 300, 2400, 4800, 9600, 19200, 38400, 57600, 115 200 bps available
Distance to operate	300 m (1000 ft) at 2400 baud with typical communication cables
Standard character frame	1 Start Bit 8 Data Bits No Parity 1 Stop Bit
Standard character code	USASCII
Pin connections	See Figure 34 on page 138 (RTS/CTS not used).

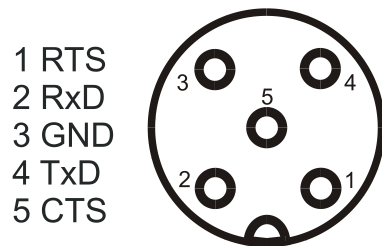

Figure 34 Pin Connections of Connector J4

Overvoltage protection in each circuit	Primary: Noble Gas Surge Arrester Secondary: VDRs, Transient Zener Diodes or normal Diodes
--	---

NPort 5232-T Serial Device Server Specifications

Table 30 NPort 5232-T Serial Device Server Specifications

Property	Value / Description
Speed	10/100 Mbps, auto MDI/MDIX
Network protocols	ICMP, IPv4, TCP, UDP, DHCP, BOOTP, Telnet, DNS, SNMP V1, HTTP, SMTP, SNTF
Supply voltage	+12 to 48 VDC
Current consumption	280 mA @ 12 V 150 mA @ 24 V
Altitude	Up to 2000 m
Max. operation distance	100 meters (110 yards)

Modem Module DXL421 Specifications

Table 31 Modem Module DXL421 Specifications

Property	Value / Description
Data rate	300, 1200 bps
Modem standards supported	V.21 300 / 300 bps FSK, V.22 1200 / 1200 DPSK and V.23 1200 / 1200 bps FSK
Supply voltage	+5 V to 30 VDC
Current consumption	0.09 W (Reset / power-down 9 mA, operation 26 mA)
Modem chip crystal frequency	11.0592 MHz
USART clock frequency	11.0592 MHz / 2 (Modem xtal freq. divided by 2)
Line interface	Matched to 600 Ω
Max. operation distance	10 km (approx. 6 miles)

Transmitter Specifications

Table 32 Transmitter Specifications

Property	Description / Value
Laser source	Indium Gallium Arsenide (InGaAs) Diode Laser
Center wavelength	910 ± 10 nm at 25 °C (77 °F)
Operating Mode	Pulsed
Nominal pulse properties at full range measurement:	
Energy	1.2 μWs ± 20 % (factory adjustment)
Peak power	11 W typical
Width, 50 %	110 ns typical
Repetition rate	10.0 kHz
Average power	12.0 mW
Max Irradiance	760 μW/cm ² measured with 7 mm aperture
Laser classification	Classified as Class 1M laser device in accordance with IEC/EN 60 825-1 Complies with 21 CFR 1040.10 and 1040.11 except for the deviations pursuant to the Laser Notice No. 50, dated July 26, 2001.
Beam divergence	±0.4 mrad x ±0.7 mrad

Receiver Specifications

Table 33 Receiver Specifications

Property	Description / Value
Detector	Silicon Avalanche Photodiode (APD)
Surface diameter	0.5 mm (0.02 in.)
Receiver bandwidth	3 MHz (-3db)
Interference filter	Center wavelength 915 nm typical
50 % pass band	36 nm
Transmissivity at 913 nm	80 % typical
Field-of-view divergence	± 0.83 mrad

Optical System Specifications

Table 34 Optical System Specifications

Property	Description / Value
Optics System Focal Length	300 mm (11.8 in.)
Effective lens diameter	96 mm (3.8 in.)
Lens transmittance	96 % typical
Window transmittance	97 % typical, clean

Performance Specifications

Table 35 Performance Specifications

Property	Description / Value
Measurement range	0 ... 7.6 km (0 ... 25 000 ft.)
Measurement resolution	10 m (33 ft) or 5 m (16 ft), selectable
Reporting resolution	5 m or 10 ft., units selectable
Reporting interval	2 ... 120 s, selectable
Measurement interval	2 s default (3 s in high-resolution mode)

Environmental Conditions Specifications

Table 36 Environmental Conditions Specifications

Property	Description / Value
Temperature range	-40 ... +60 °C (-55 ... +60 °C optional) -40...+140 °F (-67...+140 °F optional)
Humidity	0 ... 100 % RH
Wind	to 55 m/s (110 kt)
Vibration	Lloyds Register / IEC60068-2-6 5 - 13.2 Hz, ± 1.0 mm 13.2 - 100 Hz, ± 0.79 g

This page intentionally left blank.

APPENDIX A

INSTALLING BIRD DETERRENT

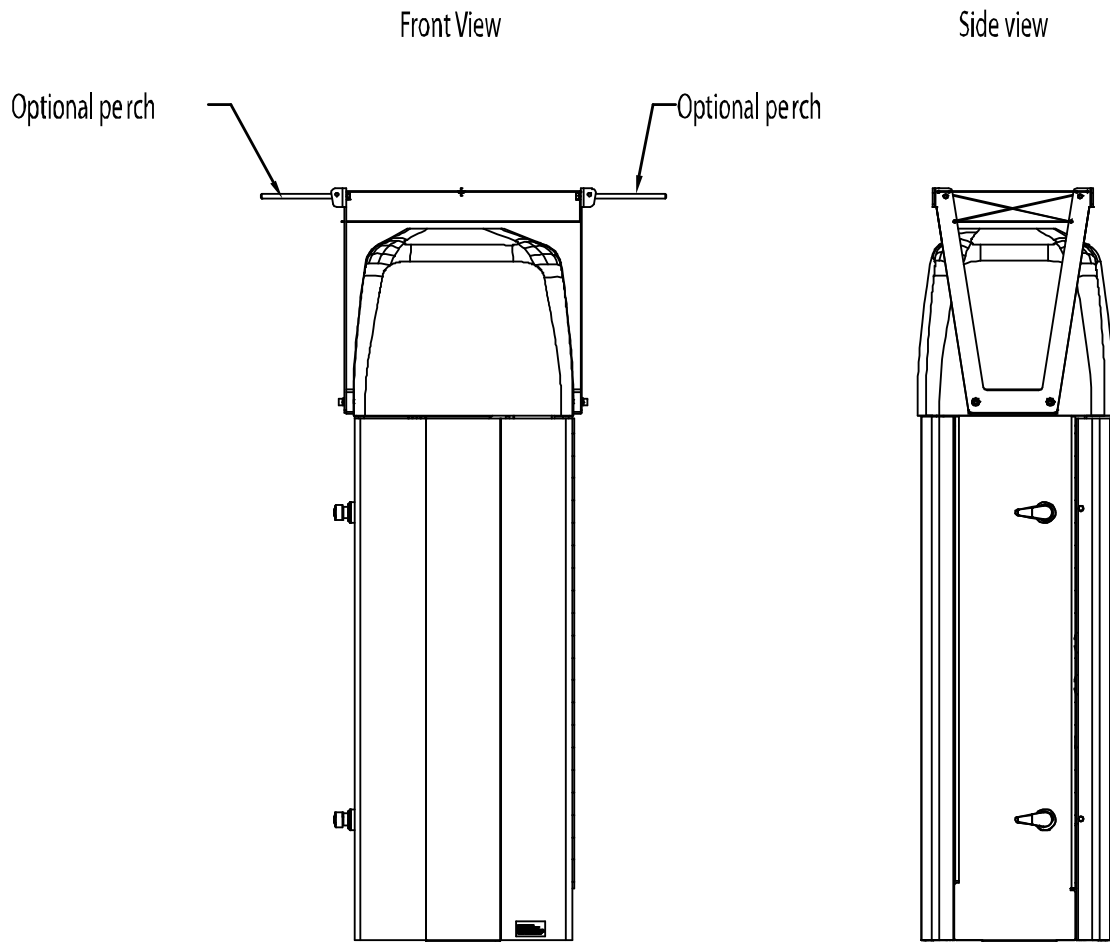

0910-116

Figure 35 CL31 Bird Deterrent Installation

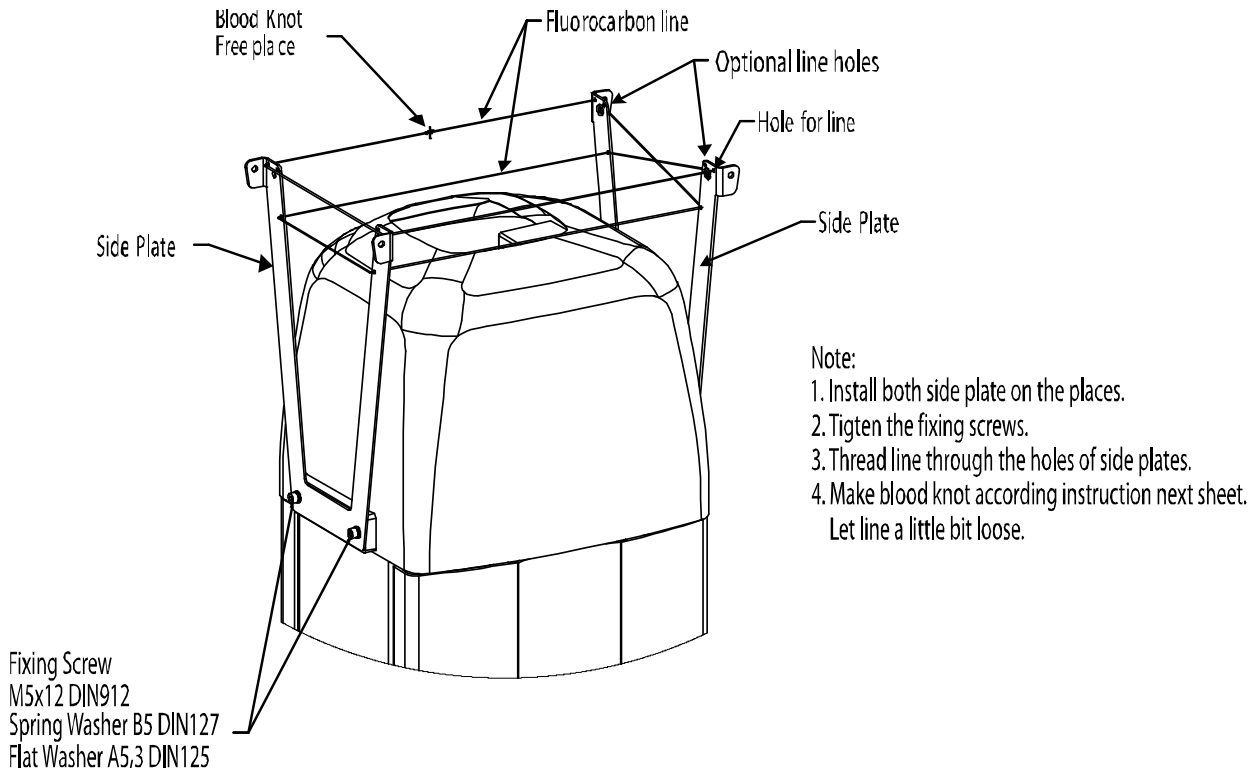
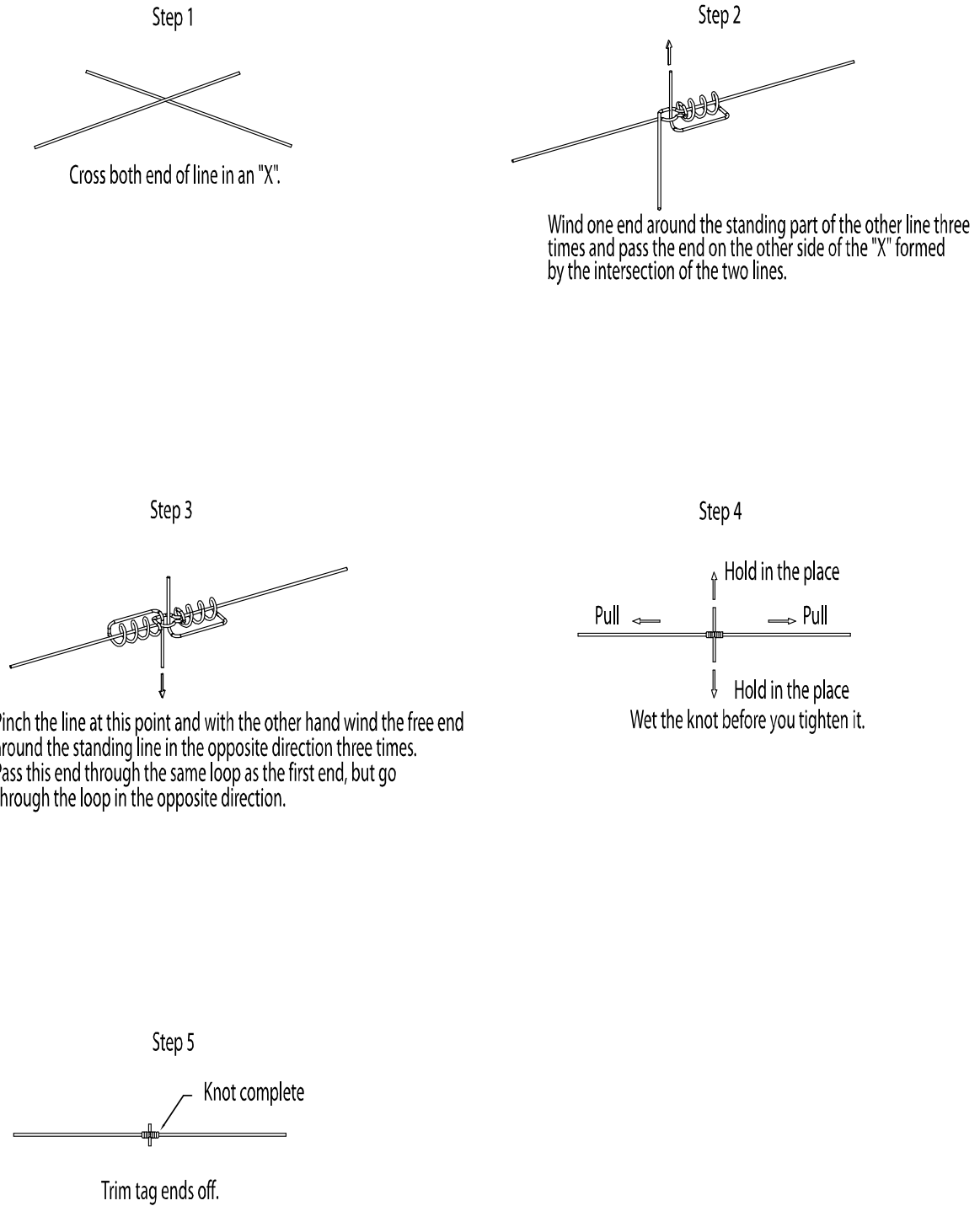

Figure 36 Bird Deterrent in Detail

0910-114



0910-117

Figure 37 Blood Knot Instructions

This page intentionally left blank.

APPENDIX B

CLEANING AND MAINTAINING PAINTED SURFACES

Vaisala recommends that you wash all the painted surfaces at least once a year. Use only warm water or warm, mildly soapy water. Wipe with soft cloth or sponge and rinse with clean water.



Do not use solvents or abrasive sponges when cleaning painted surfaces.

Preparing for Painting

To prepare the surface for painting:

1. Clean the surface and remove any loose coating with a scraper and a steel brush.
2. Use sandpaper on damaged areas and around the damaged area's edges.
3. Remove impurities, such as dirt and grease, with warm soapy water.
4. Rinse with warm water.

The surface must be completely dry before starting maintenance painting. Protect the surfaces that will not be painted with tape or paper.



Make sure the air temperature, the paint, and the painted surface are at least +10 °C and the relative humidity below 80% during painting and drying. Do not paint in rain or in direct sunlight.

Painting

After preparing the surface, coat the surface as soon as possible. Follow your paint manufacturer's instructions carefully.

1. Use a primer, such as Teknos INERTA PRIMER 5 epoxy paint 60-80 μm .
2. Paint the surface 2-3 times, so that the dry film layer thickness is 40-60 μm . Use, for example, Teknos TEKNODUR 0190 polyurethane 40 μm , so that the total thickness is 100-120 μm .

Commonly Used Vaisala Colors

- Solid White, Semi Gloss RAL 9003
- Shade Grey, Semi Gloss RAL 7035
- Construction Grey, Semi Gloss RAL 7024
- Signal Red, Semi Gloss RAL 3001

For more information on the paints, visit the paint manufacturer's website www.teknos.com.



If you use other paints, make sure the paint is compatible with the polyester powder coating.

APPENDIX C

DXL421 MODEM CONNECTION

The following figure provides information on the DXL421 modem connection.

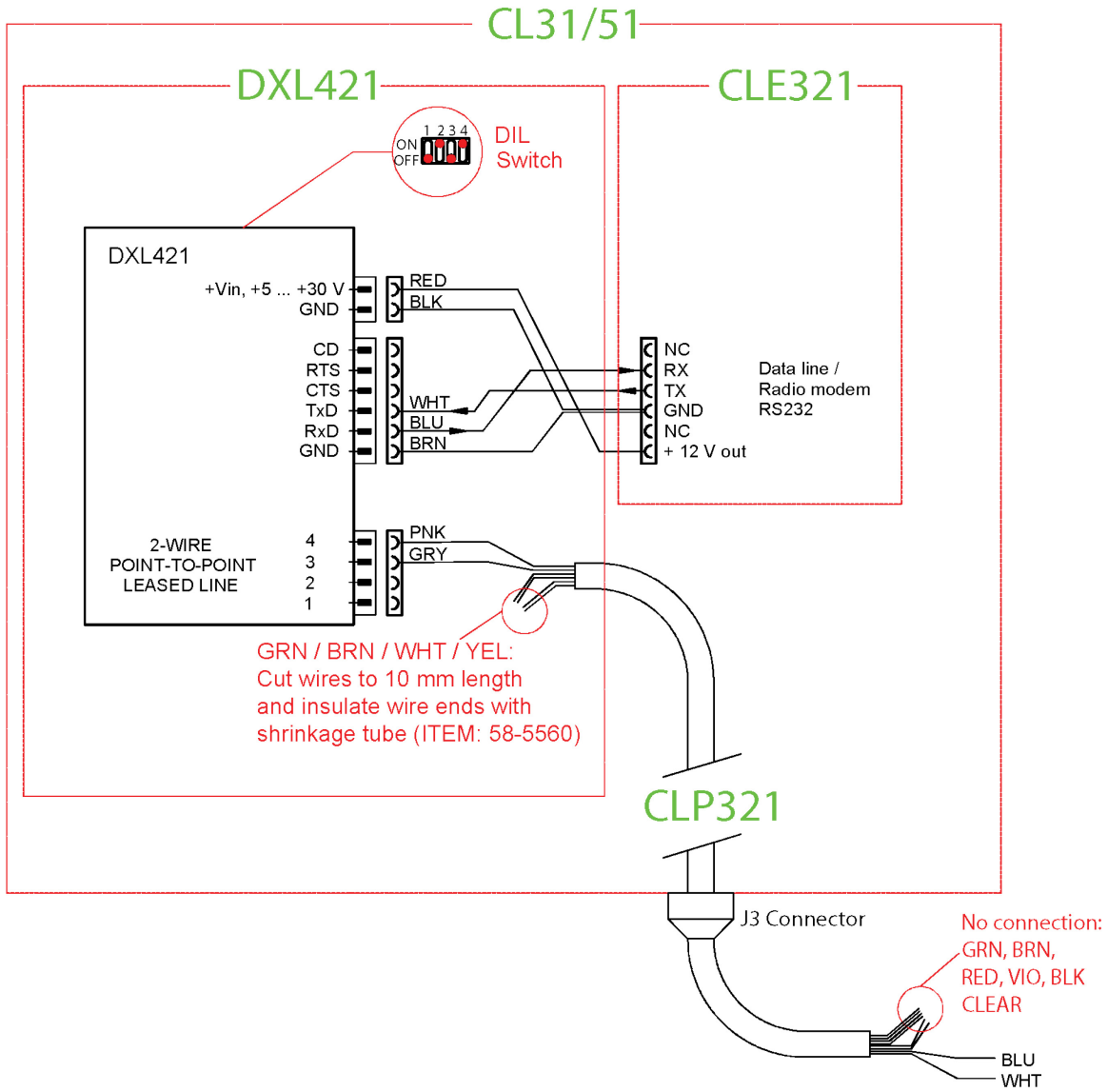

1510-030

Figure 38 DXL421 Modem Connection

Default Settings for the DXL421 Modem Connection

Bit rate	19200
Data bits	8
Stop bits	1
Parity	None
Handshake	None

INDEX

A

Air Quality Plug-and-Play package	17, 19, 42
Alarm check	97
Alarms	106
Laser failure	106
Laser temperature shut-off	106
Light path obstruction	106
Memory error	106
Receiver failure	106
Receiver saturation	106
Voltage failure	106
Atmospheric transmittance	51
Attaching the measurement unit	28
Average laser power	140

B

Background light	73
Backscatter	17
Backscatter coefficient	52
Beam divergence	140
Bird deterrent	19, 32, 109

C

Changing user-programmable parameter value	47
Character code	137
CLE321	40
CLOSE command	60
CL-VIEW	102
Connectors	35
Contrast threshold	53

D

Data messages	67
CL31 Status message	75
CT25K data message No. 1	83
CT25K data message No. 6	85
CT25KAM data message No. 60	86
CT25KAM data message No. 61	87
Detector	140
Digital display DD50	54
Door gasket check	99
DXL421	139, 149, 150

E

Electrostatic discharge	13
Environmental conditions	141
ESD	13
Ethernet	21
External connections	35
External connector J1	135
External connector J2	136
External connector J3	136
External connector J4	138
Extinction normalization	53

F

Focal length	140
Foundation screws	25

G

GET command	47
-------------	----

H

Hard target test	104
Height normalization	51

I

Internal humidity transmitter	19
Inversion	53

L

LAN	18, 21, 42
Laser	140
Laser classification	140
Letter case in commands	60
LIDAR	17
Lidar equation	51
Lidar ratio	52

M

Main parts	19
Maintenance	
Alarms and warnings	97
Battery check	99
Maintenance cable	19
Manual message	93
Max irradiance	140
Measurement parameters	73

Measurement range	141	MAINTENANCE	59
Measurement signal	49	OPEN	60
Meteorological Optical Range MOR	52	Service connection	102
Miscellaneous problems	107	SET command	47
MOR	52	Shock absorber	19
N		Sky condition	54, 85
No-break power supply	136	Activation	55
Noise cancellation	50	Option code	54
NPort 5232-T Serial Device Server	139	STATUS command	75
O		Storage	99
OPEN command	60	SUM	73
Operating principle	49	Switch settings for normal operation	41
Operation modes		T	
CONTINUOUS	59	TCP Client Mode	45
STANDBY	59	Technical support	108
Optical filter	140	Termination box	19
Optical system	140	Transmitter	140
Optical termination hood	19, 102	Troubleshooting	
Optional parts	19	Alarms	106
Output interface	136	Miscellaneous problems	107
Overvoltage protection	136, 137, 138	Warnings	105
P		U	
Painted Surfaces	147	UDP Mode	46
Painting	148	User commands	61
Parameters	47	User-Programmable Parameters	
Password	61	Factory Defaults	47
PC terminal cable	19	V	
Performance	141	Vertical visibility	53
Pin connections	138	Volume backscatter coefficient	51
Polling mode	94	W	
Polling string	94	Warning	
Polling string format	67	Ceilometer engine board failure	105
Principle of operation	49	Warning check	97
Pulse properties	140	Warnings	105
R		Battery failure	105
Real COM Mode	43	Blower failure	105
Receiver	140	Heater fault	105
Receiver CLR311		High background radiance	105
Specifications	140	Humidity sensor failure	105
Recycling	13	Laser monitor failure	106
Repetition rate	140	Receiver	106
Resolution	50, 141	Receiver optical cross-talk compensation	
Return signal strength	51	poor	105
RS-232	38	Relative humidity > 85 %	105
RS-485	37	Tilt angle > 45°	106
S		Transmitter expires	105
Safety	8	Window contaminated	105
SCALE	73	Warranty	15
Serial lines	59	Wavelength	140
CLOSED	60	Wedge bolts	25
DATA	59	Window cleaning	97

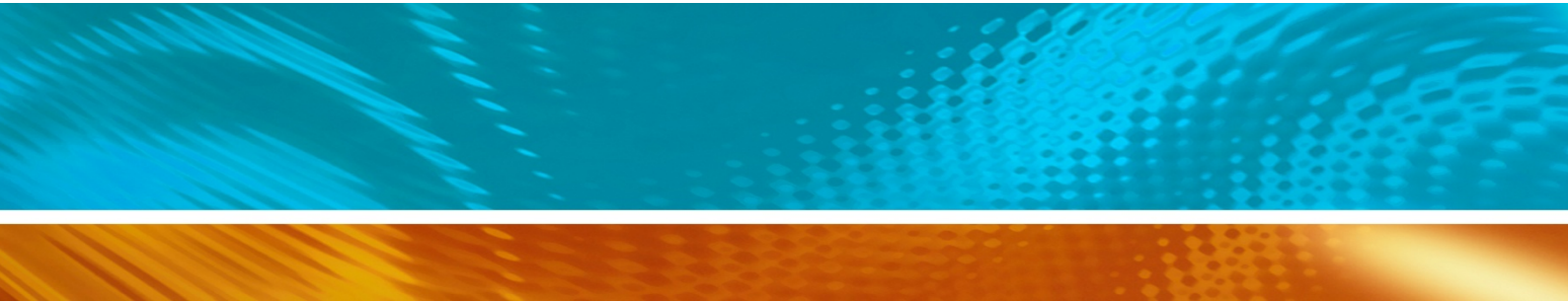

www.vaisala.com

